

Roberine



User Manual

Mower



F3 and R3

roberine.com

CE

Translation of the original manual Version V1.1

© Roberine 2019

● TYPE	DES. CODE		
SERIAL NUMBER			MANUF. YEAR
			REVS. RPM
			POWER kW
MASS	KG		
MAX. TOTAL MASS	KG		
MAX. LOAD FRONT AXLE	KG		
MAX. LOAD REAR AXLE	KG		
			
			
Goolkatenweg 65, 7521BE Enschede Netherlands			



NOTICE Keep the details on the type plate somewhere safe. If you have any questions about your machine or if you wish to order a component, the information on the type plate will help us to provide quick and effective assistance.



NOTICE Read this instruction manual carefully. Failure to do so may result in serious injury or damage to the machine. Keep this manual in a safe place. Always make sure the people who use the machine or carry out maintenance on it have read the manual and understand the instructions.

All rights reserved. No part of this publication may be reproduced, stored in a computerised data file and/or published in any way whatsoever, not electronically, mechanically, by photocopying or in any other way, without prior written permission from Roberine. This also applies to the accompanying drawings and diagrams.

Roberine reserves the right to alter components at any given time without giving the purchaser prior or immediate notification. The contents of this manual can also be updated without prior warning. Please contact your supplier's Technical Service for information on adjustment, maintenance or repair which is not covered in this manual. Or see the maintenance manual, which you have also received. This user manual has been produced with the greatest of care. Roberine cannot, however, be held liable for any errors in this publication or their consequences.

Table of contents

1 Preface.....	6
1.1 Who is this manual intended for?.....	6
1.2 Scope of this manual.....	6
1.3 Storing the manual.....	6
1.4 Manufacturer details.....	6
1.5 Guarantee and liability.....	7
1.6 Trademarks.....	7
1.7 Statutory standards and regulations.....	7
1.8 Recommissioning.....	7
1.9 Version history.....	7
2 Safety.....	8
2.1 Safety messages.....	8
2.2 Hazards.....	8
2.2.1 Mowing units.....	8
2.2.2 Protect children.....	8
2.2.3 Avoid roll over.....	9
2.2.4 Avoid pressurised liquids.....	9
2.2.5 Tyres.....	9
2.3 General safety instructions.....	10
2.4 Safety signs.....	11
2.5 Safety features.....	12
2.5.1 Safety mechanisms.....	12
2.5.2 Emergency stop.....	13
2.6 Instructions to the driver.....	13
2.7 Parking safely.....	13
2.8 Personal protective equipment.....	14
2.9 Environmental aspects.....	14
2.9.1 Disposal.....	14
2.9.2 REACH declaration.....	14
2.9.3 End of life disposal.....	14
3 Introduction.....	15
3.1 Mowing.....	15
3.2 Type plate of your machine.....	15
3.3 Engine.....	15
4 Description.....	16
4.1 Equipment.....	16
4.1.1 Description mower F3.....	16
4.1.2 Description mower R3.....	17
4.2 Engine compartment.....	17
4.3 Cabin.....	18
4.4 Seat.....	19
4.5 Driver's compartment.....	20
4.5.1 Command arm.....	21
5 Technical specifications.....	22
6 Commissioning.....	24
6.1 Before first use.....	24
6.1.1 Adjusting the seat.....	24
6.1.2 Adjusting the steering wheel.....	24

6.1.3 Use the correct type of fuel (diesel).....	25
6.2 Testing the safety system.....	26
6.2.1 The parking brake.....	26
6.2.2 Testing the mowing switch.....	27
6.2.3 Testing the parking brake (1).....	27
6.2.4 Testing the seat mechanism.....	27
6.2.5 Testing the drive pedal neutral position.....	28
6.2.6 Testing the parking brake (2).....	28
6.3 Daily checks before use.....	28
7 Operating.....	29
7.1 Starting the engine.....	29
7.1.1 Use of the hand throttle.....	29
7.1.2 Turning on the engine.....	29
7.1.3 Turning off the engine.....	30
7.2 Driving.....	30
7.2.1 Cruise control.....	30
7.3 Operating the mowing units.....	31
7.3.1 Before you start mowing.....	31
7.3.2 Lowering the mowing units.....	31
7.3.3 Raising the mowing units.....	32
7.3.4 Cross cut option.....	32
7.3.5 Adjusting the cutting height.....	32
7.4 Use of the weight transfer system.....	33
7.5 Operating the free-wheeling mechanism.....	34
7.6 After operating the machine.....	36
8 Maintenance.....	37
8.1 The bonnet.....	37
8.2 The hour meter.....	37
8.3 Maintenance intervals.....	37
8.3.1 After the first 5 hours.....	38
8.3.2 Daily maintenance.....	38
8.3.3 After the first 50 hours.....	38
8.3.4 Every 50 hours.....	39
8.3.5 Every 250 hours.....	39
8.3.6 Every 500 hours or once a year.....	39
8.3.7 Every 1,000 hours.....	40
8.3.8 Every 1,500 hours or every 2 years.....	40
8.3.9 Every 2,000 hours or every 2 years.....	40
8.3.10 Every 3,000 hours or every 3 years.....	40
8.4 Lubrication.....	40
8.4.1 Lubricants.....	40
8.4.2 Lubrication points.....	41
8.5 Engine oil.....	42
8.5.1 Checking the engine oil level.....	42
8.5.2 Changing the engine oil and filter.....	43
8.6 Cleaning the air intake grill and engine cooler.....	44
8.7 Checking the air resistance indicator.....	44
8.8 Cleaning the dust unloading valve.....	45
8.9 Cooling system.....	45
8.9.1 Checking the coolant level.....	45
8.10 Fuel filter and fuel/water separator.....	46
8.11 V-belt.....	48
8.12 Transmission and hydraulic oil.....	49
8.13 Cleaning the mowing units.....	49
8.14 Checking and replacing the flails.....	50
8.15 Maintaining the reels.....	51

8.15.1	Checking the mowing units.....	51
8.15.2	Adjusting the cutting knife to the bed knife.....	52
8.15.3	Adjusting the grass deflector and scraper.....	52
8.15.4	Back lapping the cutting knives.....	52
8.16	Maintaining the electrical system.....	55
8.16.1	Battery.....	55
8.16.1.1	Checking the battery.....	55
8.16.1.2	Replacing the battery.....	56
8.16.1.3	Cleaning the battery terminals.....	56
8.16.2	Replacing the light bulbs.....	56
8.16.3	Replacing fuses.....	59
8.16.4	Replacing relays.....	62
8.17	Checking the wheel bolts.....	64
8.18	Cleaning surfaces.....	64
8.19	Refuelling.....	65
9	Transport and storage.....	66
9.1	Transport.....	66
9.2	Preparing the machine for storage.....	67
9.3	Preparing the fuel and engine for storage.....	68
10	Recommissioning.....	69
10.1	Safety checks.....	69
10.2	Tyre checks.....	69
11	Troubleshooting.....	70
11.1	Safety problems.....	70
11.2	Engine problems.....	70
11.3	Electrical problems.....	73
11.4	Vehicle problems.....	74
11.5	Steering problems.....	74
11.6	Hydraulic problems.....	75
11.7	Driving problems.....	76
11.8	Mowing units problems.....	76
12	Warranty conditions.....	77
13	Appendices.....	78
13.1	Statement of Conformity.....	78
13.2	Dimensions.....	79

1 Preface

This is the user manual for the mower F3 and R3. This publication explains how the machine is assembled, what it is intended for and how to use it optimally.

This manual contains important information and instructions on safety, operation and maintenance. Please read all information and follow the instructions and guidelines in this manual carefully. This ensures long-term optimal performance and prevention of possible accidents and injuries.

Apart from this user manual, you also received other manuals concerning your Roberine mower. One manual is dedicated to the complete maintenance of your mower. The other manual belongs to the engine of your machine and provides you with all the information you need concerning the maintenance and repairs of the power source. Both manuals are mainly meant for service engineers.

1.1 Who is this manual intended for?

The user manual is intended for users and service engineers of the mower. Anyone who is not familiar with the operation or service of the mower is advised to fully read the following chapters and to follow the instructions exactly. Personnel that are familiar with the operation and service of the mower can use this manual for reference. The table of contents can be used to locate specific information.

1.2 Scope of this manual

This manual is a guide for the operation and service of the mower. Each operation and maintenance action is sequentially described in the relevant sections of this manual. Normal routine operation of the mower requires that operators and service engineers:

- Have sufficient technical knowledge and experience to carry out the assigned tasks.
- Are able to recognise and prevent hazards.
- Have read this manual and understand the contents.
- Have been adequately trained.
- Are able to follow the procedures in this manual.

1.3 Storing the manual

The user manual is part of your machine. Store the manual in the immediate vicinity of the machine. Always present a copy of the user manual for the mower to persons working with or on the machine. Make sure that everyone working with the machine has fully read and understood the content, and puts it into practice.

1.4 Manufacturer details

If you need any assistance, please contact your regional service centre. If you still have questions after reading this manual, we would encourage you to contact us. We appreciate all advice, feedback and suggestions from our customers. Please contact:

Manufacturer:	Roberine
Postal address:	PO Box 818 7500 AV Enschede The Netherlands
Visiting address:	Goolkatenweg 65 7521 BE Enschede The Netherlands
Telephone:	+31 (0)534 838383
Fax:	+31 (0)534 838333
E-Mail:	info@roberine.com
Internet:	www.roberine.com

1.5 Guarantee and liability

Please refer to the order confirmation and the delivery terms and conditions for the applicable guarantee and liability.

1.6 Trademarks

All trademarks stated in this manual are registered trademarks of Roberine or her suppliers.

1.7 Statutory standards and regulations

The instructions in this document take no account of the different national regulations and laws that must be obeyed when operating the mower. It is the sole responsibility of the purchaser to obey these regulations and laws.

1.8 Recommissioning

In the event of a recommissioning (e.g. relocation of the machine or a transfer of ownership), you **MUST** contact Roberine or representative subcontractor to discuss the procedures, terms and conditions, service contract, etc., so that the proper functioning and safety of the machine after recommissioning can be guaranteed. This manual should always be relocated with the mower.

If Roberine is not involved in a recommissioning, then Roberine is not liable for any claims of third parties arising from that recommissioning.

1.9 Version history

Every effort has been made to make this manual as accurate and complete as possible. Should you discover any errors or omissions, please bring this to the attention of your local Roberine service department or distributor, so that we can make amendments. This will enable us to improve our documentation.

The instructions in this manual do not take into account different national regulations and laws. When operating the mower, it is the sole responsibility of the user to make sure that all applicable local laws and regulations are obeyed.

During the lifetime of the mower, engineering improvements may result in the need to revise this manual. It is then at the discretion of Roberine, if a revision/new version of this manual is required.

The following table describes the main changes for each document version of this manual.

Version	Date	Changes
V1.0	May 2019	Initial version
V1.1	September 2019	Minor revisions

The information in this document concentrates solely on the use and maintenance of the mower as intended by Roberine. In the event that the products, parts or procedures are applied in any way other than described in this manual, then confirmation from Roberine must be obtained as to the correctness and suitability of that use.

2 Safety

The mowers F3 and R3 have been carefully designed and expertly built for safe which is confirmed by the EG declaration. However, there will always be dangers and safety risks that cannot be excluded. These risks are inherent to operators and service engineers using the machine.

This chapter is devoted to safety instructions and precautions, how they are indicated and the conditions the driver must comply with. It is very important that you carefully read and understand the safety instructions and precautions and will take them into account during all circumstances!

2.1 Safety messages

This manual contains various pictograms to show which dangers or risks may occur. Your machine is also provided with several pictograms, see *Safety signs* on page 11. Below you will find an overview of the pictograms used in this manual, what they mean, what they refer to or what they warn you for.



Warning

Indicates a situation which may lead to physical injury and/or material damage if one does not obey the safety instructions.



Caution

Warns of a situation that may cause material damage if one does not follow the safety instructions.



Information

Provides additional information that is helpful to accomplish a task or to avoid problems.

2.2 Hazards

2.2.1 Mowing units

WARNING Avoid injury resulting from contact with the mowing units:

- Rotating mowing blades can cut off arms and legs or throw objects into the air.
- Keep hands, feet and clothes away from the mowing units and rotating parts when the engine is running.
- Always remain alert and carefully drive forwards. People and, in particular, children can enter the area to be mowed before you realise it.
- Before driving in reverse, turn off the mowing units and look to see whether anybody is behind or next to the machine, particularly children.
- Do not mow while driving in reverse.
- Stop the mowing blades when you are not mowing.
- Always park the machine safely before leaving the driver's seat.
- Keep all body parts away from the edges of the mowing blades. If the locking mechanism is released, the mowing blades may start to rotate as a result of any residual hydraulic pressure or any other energy stored in the system.
- Keep bystanders away from the mowing units when adjusting them or performing maintenance work on them.
- Always wear gloves when rotating the mowing blades by hand.
- If one of the mowing blades is rotated by hand other cylinders may also start rotating.



2.2.2 Protect children

WARNING Children find mowers and mowing interesting and fun. They do not understand the risks of rotating blades and do not realise that the user is not aware of their presence.



- Never give children a ride on the machine or an add-on component, even if the blades are turned off. Serious injury or even death may be the result if young children think that they are allowed to play with the machine.

- Children who were given a ride on the machine in the past may suddenly appear in the mowing area for another ride and be knocked down or run over by the machine.
- A child may be involved in a serious accident if the driver does not pay attention to the possible presence of children, particularly if a child approaches the machine from the rear. Before and while driving in reverse, turn off the mowing blades and look to see whether anybody is behind or next to the machine.
- Never use the machine as a recreational vehicle or to amuse children.
- Always be aware of the presence of children. Never assume that children remain in the place where you last saw them. Stop the machine if a child enters the work area.

2.2.3 Avoid roll over

WARNING Inclines play an important role in accidents where the driver loses control of the machine and/or the machine tips over, often with serious or fatal consequences. It is necessary to take extra care when working on inclines:



- Do not mow on an incline if you feel unsafe.
- Drive straight up and down inclines, not crossways.
- Never use the machine on an incline steeper than 32 %.
- Look out for holes, uneven surfaces, rocks, stones, or other hidden obstacles. The machine could tip over on uneven terrain. Objects can be hidden from view by high grass.
- It is not recommended to drive the machine on an incline with wet grass. The wheels may lose their grip even if the brakes work properly.
- Preferably do not start, stop or turn the machine on an incline. If the tyres lose their grip, turn off the mowing cylinders and slowly drive straight down the incline.
- Make sure that all movements on an incline are performed slowly and carefully. Do not suddenly change speed or direction.
- Do not mow close to steep inclines, ditches, embankments, dykes or water. The machine could suddenly tip over if one of the wheels protrudes over the edge or if an edge collapses. Maintain a safe distance between the machine and any dangers.
- Always drive the machine very slowly and avoid stopping suddenly if the mowing units have been removed.
- Lower the mowing units when driving on slopes or inclines, because this increases stability.

2.2.4 Avoid pressurised liquids

WARNING Pressurised liquids can cause serious personal injuries.



- Depressurise the hydraulic systems when you do maintenance on your machine or ask your Roberine dealer to relieve the pressure before you disconnect hydraulic lines or other lines.
- Make sure that all hydraulic fluids connections are tightened before you pressurise the system.
- Regularly check the hydraulic fluids connections. They can loosen as a result of damage or vibrations. Tighten loose connections.
- Regularly check the hydraulic hoses and lines. Hydraulic hoses can become faulty as a result of damage, kinks, ageing and exposure to the elements. Replace any damaged hoses and lines.



CAUTION! In the event of an accident, immediately contact a medical specialist. If the fluid penetrates the skin, it must be removed within a couple of hours by means of an operation in order to prevent gangrene. Medical specialists who are not familiar with this type of injury are requested to consult reliable medical sources.

2.2.5 Tyres

WARNING Tyres or rims that unexpectedly spring loose can cause serious injury or even death.



- Do not fit tyres if you do not have the correct equipment or sufficient experience.
- Always ensure the tyres have the correct tyre pressure. Do not inflate the tyres to more than the recommended pressure.
- Never perform welding work on or heat a wheel while a tyre is still fitted. The heat can cause the pressure to increase and cause the tyre to explode. Welding can weaken the structure or deform the wheel.
- When inflating the tyres, use a clamping valve with an extension hose that is long enough to allow you to stand to the side of the tyre so that you do not have to stand in front of or hang over the tyre.
- Regularly check the tyres for cuts and bulges, damaged rims and missing nuts or bolts.

2.3 General safety instructions

WARNING



- Do not run the engine in a confined space, where hazardous carbon monoxide vapours can collect.
- Do not leave the machine unattended while the engine is running.
- Never raise the mowing platforms while the blades are rotating.
- Never use the machine if a protective cover is faulty or if the safety devices are not in place.
- Do not change the settings of the speed controller and do not tune the engine to increase its power. Running the engine at a speed too high for the engine, increases the risk of personal injury.
- Turn off the engine and remove the ignition key before:
 - > checking, cleaning or working on the machine;
 - > refuelling;
 - > changing the height setting of the mowing units; and
 - > removing a blockage or foreign object. Always inspect the machine for damage and make any repairs before you restart and use the machine again.
- Do not use the machine when under the influence of alcohol, drugs or medicines that can impair your driving abilities.
- Do not wear (in-ear) headphones to listen to music. Safe operation and maintenance of the machine requires your full attention.

CAUTION!



- Only mow in daylight or with good artificial lighting.
- Remember that there is no such thing as a safe incline. Pay close attention, particularly when driving on grass inclines. To avoid roll-over:
 - > Do not suddenly stop or start driving when facing uphill or downhill.
 - > Drive slowly on inclines.
 - > Always pay attention to uneven surfaces, holes and other hidden dangers.
 - > Never mow crossways on an incline.
- Drive slowly around sharp corners. Be careful when approaching blind corners, bushes, trees and other objects that can impede vision.
- Pay attention to traffic when crossing or working close to public roads.
- Stop the mowing blades before driving over a terrain that is not covered by grass.
- Never aim the ejected material at bystanders and do not allow people to get close to the machine while it is in use. Stop the machine if somebody enters the work area.
- Only use accessories and add-on units that have been approved by the manufacturer.
- Do not transport passengers:
 - > Only the driver is allowed to sit on the machine. Passengers on the machine or the add-on units may be hit by flying objects or be thrown off the machine, which may result in serious injury.
 - > Passengers can impede the driver's view and make the machine unsafe to use.

2.4 Safety signs

The following safety signs are located on the machine.

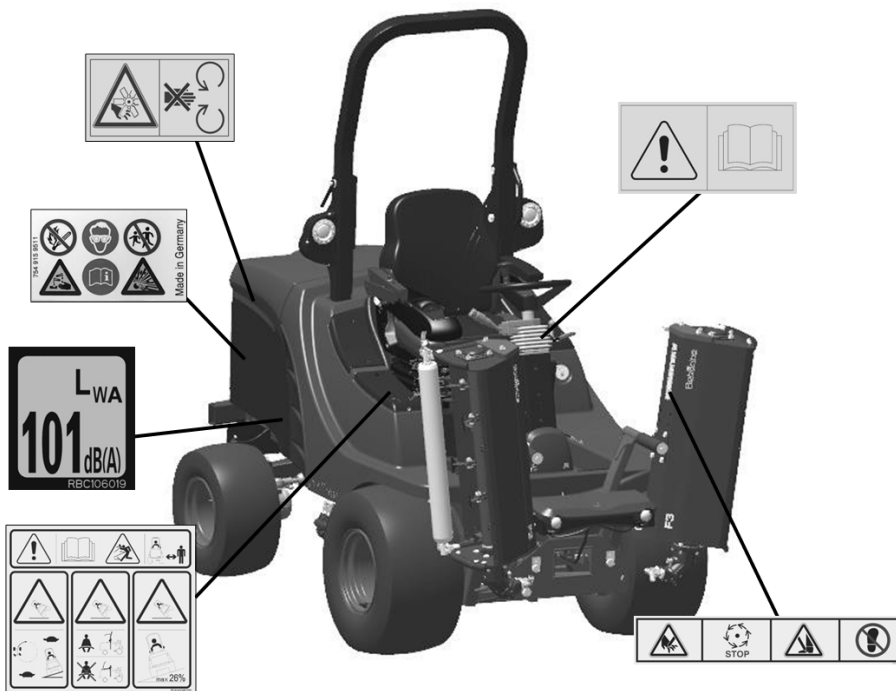

CAUTION!

This user manual contains important information necessary for safe machine operation. Observe all safety rules to avoid accidents.



CAUTION!

Avoid injury from rotating blades. Keep hands and feet away from rotating blades. Turn off the engine before servicing, lubricating or removing cutting units. Remember that the machine can keep moving after the engine has been turned off. Wait until everything has come to a complete stop.



CAUTION!

Avoid injury from fan. Do not open or remove safety shields while engine is running.



CAUTION!

- Read the user manual before using the machine.
- Risk of flying objects. Keep away from the machine when it is in operation.
- Risk of tipping over: take corners slowly and drive slowly on inclines.
- Always wear the seat belt when the ROPS is up. Do NOT wear the seat belt when the ROPS is folded down.
- Do not use the machine on an incline steeper than 32%. Always use the ROPS when driving on an incline.



CAUTION!

- Do not smoke and keep fire away from battery.
- Wear eye protection and gloves when carrying out maintenance on the battery.
- Keep children away from the battery when carrying out maintenance on the battery.
- Do not spill electrolyte on skin.
- Read the user manual before carrying out maintenance on battery.
- Batteries produce a flammable and explosive gas.



This label on your machine indicates that this model complies with the applicable requirements of the 2000/14/EC Noise Emission in the Environment Directive.

2.5 Safety features

2.5.1 Safety mechanisms

Seat belt



- Always use a seat belt when you operate the machine to minimise the chance of injury from an accident, such as an overturn.
- Never modify, disassemble or attempt to repair the seat belt.
- Replace entire seat belt if mounting hardware, buckle, belt, or retractor show signs of damage.
- Inspect seat belt and mounting hardware at least once a year. Look for signs of loose hardware or belt damage, such as cuts, fraying, extreme or unusual wear, discolouration or abrasion. Replace only with replacement parts approved by Roberine
- Layers of heavy clothing can interfere with proper positioning of the seat belt and can reduce the effectiveness of the seat belt.

Roll-over Protection Structure



CAUTION! Keep the ROPS installed properly.

- Never operate the machine without the ROPS installed.
- Make sure all parts of the ROPS are installed correctly if the ROPS structure is loosened or removed for any reason. All ROPS hardware should be tightened to the proper torque as per manufacturer's recommendations.
- Any changes to the ROPS must be approved by the manufacturer. The protection provided by the ROPS will be impaired if the ROPS is subjected to structural damage, is involved in an overturn incident, or is in any way altered by welding, bending, drilling, or cutting.
- The seat is part of the ROPS safety zone. Replace only with a seat approved by Roberine.
- Never attempt to repair a damaged or altered ROPS. It must be replaced to maintain the manufacturer's certification of the structure.

2.5.2 Emergency stop



CAUTION! Always stay seated and hold the steering wheel when you need to make an emergency stop. Leaving the seat or releasing the steering wheel may cause dangerous situations.

In case of emergencies:

1. Quickly remove your foot from the foot pedal.
The hydraulic brake will be activated.
2. If necessary, slowly pull the parking break until the machine slows down.

2.6 Instructions to the driver

The driver is responsible for working safely with the mower. When the driver does not follow the safety rules and instructions, it can cause serious personal injury and damage to the machine.

The driver:

- has been trained and is qualified to operate the machine.
- is attentive to and avoids dangerous situations.
- always inspects the machine before use.
- tests the functioning of the machine.
- inspects the working environment.
- keeps bystanders at a safe distance.
- only uses the machine for which it is intended.
- wears the correct safety equipment and clothes.
- does not operate the machine when under the influence of medicines, alcohol or drugs.
- fully read and understood the safety and operating instructions.
- is familiar with local legislations and rules.

2.7 Parking safely

Always park the machine safely before carrying out maintenance tasks or storage.

1. Park the machine on a horizontal surface and not on an incline.
2. Turn off the mowing units.

3. Lower the mowing units to the ground.
4. Apply and lock the parking break
5. Turn off the engine.
6. Remove the ignition key.
7. Wait until the engine and all the moving parts have come to a standstill before leaving the driver's seat.
8. Close the fuel tap if the machine has one.
9. Disconnect the battery's negative cable before carrying out any maintenance work on the machine.

2.8 Personal protective equipment

It is important to follow the safety instruction to prevent damage or personal injury.

- Always wear safety glasses with side protection when operating the machine.
- Wear close-fitting clothing and use personal protective equipment that is suitable for the work.
- When mowing, always wear sturdy shoes and long trousers. Do not operate the machine in bare feet or when wearing open sandals.
- Use the necessary personal protective equipment, such as earplugs. Loud noises can cause a loss of hearing or deafness.

2.9 Environmental aspects

2.9.1 Disposal

The owner and/or user of the mower is responsible for the disposal of waste materials (oil etc.) in accordance with the applicable local laws or regulations. When the machine has reached the end of its useful life, the owner and/or user is responsible for the safe disassembly of the machine and for the disposal of the components, in accordance with the local laws or regulations.

2.9.2 REACH declaration

The REACH regulation became effective on 1st June 2007. The aim of the REACH regulation is to ensure a high level of protection of human health and the environment from chemical substances.

Roberine manufactures articles in compliance with current revision of the REACH regulation, and is downstream-user of chemical substances.

Roberine has the intention to fully comply to REACH regulation and has checked its suppliers to make sure they comply with REACH requirements for all materials and substances used in our products.

Roberine will provide relevant information e.g. Material Safety Data Sheet (MSDS) on request.

2.9.3 End of life disposal

When the mower has finally reached the end of its useful life, the owner and/or user is responsible for the safe disassembly of the mower and for the disposal of its components and parts in accordance with the local laws, regulations and recommendations.

3 Introduction

3.1 Mowing

The Roberine F3 and R3 have been specially designed to mow grass on sports grounds, parks and green public areas. The flail mower unit of the F3 has been developed in collaboration with Votex. Votex is especially known for its verge and ditch-side flail mowers. The specially designed cutting head in combination with the unique Votex flails enable a relatively high cutting speed to be realised even when the grass is high. This ensures a smooth mowing result. Furthermore, the cuttings spread out evenly, creating a smooth mowing result. The easily adjustable cutting height makes the machine extremely versatile and guarantees a perfect mowing result even on uneven surfaces.



CAUTION! Only use the mower for purposes for which it is developed and intended. Any other, improper, use without written consent from Roberine, will invalidate the guarantee!

3.2 Type plate of your machine

The machine's type plate indicates that this model satisfies the applicable safety requirements of Machinery Directive 2006/42/EC and EMC 2004/108/EC.

● TYPE	DES. CODE		
SERIAL NUMBER			
MASS	KG		
MAX. TOTAL MASS	KG		
MAX. LOAD FRONT AXLE	KG		
MAX. LOAD REAR AXLE	KG		
		MANUF. YEAR	
		REVS. RPM	
		POWER kW	
		CE	
		Roberine	
		Goolkatenweg 65, 7521BE Enschede Netherlands	

The type plate is located on the battery frame of the mower.



NOTICE Keep the information of your type plate in a safe and secure place. When you have questions about your mower F3 or R3 or need to order replacements parts, this information will enable us to provide efficient and adequate service.

3.3 Engine

The engine used for the drive unit of the mower and for the pump for the oil supply for the hydraulic functions is the Yanmar 3TNV84T-BKVX



NOTICE All the properties of the engine and information about its use, maintenance and repairs can be found in the engine's manual. You have received this manual from us.

4 Description

Your machine is the mower F3 or R3. Both models can be provided with either an ROPS or a cabin.

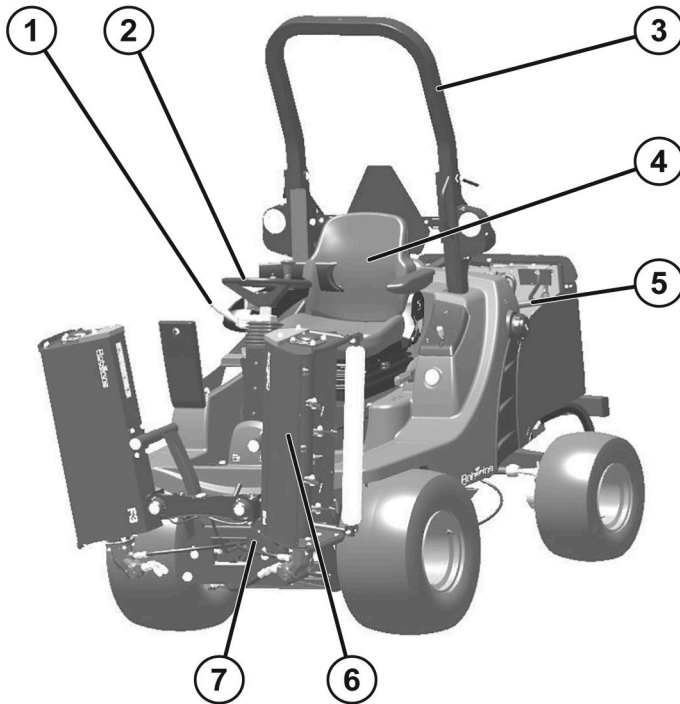

1. Command arm: This is where all the operating buttons and the display are located.
2. Steering wheel.
3. ROPS. The Roll Over Safety Structure prevents entrapment should the machine roll over.
4. Seat.
5. Engine. The engine powers the mower
6. Mowing units. These are either flail units (F3) or reel units (R3)
7. Locking lever

4.1 Equipment

4.1.1 Description mower F3

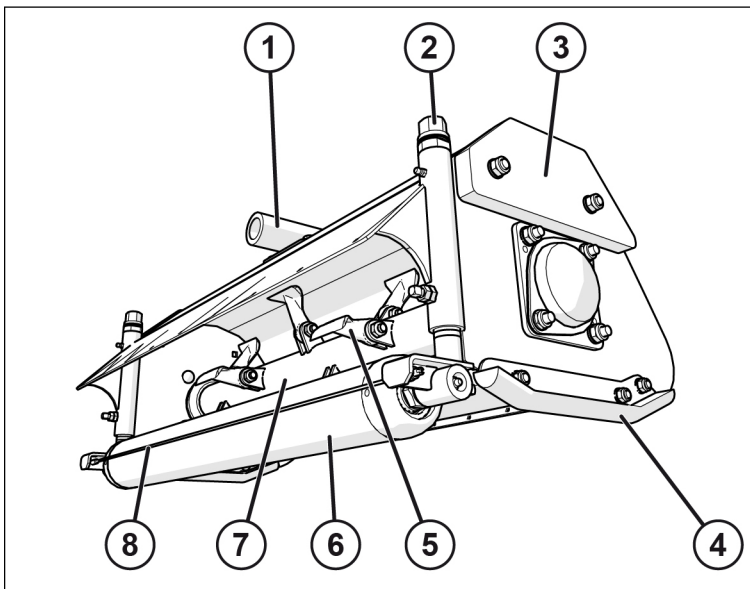

1. Pivot
2. Cutting height adjuster
3. Counter weight
4. Slide shoe
5. Flail
6. Roller
7. Rotor shaft
8. Scraper

4.1.2 Description mower R3

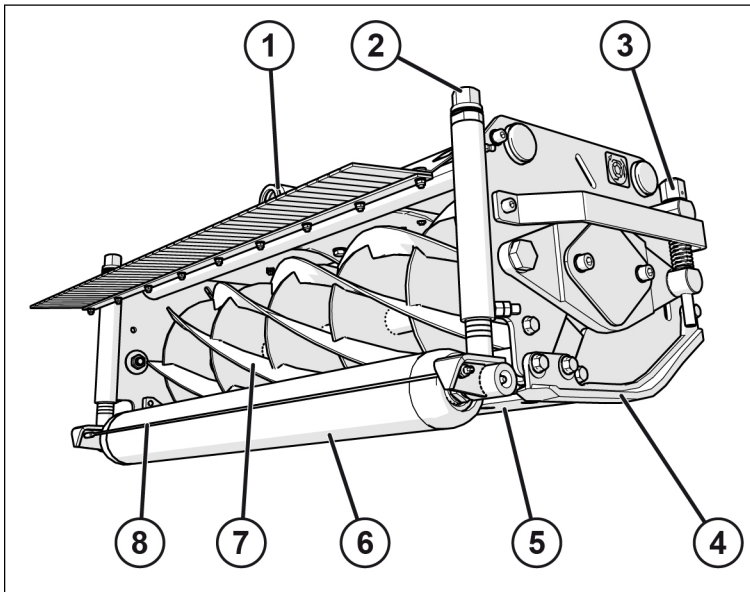

1. Pivot
2. Cutting height adjuster
3. Adjuster
4. Slide shoe
5. Bed knife
6. Roller
7. Mower reel
8. Scraper

4.2 Engine compartment

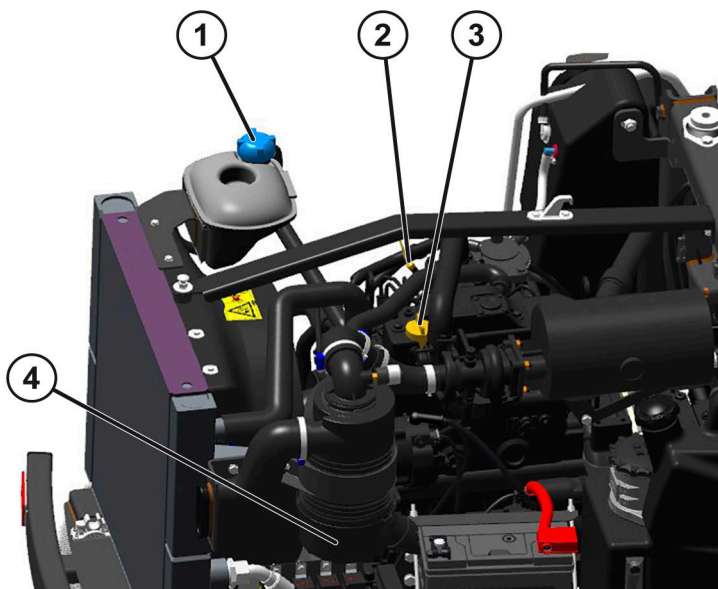

1. Cooling fluid filling cap
2. Oil dipstick
3. Oil filling cap
4. Air cleaner cap

4.3 Cabin

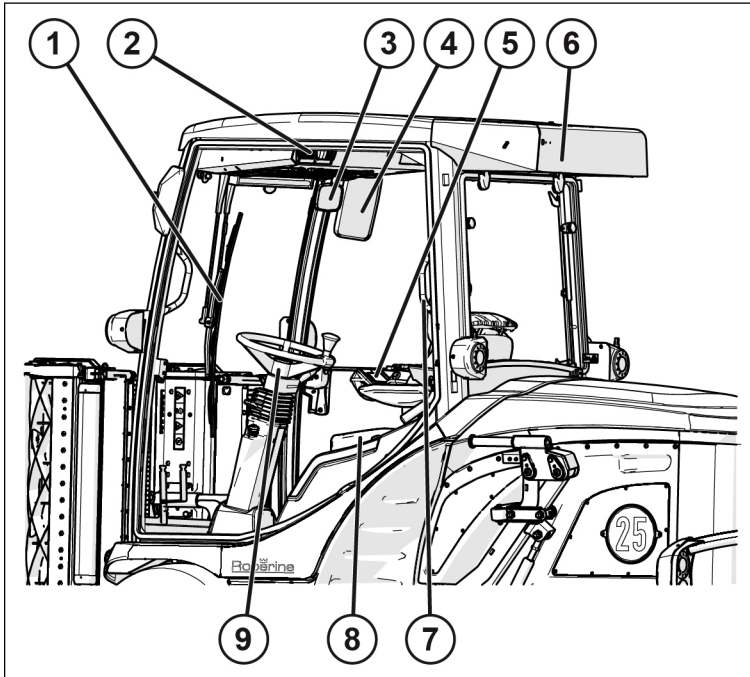

1. Windscreen wiper
2. Dashboard
3. Rear view mirror
4. Side mirror
5. Command arm
6. AC Cooler
7. Handle
8. Seat
9. Steering wheel

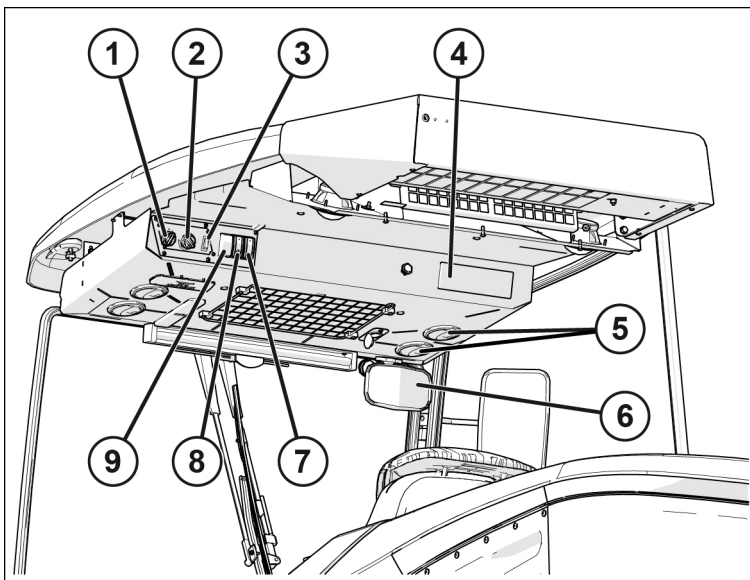

1. Step switch for radial blower speed
2. Controller for temperature (Thermostat)
3. Switch for air conditioner
4. Radio
5. Air vents
6. Rear view mirror
7. Beacon light switch
8. Windscreen wiper fluid
9. Windscreen wiper switch

4.4 Seat



1. Armrest adjuster
2. Back rest adjuster
3. Seat position adjuster
4. Seat height adjuster
5. Horizontal shock absorber
6. Lumbar support adjuster

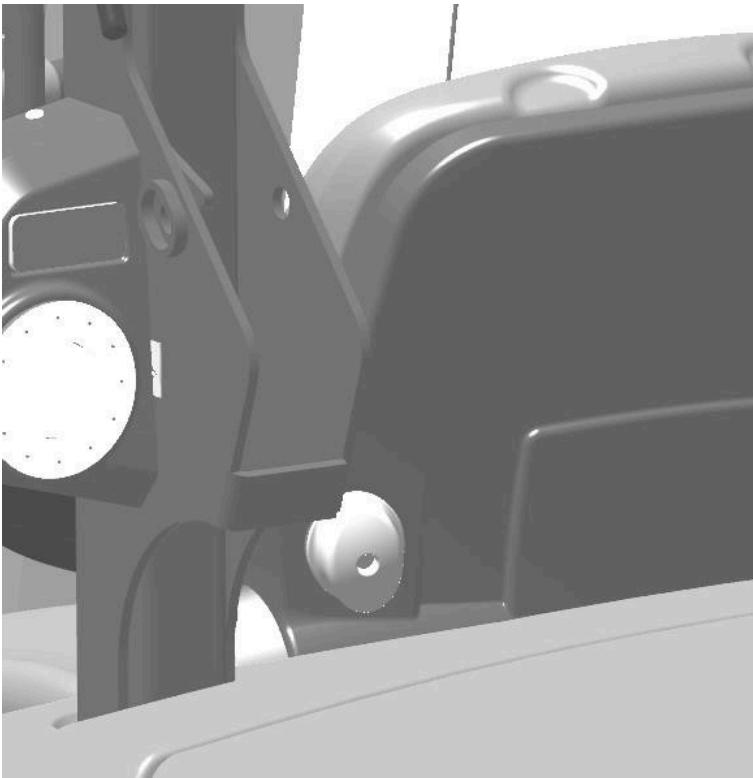

4.5 Driver's compartment



1. Steering wheel adjuster
2. Ignition
3. Hour meter
4. Steering wheel
5. Foot pedal
6. Command arm



1. Battery charge indicator
2. Low engine oil pressure indicator
3. Coolant temperature indicator
4. Preheat system indicator
5. Cruise control indicator
6. Indicator left and right
7. Hydraulic oil temperature indicator
8. Fuel indicator

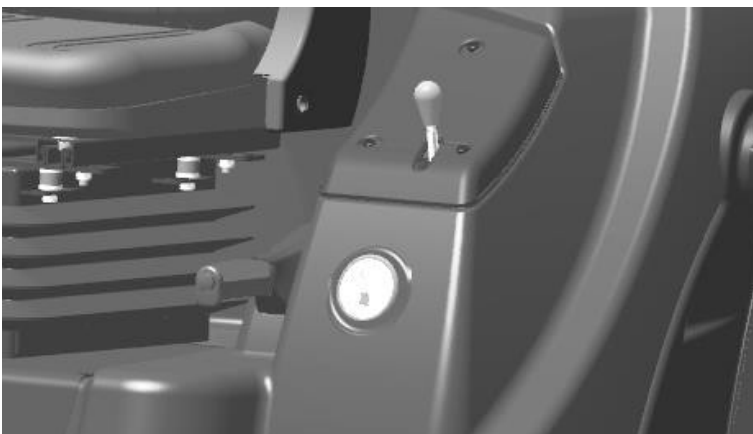

1. Parking brake
2. Hand throttle
3. Fuel gauge

4.5.1 Command arm



1. Mowing/back lapping switch
2. Indicator left and right
3. Raising/lowering activation switch.
4. Cruise control.
5. Weight transfer
6. Raising/lowering right-hand mowing unit.
7. Raising/lowering middle mowing units.
8. Raising/lowering left-hand mowing unit.
9. Cross-cut button: activates the raising/ lowering function of all mowing units at the same time.

5 Technical specifications

Engine specifications	
Make	Yanmar Engine
Model number	3TNV84T-BKVX
Power	30.2 kW / 41 hp
Type	Vertical, in-line, four-stroke, water-cooled diesel engine
Cylinders	3
Bore	84 mm (3.15 inch)
Stroke	90 mm (91.29 cu inch)
Cylinder volume	1,496 cc
Speed, high	2,700 rpm
Speed, low idling	1,150 rpm
Cooling type	Coolant
Oil filter	Replaceable element, see the Roberine spare parts manual.
Air filter	Cyclone filter and air filter
Maximum driving speed	25 km/h (15.6 mph)
Maximum mowing speed	13 km/h (8.1 mph)
Electrical system	
Loading system	55A V-Belt driven alternator
Starter motor	Solenoid connection
Battery voltage	12 Volt
Battery Ampere	45 Ah
Volume	
Fuel tank	45 litre
Hydraulic oil	55 litre
Cooling system	7.2 litre
Engine oil	4.8 litre
Recommended lubricants	
Hydraulic oil	Shell Tellus S3 68
Biodegradable hydraulic oil	Panolin HLP Synth 46
Engine oil	Shell Rimula R4 L 15W40 (API CF)
Grease	Shell Gadus S2 V220
Copper Grease	Kroon Copper + plus

Tyres	
Front	320/55-12 (26x12 -12 8 Ply)
Rear	250/50-10 (20x10-10 6 Ply)
Front pressure	1.2 bar 120 kPa (17.4 psi)
Rear pressure	1.0 bar 100 kPa (14.5 psi)

Dimensions	
Total height of standard machine	170.5 cm
Total height with ROPS	233.7 cm
Total length with mowing units	280 cm
Total width ET-0/ET-25	135/140 cm
Kerb weight with mowing units and ROPS	1,225 kg
Dry weight	896 kg

Mowing units F3	
Number of units	3
Type	Flail
Diameter	25 cm
Number of flails	12
Total mowing width	215 cm
Flail rotational speed	3,500 rpm

Mowing units R3	
Number of units	3
Type	Reel/cylinder
Diameter	25 cm
Number of blades/knives	6 or 8
Total mowing width	215 cm
Cylinder rotational speed	950 rpm

Sound level measurement	
Average sound pressure (open seat)	Lwa 101 dB(A)
Operator ear	79 +/- 1 dB(A)
Average sound pressure (closed cabin)	Lwa 101 dB(A)
Operator ear	79 +/- 1 dB(A)

6 Commissioning

Your mower has been assembled and adjusted with great care.

6.1 Before first use

Before you start using your mower, make sure that:

- there are no transport damages;
- there are no oil leakages;
- the spare parts of your machine are present;
- the engine oil level is correct;
- the hydraulic oil level is correct;
- the coolant level is correct; and
- the cutting height is correct, see *Adjusting the cutting height* on page 32.

Then:

- Adjust the seat.
- Adjust the steering wheel.
- Add the right type of fuel.

6.1.1 Adjusting the seat



CAUTION! Never adjust the seat while the machine is moving. Bring the machine to a standstill before adjusting the seat so as to avoid losing control of the machine.



NOTICE Refer to *Seat* on page 19 for references.

Adjusting the height and weight setting

- Pull the seat height adjuster (4) upwards to raise the seat.

The seat adjusts automatically to the driver's weight.

- Push the seat height adjuster (4) downwards to lower the seat.

Adjusting the damping

- Push the horizontal shock absorber adjuster (5) backwards to activate horizontal damping to dampen vibrations in the driving direction.
- Push the horizontal shock absorber adjuster (5) forwards to block horizontal seat movement.

Adjusting the backrest

- Move the back rest adjuster (2) up or down to place it in the desired position.

Forwards/backwards adjustment

Pull the seat position adjuster (3) upwards and slide the seat forwards or backwards to the desired position. Release the adjuster to lock the seat in position.

Adjusting the armrest

Rotate the armrest adjuster (1) to adjust the angle of the armrest.

Adjusting the lumbar support

Rotate the lumbar support adjuster (6) for the desired height and curvature of the lumbar support.

6.1.2 Adjusting the steering wheel

CAUTION!



- Avoid injury! Never adjust the steering wheel while the machine is moving. Bring the machine to a standstill before adjusting the steering wheel so as to avoid losing control of the machine.
- Lock the steering wheel in the desired position before driving the machine.

Adjusting the tilting angle

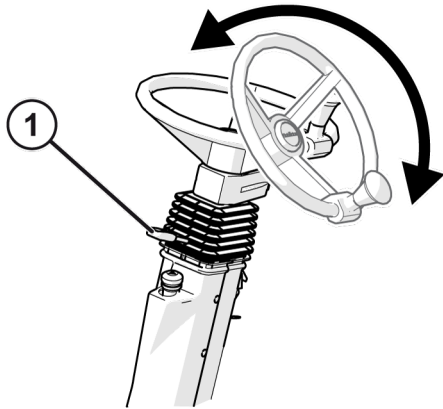

1. Press the lever (1) downwards.
2. Adjust the position of the steering wheel
3. Release the lever to lock the steering wheel in the chosen position.

Adjusting the height setting

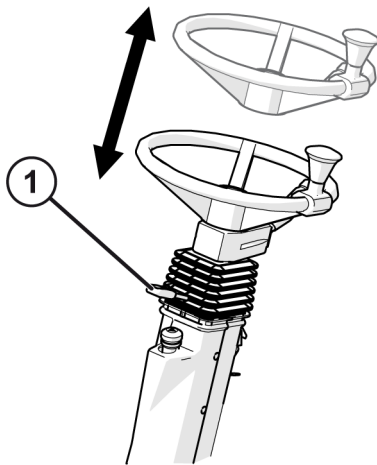

1. Move the lever (1) upwards.
2. Raise or lower the position of the steering wheel.
3. Release the lever to lock the steering wheel in the chosen position.

6.1.3 Use the correct type of fuel (diesel)

Use the correct type of fuel to ensure the best performance of the engine and to limit exhaust gases. If you do not observe the fuel requirements given below, the warranty will be invalidated.

Check the properties of the diesel that is available in your region with your local fuel supplier.

In general, diesel is mixed so that the mixture meets the requirements for the lowest outdoor temperature in the region where the diesel is sold.

Required diesel properties

It is recommended to use diesel which satisfies EN 590. The fuel must have the following properties:

- *The cold filter plugging point (CFPP)* must be at least 5 °C below the expected lowest temperature or the *floc point* must be below the lowest ambient temperature.
- *The fuel's lubricating capability* must be able to withstand a maximum scratch diameter of 0.45 mm as measured according to ISO 12156-1.



WARNING Be careful with fuel. Do not refuel when the engine is running. Do not smoke when refuelling or when performing maintenance on the fuel system.

CAUTION!



Using the wrong fuel additives may damage the engine's fuel injection equipment.
Never mix diesel with engine oil or another kind of lubricating oil, as this will damage the engine.

Sulphur content

The quality and sulphur content of the diesel used must meet all the regulations concerning emissions applicable in the region where the machine is used.

Only use diesel with an ultra-low sulphur content (maximum 0.0015% [15 mg/kg]).

Using biodiesel

Biodiesel may only be used if its properties meet the most recent version of EN14214 or similar specifications.

The current maximum permitted biodiesel concentration is a 5% mixture (also called B5) with normal petroleum diesel.

Concentrations up to B20 may be used if the machine is modified with the original Yanmar B20 kit (KIT-V384BGS-BI).

The use of B6-B20 fuel requires a different maintenance interval for some components and special procedures for fuel transport and machine storage.

Ask your Roberine dealer if you wish to know whether the recommendations for the use of biodiesel have changed.

6.2 Testing the safety system

WARNING Avoid injury! The exhaust gases from the engine contain carbon monoxide and can cause serious illness or even death.



- If possible, move the machine outdoors before starting the engine.
- Never run the engine in an enclosed space without sufficient ventilation. If there isn't sufficient ventilation, connect an extension hose to the engine's exhaust so that the exhaust gases are removed from the room.
- Allow fresh air to enter the workplace so that the exhaust gases are expelled.

The machine's safety systems must be tested every time before the machine is used. Carefully read the machine's instruction manual and make sure you are familiar with how the machine works before testing the safety systems.

Use the following test procedures to check whether the machine works correctly.

Do not use the machine if a fault is discovered during one of these procedures. Ask your authorised Roberine dealer for maintenance advice.



CAUTION! Perform the tests in an area without obstacles, keep a minimal clearance of 5 metres. Keep bystanders away from the area.



NOTICE Refer to *Command arm* on page 21 for the location of the switches.

6.2.1 The parking brake

This procedure describes how to apply and release the parking brake safely.



NOTICE Only apply parking brake when the machine is at a complete stand still.

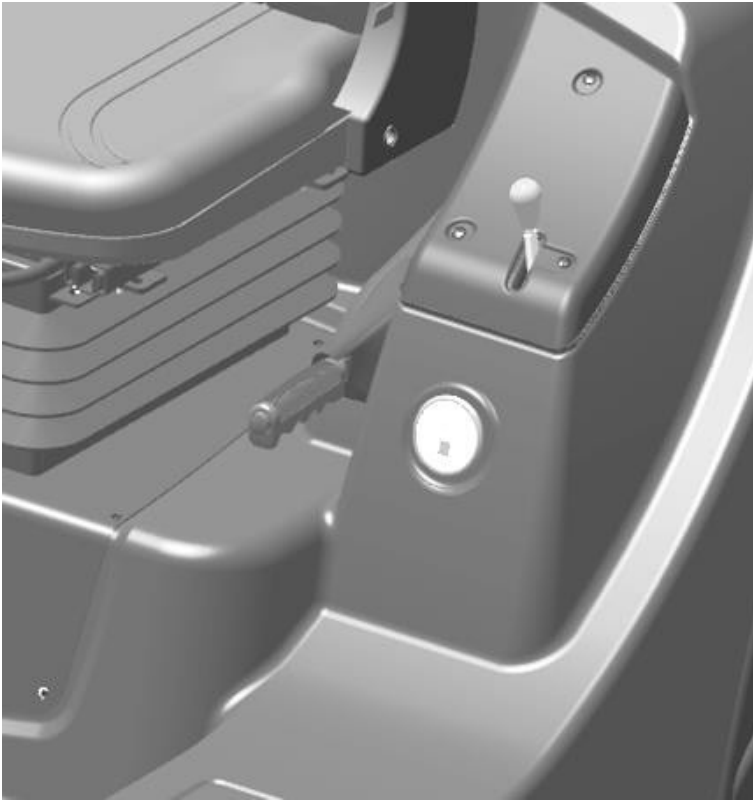

To apply the parking brake:

1. Pull the parking brake lever upwards and secure it in position.

To release the parking brake:

1. Pull the lever upwards slightly.
2. Press the button.
3. Lower the parking brake lever.
4. Release the parking brake lever.

6.2.2 Testing the mowing switch

With this test you will test the functioning of the mowing switch safety circuit.

1. Park the machine safely.
2. Sit on seat.
3. Put the mowing/back lapping switch in the mowing position.
4. Attempt to start the engine.

The engine should not start if the mowing switch is in the mowing position. If the engine does start, there is a problem with the safety circuit. Contact your Roberine dealer for repair.

6.2.3 Testing the parking brake (1)

With this test you will test the functioning of the parking brake safety switch.

1. Park the machine safely.
2. Sit on seat.
3. Release the parking brake.
4. Attempt to start the engine.

The engine should not start if the parking brake has been released. If the engine does start, there is a problem with the safety circuit. Contact your Roberine dealer for repair.

6.2.4 Testing the seat mechanism

With this test you will test the functioning of the seat safety mechanism.

1. Park the machine safely.
2. Sit on seat.
3. Start the engine.
4. Release the parking brake.
5. Stand up, but do not get off the mower.

The seat safety mechanism should stop the engine. If the engine does not stop, there is a problem with the safety circuit. Contact your Roberine dealer for repair.

6.2.5 Testing the drive pedal neutral position

With this test you will test the functioning of the drive pedal safety mechanism.

1. Park the machine safely.
2. Sit on seat.
3. Operate the foot pedal.
4. Attempt to start the engine.

The engine should not start. If the engine does start, there is a problem with the safety circuit. Contact your Roberine dealer for repair.

6.2.6 Testing the parking brake (2)

With this test you will test the functioning of the parking brake in general.

1. Start the engine.
2. Place the machine up hill on an incline of 26 % (15°)
3. Apply the parking brake.
4. Stop the engine.

The parking brake must ensure that the machine remains stationary. If the machine does not remain stationary, there is a problem with the safety circuit. Contact your Roberine dealer for repair.

6.3 Daily checks before use

Before every use, make sure that:

- all protective screens and covers have been fitted.
- there are no loose, missing or damaged parts.
- the safety systems have been tested as described in *Testing the safety system* on page 26.
- the indicators work.
- the engine oil level is correct and add oil if necessary.
- the hydraulic oil level is correct and add oil if necessary.
- there are no hydraulic oil leaks.
- the coolant level is correct and add fluid if necessary.
- the fuel level is sufficient.
- the tyres show no sign of damage and the tyre pressure is correct.
- the wheel bolts are properly tightened.
- the red plunger of the air resistance indicator is not visible.
- there is no dirt on the air intake grill, the radiator and the engine compartment.
- there is no water in the fuel/water separator.
- the rear axle and the rollers and bearings of all mowing units have been lubricated.

7 Operating

In this chapter you will read how to operate the F3 and R3 mower.

7.1 Starting the engine



NOTICE Before you start the engine, make sure that all daily checks as described in *Daily checks before use* on page 28 have been done.

7.1.1 Use of the hand throttle

Use the hand throttle to determine the speed of the engine.



- Push the lever forwards to run the engine at full speed.
- Pull the lever backwards to idle the engine



NOTICE For the best result, always mow with the engine running at full speed.

7.1.2 Turning on the engine

CAUTION!



- If possible, start the machine outdoors.
- Never run the engine in an enclosed space without sufficient ventilation.
- Only start the engine when you are seated and bystanders are at a safe distance.

1. Take place on the seat and fasten the seat belt.
2. Put the ignition key in the ignition. (See *Driver's compartment* on page 20).
3. Apply the parking brake.
4. Put the mowing switch in the NEUTRAL position.
5. Place the hand throttle in IDLE position.
6. Turn the ignition key until the engine starts.

INFO:

- *The starter motor may be damaged if it is used for more than 15 seconds. If the engine does not start, wait 30 seconds before trying again.*
- *In the event of a cold start (< 5° C), allow the engine and hydraulic installation to idle in low revolutions the first minutes.*

7. Release the ignition key.

7.1.3 Turning off the engine

1. Place the foot pedal in the NEUTRAL position.
2. Place the hand throttle in the IDLE position.
3. Put the mowing switch in the NEUTRAL position.
4. Apply the parking brake.
5. Allow the engine to cool down.
6. Turn the ignition key to the OFF position.

7.2 Driving

CAUTION!



- Make sure bystanders are at a safe distance before driving forwards or in reverse.
- Turn off the mowing units before driving in reverse.
- Stop the machine before switching from the mowing speed to the driving speed or vice versa. The driver can be thrown forwards if a different driving speed is selected while driving the machine.

Driving forwards

1. Start the engine.
2. Release the parking brake.
3. Place the hand throttle in the FULL SPEED position.
4. Push the foot pedal forwards.
5. Stop the machine by slowly releasing the foot pedal.

Driving in reverse



NOTICE Turn off the mowing units before driving in reverse.

1. Start the engine.
2. Release the parking brake.
3. Place the hand throttle in the FULL SPEED position.
4. Push the foot pedal backwards.
5. Stop the machine by slowly releasing the foot pedal.

7.2.1 Cruise control

Use the cruise control to save a driving speed and keep driving without using the foot pedal. The cruise control has the following options:

	SET + ↑	
ON/OFF ←	O	→ CANCEL
	↓ RESUME -	

ON/OFF

- Activate the cruise control: the driving speed will not be changed or saved.
- De-activate the cruise control: the saved driving speed will be deleted.

NOTICE The cruise control will be de-activated when:



- The right foot pedal (backwards) is pressed.
- The brake is used.
- The seat is unoccupied.

CANCEL

- De-active the saved driving speed, the saved driving speed will not be deleted.

SET +

- Save the current driving speed.
- Increase the saved driving speed.

RESUME -

- Resume the saved driving speed.
- Decrease the saved driving speed.



NOTICE When using the foot pedal to increase the driving speed, the machine will drive faster. When releasing the foot pedal, the machine will return to its saved driving speed.

7.3 Operating the mowing units

7.3.1 Before you start mowing

Inspect the terrain:

- Remove objects that could be thrown away by the machine from the area to be mowed.
- Keep people and animals out of the area to be mowed.
- Make sure there are no low-hanging branches or similar obstacles that can impair the driver within the area to be mowed. Remove these obstacles.
- Inspect the area to be mowed. Follow a safe mowing pattern. Do not mow in areas where the traction or stability is not sufficient.

7.3.2 Lowering the mowing units

Park the machine in a safe location.

CAUTION! Thrown objects can be dangerous. Before operating the mowing units:



- Make sure nobody is in the work area, particularly children.
- Remove objects that can be thrown away by the mowing units.

Refer to *Description* on page 16 and *Command arm* on page 21 for the location of the levers and switches.

1. Unlock the front mowing units by rotating the locking lever anticlockwise (7).
2. Start the engine.
3. Release the parking brake.
4. Place the hand throttle in the FULL SPEED position.
5. Put the mowing switch (1) in the MOWING position.

6. Put the raising/lowering activation switch (3) in the LOWER position.
7. Push the cross-cut button (9) to activate the lower mowing units/cross-cut option.
8. Operate the raising/lowering switches:
 - a) Push the right hand switch (6) forwards to lower the right hand mowing unit.
 - b) Push the middle switch (7) forwards to lower the middle mowing unit.
 - c) Push the left hand switch (8) forwards to lower the left hand mowing unit.



NOTICE Push all three switches at the same time to lower all the mowing units together.

7.3.3 Raising the mowing units

Park the machine in a safe location.

Refer to *Description* on page 16 and *Command arm* on page 21 for the location of the levers and switches.

To raise all mowing units at the same time:

1. Place the hand throttle in the FULL SPEED position.
2. Push the cross-cut button (9) to activate the lower mowing units/cross-cut option.

All mowing units will raise and stop the cylinders will stop.

The mowing units will raise until you release the cross-cut button (9) or when they reach the highest point.

To raise individual mowing units:

3. Put the raising/lowering activation switch (3) in the RAISE position.
4. Operate the raising/lowering switches:
 - a) Push the right hand switch (6) forwards to lower the right hand mowing unit.
 - b) Push the middle switch (7) forwards to lower the middle mowing unit.
 - c) Push the left hand switch (8) forwards to lower the left hand mowing unit.
5. Lock the mowing units by rotating the locking lever (7) clockwise.

7.3.4 Cross cut option

By operating the cross cut button the mowing units will raise momentarily and lower again quickly. All mowing units of which the matching switch is pushed forwards will raise or lower whenever the button has been activated.



NOTICE Refer to *Command arm* on page 21 for the location of the cross cut button.

1. Press the cross-cut button (9) briefly to raise the mowing units 30 cm.
2. Hold the cross-cut button to raise the mowing units completely.
3. Press the button again to lower the units from any position.



NOTICE The cross-cut button can be useful when you quickly need to raise the mowing units in order to drive in reverse or turn around.

7.3.5 Adjusting the cutting height

CAUTION!



- Always wear protective gloves when performing a service function on or near a mowing unit. Severe injury can result from contact with sharp cutting edges.
- When a cutting cylinder is rotated by hand it is possible that the other cutting cylinders will also rotate.

Before you begin: Park the machine in a safe location. Turn off the cutting cylinders, turn off the engine, and remove the ignition key.

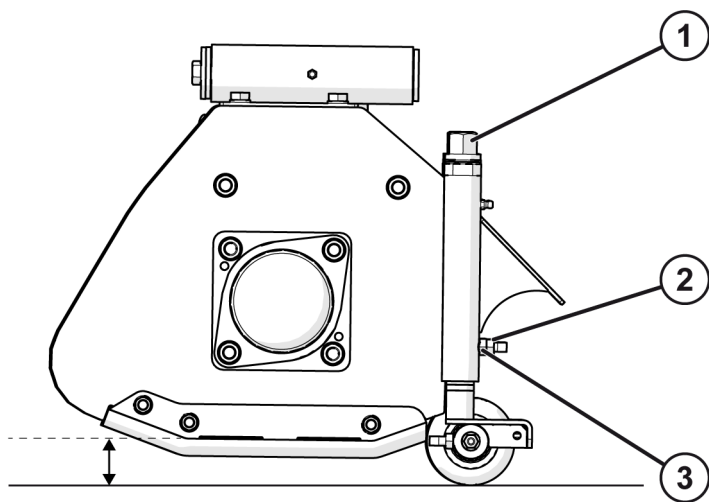

1. Clean the mowing units. See *Cleaning the mowing units* on page 49.
2. Place a flat plate under the mowing units or make sure the units are located above a flat surface.
3. Loosen nut (3).
4. Loosen nut (2) a quarter of a revolution.
5. Set the required cutting height by turning bolt (1):

- Clockwise to lower the cutting height.
- Anticlockwise for a higher cutting height.
- Each full rotation equals 2 mm height adjustment.

6. Measure the cutting height:

- F3: from the top of the drag rod (minus 5 mm) to the ground.
- R3: from top of the bed knife to the ground.

NOTICE Measure the cutting height on both sides of each unit for an equal cut.

7. Tighten bolt (2) with 25 Nm
8. Tighten bolt (3) with 25 Nm

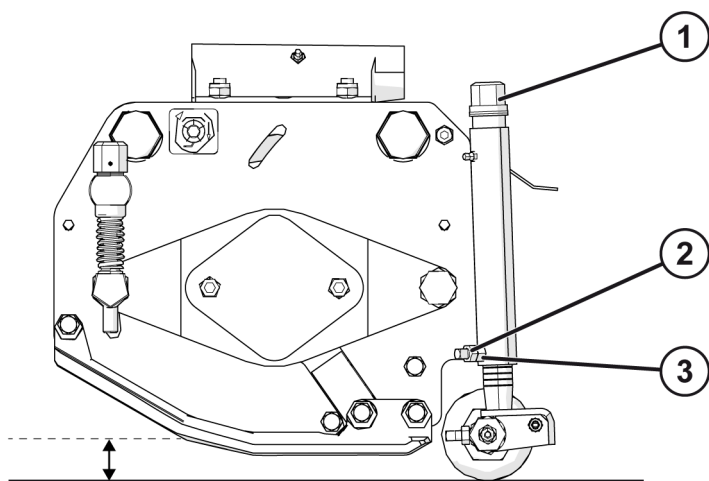

7.4 Use of the weight transfer system

Use the weight transfer system to increase traction on the wheels or the mowing units.



- Push the weight transfer switch forwards to transfer the weight to the wheels and, therefore, increase traction.
- Push the weight transfer switch (1) backwards to transfer the weight to the mowing units

7.5 Operating the free-wheeling mechanism

Your machine is provided with special tools required to enable free-wheeling of the front wheel motors.

Follow this procedure if your machine breaks down while on an incline.

WARNING



- With the free-wheeling tools installed, the machine will have unrestricted motion. If machine is on an incline it may free-wheel out of control after unlocking the wheel motors. Prevent machine from free-wheeling by mounting a rigid tow bar onto another machine.
- Do not tow the machine more than necessary. Towing the machine may cause damage to the hydraulic system. The machine can be towed over a maximum distance of 1,000 m at a maximum speed of 2 km/h.

Turning on the free-wheeling mechanism

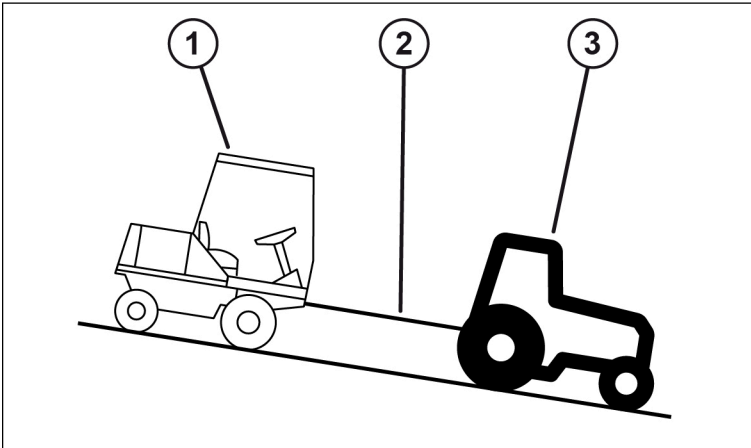

Before you begin:

1. Block the wheels.
2. Attach the mower (1) onto another machine (3) using a rigid tow bar (2) to prevent unintentional free-wheeling of the mower.



NOTICE The free-wheeling mechanism can be accessed at the front of the machine on the left-hand side between the mower unit and the front wheel. Nothing has to be disassembled to access the mechanism.



1. Place the wheels in the straight-ahead position by turning the steering wheel.
2. Rotate the tap clockwise until it is tightened.
3. Place the lever at a 90° angle to the driving direction.



CAUTION! The machine can now move unrestrictedly.

4. Rotate the steering wheel 90° clockwise until you feel a slight resistance.



CAUTION! Do not use strong force to rotate the steering wheel, this can damage the front wheel motors.

5. Place the lever back in the driving direction.

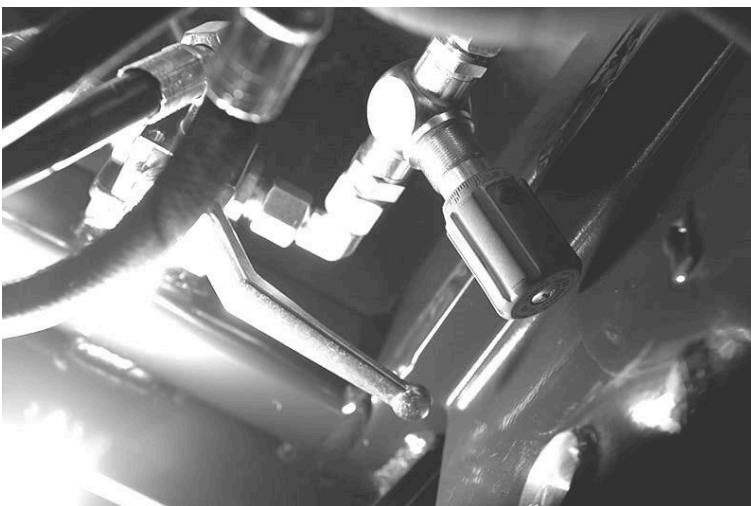

NOTICE The machine can now be towed. Remember that the machine now steers heavily, has a maximum speed of 2 km/h and a maximum distance of 1,000 m.

Turning off the free-wheeling mechanism

Rotate the tap (1) anticlockwise until it can go no further.

The free-wheeling mechanism is now deactivated and the machine has been returned to its original settings.

7.6 After operating the machine

When you are finished operating the machine, please make sure that you:

- park in a safe and secure location.
- turn off the engine and remove the ignition key.
- clean the mowing units (see *Cleaning the mowing units* on page 49).
- refuel the diesel tank (see *Refuelling* on page 65).

8 Maintenance

Professional, regular maintenance of your mower is important. A well maintained mower will enable you to work safer and better. Moreover, good maintenance results in longer service life, reduces the extent of any damage and eliminates costly, time-consuming repairs. This chapter provides information about the maintenance you must perform daily and at other regular intervals. These are simple maintenance tasks, yet they are nevertheless important. It is therefore strongly recommended that the maintenance recommendations be strictly adhered to and carried out for you. Roberine has an excellent dealer network with trained service engineers who perform maintenance and repairs for you.

8.1 The bonnet



To open the bonnet:

1. Rotate the lock clockwise to unlock the bonnet.
2. Lift the bonnet.

To close the bonnet:

1. Carefully lower the bonnet.
2. Rotate the lock anti-clockwise to lock the bonnet.

8.2 The hour meter

The hour meter counts hours that the engine has run. Use the hour meter and the maintenance interval table to determine when you need to do maintenance on the machine and the mowing units.

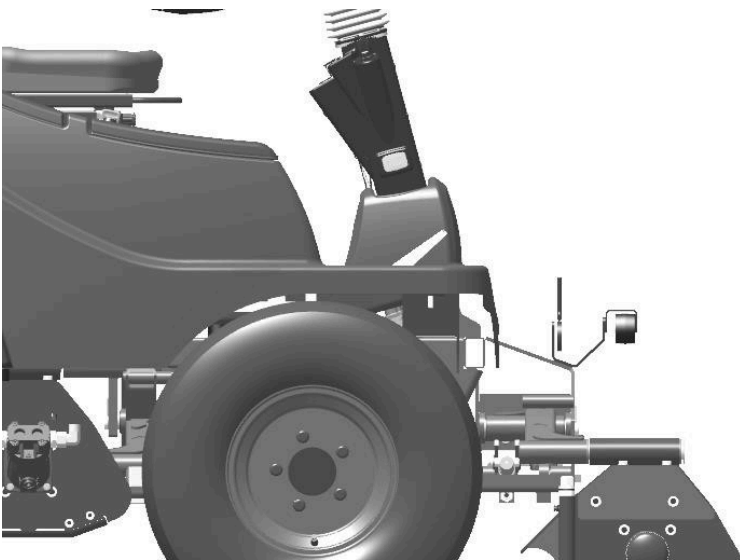

To read the hour meter:

1. Make sure the parking brake is applied.
2. Place the key in the ignition and turn it in the ON position.

8.3 Maintenance intervals

Use the following maintenance interval tables for routine maintenance of your machine.



NOTICE Under extreme circumstances, additional maintenance services may be required:

- Extreme heat, excessive dust or other extreme conditions may cause engine parts to become dirty or blocked.
- The quality of the engine oil may be reduced if the machine is constantly driven too slow or at a low engine speed, or if it is intensively used for short periods of time.

8.3.1 After the first 5 hours

Material	Maintenance type
Tyres	Inspect for damage and wear, replace if necessary.
Tyre pressure	Check if they are at the correct pressure
Mounting materials	Inspect and adjust if necessary.
Hoses	Inspect for damage and wear, repair or replace if necessary.
Drive wheel bolts	Inspect and adjust if necessary.
Parking brake	Check its functioning.
Hydraulic system	Check for oil leaks

8.3.2 Daily maintenance

Material	Maintenance type
Engine air filter	Clean.
Cabin air filter	Clean.
Cooler	Clean.
AC cooler on cabin roof	Clean.
Engine coolant	Check and refill. See <i>Cooling system</i> on page 45.
Lubrication points	See <i>Lubrication</i> on page 40.

8.3.3 After the first 50 hours

Material	Maintenance type
Air intake and coolant hose clips	Inspect and replace if necessary.
Fuel/water separator	Inspect and drain if necessary.
Engine oil & oil filter	Replace.
Hydraulic filters	Replace.
Fan belt	Check the tension.
Fan belt	Inspect for damage and wear and replace if necessary.

8.3.4 Every 50 hours

Material	Maintenance type
Lubrication points	Lubricate (see also <i>Lubrication</i> on page 40).
Parking brake switch	Check its functioning.
Battery	Inspect.
Hoses	Inspect for damage and wear, repair or replace if necessary.
Hydraulic system	Check for oil leaks
Sealing surfaces from the bonnet to the cooler	Inspect for damage and wear, adjust if necessary.
Drive wheel bolts	Inspect and adjust if necessary.
ROPS	Inspect the system for damage and wear. Maintenance may only be done by you Roberine dealer.
Mowing units	Inspect the mounting materials and adjust if necessary
Bonnet	Clean under the bonnet and check lock.
Flails	Check for wear and damage.

8.3.5 Every 250 hours

Material	Maintenance type
Engine oil & oil filter	Replace.
V-belt	Inspect for damage and wear.
V-belt	Check the tension
Air intake hoses, hydraulic lines and hoses, radiator hoses and hose clips	Inspect for damage and wear, replace if necessary.
Radiator fins	Check and clean. See <i>Cleaning the air intake grill and engine cooler</i> on page 44.

8.3.6 Every 500 hours or once a year

Material	Maintenance type
Hydraulic oil & filters	Replace.
Coolant	Inspect clarity and the freezing point, replace if necessary.
Fuel filter	Replace. See <i>Fuel filter and fuel/water separator</i> on page 46 .
Engine oil and filters	Replace. See <i>Changing the engine oil and filter</i> on page 43 ¹ .
Battery terminals	Inspect.

1. May differ depending on the application or engine oil capacity. If the engine is equipped with a shallow oil sump, the maintenance interval should be every 250 hours.

8.3.7 Every 1,000 hours

Material	Maintenance type
Valve clearance	Contact your Roberine dealer.
Intake and exhaust cylinder head valve clearance	Contact your Roberine.

8.3.8 Every 1,500 hours or every 2 years

Material	Maintenance type
Fuel injectors	Contact your Roberine dealer.
Battery terminals	Clean.

8.3.9 Every 2,000 hours or every 2 years

Material	Maintenance type
Coolant	Replace.
Thermostat	Replace.

8.3.10 Every 3,000 hours or every 3 years

Material	Maintenance type
Diesel injection pump	Inspect. See the technical instruction manual, or contact your Roberine dealer.

8.4 Lubrication

8.4.1 Lubricants

Roberine recommends the following types of lubricants:

Mowing units	Connections between the hydraulic motor and the rotor clutch
Polyurea – NLGI-class 0	
Calcium Complex – NLGI class 0	

Do not combine

Do not mix other types of lubricants (including lubricants with a calcium, lithium and lithium 12-hydroxyl base) with the lubricants recommended above; they cannot be combined. For the best result, fully remove the lubricants that cannot be combined from the housing and apply a lubricant recommended above. Do not use biolubricants.

Weather conditions

The types of lubricants recommended by Roberine are suitable for an average temperature of between -29 °C and 135 °C. When using the machine in a temperature outside of this range, please contact your maintenance dealer for special types of lubricants. Lubricants that meet military specification MIL-G-10924F can be used in extremely cold conditions.

8.4.2 Lubrication points

The following points need to be lubricated regularly:

- | | | | |
|---|--------------|---|----------|
|  | Daily |  | Weekly |
|  | Twice a week |  | Annually |

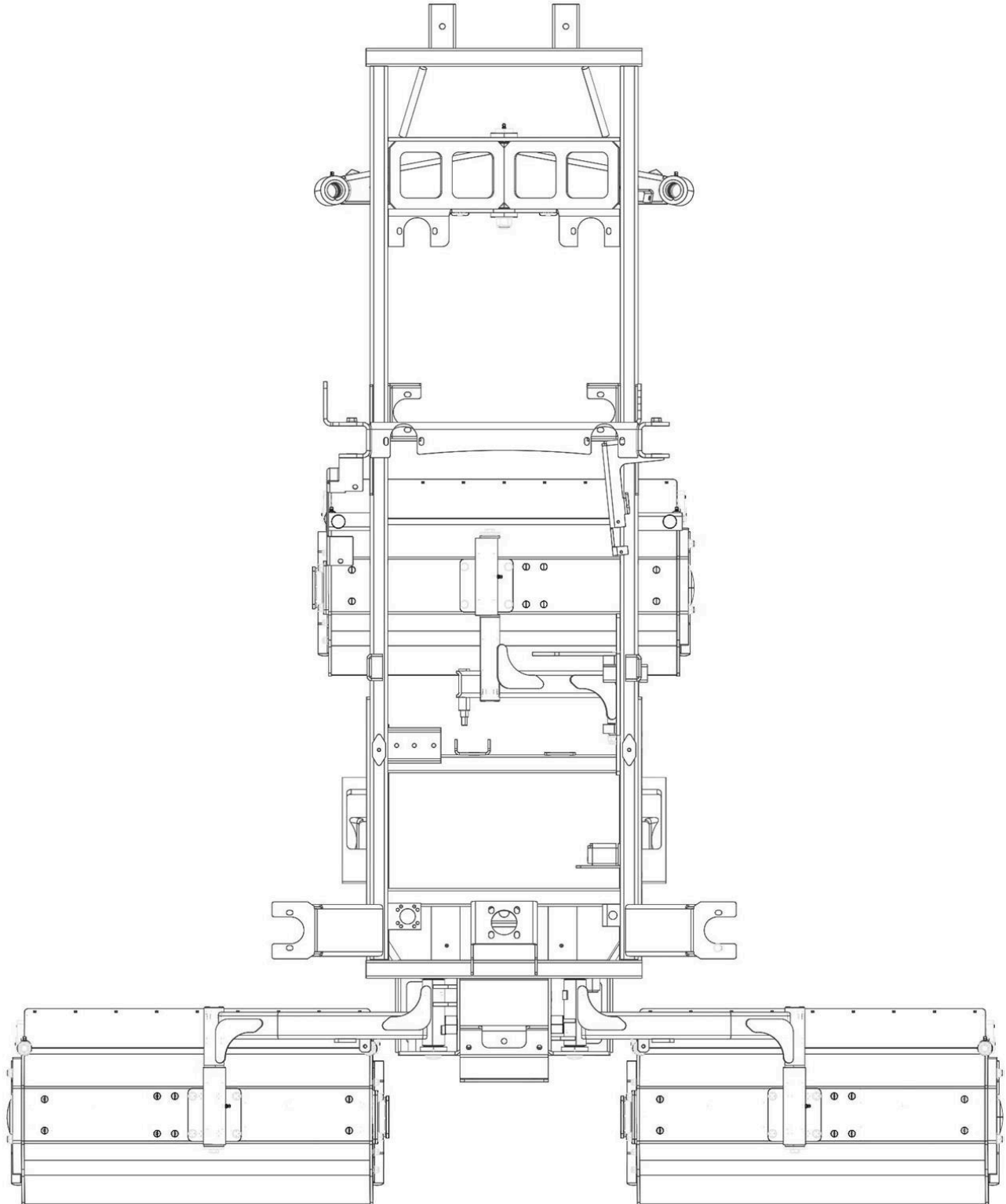

8.5 Engine oil

Use oil with a suitable viscosity grade for the expected outdoor temperature in the period between oil changes.

Preferably use one of the following types of oil specified by Yanmar:

- API maintenance classification CF or higher.
- ACEA E-3 or higher.

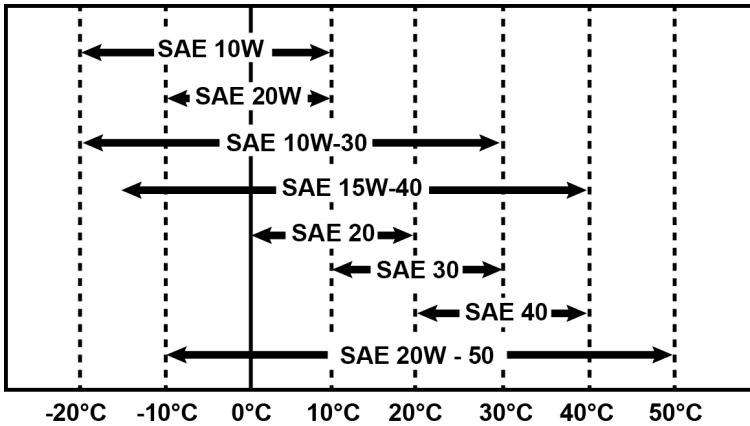

NOTICE See the Yanmar Engine Manual for more specified information.

8.5.1 Checking the engine oil level

Regularly check the oil level. Engine problems may occur if the oil level is too low. Check before every use and twice a day if you run the engine for more than four hours a day.

Before you begin: Make sure the machine is parked safely on an even surface and the engine is cold.

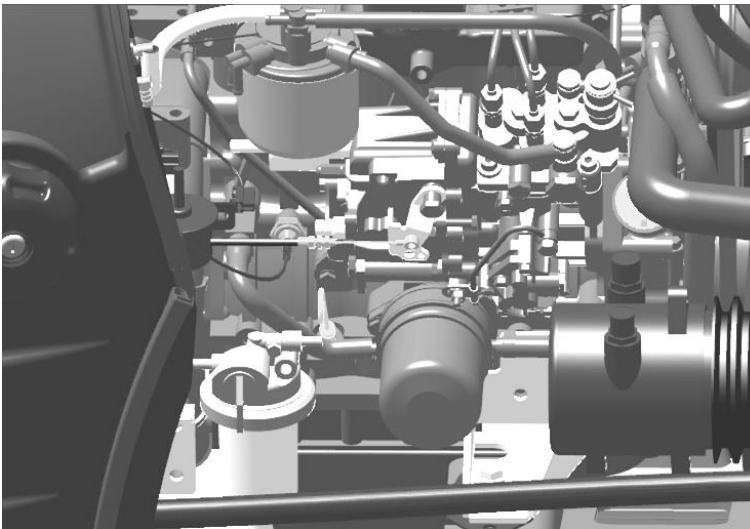

1. Open the bonnet.
2. Clean the area around the dipstick.
3. Pull out the dipstick and wipe it dry.
4. Insert the dipstick back in its place.
5. Pull out the dipstick and check the oil level.

The level must be between the two lines.

- If the oil level is too low, add oil until the level is not higher than the upper line on the dipstick.
 - If the oil level is above upper line, drain the oil until it is at the correct level.
6. Insert the dipstick back in its place.
 7. Close the bonnet.

8.5.2 Changing the engine oil and filter

Change the oil more often if the vehicle is used in extreme conditions such as extreme dust, frequent slow or low-speed use or frequent short trips.

Before you begin: Run engine to warm the oil and park it safely.

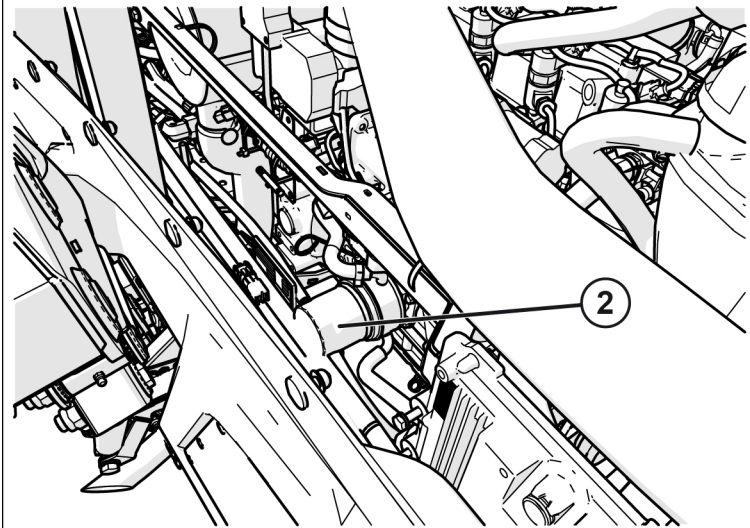
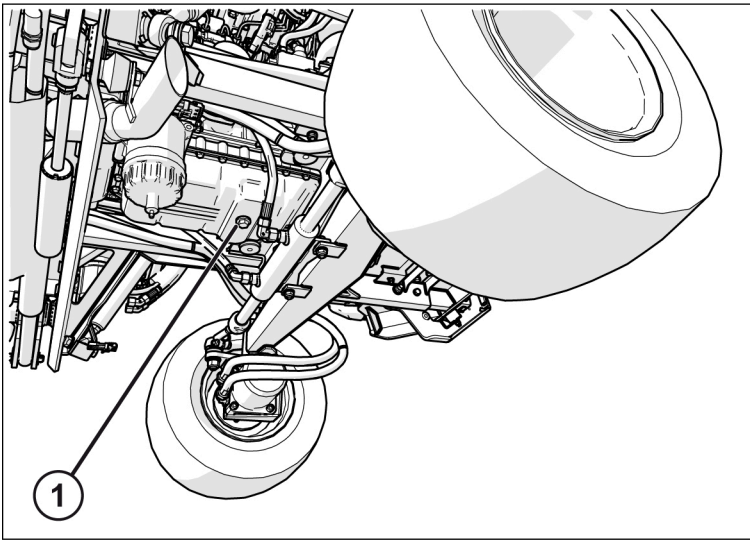

1. Clean the drain plug (1) and the area around it.
2. Place a drain pan under the oil drain location:
3. Remove the drain plug to drain the oil.
4. Remove the oil filter (2) by turning it counterclockwise.
5. Apply a film of clean engine oil on the seal of the new filter.
6. Install the new filter. Turn the filter until the seal contacts the mounting surface. Tighten 1/2-3/4 turn after gasket contact.
7. Install drain plug.
8. Remove filler cap. Add approximately 4.8 litre of oil.
9. Check the oil level according to *Checking the engine oil level* on page 42.
10. Install and tighten the filler cap.
11. Run the engine at slow speed for two minutes. Check for leaks around the filter.
12. Stop the engine, wait a few minutes and check oil level again. Add oil if necessary. Do not overfill.

8.6 Cleaning the air intake grill and engine cooler

It is important to keep the air intake grills and the engine's other exterior surfaces (including the engine cooler) clean to allow adequate air intake. An obstructed air intake grill can cause engine damage due to overheating.

CAUTION! Compressed air can cause debris to fly a long distance. Make sure that:



- there are no bystanders;
- you wear eye protection;
- you reduce the compressed air pressure to 210 kPa (30 psi).

Before you begin: Park the machine in a safe location.

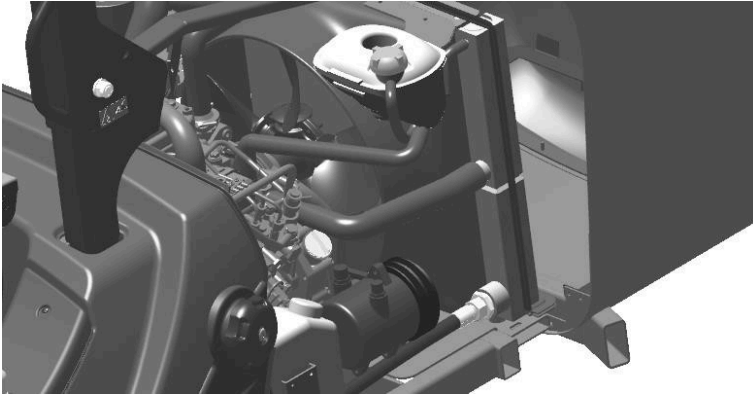

1. Open the bonnet.
2. Use compressed air to blow the radiator clean from the inside out (see the arrow).
3. Use a brush to clean the back of the radiator.
4. Use a brush or compressed air to clean the radiator fins.
5. Clean the inside and outside of the intake grills.
6. Close the bonnet.

8.7 Checking the air resistance indicator

Clean the engine air filter on a daily basis. Regularly check the air resistance indicator to determine if the filter needs replacing.

Before you begin: Park the machine in a safe location and let the engine cool down.

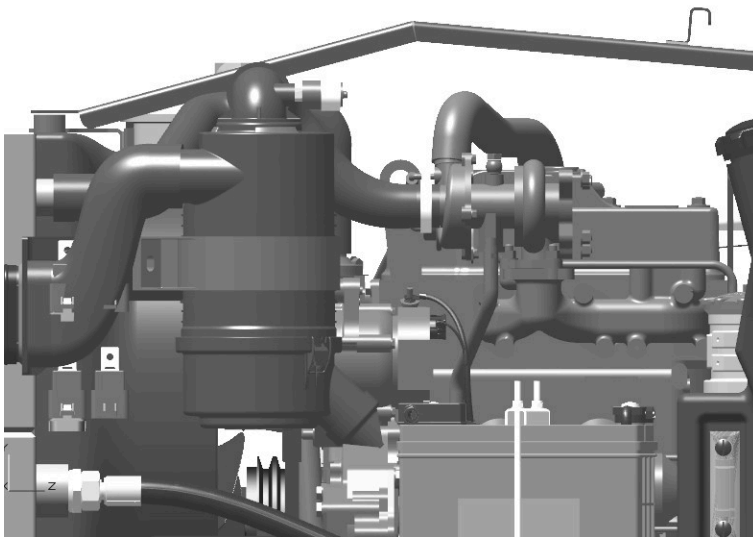

1. Open the bonnet.
2. Check the air resistance indicator (1).
 - If the red plunger in the indicator is visible, the air filter requires immediate maintenance.
3. Replace the air filter if necessary.
4. Close the bonnet.



NOTICE The indicator does not work correctly if the indicator housing is cracked or broken.

8.8 Cleaning the dust unloading valve

Before you begin: Park the machine safely and let the engine cool down.

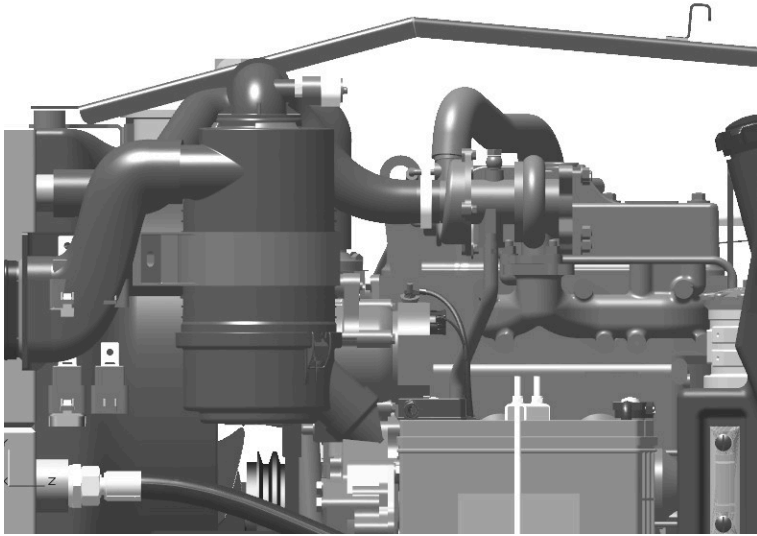

1. Open the bonnet.
2. Squeeze the dust unloading valve (1) to clean it.
3. Remove and replace if it is damaged.
4. Check the inside of the cyclone filter cap.
5. Clean primary filter.

8.9 Cooling system

Roberine recommends the following coolant:

- Havoline AFC + B 50/50 (BL01)

If the recommended coolant is not available, use a low silicate ethylene glycol base coolant concentrate in a 50% mixture of concentrate with quality water. This provides freeze protection to -37 °C.

Use a coolant with a conditioner or add conditioner before use.

In certain regions, protection against lower temperatures may be required. Read the label on the coolant packaging or contact your authorised service centre for the most recent information and recommendations

8.9.1 Checking the coolant level



CAUTION! The radiator will be hot and can burn skin. Built-up pressure may cause explosive release of coolant when the radiator cap is removed.

Before you begin: Park the machine safely and let the engine cool down. Make sure the engine and radiator have cooled to such an extent that they can be touched with bare hands.

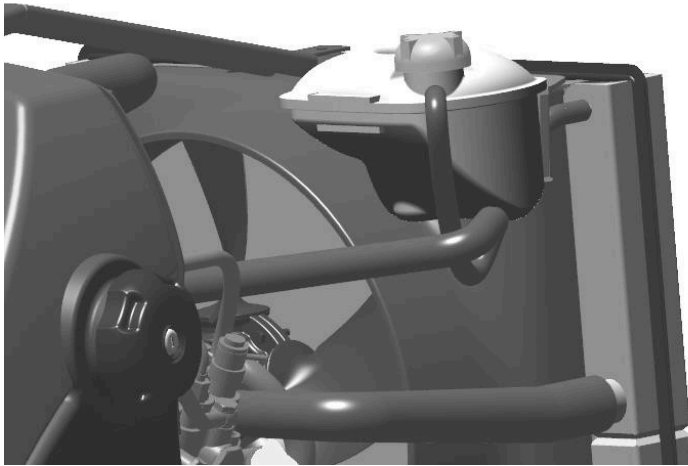

1. Open the bonnet.
2. Slowly unscrew the cap as far as the first stop to allow the pressure to escape.
3. Remove the cap from the recovery tank (1).
4. Check the coolant level.

The coolant should be between the maximum and minimum level.

5. If coolant level is low, add coolant.
6. Install and tighten the cap
7. Remove any dirt from the air intake grill and the radiator.
8. Inspect the hoses for leaks and loose connections.
9. Close the bonnet.

8.10 Fuel filter and fuel/water separator

Inspect the fuel/water separator after the first 50 hours of use. Replace the fuel filter every 500 hours or once a year.

Before you begin: Park the machine safely and let the engine cool down.

Replacing the fuel filter



NOTICE Make sure the fuel level is low before you replace the fuel filter.

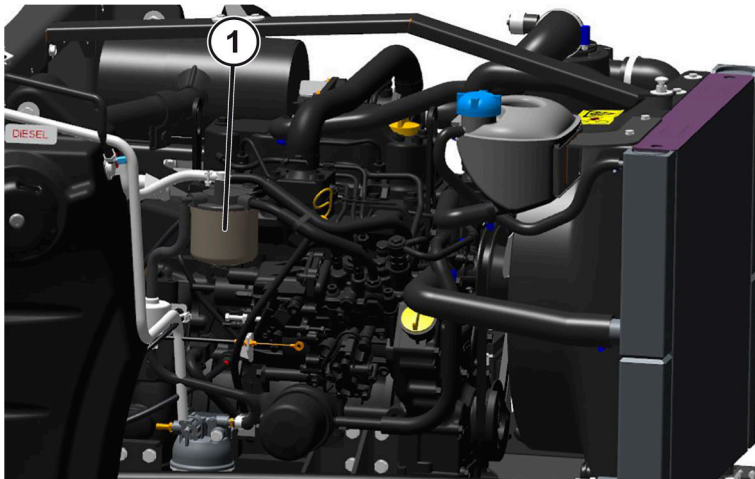

1. Open the bonnet.
2. Unscrew the fuel filter (1) and remove it.
3. Install new fuel filter.
4. Check the deposit container.

Checking the fuel/water separator

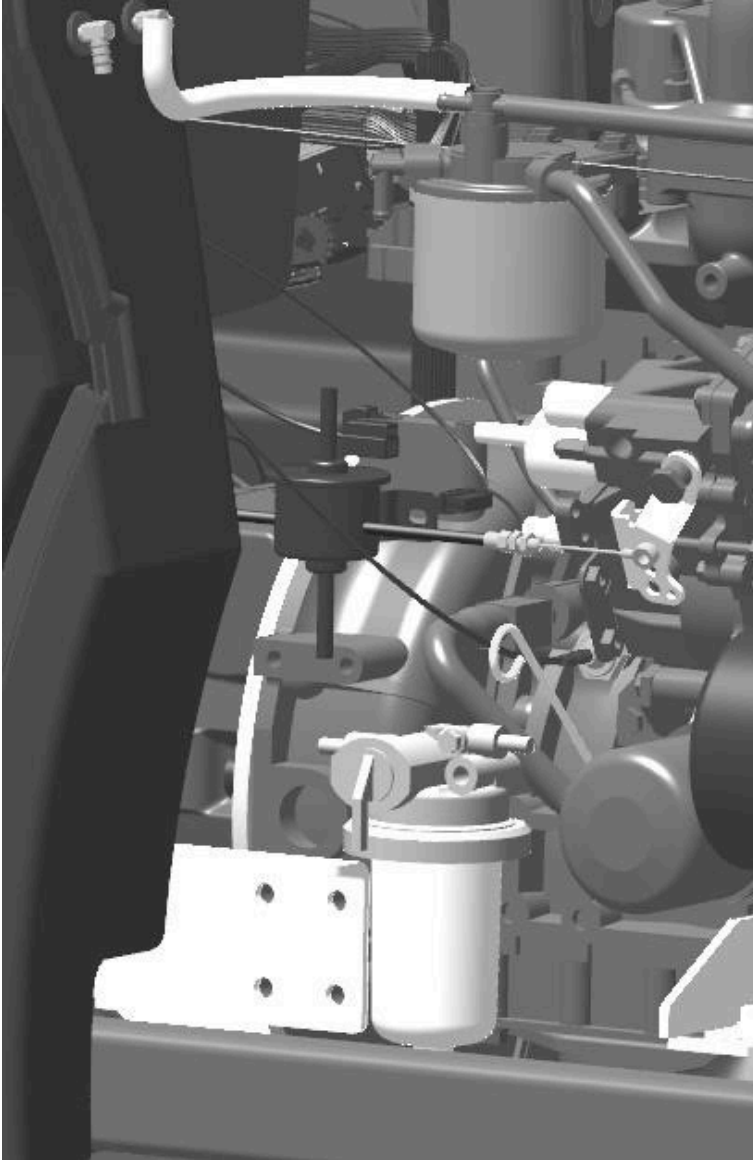

1. Check if there is any water in the fuel/water separator.
The red ring inside will float on water.
2. If necessary, drain the water via the tap or clean the fuel/water separator and replace the filter:
 - a. unscrew the container from its top.
 - b. replace the filter.
 - c. screw the top back onto the container.
3. Close the bonnet.



NOTICE Tightening torque of the fuel/water separator attachment strap: 15-20 Nm.

8.11 V-belt

Inspect the V-belt every 250 hours for wear. For more specified information, see your Yanmar Engine Manual

Before you begin: Park the machine safely and let the engine cool down.

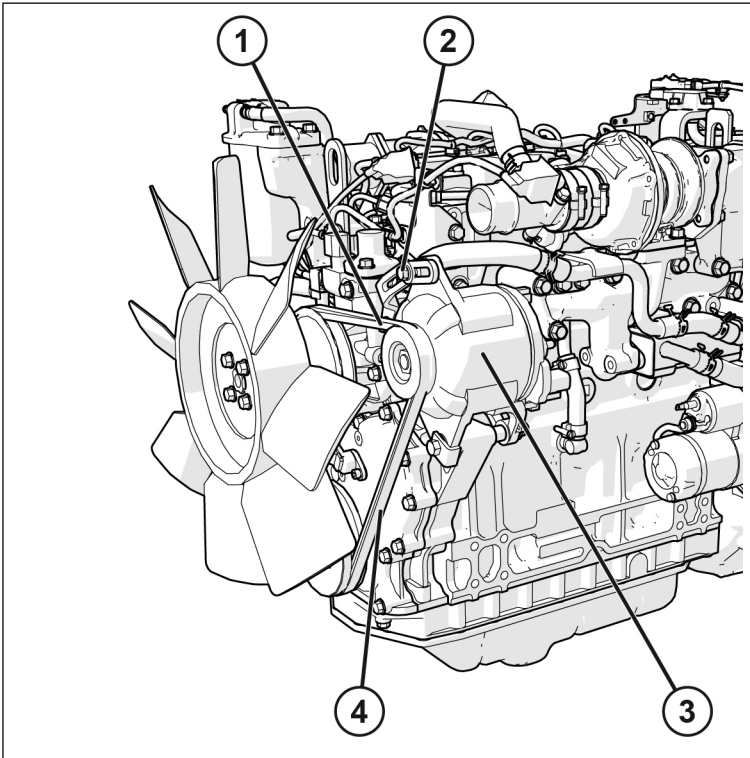

1. Open the bonnet.
2. Inspect the V-belt:

- There are no visible cracks or hair lines.
- The belt is not stretched:

Apply approximately 98 N to the belt at the midpoint between the fan and the alternator pulley. Check belt deflection (1) using thumb compare to specification.

3. Contact your Roberine dealer if the V-belt requires maintenance.

1. V-belt tension
2. V-belt adjuster screw
3. Alternator
4. V-belt

8.12 Transmission and hydraulic oil

Change the hydraulic oil every 500 hours or once a year.



NOTICE Only use the recommended oil, see *Technical specifications* on page 22. Do not use engine oil or “Type F” automatic transmission oil.

Check the hydraulic oil level

Before you begin: Park the machine safely and let the engine cool down.



1. Check oil at gauge:
 - The oil level must be between minimum and maximum markings.
2. Add oil if necessary.

8.13 Cleaning the mowing units

Clean the mowing units after every use.

CAUTION!



- Always wear protective gloves when performing a service function on or near a mowing unit. Severe injury can result from contact with sharp cutting edges.
- When a mowing unit is rotated by hand it is possible that the other mowing units will also rotate.

Before you begin: Park the machine safely, turn off the engine and the mowing units. Make sure the mowing units have come to a complete stop. Remove the ignition key.

1. Rinse the mowing units with low-pressure water.
2. Lubricate the mowing units. Refer to *Lubrication* on page 40.

8.14 Checking and replacing the flails

If the flails are lost, damaged or worn too much, they must be replaced to prevent damage to the rotor shaft due to imbalance.

Maximum flail wear

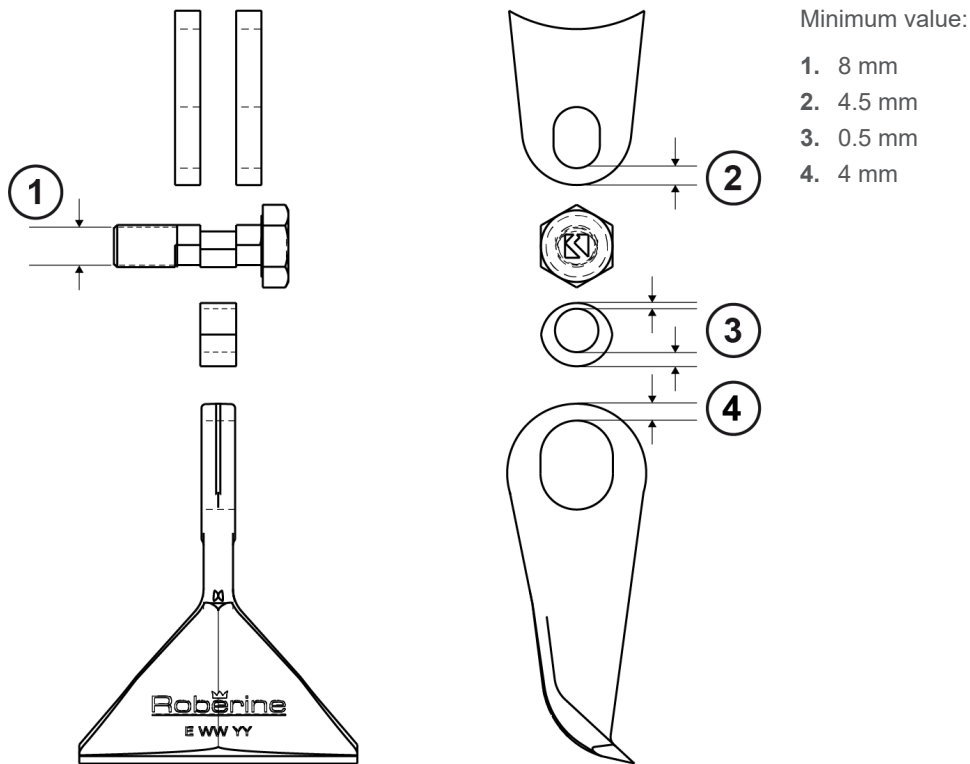

Replacing the flails

Before you begin: Park the machine safely and let the engine cool down.

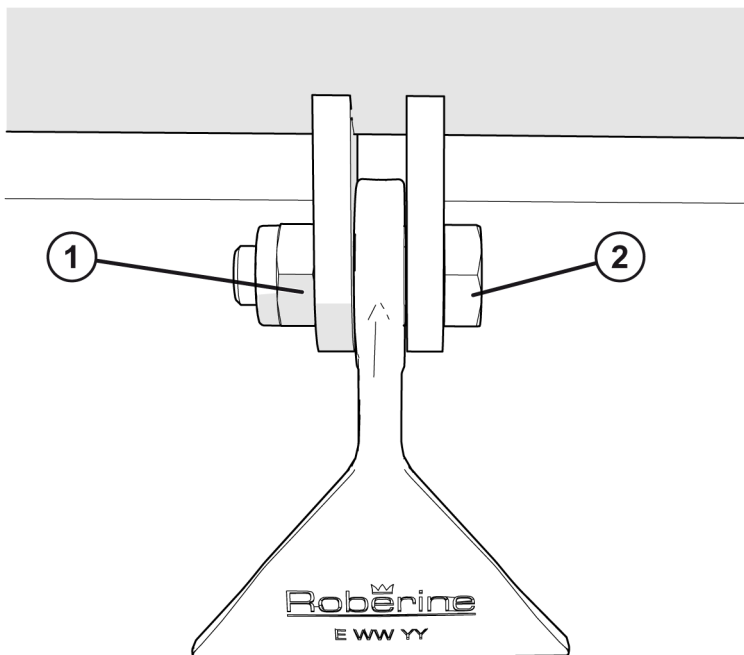

8.15 Maintaining the reels

8.15.1 Checking the mowing units

Check the mowing units regularly to ensure the cutting quality.

CAUTION!



- Always wear protective gloves when performing a service function on or near a mowing unit. Severe injury can result from contact with sharp cutting edges.
- When a mowing unit is rotated by hand it is possible that the other mowing units may rotate as well.

Materials needed:

- Several strips of paper (80 g/m²).

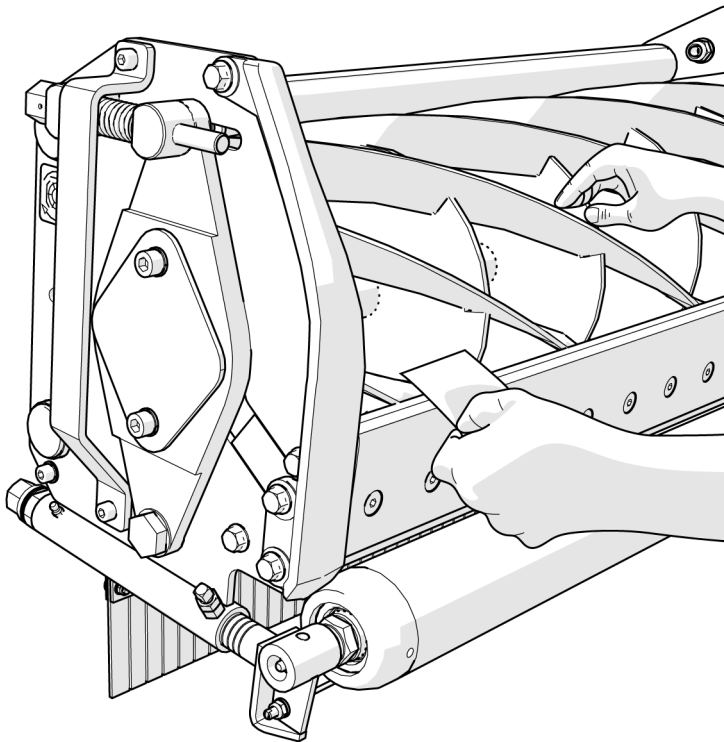

1. Raise the mowing units to get access to the underside of the mowing units.
2. Lock the front mowing units with the transport and safety brackets.
3. Park the machine safely, turn off the engine and remove the ignition key.
4. Place a double-folded sheet paper at a right angle on the bed knife.
5. Turn the mowing unit (very carefully!) by hand in the cutting direction.

The paper sheet should be cut cleanly over its entire length.

6. Repeat steps 4 and 5 over the entire length of the bed knife.

The adjustment is correct when at least one sheet of paper is cut completely. A slightly audible contact between the cutting knife and the bed knife is allowed. When no paper strips are cut completely or the cutting knife and bed knife overlap, adjust the cutting cylinders.

8.15.2 Adjusting the cutting knife to the bed knife

Before you begin: Park the machine safely, lower the mowing units and turn off the engine. Make sure that the mowing units have come to complete stop.



1. Rotate bolt 1 to adjust the cutting clearance:
 - Clockwise: reducing the cutting clearance.
 - Counter clockwise: increasing the cutting clearance.
2. Repeat for bolt 2.
3. Repeat the checking procedure until you reach the desired results.



NOTICE Interchange the starting points every time you adjust the cutting cylinders. This prevents uneven wear of the cutting knives.

8.15.3 Adjusting the grass deflector and scraper

You can adjust the grass deflector in accordance with the grass properties.

For a clean and smooth roller it is important to keep the scraper at the correct tension.

Before you begin: Park the machine safely, lower the mowing units and turn off the engine. Make sure that the mowing units have come to complete stop.

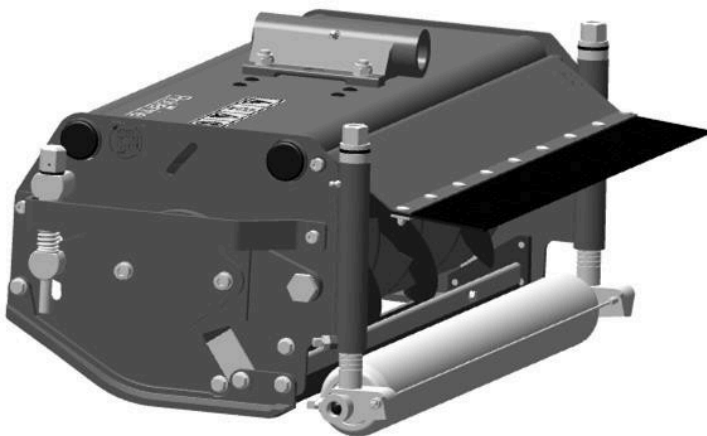

To adjust the grass deflector:

1. Tilt the grass deflector (1) by hand in the required position.

To adjust the scraper:

1. Turn the nuts (2) clockwise to tighten the scraper.



CAUTION! Do not over-tighten the scraper to prevent material damage.

8.15.4 Back lapping the cutting knives

Back lapping the cutting knives regularly will extend the life of the cutting units and provide a good cutting quality. This procedure must be done by experienced and qualified technicians. Every mowing units needs to be back lapped separately.

CAUTION!

- Always wear protective gloves when performing a service function on or near a mowing unit. Severe injury can result from contact with sharp cutting edges.
- When a mowing unit is rotated by hand it is possible that the other mowing units will also rotate.

Materials needed:

- Grinding paste: Grain 80 or 120
- Long handle brush

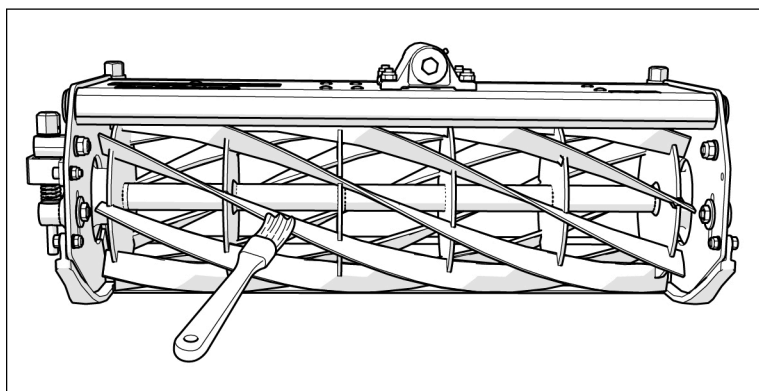

Before you begin:

- Make sure that the mowing units are clean and adjusted properly (See *Adjusting the cutting knife to the bed knife* on page 52).
- Park the machine safely and turn off the engine.
- Raise and lock the front mowing units (See *Transport* on page 66).

1. Apply the parking brake.
2. Start the engine, let it run idle.
3. Put the Raising/lowering activation switch in the ON position.
4. Put the Raising/lowering switch in the ON position.
5. Lower all mowing units by pressing the Cross Cut button.
6. Put Raising/lowering switches in the OFF position.

The rear right and left mowing units stay in the mowing position.

7. Put the Mowing/back lapping switch in the BACK LAPPING position.
8. Step off the machine.
9. Press the cross-cut button.

The rear right mowing unit starts turning backwards.

10. Apply grinding paste to the rear right mowing unit with a brush.



NOTICE Apply the paste equally and over the entire length of the cutting knives.

11. Repeat until you no longer hear a grinding noise.



NOTICE Reduce the cutting clearance to get a better result.

12. Put Raising/lowering switch in the OFF position.

The mowing units will stop turning.

13. Continue with **Back lapping the rear left mowing unit**.

Back lapping the rear left mowing unit

1. Put Raising/lowering switch in the ON position.
2. Press the cross-cut button.

The rear left mowing unit starts turning backwards.

3. Apply grinding paste to the rear left mowing unit with a brush.



NOTICE Apply the paste equally and over the entire length of the cutting knives.

4. Repeat until you no longer hear a grinding noise.



NOTICE Reduce the cutting clearance to get a better result.

5. Put Raising/lowering switch in the OFF position.

The mowing units will stop turning.

6. Continue with **Back lapping the front and centre mowing units**.

Back lapping the front and centre mowing units

1. Unlock the front mowing units.
2. Lower the front and centre mowing units.
3. Put Raising/lowering switch in the ON position.
4. Press the cross-cut button.

The front and centre mowing units start turning backwards.

5. Apply grinding paste to the front and centre mowing units with a brush.



NOTICE Apply the paste equally and over the entire length of the cutting knives.

6. Repeat until you no longer hear a grinding noise.



NOTICE Reduce the cutting clearance to get a better result.

7. Put Raising/lowering switch in the OFF position.

The mowing units will stop turning.

8.16 Maintaining the electrical system

8.16.1 Battery

Inspect the battery every 50 hours and clean the battery every 1500 hours or two years.

CAUTION!

Battery electrolyte contains sulphuric acid. It is poisonous and can cause serious burns.

- Wear eye protection and gloves.
- Keep skin protected.
- If electrolyte is swallowed, get medical attention immediately.
- If electrolyte is splashed into eyes, flush immediately with water for 15-30 minutes and get medical attention.
- If electrolyte is splashed onto skin, flush immediately with water and get medical attention if necessary.



The battery produces a flammable and explosive gas. The battery may explode.

- Do not smoke near the battery.
- Do not allow direct metal contact across battery posts.
- Remove negative cable first when disconnecting.
- Install negative cable last when connecting.



NOTICE Do not attempt to open the battery, add battery fluid or perform maintenance work on the battery. Any attempt to do so will invalidate the warranty.

8.16.1.1 Checking the battery

The battery is fully charged on delivery. If the machine is not used before the battery's expiry date, the battery must be fully recharged.

CAUTION!



- Charge batteries in an open, well-ventilated area away from sparks and a naked flame.
- Wear protective clothing and use insulated tools.
- Remove the battery charger's plug from the plug socket before connecting it to or disconnecting it from the battery.

Before you begin: Make sure that the battery is clean, the battery bolts are tightened and the ventilation holes aren't blocked.

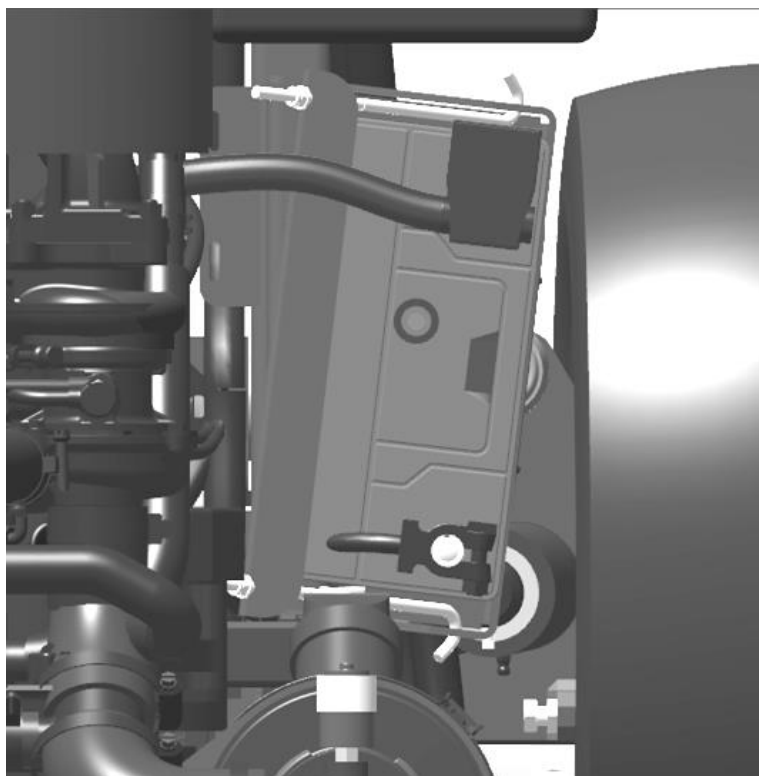

1. Check the battery indicator (1):
 - Green: battery in good working order.
 - Black: battery must be charged.
 - White: battery must be replaced.
2. If necessary, charge the battery for 1 hour with 6-10 A.

8.16.1.2 Replacing the battery

When replacing the battery, always replace it with one specified by Roberine. Contact your Roberine dealer.

Before you begin: Park the machine safely and let the engine cool down.

1. Disconnect the negative (-) battery cable.
2. Push the red cover away from the positive (+) terminal and disconnect the battery cable.
3. Disconnect the battery holder.
4. Remove the battery.
5. Place the new battery on the battery tray.
6. First connect the positive (+) cable to the positive (+) battery terminal and then the negative (-) cable to the negative (-) battery terminal.
7. Apply acid-free spray lubricant on the battery terminals to prevent corrosion.
8. Slide red cover over the positive battery terminal.
9. Install the battery holder.

8.16.1.3 Cleaning the battery terminals

Before you begin: Park the machine safely and let the engine cool down.

1. Disconnect the battery (see *Replacing the battery* on page 56).
2. Clean the terminals and the battery cable ends with a wire brush until they are bright.
3. Reconnect the battery (see *Replacing the battery* on page 56).
4. Apply acid-free spray lubricant on the terminals to prevent corrosion.

8.16.2 Replacing the light bulbs

Replace the light bulbs immediately when they are broken.



CAUTION!

- Halogen light bulbs contain gas under pressure. The bulb may shatter if the glass is scratched or dropped. Wear eye protection and handle the bulb with care when replacing.
- Do not touch the glass of the headlight bulb with bare skin or the bulb may fail prematurely. Use gloves or a cloth when inspecting or replacing the bulb.

1. Locate the headlights.

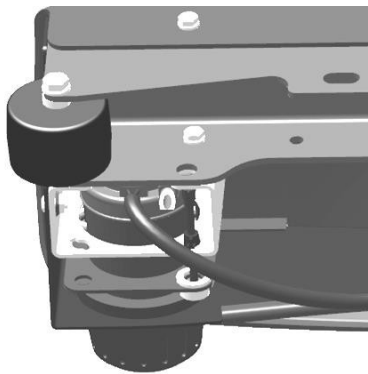



1. Remove the rubber cover.
2. Disconnect the plugs.
3. Unlock the retainer clip.
4. Replace the light bulb.
5. Connect the plugs and secure the bulb with the retainer clip.
6. Install the rubber cover.
7. Check the operation of the light bulb.

8.16.3 Replacing fuses

When replacing fuses, make sure that they have the correct specifications.

Before you begin: Locate the right fuse holder:

1. Fuse holder 1
2. Fuse holder 2

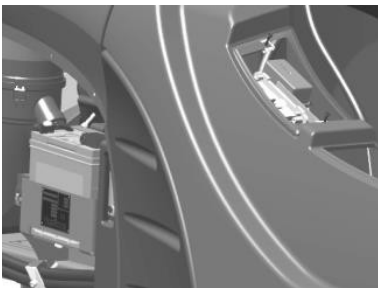

Fuse holder 1

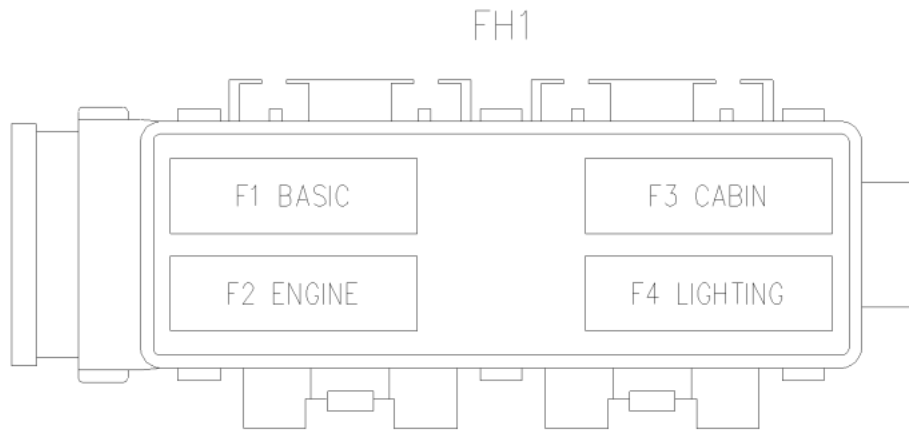

Fuse	Amperage	Description
F1	50	Main relay F6 - F21
F2	50	Pre-heating, stop valve fuel pump
F3	40	Cabin*
F4	20	Operating lights*
F4	40	Road lighting*

* = Optional

Fuse holder 2

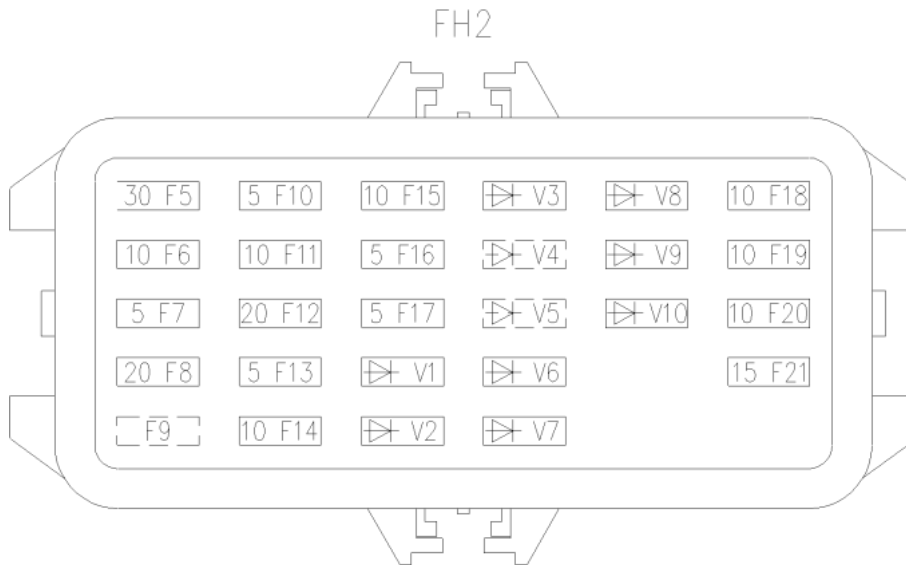

Fuse	Amperage	Description
F5	30	Stop valve fuel pump
F6	10	Power supply control unit
F7	5	Power supply control unit
F8	20	Supply outputs control unit
F9	15	
F10	5	Supply drag sensor, lifting and lowering, safety systems
F11	10	Weight transfer system, rotating light*
F12	20	Electromagnetic valves mowing
F13	5	Instrument panel
F14	10	Airseat
F15	10	12 V connection
F16	5	Seat switch
F17	5	Guidance signal flails/cage programme
F18	10	Parking light, headlights, hazard
F19	10	Indicator
F20	10	Horn
F21	15	Headlights

* = Optional

8.16.4 Replacing relays

When replacing relays, make sure that they have the correct specifications.

Before you begin: Locate the right relay holder:

1. Relay holder 1
2. Relay holder 2

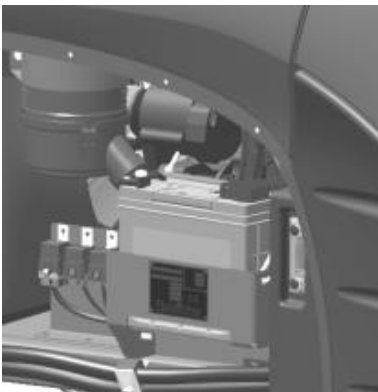

Relay holder 1

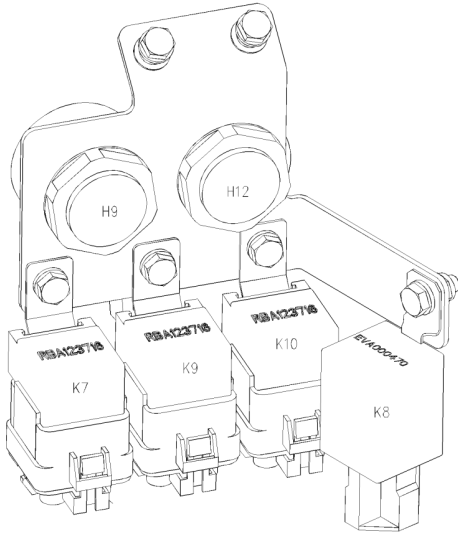

Relay	Description
K1	Main relay
K2	Start relay
K3	Pre-heat relay

Relay holder 2

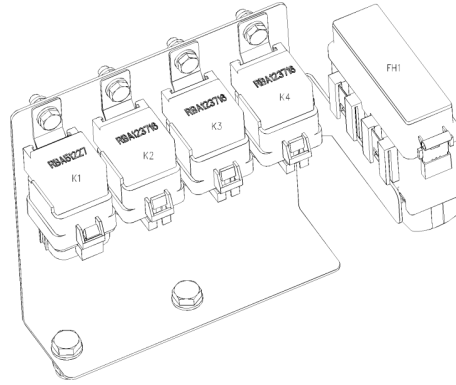

Relay	Description
K7	Switched power supply
K8	Indicator light relay
K9	Headlights relay
K10	Parking lights relay

8.17 Checking the wheel bolts

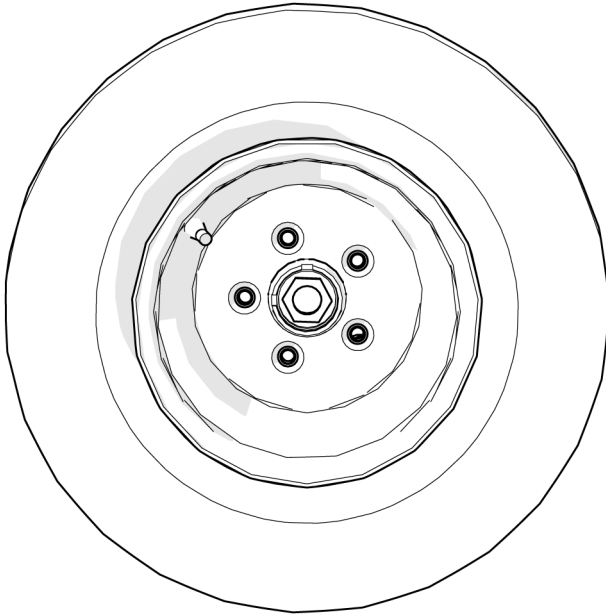

Re-tighten the wheel bolts after the first 5 hours and then every 50 hours. Tighten the wheel bolts and nuts to a torque of 140 Nm with a torque spanner.



CAUTION! Loose wheel bolts may detach from the wheels, which may cause a serious accident resulting in a serious personal injury.

8.18 Cleaning surfaces

Keeping plastic and metal surfaces clean prevents damages to the surfaces. Use a soft clean cloth (bath towel, linen cloth, car wash mitt to clean plastic surfaces. Wash plastic surface with clean water and a mild liquid automotive washing soap. Use a high-quality automotive wax regularly to maintain painted surfaces.

Do not use abrasive materials, such as polishing compounds, on plastic or metal surfaces.

8.19 Refuelling

WARNING Fuel vapours are flammable and can explode:



- Turn off the engine before refuelling.
- Do not smoke while working with fuel.
- Keep fuel away from sparks and open flames.
- Refuel outside or in a well-ventilated space.
- Immediately clean up any spilled fuel.

CAUTION! Dirt and water in the fuel tank can cause damage to the engine:



- Remove all the dust and dirt from around the opening of the fuel tank.
- Use clean, fresh, stabilised fuel.
- Use a non-metallic funnel with a plastic mesh strainer when filling the fuel tank or container

Before you begin: Park the machine safely and let the engine cool down.

1. Make sure the area around the fuel tank's cap is clean.
2. Slowly unscrew the fuel tank's cap allowing the pressure in the fuel tank to escape.
3. Fill the fuel tank to bottom of the filler neck. Do not overfill.
4. Screw the cap back on.

9 Transport and storage

9.1 Transport

The mower can be transported on a trailer.

NOTICE



- The trailer's load bearing capacity must be greater than the weight of the machine plus the weight of the mowing units (refer to *Technical specifications* on page 22).
- Make sure the trailer has all the legally required lights and indicators.

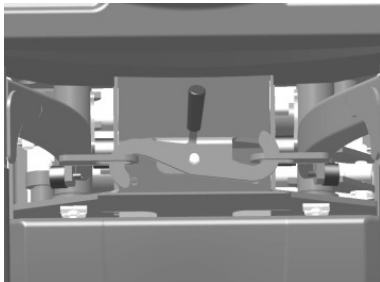

1. Raise the three mowing units and lock them in the transport position with the locking lever.
2. Drive the machine forwards onto the trailer. Make sure that:
 - the surface is horizontal;
 - the trailer is equipped with side guards;
 - you keep the wheel away from the edges.
 - the weight of machine is centred above the wheels of the trailer.
3. Park the machine safely:
 - turn off the engine;
 - remove the ignition key.
4. Secure the machine at the front with strong straps, chains or cables. Use the lashing eyes on the left-hand and right-hand sides of the machine to guide the straps downwards and outwards.
5. Secure the machine at the rear with strong straps, chains or cables. Use the brackets on both sides of the rear frame to guide the straps downwards and outwards.

CAUTION! Make sure that the securing items do not come into contact with other parts of the machine.



6. Carefully lock the mower's bonnet.

CAUTION! The bonnet may spring open if it is not properly secured. Make sure that the machine faces the front of the trailer.



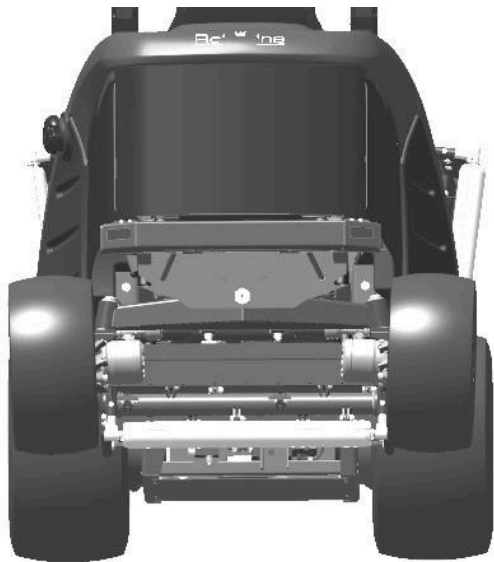

9.2 Preparing the machine for storage

Before you store the machine make sure that:

1. the machine and mowing units are free of grass and dirt.
2. you repair or replace all the worn or damaged parts.
3. you tighten any loose mounting materials.
4. you repair scratched or damaged metal surfaces, to prevent the formation of rust.
5. you wash the machine and apply wax to the relevant surfaces.
6. you run the engine for five minutes to dry the belts and pulleys.
7. you apply a thin layer of engine oil to all the rotating points and the wear points, to prevent the formation of rust.
8. you lubricate the grease nipples and check the tyre pressure.

CAUTION! Fuel vapours are flammable and can explode. The exhaust gases from the engine contain carbon monoxide and can cause serious injury or even death. Make sure that:



- you do not run the engine for longer than is absolutely necessary to drive the machine into or out of the storage location.
- you let the engine cool down before entering the storage location.
- you remove all dirt around the engine and the exhaust muffler.
- you store the machine at a safe distance from flammable materials.
- you do not store the machine in a building where any fuel vapours can come into contact with sparks or an open flame.

9.3 Preparing the fuel and engine for storage

Fuel:

1. Fill up the tank completely with fuel.



NOTICE Filling the fuel tank reduces the volume of air in the tank, which slows down the deterioration of the fuel quality.

2. Park the machine in a safe, well-ventilated location.

Engine:

The storage procedure for the engine must be observed if the machine is not going to be used for more than 60 days.

1. Change the engine oil and replace the oil filter while the engine is still hot.
2. If necessary, service the air filter.
3. Remove dirt from the engine air intake grill.
4. Clean the engine and the engine compartment.
5. Remove the battery (see *Replacing the battery* on page 56).
6. Clean the battery terminals (see *Cleaning the battery terminals* on page 56). Check the electrolyte level if the battery is not maintenance-free.
7. Store the battery in a cool, dry, frost-free location.



NOTICE A stored battery must be recharged every 30 days.

8. Recharge the battery.
9. Store the machine in a dry, protected location. If the machine is stored outdoors, cover it with a watertight cover.



NOTICE For more detailed information about engine storage, see your Yanmar Engine Manual.

10 Recommissioning

When taking the machine out of storage:

1. Check the engine oil level (see *Checking the engine oil level* on page 42).
2. Check the electrolyte level if the battery is not maintenance-free. If necessary, recharge the battery (see *Checking the battery* on page 55).
3. Reinstall the battery (see *Replacing the battery* on page 56).
4. Lubricate all the lubrication points (see *Lubrication* on page 40).
5. Run the engine for five minutes without turning on the mowing units to properly distribute the oil through the engine.
6. Make sure all the covers, screens and deflectors are fitted.

10.1 Safety checks

Check the safety system to see if the electronic safety lock circuit works correctly, see *Testing the safety system* on page 26.

1. Test the mowing switch.
2. Test the parking brake.
3. Test the seat mechanism.
4. Test the neutral position (if applicable).
5. Test the parking brake.
6. Test the raise/lower switch.

10.2 Tyre checks

1. Check the tyres for damage.
2. Check the tyre pressure with an accurate pressure gauge (see *Technical specifications* on page 22).

11 Troubleshooting

11.1 Safety problems

The SOS (Sitting on Seat) system checks whether the system functions are correctly configured for the machine to start. If this is not the case, a text message will appear on the display. The following text messages may appear:

Message	Cause
Activate parking brake to start	The parking brake is not applied.
Turn off mow switch to start	The mowing switch is in the mowing position.
Turn off backlap switch to start	The mowing switch is in the backlapping position.
Turn off towing to start	The ball valve is in the towing position.



NOTICE Contact your Roberine dealer if there is a different problem.

11.2 Engine problems

Problem	Possible cause	Solution
The engine performs badly.	There is dirt in the fuel system or the fuel is old.	Change the fuel for new, stabilised fuel. Purchase the new fuel from a different fuel supplier before deciding whether there is something wrong with the machine. Suppliers mix their fuels in different ways and fuel from a different fuel supplier usually solves performance problems.
The engine does not start.	The seat switch is faulty.	Contact your Roberine dealer.
	The foot pedals are not in the neutral position.	Place the foot pedals in the neutral position.
	The mowing switch is not in the neutral position	Put the mowing switch in neutral.
	The parking brake is not applied.	Apply the parking brake.
	The battery charge is too low	Charge the battery.
	The battery is sulphated or worn.	Replace the battery.
	The battery cables are loose or corroded.	Clean and tighten the battery clamps.
	A fuse has blown.	Replace the fuse. See <i>Replacing fuses</i> on page 59
	The fuel level is too low.	Refill the fuel tank.
	The fuel filter is blocked.	Replace the fuel filter.
	The wrong type of fuel is used.	Replace the fuel.
	The electrical connections are dirty.	Check and clean the connectors.
	The tank bleed opening is blocked.	Clean the air breather.
The oil level is too high.	Drain the excess oil.	
The injectors are faulty.	Test the injectors.	
The engine is difficult to start.	The fuel supply pipes or fuel filters are blocked.	Clean the fuel system.

Problem	Possible cause	Solution
The engine overheats.	The air filter is dirty.	Clean the air filter. See <i>Cleaning the air intake grill and engine cooler</i> on page 44.
	There are air bubbles in the fuel line.	Bleed the fuel system.
	The fuel is contaminated.	Replace the fuel and bleed the fuel system.
	The coolant level is too low.	Replenish the coolant fluid. See <i>Cooling system</i> on page 45.
	The cooling system is dirty.	Rinse the cooling system.
	The overflow tank cap is faulty.	Replace the overflow tank cap.
	The thermostat is faulty.	Contact your Roberine dealer.
	The water temperature indicator or transmitter is faulty.	Contact your Roberine dealer.
	The engine oil level is too low.	Replenish the engine oil.
	The V-belt is loose or faulty.	Tighten or replace the V-belt. See <i>V-belt</i> on page 48.
	The idling speed is too low.	Increase the idling speed.
	The grill, radiator screen or radiator fins are dirty.	Clean the grill, radiator screen and the radiator.
	The driving speed is too fast for the circumstances.	Drive slower.
The engine knocks.	The V-belt is broken.	Replace the V-belt. See <i>V-belt</i> on page 48.
	The engine oil level is too low.	Replenish the engine oil.
	The wrong type of fuel is used.	Replace the fuel.
	The injectors are faulty.	Test the injectors.
	There is water in the fuel system.	Replace the fuel and bleed the fuel system.
The engine runs erratically or stalls.	The engine has overheated.	Clean the radiator and covering panels.
	The fuel filter is blocked.	Replace the fuel filter.
	The air intake system is blocked.	Clean the air intake system. See <i>Cleaning the air intake grill and engine cooler</i> on page 44.
	The bleed hole in the fuel cap is dirty.	
	The seat switch is faulty.	Contact your Roberine dealer.
	Old fuel or the wrong type of fuel is used.	Replace the fuel.
	The fuel level is too low.	Refill the fuel tank.
	The injectors are faulty.	Test the injectors.

Problem	Possible cause	Solution	
The engine makes irregular combustion noises.	The fuel level is too low.	Refill the fuel tank.	
	There is water in the fuel system.	Replace the fuel and bleed the fuel system.	
The engine rotations are irregular.	There is water in the fuel system.	Replace the fuel and bleed the fuel system.	
The engine stalls when loaded.	The fuel is contaminated.	Replace the fuel and bleed the fuel system.	
	The air filter is dirty.	Clean the air filter. See <i>Cleaning the air intake grill and engine cooler</i> on page 44.	
	The fuel filter is blocked.	Replace the fuel filter.	
The engine will not run at a low speed	The fuel is contaminated.	Replace the fuel and bleed the fuel system.	
	The fuel filter is dirty.	Replace the fuel filter.	
	The throttle cable is loose.	Connect the throttle cable.	
The engine has no power.	The wrong type of fuel is used.	Replace the fuel.	
	The fuel is contaminated.	Replace the fuel and bleed the fuel system.	
	The fuel filter is dirty.	Replace the fuel filter.	
	The fuel filter is blocked.	Replace the fuel filter.	
	The air intake system is blocked.	Clean the air intake system. See <i>Cleaning the air intake grill and engine cooler</i> on page 44.	
	The engine has overheated.	Clean the radiator and covering panels.	
	The driving speed is too fast for the circumstances.	Drive slower.	
	The oil level is too high.	Drain the excess oil.	
	The balance is incorrect.	Adjust the balance.	
	The engine is overloaded.	Reduce the load.	
	The viscosity of the engine oil is too high.	Use a different type of engine oil. See <i>Technical specifications</i> on page 22 for the correct type of engine oil.	
	Engine runs irregularly.	The fuel is contaminated.	Replace the fuel and bleed the fuel system.
		The air filter is dirty.	Clean the air filter. See <i>Cleaning the air intake grill and engine cooler</i> on page 44.
The electrical connections are dirty or corroded.		Clean and tighten the electrical connections.	
The engine has overheated.		Clean the radiator and covering panels.	
The oil pressure is low.	The engine oil level is too low.	Replenish the engine oil.	

Problem	Possible cause	Solution
The engine uses too much oil.	The oil filter is blocked.	Replace the oil filter.
	The wrong type of engine oil is used.	Use a different type of engine oil. See <i>Technical specifications</i> on page 22.
	There is an oil leak.	Find and repair the oil leaks.
	There is an oil leak.	Find and repair the oil leaks.
	The wrong type of engine oil is used.	Use a different type of engine oil. See <i>Technical specifications</i> on page 22.
	The oil filter is blocked.	Replace the oil filter.
The engine produces white smoke.	The air intake system is blocked.	Clean the air intake system. See <i>Cleaning the air intake grill and engine cooler</i> on page 44.
	The wrong type of engine oil is used.	Use a different type of engine oil. See <i>Technical specifications</i> on page 22.
The engine produces black or grey smoke	The engine temperature is low.	
	The wrong type of fuel is used.	Replace the fuel.
High fuel consumption.	The air intake system is blocked.	Clean the air intake system. See <i>Cleaning the air intake grill and engine cooler</i> on page 44.
	The driving speed is too fast for the circumstances.	Drive slower.
	The wrong type of fuel is used.	Replace the fuel.
	The air intake system is blocked.	Clean the air intake system. See <i>Cleaning the air intake grill and engine cooler</i> on page 44.
	The driving speed is too fast for the circumstances.	Drive slower.
	The engine temperature is low.	
	The mowing units are set incorrectly.	Adjust the mowing units. See <i>Operating the mowing units</i> on page 31

11.3 Electrical problems

Problem	Possible cause	Solution
The battery does not charge	The connections are loose or corroded.	Clean and tighten the battery clamps.
	The battery contains a dead cell.	Replace the battery.
	The V-belt is loose or faulty.	Check the V-belt. See <i>V-belt</i> on page 48.
	The alternator is faulty.	Check the V-belt. See <i>V-belt</i> on page 48.
The battery warning light remains lit when the engine is running.	The engine speed is too low.	Increase the engine speed.
	The battery is faulty.	Replace the battery. See <i>Replacing the battery</i> on page 56.

Problem	Possible cause	Solution
The starter motor does not work.	The V-belt is loose or faulty.	Check the V-belt. See <i>V-belt</i> on page 48.
	The alternator is faulty.	Check the V-belt. See <i>V-belt</i> on page 48.
	The battery connections are loose or corroded.	Clean and tighten the battery clamps.
	A fuse has blown and battery is discharged.	Replace the fuse. See <i>Replacing fuses</i> on page 59 and charge the battery.
	The parking brake is in the OFF position.	Put the parking brake in the ON position.
	The seat switch is faulty.	Contact your Roberine dealer.
The starter motor starts slowly.	The foot pedals are not in the neutral position.	Place the foot pedals in neutral.
	The mowing switch is not in the neutral position	Put the mowing switch in neutral.
	The battery voltage is low.	Charge the battery.
One light circuit does not work.	The viscosity of the engine oil is too high.	Use a different type of engine oil. See <i>Technical specifications</i> on page 22 for the correct type of engine oil.
	The battery connections are loose or corroded.	Clean and tighten the battery clamps.
	A fuse has blown.	Replace the fuse. See <i>Replacing fuses</i> on page 59.

11.4 Vehicle problems

Problem	Possible cause	Solution
The engine vibrates too much	The engine speed is too low.	Increase the engine speed.
The engine runs but the machine does not move.	The parking brake is applied.	Release the parking brake.
	The transmission oil level is too low.	Top off the transmission oil. See <i>Transmission and hydraulic oil</i> on page 49.
	The transmission is cold.	Allow the engine to warm up.

11.5 Steering problems

Problem	Possible cause	Solution
The steering does not work	The tyres are not at the correct pressure.	Check the tyre pressure. See <i>Technical specifications</i> on page 22.
	The steering couplings are dry.	Lubricate the steering couplings. See <i>Lubrication</i> on page 40.
	The hydraulic oil level is too low.	Top off the hydraulic oil. See <i>Transmission and hydraulic oil</i> on page 49.

11.6 Hydraulic problems

Problem	Possible cause	Solution
The hydraulic system does not work.	The hydraulic oil level is too low.	Replenish the hydraulic oil. See <i>Transmission and hydraulic oil</i> on page 49.
	The relief valve is faulty.	Contact your Roberine dealer.
	The pump or motor is faulty.	Contact your Roberine dealer.
The hydraulic pump is noisy.	The suction line is blocked.	Check the tank filter.
	The oil level is too low.	Replenish the hydraulic oil. See <i>Transmission and hydraulic oil</i> on page 49.
	The wrong type of hydraulic oil is used.	Use a different type of hydraulic oil. See <i>Technical specifications</i> on page 22.
The oil foams.	There is an air leak.	Tighten the connections and make sure that the O-rings are undamaged.
	The oil level is too low.	Replenish the hydraulic oil. See <i>Transmission and hydraulic oil</i> on page 49.
	The wrong type of hydraulic oil is used.	Use a different type of hydraulic oil. See <i>Technical specifications</i> on page 22.
The cutting blades rotate slowly	There is an air leak.	Tighten the connections and make sure that the O-rings are undamaged.
	The oil level is too low.	Replenish the hydraulic oil. See <i>Transmission and hydraulic oil</i> on page 49.
	The wrong type of hydraulic oil is used.	Use a different type of hydraulic oil. See <i>Technical specifications</i> on page 22.
The oil overheats.	The relief valve is faulty.	Contact your Roberine dealer.
	The oil level is too low.	Refill the hydraulic oil. See <i>Transmission and hydraulic oil</i> on page 49.
	The wrong type of hydraulic oil is used.	Use a different type of hydraulic oil. See <i>Technical specifications</i> on page 22.
	There is an internal high pressure leak.	Contact your Roberine dealer.
	The weight transfer valve has been closed with too much weight.	Put the weight transfer switch in the ON position.
	The oil cooler is blocked.	Clean the oil cooler.
	The outdoor temperature is high and the hydraulic system is subjected to a heavy load.	Contact your Roberine dealer.

11.7 Driving problems

Problem	Possible cause	Solution
The machine cannot be driven forwards or backwards.	The hydraulic oil level is too low.	Replenish the hydraulic oil. See <i>Transmission and hydraulic oil</i> on page 49.
	The wrong type of hydraulic oil is used.	Use a different type of hydraulic oil. See <i>Technical specifications</i> on page 22 for the correct type of oil.
	The parking brake is applied.	Release the parking brake.
	The hydraulic pump has internal damage.	Contact your Roberine dealer.
The machine accelerates slowly	The hydraulic oil level is too low.	Replenish the hydraulic oil. See <i>Transmission and hydraulic oil</i> on page 49.
	There is air in the hydraulic system.	Bleed the hydraulic system or contact your Roberine dealer.
	The parking brake is stuck.	Contact your Roberine dealer.
	The engine speed is too low.	Increase the engine speed.

11.8 Mowing units problems

Problem	Possible cause	Solution
The mowing result is poor.	The machine is driven too fast.	Drive at a slower speed.
	The engine speed is too low.	Increase the engine speed.
The terrain is uneven or rolling.	The machine is driven too fast.	Drive at a slower speed.
	The rotor speed is too low.	Increase the rotor speed.
The rollers collect grass.	The scraper is set incorrectly.	Check and adjust the scraper.
The mowing units cannot be raised/ lowered	There is not enough hydraulic oil in the reservoir.	Replenish the hydraulic oil. See <i>Transmission and hydraulic oil</i> on page 49.
	The engine speed is too low.	Increase the engine speed.
The mowing units do not rotate.	There is not enough hydraulic oil in the reservoir.	Check the hydraulic oil level and refill if necessary. See <i>Transmission and hydraulic oil</i> on page 49.
	The proximity switch is out of range.	Contact your Roberine dealer.
	The wiring is broken or short-circuited.	Contact your Roberine dealer.

12 Warranty conditions

The warranty is granted by Roberine for a period of 24 months or 1500 hours whichever occurs first from the date of delivery of the machine.

The warranty covers the repair and/or replacement of parts that become defective during the warranty period as a consequence of a hidden defect of the machine. In the event of repair or replacement, the warranty will not be extended.

Repairs and replacement of defective components that are necessary as a result of normal wear and tear during use of the machine are not covered by the warranty.

Parts that require replacement at regular service intervals are not covered by the warranty.

Also excluded from warranty coverage are defects resulting from deliberate damage, failure to comply with the instructions provided in this manual, operating errors or repairs which are not performed by Roberine or on behalf of Roberine.

Warranty repairs must be carried out by your local authorised Roberine dealer with the use of original Roberine parts.

Costs such as lost income, travel costs, installation costs, shipping costs, etc. are not covered by the warranty and will not be reimbursed.

Any situations not covered by the preceding provisions shall be subject to the most recently published General Terms and Conditions of Delivery for the Metal Industry (Metaalunie conditions).



NOTICE Roberine is **not** liable for any direct or indirect damage as a result of operating errors, lack of expert maintenance or any use other than described in this manual. The liability of Roberine also lapses in the event that you or a third party performs work, such as the installation of additional equipment, on the machine or accessories without the permission of Roberine.

13 Appendices

13.1 Statement of Conformity

Your mower complies with all legal requirements about integrated safety stated by the European Machinery Directive. We are therefore authorised to give the following CE declaration for your machine:



The CE-type plate on your machine and the following *statement of conformity* mean that the manufacturer complied with the “principles of safety integration” according the Machinery Directive.

This means:

1. excluding or diminishing the risks when designing the product;
2. taking the necessary safety measure for risks that cannot be excluded; and
3. informing the user (by means of this manual and safety signs) about the remaining risks.

EG declaration of conformity

CONFORM APPENDIX II SUB A OF DIRECTIVE 2006/42/EG

We,

Roberine
Goolkatenweg 65
7521 BE, Enschede
The Netherlands

declare under our full responsibility that the machinery:

Make:	Roberine
Type:	mower
Model:	F3 and R3
Serial number:	See constructor's plate
Designation:	Tool carrier with flail mowing units (F3), resp. with reel mowing units (R3).

to which this declaration corresponds, fulfils all the relevant provisions of the directives:

Machinery Directive 2006/42/EU
EMC-Directive 2014/30/EU

and is in conformity with the following standard(s) or other normative document(s):

NEN 5509 User manuals

Signed:

NL-Giessen, may 2021

Roberine

A.G.J. van Hooff
Business unit manager

13.2 Dimensions

Front view

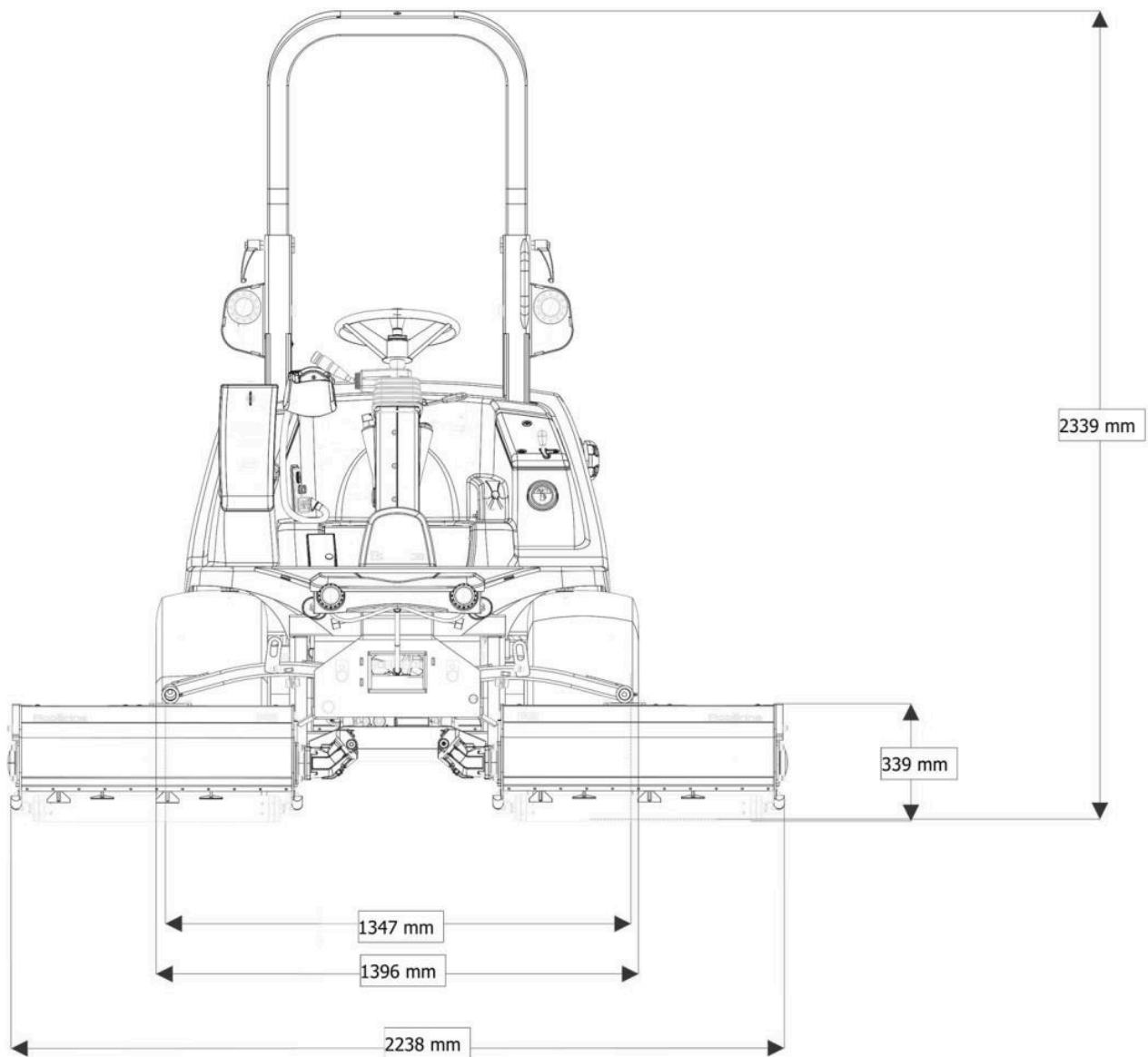

Side view

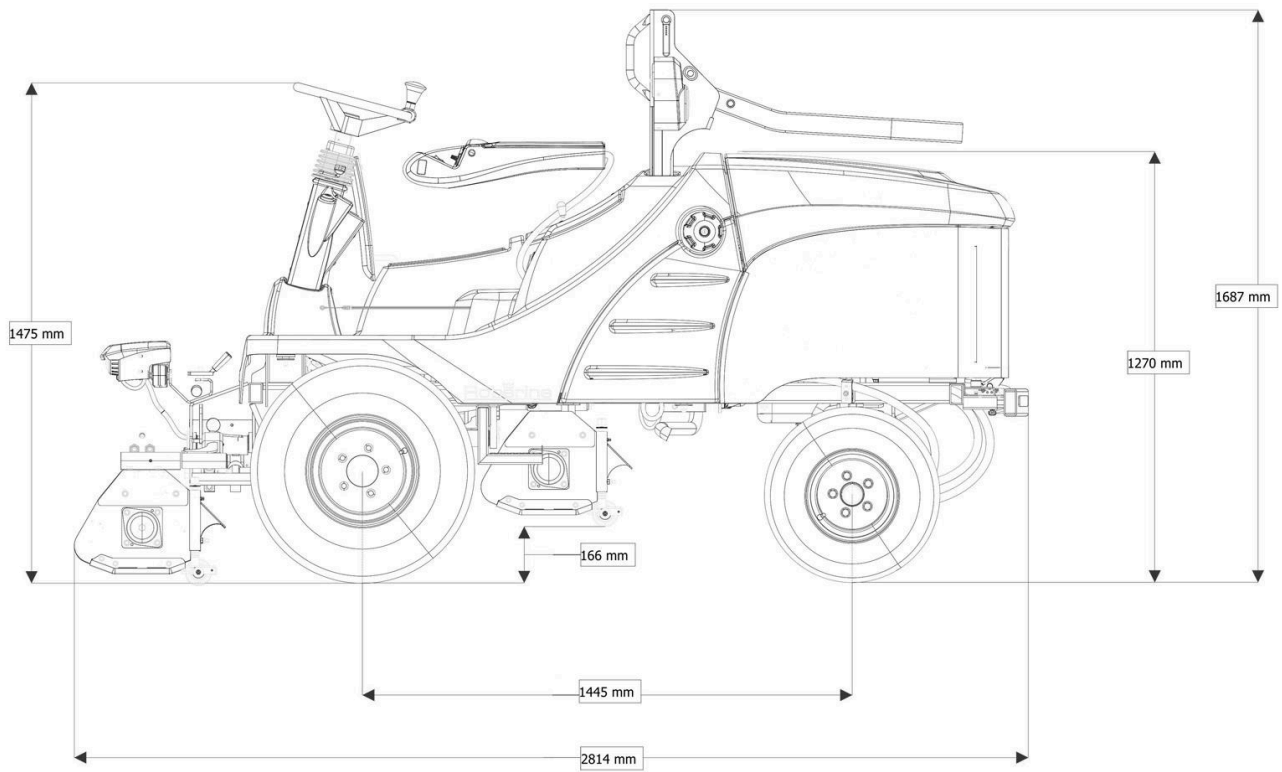

Roberine

Goolkatenweg 65
7521 BE
The Netherlands
+31 (0)534 838383
roberine.com
info@roberine.com