

# Spearhead

## Excel 323 & Twiga 3000 Reach Mowers



**HANDBOOK**

# Spearhead

## Excel 323 & Twiga 3000

### Compact Reach Mower

#### Handbook

5<sup>th</sup> Edition – October 2008

Please ensure that this manual is handed to the operator before using the machine for the first time. The operator must fully understand the contents of this manual before using this machine.

(If the machine is resold the Manual must be given to the new owner.)

#### **Important Note**

The information contained in this manual is correct at the time of publication. However, in the course of constant development, changes in specification are inevitable. Should you find the information given in this book different to the Machine it relates to please contact the "After Sales Department" for advice

Spearhead Machinery  
Green View  
Salford Priors  
Evesham  
Worcestershire  
WR11 8SW  
Tel: 01789 491860  
Fax: 01789 778683  
[www.spearheadmachinery.com](http://www.spearheadmachinery.com)  
[enquiries@spearheadmachinery.com](mailto:enquiries@spearheadmachinery.com)

# Excel 323 Reach Mower

---

© Spearhead Machinery Limited 2004

## **CE Declaration of Conformity, Conforming to EU Machinery Directive 2006/42/EC**

We, Spearhead Machinery Ltd, Green View, Salford Priors, Evesham,  
Worcestershire, WR11 8SW hereby declare that:

**Product** .....

**Product Code**.....

**Serial No**.....

**Type**.....

Manufactured by: Alamo Manufacturing Services (UK) Limited, Station Road, Salford  
Priors, Evesham, Worcestershire, WR11 8SW

Complies with the required provisions of the Machinery Directive 2006/42/EC. The  
Machinery Directive is supported by the following harmonized standards:

- BS EN ISO 14121-1 (2007) Safety of Machinery – Risk Assessment, Part 1:  
Principles Part 2: Practical Guide and Examples of Methods.
- BS EN ISO 12100-1 (2010) Safety of Machinery – Part 1: Basic Terminology  
and Methodology Part 2: Technical Principles.
- BS EN 349 (1993) + A1 (2008) Safety of Machinery – Minimum Distances to  
avoid the Entrapment of Human Body Parts.
- BS EN 953 (1998) Safety of Machinery – Guards General Requirements for the  
Design and Construction of Fixed and Movable Guards.
- BS EN 982 (1996) + A1 (2008) Safety Requirements for Fluid Power Systems  
and their Components. Hydraulics.

The EC Declaration only applies if the machine stated above is used in accordance  
with the operating instructions.

**Signed**



(On behalf of Spearhead Machinery Ltd)

**Status**

General Manager

# Excel 323 Reach Mower

---

**Date** .....

## **Contents**

Specification	5
Safety	6
Safety Stickers	9

## **Installing your Machine**

Introduction	10
Tractor Requirements	10
Attaching To The Tractor	11
Running Up Your Machine	16
Removing From The Tractor	17
Layout Of Controls In The Cab	18
Reach Mower Set-Up	19
Warnings	22
Engaging & Disengaging Head Drive	23
Transport To Work Position	24
Moving Into Transport Position	25
Cutting Sequence	26
Break Back	26
Wire Trap	27
High Voltage Cables	27

## **Optional**

Debris Blower	28
Oil Cooler	28

## **Servicing & Maintenance**

Lubrication Chart	29
Torque Settings	30
Hydraulic Hoses	31
Oil Supply	32
Filtration Maintenance	32
Flail Head	33
Pins & Bushes	34
Pump & Motor Failure	35

<b>Warranty Conditions</b>	<b>36</b>
----------------------------	-----------

# Excel 323 Reach Mower

## Specification

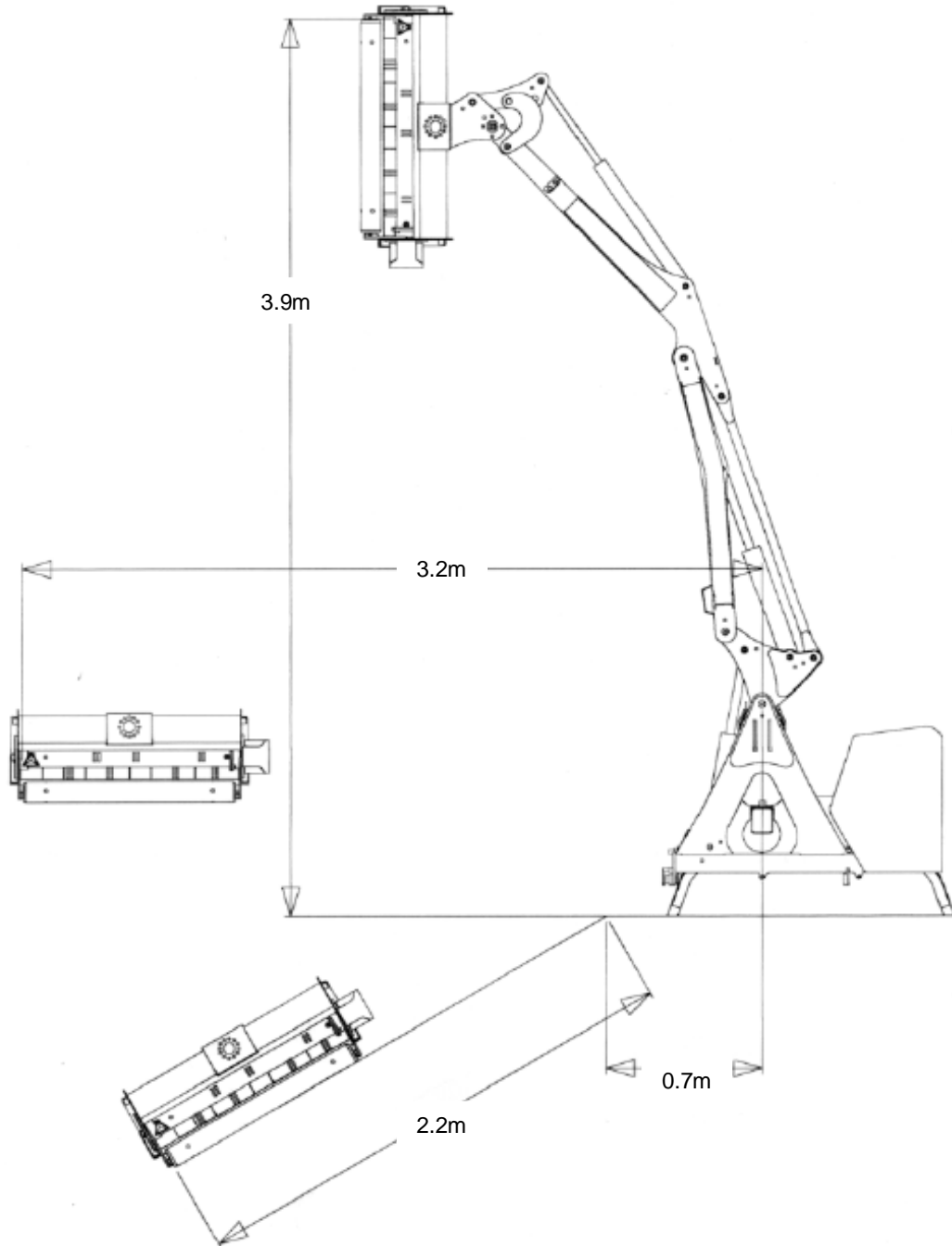

	Excel 323
Weight including oil (kg)	495
Tractor (hp)	25 - 40
Minimum tractor weight (kg)	1250
Oil tank capacity (lt/min)	70



## Safety

### **Safety Recommendations**

Beware of the following Potential Dangers associated with the use of this machine:

- Becoming trapped when hitching or unhitching
- Tractor overbalancing when arm is extended
- Electrocutation due to hitting overhead power lines
- Getting caught on rotating power take off (PTO)
- Being hit or caught by any moving part, e.g. belts, pulleys, arms, cutting head
- Being hit by flying debris or machine parts due to machine damage
- Machine overbalancing when not in use
- Injection of high pressure oil from damaged couplings or hydraulic hoses
- Accidents due to collision with other machines, or debris left on road

#### **Always**

- Ensure the operator has read this handbook and has been trained to use the machine.
- Ensure all cab safety guards are in place and all tractor windows closed.
- Before leaving the tractor cab always ensure that the flail head is firmly on the ground, no weight is on the machine's hydraulics and the rotor has stopped spinning.
- Check that all guards are properly fitted and there are no damaged or loose parts. Particular attention should be given to the flails to ensure they are not damaged, cracked or missing.
- Inspect work area for wire, steel posts, large stones and other dangerous materials and remove before starting work.
- Beware of the danger of overhead power cables. The operator must be aware of the maximum height and reach of the machine when working under power cables. The minimum legal height for 11,000 and 22,000-volt cables is 5.2 metres from the ground. When fully extended, the machine may well exceed this height so extreme caution should be practised. For more information contact the Health and Safety Executive or your local power company.
- Ensure that all warning labels are always visible and that they are not damaged, defaced or missing.
- Lower the head to the ground when parking up
- Fit locking pins to slew and height before transport and before unhitching when applicable.
- Wear ear defenders if operating without a quiet cab or with the cab windows open.
- Ensure tractor guards are fitted correctly and are undamaged
- Work at a safe speed, taking into account terrain, passing vehicles and obstacles

# Excel 323 Reach Mower

---

- Ensure that the tractor meets the minimum weight recommendations of the machine manufacturer and that ballast is used if necessary
- Check that machine fittings and couplings are in good condition
- Follow the manufacturer's instructions for attachment and removal of machine from the tractor are warning signs to alert others to the type of machine working in the vicinity. Signs should be placed at both ends of the work site and should be in accordance with Department of Transport recommendations.
- Ensure flails are of the type recommended by the manufacturer, are securely fitted and are undamaged.
- Ensure hydraulic pipes are correctly routed to avoid damage from chafing, stretching, pinching or kinking.
- Disengage the machine, stop the engine and remove the key before leaving the tractor cab for any reason.
- Clean up any debris left at the work site.
- Ensure that when you remove the machine from the tractor it is secured in a safe position using the stands provided.

## Never

- Never operate the machine with other people present, as it is possible for debris, including stones, to be discharged from the front and rear of the flail head.
- Never operate the machine until you have read and understood the relevant Handbook and are familiar with the controls.
- Never use a machine that is poorly maintained or has guards that are damaged or missing
- Never allow an inexperienced person to operate the machine without supervision.
- Never use or fit a machine onto a tractor if it doesn't meet the manufacturer's specification.
- Never use a machine if the hydraulic system shows signs of damage.
- Never attempt to detect a hydraulic leak with your hand, use a piece of card.
- Never allow children to play on or around the machine at any time.
- Never attempt any maintenance or adjustment without first disengaging the PTO, lowering the head to the ground, stopping the tractor engine and applying the tractor parking brake.
- Never leave the cab without removing the ignition key.
- Never operate the tractor or any controls from any position other than from the driving seat.
- Never stop the engine with the PTO engaged.
- Never operate with flails missing.
- Never operate PTO **above** recommended speed, 540 R.P.M. flail head, 150 R.P.M. cutter-bar.
- Never operate with wire around the rotor. Stop immediately.
- Never use the head at an angle, which may throw debris towards the cab.
- Never attempt to use the machine for any purpose other than that it was designed for.
- Never transport with the PTO engaged
- Never enter the working area of the machine (risk of injury!)
- Never transport with the controls live, always turn off electrical isolator switch (red) and disconnect supply.



# Excel 323 Reach Mower

---

## Warning Signs

You are advised to display clear warning signs to indicate the type of machine when working in public places. The signs should be carefully placed at either end of the work site to give advanced warning of the hazard.

Contact your local Highways Authority or Department of Transport for more information.

### Roadwork Guidelines:

On two-way roads, one set of signs should face the traffic in each direction.

Work should be within 1 mile of the signs.

Work only when visibility is good and at times of low risk, e.g. NOT during rush hour.

Vehicles should show an amber flashing light.

Vehicles should be conspicuously coloured.

Debris should be removed from the road or path at regular intervals and the operator should wear high visibility clothing.

Collect all warning signs promptly when the job is finished.

## Training

It is the responsibility of the Spearhead dealer to provide instruction on the safe installation, operation and maintenance of the machine in the first instance. Further training is available from Spearhead Machinery Ltd on request, at cost.

## Lifting Point





# Excel 323 Reach Mower

## Safety Stickers



**Warning**  
Stay clear of mower blade as long as engine is running.



**Warning**  
Danger – flying objects keep safe distance from the machine as long as the engine is running.



**Warning**  
Stay clear of mower blade as long as engine is running.



**Warning**  
Beware of overhead electrical power line.



**Warning**  
Shut off engine and remove key before performing maintenance or repair work.



**Warning**  
Beware of escaping fluid.



**Warning**  
Carefully read operator's manual before handling this machine. Observe instructions and safety rules when operating.

**Warning**  
Check all nuts are tight every 8 hours.



# Excel 323 Reach Mower

---

## Introduction

The Excel is a very robust high capacity reach mower that is easy to operate and maintain. Ideally suited to compact tractors engaged in the task of maintenance mowing of green vegetation and annual hedge trimming. To ensure trouble-free operation this manual should be carefully studied

The term Left and Right hand applies to the machine when coupled to the tractor and viewed from the rear, this also applies to the tractor.

## Tractor Requirements

- Check your Tractor size and minimum weight on the Specification table
- Before hitching, ensure position control is selected. Do not attempt to hitch in draft control.
- Set wheel width as wide as possible.
- Ballast weight is to be fitted within tractor manufacturer's recommended requirements
- Check chains and stabilisers must be in good working order to hold the machine firmly. Do not operate without checking chains and stabilisers are tight.
- Spearhead particularly recommend 'turn buckle' type stabiliser.
- Set linkage lift rods to an equal length
- Certain machines require a 12V fused electric supply that is controlled by the tractor's ignition key.
- Spearhead particularly recommend "Category 1" three point linkage of ball end type, we do not advise the use of claw type hitching. The quick release latches should be checked, if worn or insecure they may cause accidental damage or personal injury if the machine becomes detached.
- Ensure tractor link arms can be isolated from accidental lifting.

# Excel 323 Reach Mower

## Attaching to the Tractor



### WARNING

It is most important the operator fully understands the procedure for Attaching/unattaching the reach mower to/from the tractor. The following text must be fully understood before attempting to attach the machine. If there is any doubt please contact your supplying dealer or Spearhead Service Department. Failure to follow the correct procedure to attach/ machine could result in personal injury or machine damage. Any resulting damage to a machine is not covered by warranty.

Always be sure to select a level firm surface, such as concrete before attaching to the tractor.

When operating the tractor or machine's controls do so only when seated in the tractor cab. Do not allow anyone to stand on or amongst linkage for any reason.



1



Reverse tractor

Attach lower link arms and chain stabiliser bracket by inserting lower linkage pins into the bottom set of holes. (Chains superseded with longer adjustable bars).

# Excel 323 Reach Mower

2

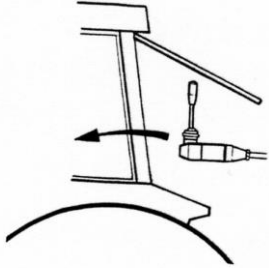

Fit control unit to cab - recommend mounting the control unit to the head side of the tractor. Modification and additional bracket may need to be fabricated. Consult your local dealer for advice.

An electric 12 volt supply cable will be needed from a fused source which is controlled by the tractor's ignition key for the machine electric controls.

3



Fit top link to machine and the tractor.

Complete with chain stabiliser brackets  
(Chains superseded with longer adjustable bars)

4



Lift the machine up on the tractor's hydraulics until both P.T.O. stub shafts are approximately in line. P.T.O. angle may vary between tractor makes. Up to 17° above horizontal is acceptable.

Ensure there is enough ground clearance below the frame.

# Excel 323 Reach Mower



5

Correct top link length until the main frame is vertical.

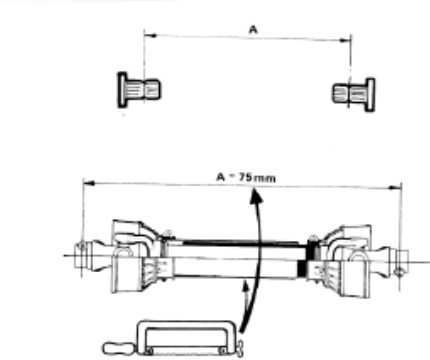

6

If fitting the P.T.O. shaft for the first time, measure and cut to the correct length.



7

Fit the P.T.O. shaft by connecting the tractor output shaft to the machine input shaft.



**Warning**

Always stop the engine  
And ensure the P.T.O.  
Drive is disengaged  
Before fitting the P.T.O.

# Excel 323 Reach Mower

8

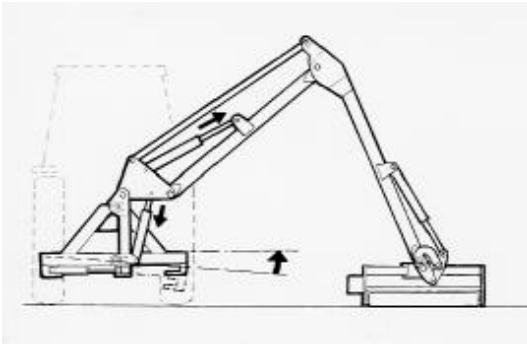

Operate the main arm to bring the frame horizontal by applying the head weight to the ground.

9

Check the machine is at the correct height and level; ensure both stabilisers are at an equal length.

Once the stabilising bars are correctly fitted, lower the tractor hydraulics allowing all the weight of the machine to be carried by the stabiliser bars.

10



### **Warning**

Fully tighten check chains  
And linkage stabilisers to  
Hold the machine rigid.

There must be no sideways  
movement, it is dangerous.

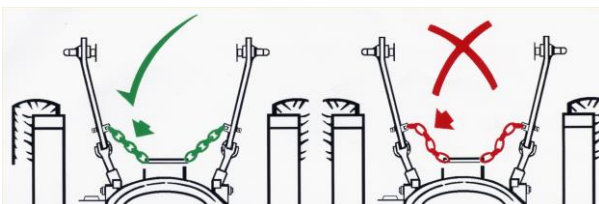

# Excel 323 Reach Mower

---

11

Fold up parking stands and store safely. The machine cannot be unhitched without these stands down.

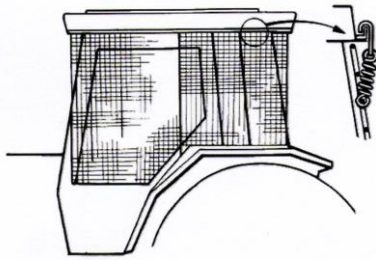

12 Operator's guard – Use only tractors with safety glass windows. If the windows are not laminated safety glass, polycarbonate glazing must be fitted between operator and cab meshing.

Shape mesh to cover all windows that the driver will look through to view flail head in any operating position. Meshing can be retained by springs and clips supplied, but it is the operators responsibility to ensure guarding is firmly in place.



## Running Up Your Machine

1. First ensure the rotor is in the 'off' position and P.T.O. drive is disengaged, and then start the tractor.
2. Engage P.T.O. into gear and run machine up to half revs allowing oil to circulate for about 5 minutes before operating arms.
3. Re-check oil level, - check for oil leaks
4. Operate the arms through the full amount of travel, check all movements are functioning correctly.
5. Place flail head near ground in a safe position and with tractor revs low idle, select 'start' position for the flail motor.
6. Once rotor is settled, slowly increase revs of P.T.O. to 540r.p.m. and run for a further 5 minutes. Slowly reduce revs and then disengage P.T.O.
7. Check all hoses for kinks, pinching, chafing and leaks.
8. Re-check oil level.



### **Warning**

The rotor will take a long time to stop. Never leave the cab until P.T.O. is disengaged, engine stopped and rotor has stopped spinning.

## Removing From The Tractor

1. Select a level firm site such as a concreted surface
2. Fit parking stands. Place the flail head on the ground approximately 1m out from machine main assembly
3. Disengage P.T.O.
4. Slightly raise lower link arms with great care, enough to carry sufficient weight to remove both stabiliser locking bolts
5. Lower all weight securely onto parking stands.
6. Stop engine; ensure all weight is off the tractor and machine hydraulics by operating the levers in all directions.
7. Remove top link, lower link pins, P.T.O. shaft, and control unit from the cab.
8. Slowly drive tractor away

# Excel 323 Reach Mower

## Layout Of Controls In The Cab

Cable controls



Electric Control

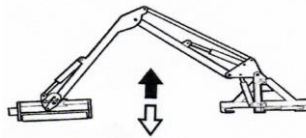
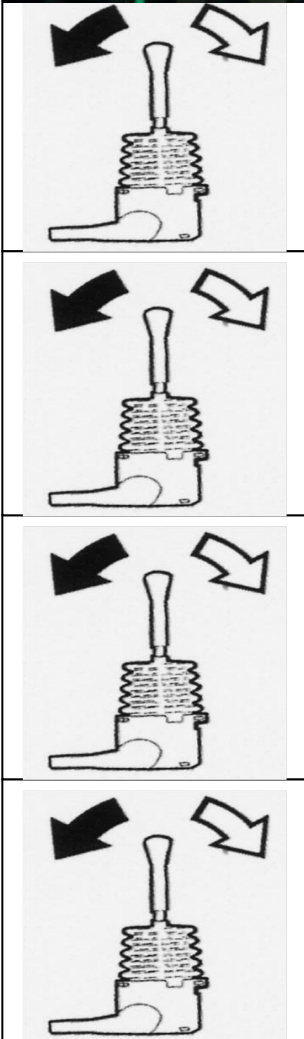

MAIN ARM  
UP AND DOWN

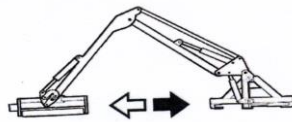

DIPPER ARM  
IN AND OUT

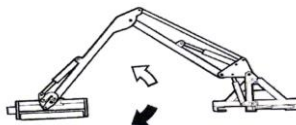

HEAD CONTROL



ROTOR ON/OFF

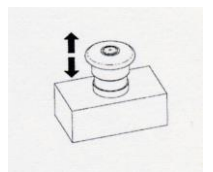

# Excel 323 Reach Mower

## Flail Head

Fitted with a choice of flails,

- Scoop flails for cutting and mulching green vegetation, mowing grass only for a clean finish.
- Back to back flails for cutting and mulching green vegetation, ideal or mowing grass and light scrub.
- Boot flails for trimming annual growth on hedges up-to 20mm diameter.

**NOT** recommended for use on woody material over 25mm.

## Reach Mowing Set-up

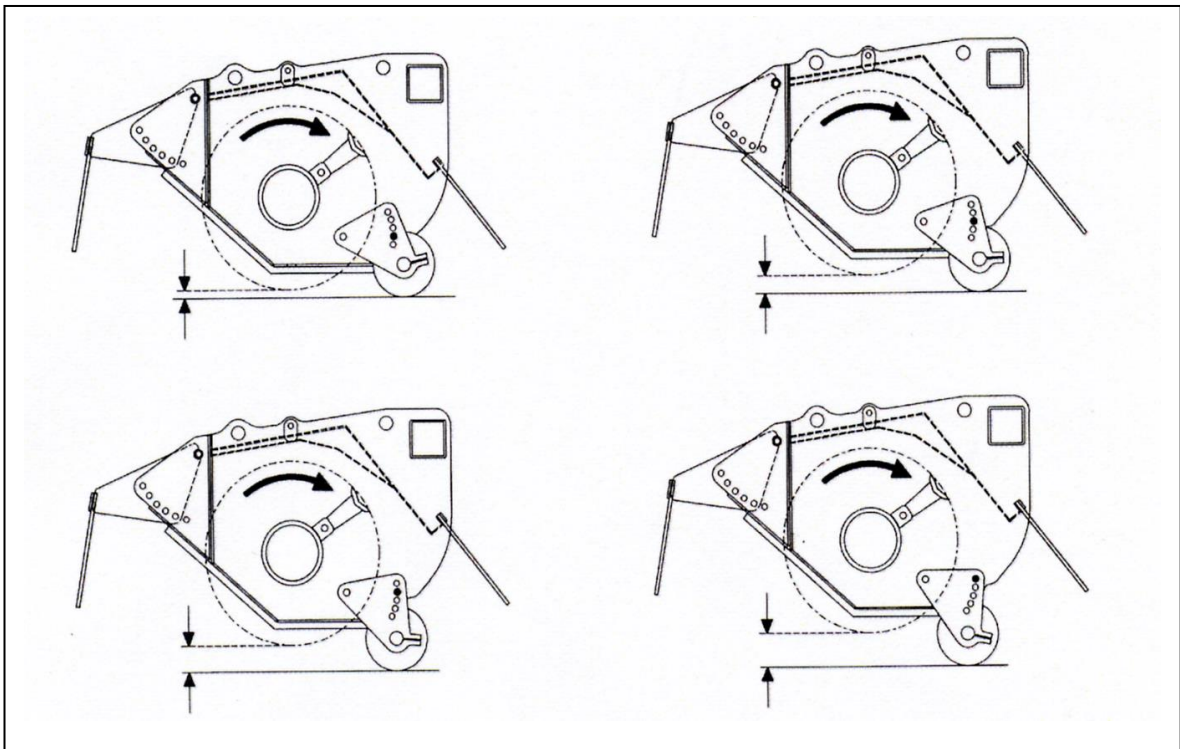

### **Warning**

Never attempt to operate the Machine without the rear roller Correctly fitted. The rear roller is an integral part of the machine giving the necessary support and stability to the head. Failure to adhere to this warning may result in metal fatigue.

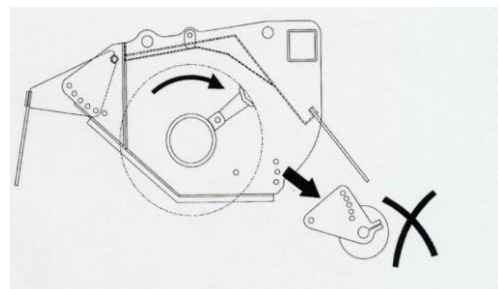

# Excel 323 Reach Mower

## Grass Cutting

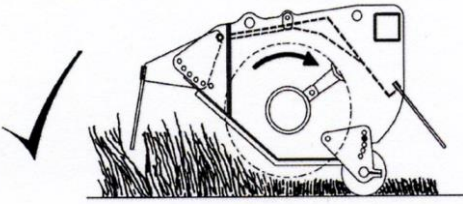

Set rear roller down to control cutting height. Close down the adjustable front hood to reduce flying debris to a minimum.

## Warning

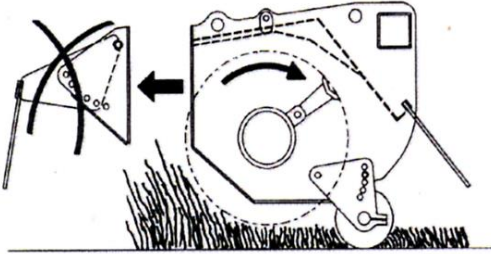

**Never remove  
Front cowl**

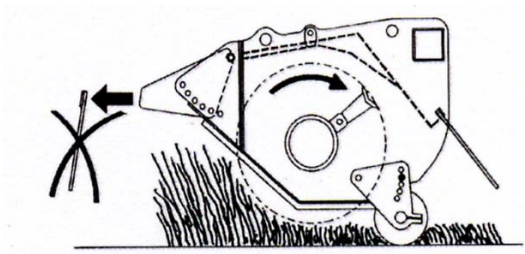

**Do not operate  
Without front flaps**

**Do not verge mow without a rear roller. Do not verge mow with rear roller set too high; remember the rear roller is used to control the cutting height.**

## Tractor Forward Speed

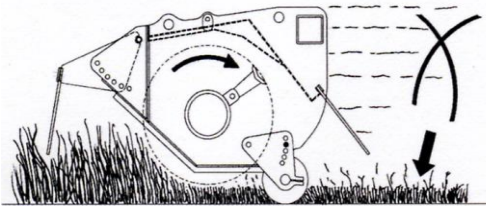

Too high a forward speed will impair the finish, leaving it looking ragged and cause over frequent use of the break back.

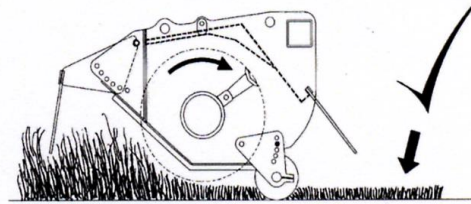

A slower forward speed increases the standard of the finish.

# Excel 323 Reach Mower

## Hedge Trimming

### Recommended Set-Up

- 0.9m rotor
- 4" Rear roller
- "Boot" flails
- Rear flap
- Front flap

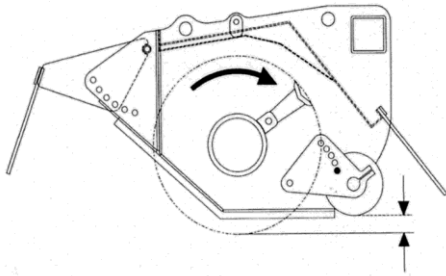

### Roller

should be set to just clear the top of the hedge.

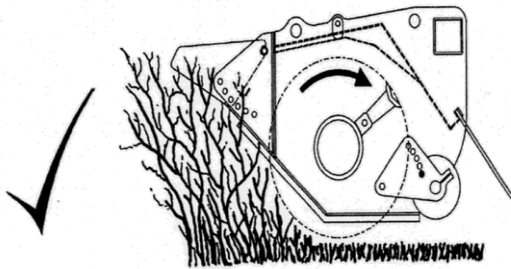

### Hedge Trimming

Flail is cutting upwards reducing flying debris to minimum and leaving a tidy finish. Open adjustable front hood as required.

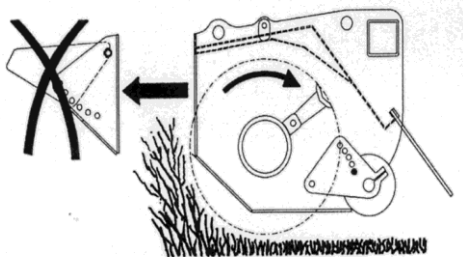

### Warning



Do not remove cowling from the head.

Never attempt to cut thicker material (+20mm) this may cause damage to the rotor not covered under warranty.

# Excel 323 Reach Mower

---



## Warnings

- Never drive the tractor with arm out stretched (except when cutting). When moving at work always first retract arms. Transport with care. Metal fatigue is always caused by careless transportation and misuse. If the ground is uneven or bumpy slow down.
- Read operator's manual and be fully familiar with all operational maintenance and safety procedures.
- Practice in open space without rotor running until familiar with controls. Take care working the head close to the tractor as it may be possible to strike the tractor.
- Remember one of the clever features of the Excel range is its ability to operate within a very narrow space, often within the tractors width. This will mean it is quite possible for the flail head to foul the tractor. Practice all these positions and be very familiar with your machine before ever attempting work.
- Never operate above the recommended P.T.O. speed of 540rpm. Failure to heed this warning will result in severe damage, i.e. greatly increased oil temperature, risk of rotor going out of balance, as well as reduced machine life, and could cause expensive repairs
- Failure to start and stop the rotor at a low P.T.O. speed or to operate at the correct speed will result very quickly in severe motor and/or pump damage
- Be very careful when operating on sloping ground.
- Never attempt to operate the machine while going backwards. It will immediately damage the arms and possibly the flail head. Remember, before selecting reverse gear always lift the flail head out of work and retract the arms towards the tractor.
- If warnings are not followed concerning striking the tractor wheels, particularly when the tractor is moving, the machine may get damaged.



## Engaging Flail Head Drive

1. Select 540rpm P.T.O. and run with **low** engine revs.
2. With flail head in safe position move rotor control lever (5) to 'on'.
3. **Cold start** - it is important not to run at full speed with cold oil. Run at half speed for 5 minutes to allow oil to warm up.
4. After 10 seconds slowly increase engine revs to obtain correct P.T.O. speed, 450 - 540rpm.
5. Never attempt to start rotor while under load.

## Disengaging Flail Head Drive

1. Slowly decrease engine revolutions to a fast idle.
2. Move rotor control lever (5) to 'off'
3. Never increase or decrease P.T.O. speed rapidly, this could seriously damage pumps and motor.

## Cutter Bar

### Description

The optional 1.5m cutter bar is a robust construction of double fingers and reciprocating knife, suitable for cutting shrubs and hedges of a woody material upto 30mm diameter.

### Operation

Run the PTO at low speed 150/200 rpm only; normal 540 rpm will cause unnecessary wear and vibration, which may lead to premature failure. Position the arm and knife into the work and select a suitable forward speed, which allows the blade to cut all material without blocking. When trimming material towards the limit of the cutter bar avoid making arm movements and reduce your forward speed to allow the knife to time to clear.

### Maintenance

- Grease motor body (5 pumps every 50 hours)
- Grease knife drive (1 pump every 50 hours)
- Check tightness and security of all nuts and bolts
- Sharpen or replace worn or damaged blades and fingers

# Excel 323 Reach Mower

## Safety

- When cutting material take care as the branches may fall towards the tractor, always using appropriate guarding on cab glass.
- Never attempt to unblock a jammed knife by hand, always use a suitable tool.
- Always ensure the knife guard is in place before transporting machine.
- Always position the arms and cutter bar on the ground or stands before attempting any maintenance.
- Always disengage the P.T.O. and switch off the engine before attempting and maintenance on the cutter bar.
- Always ensure the engine is switched off, the key removed and the knife has stopped before dismounting the tractor.
- Ensure no person or vehicle is in danger from falling debris in the working area.
- Inspect the work area for hidden obstacles, wire, posts, rocks etc, which may damage the blades or machine.
- Avoid angling the arms or cutter bar into a position, which may contact the tractor, causing damage.

## Transport To Work Position

1. Ensure rotor is off engage P.T.O. low revolutions.
2. Position head vertical 90°.
3. Lower main lift ram only until main arm is vertical.
4. Extend dipper arm outward.
5. Position head till horizontal, just above ground.

## Moving Into Transport Position



1

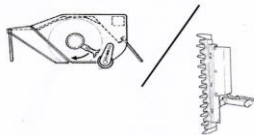

Disengage head motor drive.



2

Set main arm at 45 degrees.

# Excel 323 Reach Mower



3

Slowly operate dipper arm towards stop on main arm until fully closed.



4

Fully raise main arm, and slowly close head ram. Finally disengage P.T.O. drive.



## **Warning**

Avoid high transport speeds, which will cause unnecessary strain on Machine and tractor.  
Never travel with the reach ram away from bump stop on the main Arm. Failure to heed this warning will cause damage to the ram Seals.

## **Transport Position**

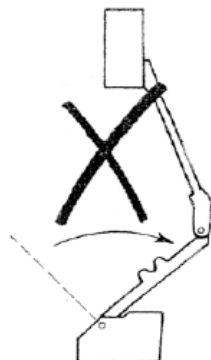

## **Warning**

To avoid severely damaging the dipper arm, never fully close main arm and drop dipper arm quickly.

## Cutting Sequence For Cutter Bar

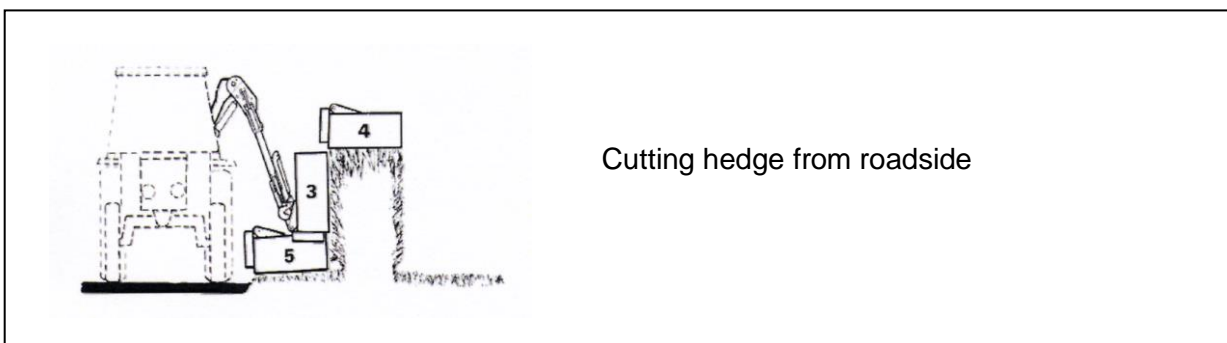
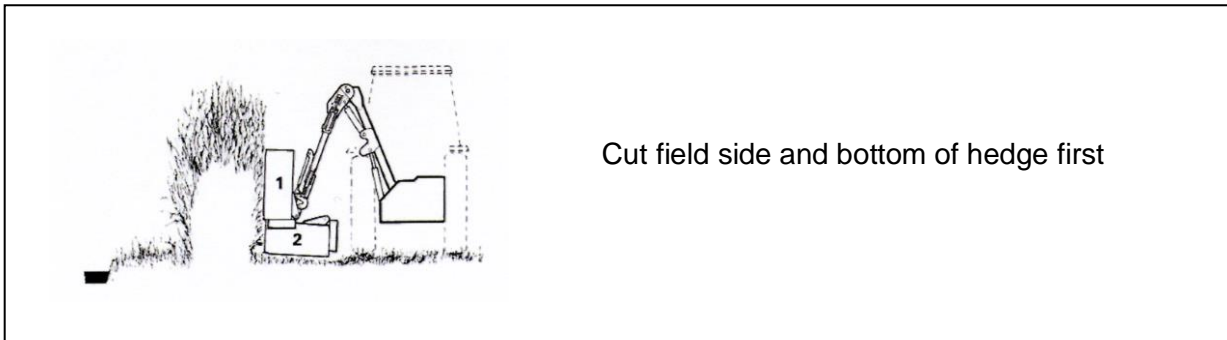

## Break Back

The Excel 323 range of reach mowers have, as standard, a breakaway link for machine protection, should an obstacle be encountered while travelling forward

The break back link will operate if the machine is overloaded i.e. a dense patch of vegetation, too high a forward speed, and when working uphill. The tractor must be halted and flail head manoeuvred around the obstacle, the machine then reset before continuing.

# Excel 323 Reach Mower

## Wire Trap

- This is located under the front hood. It must not be interfered with in any way.
- Any wire must be removed immediately
- Select Rotor control lever to 'off' and wait until rotor stops spinning. Lower rotor to ground, disengage P.T.O. and stop engine before leaving cab.



### **Warning**

Wire is extremely dangerous and must be avoided at all times. Inspect work area before commencing; removing all loose wire and clearly marking fixed wire

## High Voltage Cables



### **Warning**

Always be very aware of overhead cables. Between poles wires can be well within reach of the machine. If in any doubt of the danger, consult your local electricity company regarding a safe procedure for work.

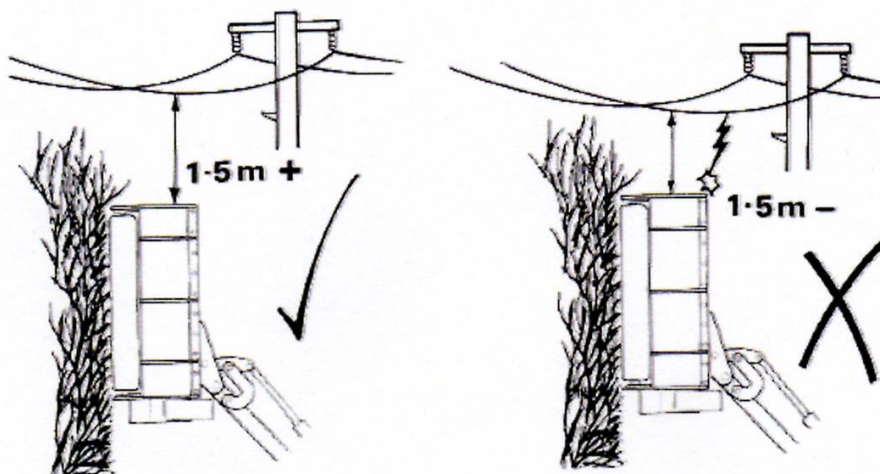

# Excel 323 Reach Mower

---

## Debris Blower

Hydraulically driven fan from tractor external services please quote tractor oil flow when ordering maximum 40lt per min.

The return oil must go to a free flow connection i.e. filler plug.

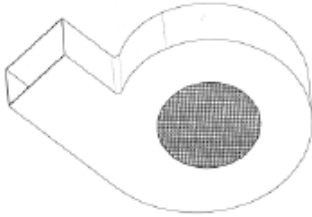

### Operating the Debris blower

The fan is suitable for clearing cuttings off the highway; we recommend the blower is used on final cut only and not continually on.

Excessive use may cause overheating. The unit can be angled for the best effect.

### Transport

The blower housing protrudes and care should be taken not to damage unit.

## Oil Cooler

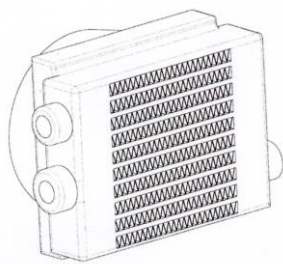

Prolongs the life of the oil and hydraulic components in hot and arduous conditions.

# Excel 323 Reach Mower

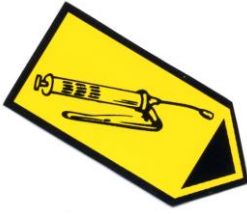

All the following grease points  
Need to be greased daily.

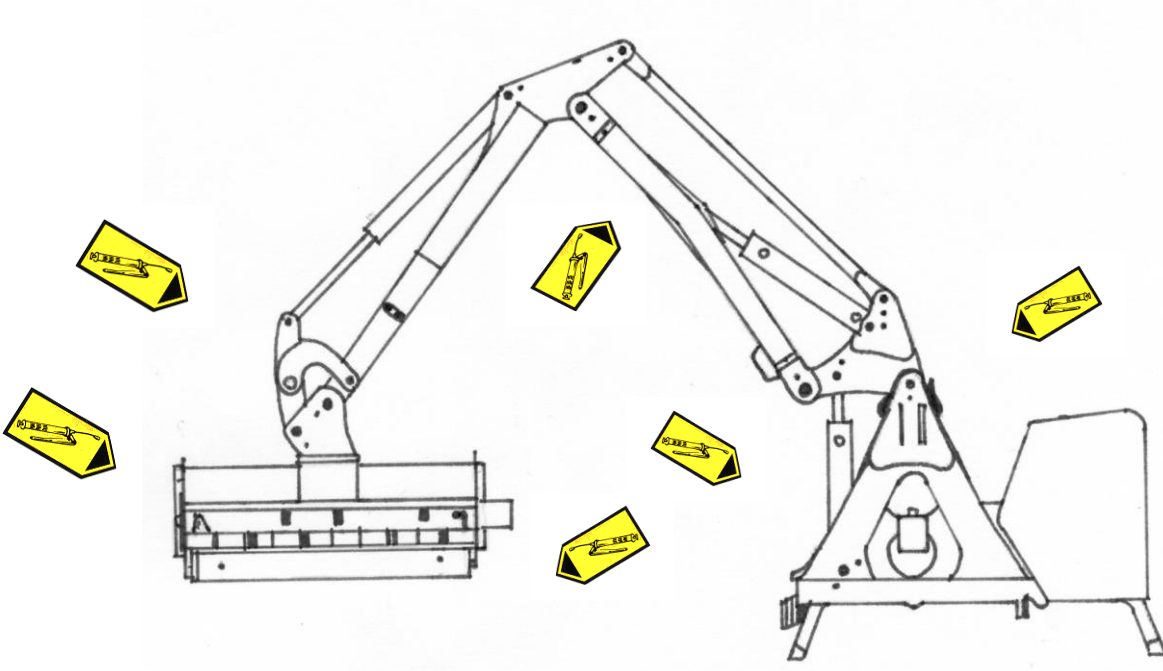

## Lubrication Chart

	Daily	Weekly	Monthly
Rotor shaft bearings			
P.t.o. shaft bearings			
P.t.o. shaft tubes			
Pivot pins			
Roller bearings			
Oil tank			
Gearbox			
Motor drive			
Flail head			

Key:

Grease =

Oil =

Check =



# Excel 323 Reach Mower

---

## Greasing/Lubrication

### Washing your machine

Grease all your machine and optional parts after each time you wash your machine.

### Gearbox

Before first use check gearbox oil level, thereafter check every 8 hours. After the first 50 hours drain and replace the gearbox oil, thereafter annually. Replace with EP90. Do not over tighten oil plugs, as this will damage the housing.

### P.T.O.

Dismantle; clean the input drive shaft sliding surfaces and re-grease, failure to do this will result in serious damage to the gearbox. Grease both U.J. joints every 8 hours.

## Torque Settings

The Torque figures given below are recommended maximum settings only.

Size:	Tensile strength:	Description:	Torque setting: Nm.
M10	8.8	General fasteners	65
M12	8.8	General fasteners	114
M12	12.9	Head bolts	170
M12	10.9	Flail bolts	100
M16	8.8	Head bracket bolts	280

# Excel 323 Reach Mower

## Hydraulic Hoses

- Carefully check condition of all hoses during routine service paying particular attention to chafed outer casing. Secure wrap with waterproof adhesive tape to stop the metal braid from rusting.
- Daily inspect all hydraulic hoses and fittings to be in good order. Any damages or leaks must be rectified immediately; this is part of the daily maintenance and is your responsibility, to ensure a long reliable working life.
- Hoses with damaged metal braid should be replaced.
- When replacing hoses quote number stamped on fitting at one end. The Spearhead hydraulic system works at very high pressure, when replacing hoses use only genuine hoses, a burst hose could be very dangerous.
- When replacing hoses to avoid twisting fitting, use two spanners to slacken and tighten

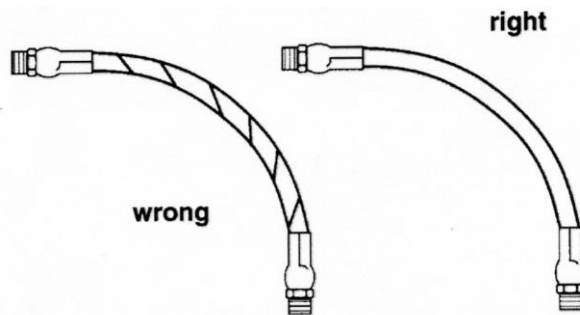

### **Warning**

Hose is weakened when installed in twisted position. Also, pressure pulses in twisted hose tend to fatigue wire and loosen fitting connections. Design so that machine motion produces bending rather than torsion.

- Always check the yellow protective sleeve is in good order, to replace sleeve is far cheaper than replacing expensive hoses.
- Hose warranty is limited to replacement of hoses due to faulty materials or manufacture Warranty will not be considered on hoses damaged by chafing, abrasion, cuts or pinching while in work, or to damaged threads due to over tightening.
- All hose connections are of a "Parker" soft seal type and only need 1/2 a turn more than finger tight to become leak-proof (see table below).

<b>BSP (Size)</b>	<b>Tightening (Nm)</b>	<b>Torque (lbsf/ft)</b>
1/4"	24	18
3/8"	33	24
1"	115	85

# Excel 323 Reach Mower

---

## Oil Supply

- Daily before starting up check oil level in tank reservoir.
- It is a good practice to constantly keep an eye on the tank level gauge, (this can be seen from the tractor seat) as a pipe burst could empty the tank within minutes.
- A pump or motor starved of oil will be damaged beyond repair.
- Replace oil if signs of contamination occur (discoloured)
- Contamination can be reduced by:
  - Thoroughly cleaning around reservoir cap before removing.*
  - Using a clean container when replenishing the system.*
  - Regularly servicing the filtration system.*
  - Never allowing oil level to fall below the sight gauge.*
- Daily inspect all hydraulic connections and fittings to be in good order. Any damage or leaks must be rectified immediately, this is part of the daily maintenance and is your responsibility, to maintain a long reliable working life.
- When tightening fittings always use two spanners when necessary and do not over tighten. If a fitting leaks it will need to be replaced.

## Filtration Maintenance

The machine is protected by a suction strainer and a low pressure full flow return line filter.

1. The suction filter is permanently fixed in the reservoir tank. Should symptoms of pump cavitations or spongy operation occurs, the tank must be drained, the tank and suction filter thoroughly cleaned and dried before refilling with clean oil.
2. The return line filter element should be replaced after the first 50 hours and thereafter at 300-hour intervals. It is most important to replace the filter within these intervals because once blocked, oil will bypass the filter element infiltrated.
3. When tightening fittings always use two spanners when necessary and do not over tighten. If a fitting leaks it will need to be replaced.

# Excel 323 Reach Mower

---

## Flail Head

- Grease all bearings daily.
- Check there is no wrapping of string, plastic, grass or other debris on rotor shaft and rear roller bearings
- Check the condition of flails and ensure all retaining bolts are tight. When flails are replaced care must be taken to maintain balance of rotor shaft, do not change to a different type.
- Flail retaining bolt and nut - keep tight
- Flail head is supplied centre mounted to get best travel on crowd ram.
- Never operate with any flails missing. This will cause severe vibration and lead to rapid bearing wear and quickly cause the head to crack.
- Blunt flails leave an untidy finish and absorb excessive power, when re-sharpening always wear protective clothing and goggles.
- When flails are showing severe wear, damage or cracking, they must be replaced immediately. Never attempt to weld the flails, this will make them very brittle and is extremely dangerous. Do not take risks with the cutting flails - if in doubt replace.
- When replacing flails always replace bolts and nuts for new.
- Regularly check that all rotor bearing bolts and hydraulic motor retaining bolts are tight.
- With a new machine or if new bolts have been fitted, particular attention needs to be applied to regular tightening of the new bolts (1hr - 4hrs then daily).



### **Warning**

Mounted head may foul on machine or tractor cab.

# Excel 323 Reach Mower

## Pins & Bushes

All main pivot points are furnished with replaceable bushes. If there are any signs of wear, these must be replaced. All bushes are available from Spearhead Parts Department.



### **Warning**

Do not use grease containing Molybdenum disulphide on nylon bushes and wear pads.

## Storage

Remember regular maintenance will greatly increase the life of the machine.

Before storing away, thoroughly wash the machine removing all traces of grass and dirt. Care must be taken when washing with high-pressure hoses, do not hold the water jet close to the paintwork. Use steam cleaners with caution, be sure to remove all detergents to avoid any discolouring or damage to paint. Grease all grease points until fresh grease shows. It is important where possible to store undercover to protect against rain and sunlight. Always ensure a firm level surface. Control levers must be wrapped in plastic sheeting and taped over to keep dry.

Smear greaser on all areas vulnerable to corrosion, in particular the chrome on the ramrods.

Before you attempt to do any repairs, service, maintenance or adjustment on your machine, ensure the engine has stopped and the key removed. P.T.O. is disengaged, handbrake secure, and the head is firmly on the ground.

## Regular Services Chart

Service Hours	Service points	Page	Grease	Drain	Check	Clean	Change
1 - 4 hrs	Bolts are fully tightened				X		
	Condition of flails				X		
	Condition of hoses especially for chafing				X		
	Flail head bolts are fully tightened	31			X		
	Flail head retaining bolts are fully tightened				X		
	Gearbox seals (If oil is leaking replace immediately)				X		(X)
	Inspect leaks from fittings and pipes				X		
	Pins and bushes	32			X		
	Rotor bearing bolts are fully tightened	31			X		
8 hrs	Bearings	27	X				
	Gearbox & pump bolts are fully tightened				X		
	Gearbox oil level	28			X		
	Grease points & P.T.O shaft	28	X				
	Oil level in reservoir	30			X		
	U.J. joints	28	X				
50 hrs	Gearbox oil (use EP 90 oil)	28		X			X
	Return line filter element	30					X
250-300 hrs	Return line filter element	30					X
	Hydraulic oil if any signs of contamination appears	29		X	X		

## Pump & Motor Failure

### Care & Attention

#### Adhere to the following points:

- Never run out of oil.
- Never run a cold machine straight up to speed, first ensure engine revolutions are low then engage/disengage the head motor.
- Never increase or decrease engine speed quickly.
- Never stop or start rotor at high engine speed.
- Never transport with P.T.O. in gear.
- Never operate in 1000 rpm. P.T.O. speed (economy gear).
- Regularly check condition of suction line hose.
- Never operate above recommended P.T.O. speed, 540 R.P.M.
- Check that pump fittings are tight.
- If any strange noise occurs from the hydraulics, stop immediately and investigate.
- Remember, pump and motor warranty is limited to replacement due to faulty materials or manufacturer. Cavitations and peak pressures are very easily detected on pump inspection.
- Warranty will not be considered if fault is due to misuse.
- Never cause severe sudden movements to arms. Pressure will peak and will transmit back to pump, resulting in failure.

## The Spearhead Warranty

Spearhead warrants that the Spearhead machine referred to in the Warranty Registration Form will be free from defects in materials and workmanship for a period of 12 months from the date of sale. This warranty does not affect your statutory rights, but merely adds to them. Should you have a problem within 12 months from the date of sale please contact your original Spearhead dealer, or Spearhead's Service Department. Any part found to be defective during this period would be replaced or repaired, at Spearhead's discretion, by the dealer or a Spearhead Service Engineer.

### Spearhead Warranty Conditions

1. The Warranty Registration Form must be completed and returned to Spearhead within 30 days of the date of sale.
2. This warranty does not cover defects arising from fair wear and tear, willful damage, negligence, misuse, abnormal working conditions, use in competition, failure to follow Spearhead's instructions (oral or written, including all instructions and recommendation made in the Operator's Manual) or alteration or repair of the machinery without Spearhead's approval.
3. The machinery must have been serviced in accordance with the Operator's Manual and the Service Log must have been kept up to date and made available to the dealer should service, repair or warranty work be undertaken.
4. This warranty does not cover claims in respect of wearing parts such as blades, flails, paintwork, tyres, belts, hydraulic hoses, bearings, bushes, linkage pins, top links, ball ends unless there is a manufacturing or material defect or the cost of normal servicing items such as oils and lubricants.
5. This warranty does not cover any expenses or losses incurred whilst the machinery is out of use for warranty repairs or parts replacement.
6. This warranty does not extend to parts, materials or equipment not manufactured by Spearhead, for which the Buyer shall only be entitled to the benefit of any such warranty or guarantee given by the manufacturer to Spearhead. Only genuine Spearhead replacement parts will be allowable for warranty claims.
7. All parts replaced by Spearhead under warranty become the property of Spearhead and must be returned to Spearhead if Spearhead so request. Such parts may only be disposed of after a warranty claim has been accepted and processed by Spearhead.
8. Spearhead is not liable under this warranty for any repairs carried out without Spearhead's written consent or without Spearhead being afforded a reasonable opportunity to inspect the machinery the subject of the warranty claim. Spearhead's written consent must, therefore, be obtained before any repairs are carried out or parts replaced. Use of non-Spearhead parts automatically invalidates the Spearhead Warranty. Failed components must not be dismantled except as specifically authorized by Spearhead and dismantling of any components without authorization from Spearhead will invalidate this warranty.
9. All warranty claims must be submitted to Spearhead on Spearhead Warranty Claim Forms within 30 days of completion of warranty work.



# Excel 323 Reach Mower

---

**Using the machine implies the knowledge and acceptance of these instructions and the limitations contained in this Manual**

## **Extended Warranty**

As an extension to the 12-month warranty set out above, Spearhead will provide an additional 12 month warranty cover subject to the Spearhead Warranty Conditions above and the Extended Warranty Conditions below.

### **Extended Warranty Conditions**

1. The extended warranty applies to hydraulic pumps, motors, valves and gearboxes only. It does not apply to other parts, to consumables such as lubricants, seals or filters or to labor charges
2. The machinery must have had an annual service carried out by an Authorized Spearhead Dealer or a Spearhead Service Engineer within 1 month of the first anniversary of the date of sale and the Service Report form must have been completed and stamped by the servicing dealer or Spearhead Service Engineer and sent to Spearhead within 14 days after the first annual service.
3. The extended warranty does not cover costs of transportation of the machinery to or from the dealer or Spearhead or the call out costs or traveling expenses of on-site visits.

### **Transfer of Warranty**

The Spearhead warranty may be transferred to a subsequent owner of the machinery (for use within the UK) for the balance of the warranty period subject to all of the warranty conditions and provided that the Change of Owner form is completed and sent to Spearhead within 14 days of change of ownership.

**Spearhead reserves the right to make alterations and improvements to any machinery without notification and without obligation to do so.**

# Excel 323 Reach Mower

---