

**Spearhead Machinery  
Operator Instruction Manual For**

**MULTICUT 160/200**

**1.6-2.0m cut width, 540 PTO input**

**Vegetation control mounted rotary mower**

**8999176EN v1**

# IMPORTANT

## Verification Of Warranty Registration

### Dealer Warranty Information & Registration Verification

It is imperative that the selling dealer registers this machine with Spearhead before delivery to the end user.

**Failure to do so may affect the validity of the machine warranty.**

To register machines go to the Spearhead Machinery Limited web site at:

<https://my.spearheadmachinery.com/warranty/machine-registration/>

Should you experience any problems registering a machine in this manner please contact the Spearhead Service Department on 01789 491860.

Confirm to the customer that the machine has been registered in the section below.

### Registration Verification

<b>Model Type:</b>		<b>Multicut</b>
<b>Model Number:</b>		<b>99</b> _____
<b>Serial Numbers:</b>	<b>Machine:</b>	<b>S</b> _____
	<b>Cutting Implement:</b>	<b>S</b> _____
	<b>Other:</b>	
<b>Name Of Owner:</b>		
<b>Name Of Installing Dealer:</b>		
<b>Dealer Address:</b>		
<b>Dealer Signature:</b>		
<b>Date Of Delivery / Installation:</b>		
<b>Date Of Warranty Registration:</b>		

#### IMPORTANT

At the point of transfer of ownership record the above information. Note the serial number of your machine and always quote it in any communication with us or your dealer. (The serial number plate is located on the machine mainframe.) This is particularly important when ordering spares. Remember to include all numbers and letters.

The information given throughout this manual is correct at the time of publication. However, in the course of constant development of Spearhead machines, changes in specification are inevitable. Should you find the information given in this book to be at variance with the machine in your possession, you are advised to contact the Spearhead Service department where up-to-date information will be provided.

The manual can contain standard and optional features and is not to be used as a machine specification. The machine has been tested and is considered safe if carefully used. Ensure your operator is properly trained in its use and maintenance.

(This page is left blank intentionally)

## Multicut Mounted Rotary Mowers

This manual covers the Multicut series of mounted single rotor rotary mowers which are available in either a 1.6m or 2.0m cut widths.

These mounted machines can be specified with various specifications of blade/chain carriers to suit the end users specific requirements.

These machines are fitted with 540 rpm as standard and are available with various input shaft options.

It is essential that the safety guards and chains are always fitted during operation and that the machine is operated in line with the procedures and practices detailed in this manual.

### IMPORTANT

This operator's manual should be regarded as part of the machine. Suppliers of both new and second-hand machines are advised to retain documentary evidence that this manual was provided with the machine.

This machine is designed solely for ground vegetation control and must not be used for any other purpose. Use in any other way is considered as contrary to the intended use. Compliance with, and strict adherence to, the conditions of operation, service, and repair, as specified by the manufacturer, also constitute essential elements of the intended use.

This machine should be operated, serviced, and repaired only by persons who are familiar with its characteristics and who are acquainted with the relevant safety procedures.

Accident prevention regulations, all other generally recognised regulations on safety and occupational medicine, and all road traffic regulations must always be observed.

Any arbitrary modifications carried out to this machine may relieve the manufacturer of liability for any resulting damage or injury.

It is potentially hazardous to fit or use any parts other than genuine **Spearhead** parts.

The company disclaims all liability for the consequences of such use which, in addition, voids the machine warranty.

(This page is left blank intentionally)

## Contents List

1	Machine Description .....	8
	1.1 Intended Usage .....	8
	1.1.1 Allowed Uses .....	8
	1.1.2 Improper Uses .....	8
	1.2 General Arrangement .....	9
	1.2.1 Diagram .....	10
	1.3 Machine Identification .....	11
	1.4 Rotation Definitions & Conventions .....	12
	1.5 Machine Specification .....	13
	1.5.1 Standard Specification .....	13
	1.5.2 Machine Options .....	14
2	Safety .....	16
	2.1 Level Of Danger .....	16
	2.2 Terminology .....	16
	2.3 Safe Use .....	17
	2.3.1 Health and Safety Executive (HSE) Guide Sheets .....	17
	2.3.2 Health and Safety Executive (HSE) Safe Stop Campaign .....	17
	2.3.3 Operators Manual .....	18
	2.3.4 Personnel Preparation .....	18
	2.3.5 Tractor And Machine Preparation For Work .....	19
	2.3.6 Work Site Preparation .....	23
	2.3.7 Machine At Work & Observation .....	25
	2.3.8 Transporting The Machine .....	27
	2.3.9 Machine Storage .....	28
	2.4 Safe Maintenance .....	28
	2.5 Safety & Operational Decals .....	31
	2.5.1 Definitions .....	31
	2.5.2 Placement .....	33
	2.5.3 Replacement .....	33
	2.6 Guards .....	33
	2.6.1 Mandatory Guards .....	34
	2.7 Sound .....	34
	2.8 Personal Protective Equipment .....	34
	2.9 The Machine & The Environment .....	35
	2.9.1 Disposal .....	35
	2.10 Proposition 65 .....	36
3	Machine Preparation .....	38
	3.1 Lifting The Machine .....	38
	3.2 Post-delivery/First Use Inspection .....	38
	3.2.1 Tractor Inspection .....	38
	3.2.2 Machine Adjustment .....	38
	3.3 PTO Shaft .....	39
	3.3.1 PTO Setup & Adjustment (first use) .....	39
	3.3.2 Bottoming Out Test .....	40
	3.3.3 Modifying & Shortening The Input PTO Shaft .....	40
	3.3.4 Fitting The PTO Shaft .....	42
4	Usage Instruction .....	44
	4.1 Operator Requirements .....	44
	4.2 Tractor Requirements .....	45
	4.3 Hitching & Unhitching The Machine .....	46
	4.4 PTO Shaft .....	48
	4.4.1 Fitting & Removal Of The Input PTO Shaft .....	48
	4.4.2 PTO Shaft Specifications .....	51
	4.5 Setting Up The Machine .....	51
	4.5.1 Front To Rear .....	51
	4.6 Setting Cutting Height .....	53
	4.6.1 Multicut 160/200 .....	53
	4.7 Work Site Assessment .....	56
	4.7.1 Foreign Debris Hazards .....	56
	4.7.2 Stopping The Machine In An Emergency .....	57

4.7.3	Bystanders.....	57
4.7.4	Weather .....	57
4.7.5	Fire.....	58
4.8	Safe Driving Practices.....	58
4.9	Using The Machine .....	60
4.9.1	Engaging The Power Take-off (PTO) .....	60
4.9.2	Disengaging the Power Take-off (PTO).....	60
4.9.3	Forward & Power Take-off Speed.....	61
4.9.4	Cornering.....	62
4.9.5	Crossing Ditches & Steep Inclines .....	62
4.9.6	Un-level Ground .....	63
4.10	Road Transporting The Machine .....	63
4.11	Transporting The Machine On A Trailer .....	64
5	Maintenance .....	66
5.1	Periodic Maintenance.....	66
5.2	Lubrication & Greasing.....	66
5.2.1	Gearboxes .....	66
5.2.2	PTO Shaft.....	69
5.2.3	General Machine Greasing Point Locations .....	70
5.2.4	Greasing Schedule.....	71
5.3	PTO Shaft.....	71
5.3.1	Size Adjustment & Fitting To The Tractor .....	71
5.3.2	Greasing .....	71
5.3.3	Input PTO shaft - Bearing Ring Replacement .....	72
5.4	Slip Clutch .....	74
5.4.1	Slip Clutch Disassembly & Servicing .....	74
5.4.2	Freeing Seized Clutch Plates.....	77
5.4.3	Clutch Settings.....	78
5.5	Blade/Chain Carriers, Blades, Chains & Anti-Scalp Dishes.....	78
5.5.1	Blade/Chain Carrier Options .....	78
5.5.2	Blade Inspection .....	79
5.5.3	Chain Inspection.....	80
5.5.4	Blade Sharpening & Straightening.....	82
5.5.5	Blade/Chain Removal & Replacement .....	82
5.5.6	Blade/Chain Bolt Inspection .....	84
5.5.7	Anti-scalp Dish Inspection .....	85
5.5.8	Anti-scalp Dish, Blade/Chain & Blade/Chain Carrier Removal & Replacement .....	87
5.6	Wheel, Hub & Tyre.....	90
5.6.1	Tyre Pressures .....	90
5.6.2	Hub Greasing .....	91
5.7	Other Key Components .....	92
5.7.1	Pins & Bushes .....	92
5.7.2	Skids .....	92
5.8	Torque Settings.....	93
5.8.1	Nuts & Bolts .....	93
5.8.2	Other Items .....	93
5.9	Machine Inspection Record .....	94
5.10	Machine Storage .....	96
5.10.1	Preparing The Machine For Storage.....	96
5.10.2	Returning The Machine Back To Work.....	97
6	Troubleshooting .....	98
7	Spare Parts .....	100
7.1	How To Obtain The Correct Spare Part Numbers .....	100
7.2	Spare Parts Ordering .....	101
7.3	Dealer Network .....	101

# 1 Machine Description

## 1.1 Intended Usage

### 1.1.1 Allowed Uses

The Multicut series of mounted single rotor rotary mowers are developed for farmers or small-scale contractors and are popular with aviation authorities. These versatile machines can be used for cutting set-aside, stubble and pasture.

The Multicut series of mounted single rotor rotary mowers are designed for use on level, undulating or inclined ground and for a duty cycle of 1000 hours per annum. They will cut vegetation up to 100mm/4" thickness.

They can be mounted to agricultural tractors with a minimum of 40hp (Multicut 160) and 50hp (Multicut 200).

### 1.1.2 Improper Uses



**DANGER!** Spearhead declines any and all liability for damages caused by the machine to persons, animals or property, resulting from use in any other way than described in this manual, or due to damage caused by negligence or by not observing the instructions contained in this manual.

The machine, due to its typical construction, may also be suitable for uses other than from those foreseen by the manufacturer. For this reason Spearhead has selected, as non-exhaustive examples, a series of improper uses that can be reasonably foreseen, which are:

- Using the machine for amenity mowing purposes.

The uses listed above and those not specifically indicated in this manual, including reasonably foreseeable improper uses, are definitively prohibited.



**Figure 1.1 Spearhead Mounted Single Rotor Multicut**  
(200 model illustrated)



## 1.2 General Arrangement

The layout and naming convention used throughout this manual for each of the machines are shown in the table below. The numbering and positioning of the relevant item can be found for the machines in Section 1.2.1.

Item No.	Description
1	Deck
2	Wheel Arm & Yoke Assembly
3	Gearbox
4	PTO (Power Take-off) With Two-plate Slip Clutch
5	Height Adjuster Pin
6	Headstock
7	Wire Rope
8	Blade*
9	Anti-scalp Dish*
10	Skid
11	Chain Guard
12	Guide Wheel

**Table 1.1 – Multicut 160/200 Machine Components**

\* Multicut 160/200 machines can be specified in a variety of specifications when purchased brand new. Figure 1.2 shows an example Multicut 160/200 specification. It is important to state the actual supplied machine may vary to the layout and specification as shown in Figure 1.2.

A full list of Multicut 160/200 specification options can be found in Section 1.5.2.

1.2.1 Diagram

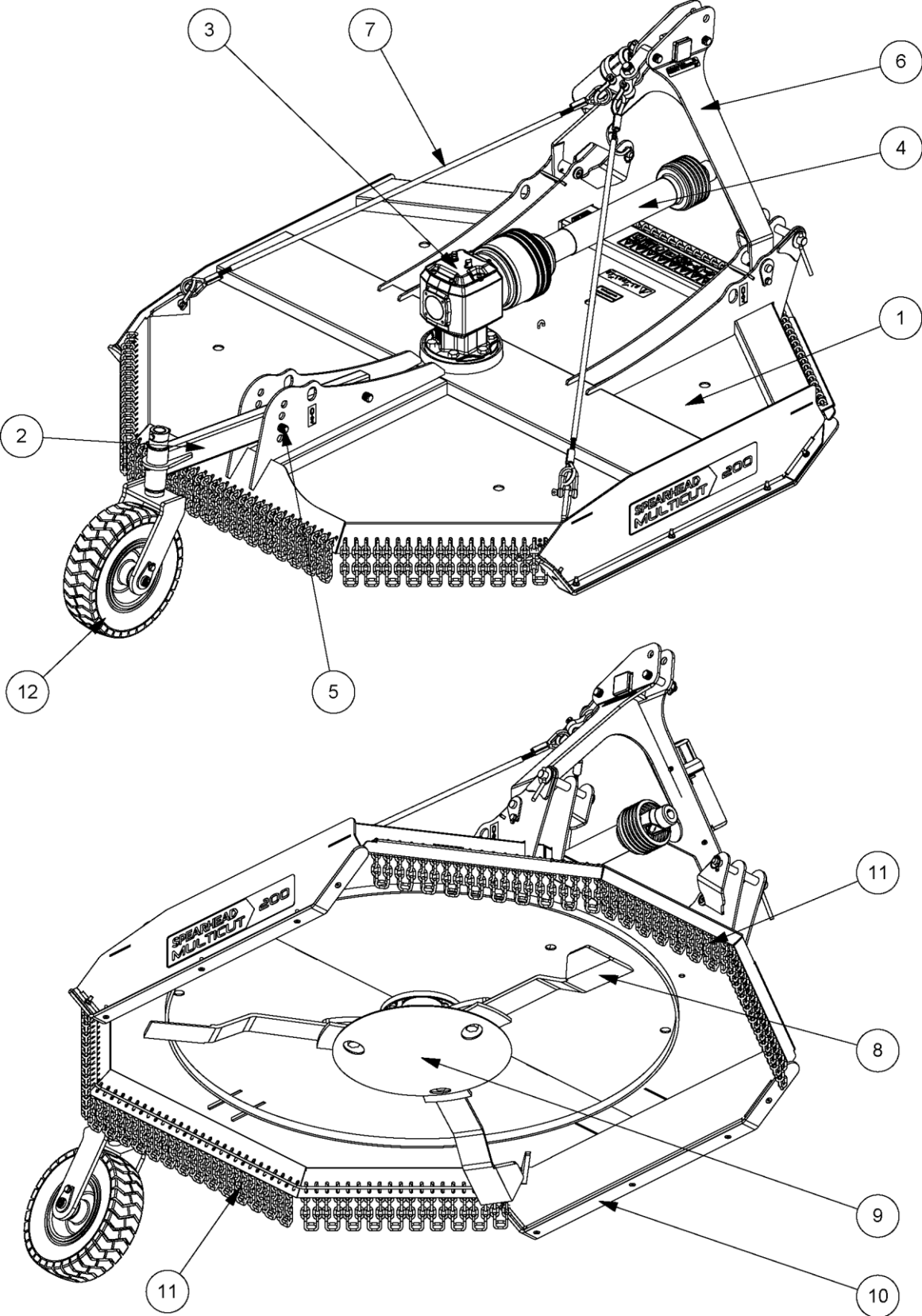

OPMAN01445

Figure 1.2 – Multicut 160/200 General Arrangement  
(200 model illustrated)

## 1.3 Machine Identification

Each machine is equipped with a serial plate; see Figure 1.3 that includes the following data in this order:

1. UKCA Conformity Marking.
2. Machine Whole Goods Code (WGC).
3. Serial number of the machine.
4. Mass in kg.
5. Production Year (year of construction).
6. Design conformity standard.
7. Machine Product Group Code.
8. EU Authorised Representative QR scan code.
9. Manufacturer marking with name and address.
10. EAC Eurasian/Russian Conformity Marking.
11. EC European Conformity Marking.
12. Product Group Code.

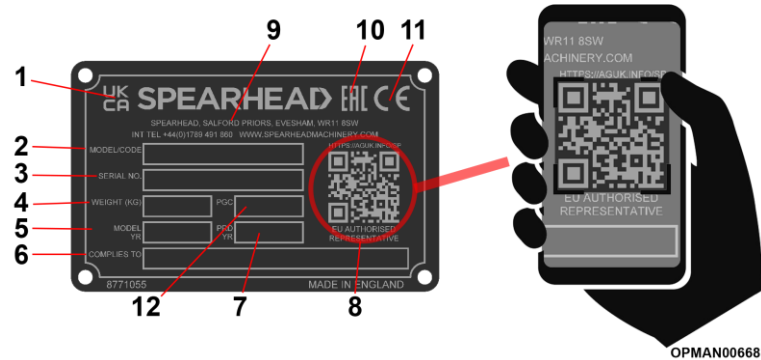

**Figure 1.3 – Serial Plate**

Data on the Spearhead manufacturer's plate should always be referred to when requesting assistance and/or requiring replacement spare parts.

This data can identify the machine and its characteristics and specification for its particular time of manufacture, certifying that it responds to current regulations. For this reason the plate should never therefore be removed nor be used for other purposes; if the machine is dismantled, it should be destroyed to prevent any form of abuse.

By utilising a smart phone and scanning the Authorised Representative QR scan code found on the right-hand side of the serial plate (ref 8, Figure 1.3) using a suitable QR scanning App, you can find details for Spearhead Machinery authorised representatives for its various territories.

The serial plate is located on the front channel of the machine, underneath the headstock; see Figure 1.4.

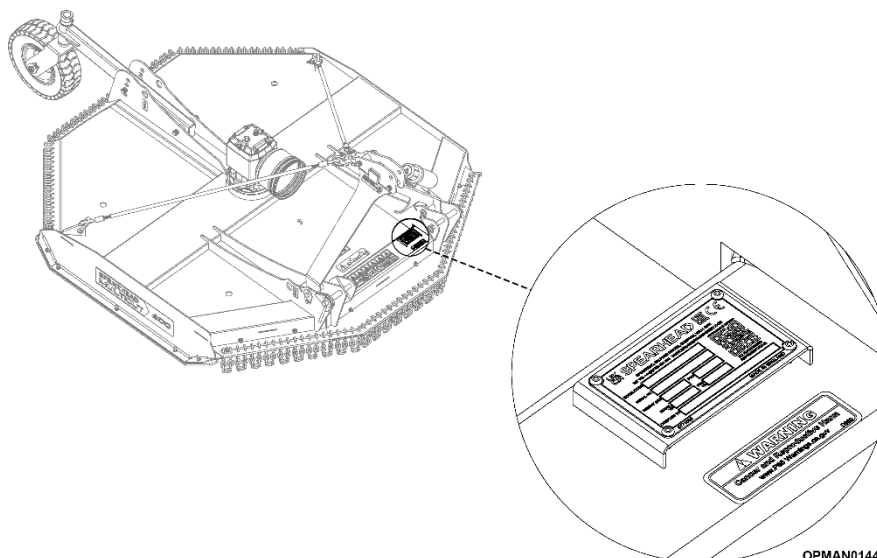
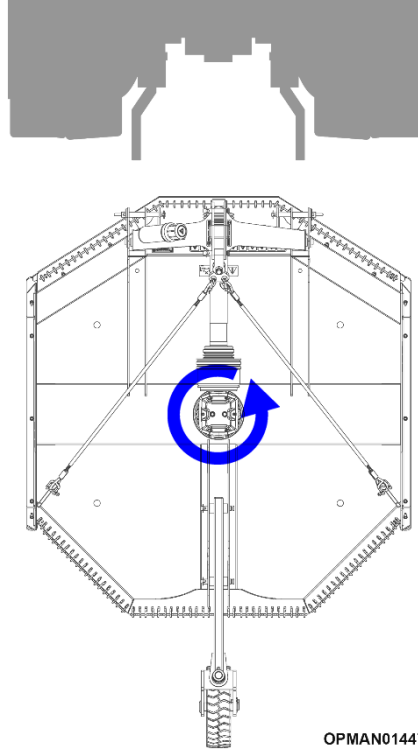

**Figure 1.4 – Serial Plate Location**  
(200 model illustrated)

## 1.4 Rotation Definitions & Conventions

This instruction manual refers to relative rotational directions. The terms clockwise and anti-clockwise are defined by looking down at the machine from above, with the tractor being at the front; see Figure 1.5. To eliminate confusion the following definitions will be used throughout this operator's manual.

The rotation direction of the rotor is stated in Figure 1.5.



OPMAN01447  
**Figure 1.5 – Blade Rotation**  
 (200 model illustrated)

Additionally, other references to 'clockwise' and 'anti-clockwise' actions by the operator conform to international right-hand thread conventions for 'screw down' and 'un-screw' respectively.

This convention also extends to the definition of PTO drive rotation from the prime mover, see Figure 1.6.

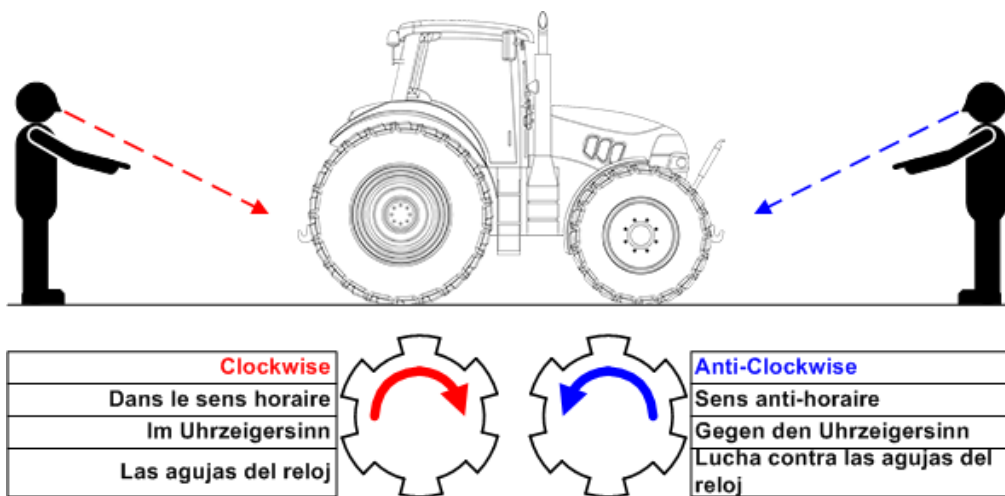

OPMAN00009  
**Figure 1.6 – Tractor PTO Shaft Rotation Definitions**

## 1.5 Machine Specification

### 1.5.1 Standard Specification

Multicut		160	200
Tractor	Recommended Minimum Tractor HP	40hp/30kW	50hp/37kW
	PTO	540 RPM	
PTO	Speed	540 RPM	
	Size	35mm (1 3/8 inch), 6 spline (standard) or 21 spline (optional)	
	Protection	2 plate slip clutch	
Machine (1) (2)	Mass	TBC	TBC
	Hitch	Category 1/2 mounted with floating clevis top link	
	Cutting Width (A)(1)(2)	1.60m (5' 3")	1.90m (6' 3")
	Machine Width (B)(1)(2)	1.80m (5' 11")	2.09m (6' 10")
	Length (C)(1)(2)	2.72m (8' 11")	3.00m (9' 10")
	Overall Height (D) (1)(2)	1.19m (3' 4")	
	Deck Height (underside to skid) (E) (1)(2)	0.31m (1' 1")	
	Wheel Arms	Multi-position, manual adjustable	
	Tailwheels	1	
Gearbox	Lubricant	85W-140	
	Oil Capacity	4.30 litres (9.09 pints)	
Blades	12mm (quantity)	3	
	Tip Speed	85mps (16732 fpm)	87mps (17126 fpm)
Cutting Capacity	Height (2)	32mm-290mm (1 1/4" – 11 7/16")	
	Diameter (1)	100mm (4")	
Driveline	Approval	ASAE Category 4	
	Protection	2 plate slip clutch on input PTO driveshaft	

**Table 1.2 – Multicut 160/200 Standard Specification**

**Notes:**

- (1) Spearhead constantly reviews and improves product designs and reserve the right to change this information. Actual machines may vary from the above specification. Contact your Spearhead Sales representative if you have any queries.
- (2) All dimensions are determined from computer models, so actual measurements may vary slightly.

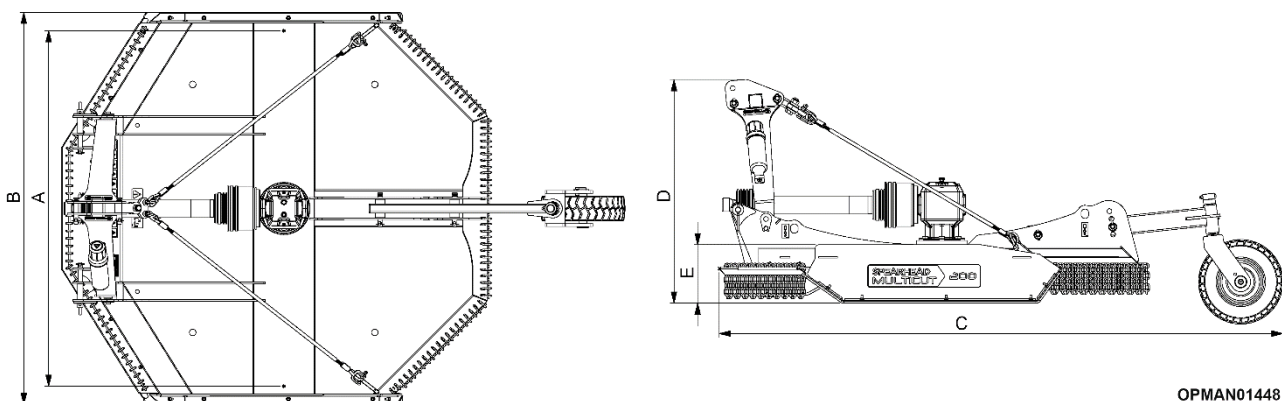



**Figure 1.7**

OPMAN01448

**NOTE:** These illustrations for working and transport dimensions are illustrated by a Multicut 200 for visual purposes only.

## 1.5.2 Machine Options

Multicut machines can be ordered in a variety of different specifications to fit the particular user's requirements.

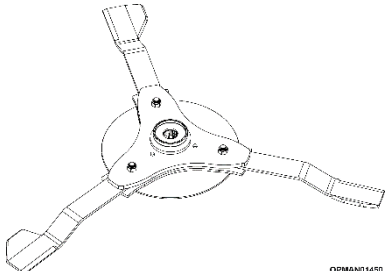
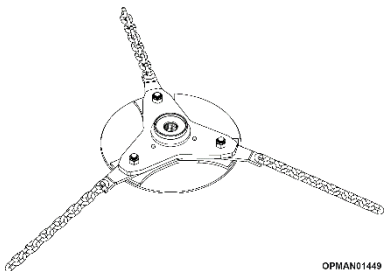
Option	Picture	
1.5.2.1 Input PTO Shaft	 <p style="text-align: center;">6 Spline</p>	 <p style="text-align: center;">21 Spline</p>
Option	Picture	
1.5.2.2 Blade Carrier	 <p style="text-align: center;">Standard Dual Blades</p>	 <p style="text-align: center;">Option Chains</p>

(This page is left blank intentionally)

## 2 Safety

### 2.1 Level Of Danger

The operator must read, understand and follow all of the Safety instructions. Serious injury or death may occur unless care is taken to follow the warnings and instructions provided. The level of safety is indicated in three levels and the following notation is used throughout this operator instruction book;



**DANGER!** Level 1; alerts for imminent death or critical injury.



**WARNING!** Level 2; warns of serious injury or possible death.



**CAUTION!** Level 3; indicates possible injury.

**IMPORTANT:** Special instruction related to either the machine, tractor or the working environment

**NOTE:** Special instruction related to either the machine, tractor or the working environment

### 2.2 Terminology

The indicated levels of danger refer to specific risk situation that may occur during machine use and may involve the same machine, the operator and any exposed persons. With the purpose of highlighting situations or operations that may result in risks, the meanings of terms used in this manual are indicated here:

- **WORKING ZONE:** Any area in and/or around a machine where the presence of an exposed person constitutes a risk to the health and safety of said person.
- **BYSTANDER:** A person fully or partly in a hazardous area.
- **OPERATOR:** The person or personnel in charge of the installation, the operation, the adjusting, the cleaning, the repairing and the moving of the machine.
- **USER:** the person, entity or company, who purchased or rented the machine and intends to use it according to the intended use foreseen by the manufacturer.
- **SPECIALISED PERSONNEL:** any person specifically trained and approved to carry out maintenance or repair interventions that require particular knowledge of the machine, its operation, the installed safety devices, intervention modes. It must be capable of recognising danger present on the actual machine, therefore avoiding at risk situations.
- **RISK:** a combination of the probability and seriousness of injury or damage to health which can arise in a dangerous situation.
- **GUARD:** a part of the machine that is used to specifically guarantee protection by way of a material barrier.
- **PROTECTION DEVICE:** a device that reduces risk (unlike the guard) either on its own or together with the guard.
- **INTENDED USE:** the use of the machine in accordance with the information provided in the operators manual.
- **REASONABLE FORESEEABLE MISUSE:** the use of the machine different to the information provided in the operator's instructions, which may be the result of readily predictable human behaviour.
- **GENUINE SPEARHEAD DEALER/ AUTHORIZED TRACTOR DEALER:** The Genuine Spearhead Dealer/ Authorized Tractor Dealer, legally authorised by the Manufacturer, is formed by specialised staff able to carry out all types of assistance, maintenance and repair work, even of a certain complexity, required to maintain the machine in perfect working order.



**WARNING!** Carefully read the guidance as stated in this manual relating to safe use. If the instructions described are not followed, a situation may arise which causes irreparable damage to the machine or property, or injury - even severe - to people or animals. Spearhead declines all responsibility for damage caused by not complying with the safety and injury prevention regulations described below. Spearhead also declines any responsibility for damage caused by improper use of the machine and/or as a result of modifications made without prior authorisation by the manufacturer.



## 2.3 Safe Use



**DANGER!** It is prohibited to use the machine in ways that are different from the indications contained in this operators manual.

Never operate the tractor or machinery until you have read and completely understood this manual and the tractor operator's and each of the safety messages given and those displayed on the tractor or implement.

Safety is of utmost importance to the manufacturer and should be of the same level of importance for the operator/owner. Spearhead machines have been designed to ensure the greatest level of protection to operating personnel and bystanders. However, in practice implementing the safety as guided in this operator manual is up to **you**. Only **you** can prevent serious injury or death from unsafe practices.

### 2.3.1 Health and Safety Executive (HSE) Guide Sheets

In Great Britain, it is important to take note of the health and safety guidance given by the Health and Safety Executive (HSE) with regards to safely operating agricultural machinery safely in addition to the safety guidance given in this rotary mower operator's manual and the tractor operator's manuals.

Health and Safety Executive (HSE) – Power take-offs and power take-off drive shafts (guide sheet)  
<https://www.hse.gov.uk/pubns/ais40.pdf>

Health and Safety Executive (HSE) – Safe use of agricultural mowers (guide sheet)  
<https://www.hse.gov.uk/pubns/ais25.pdf>

Health and Safety Executive (HSE) – Working safely with agricultural machinery (guide sheet)  
<https://www.hse.gov.uk/pubns/INDG241.pdf>

Health and Safety Executive (HSE) – Using tractors safely (guide sheet)  
<https://www.hse.gov.uk/pubns/indg185.pdf>

It is important for personnel and operators to follow the guidance and requirements of local and national health and safety laws and regulations of where the works are being carried out. Contact the governing body of the local jurisdiction to obtain detailed information on the subject to ensure that the works are being carried out correctly and safely.

### 2.3.2 Health and Safety Executive (HSE) Safe Stop Campaign

In Great Britain, Spearhead Machinery endorses the "Safe Stop" campaign promoted by the Health and Safety Executive (HSE) to give guidance on how to safely prepare the machine and personnel and operate the machine and what to do in emergency cases.

The 'Safe Stop' campaign focusses on the importance of following the 'Safe Stop' procedure:

- Engage handbrake
- Controls in neutral
- Switch off engine
- Remove key

<https://www.hse.gov.uk/agriculture/topics/machinery/safe-use-1.htm>



Figure 2.1

It is important for personnel and operators to follow the guidance and requirements of local and national health and safety laws and regulations of where the works are being carried out. Contact the governing body of the local jurisdiction to obtain detailed information on the subject to ensure that the works are being carried out correctly and safely.

### 2.3.3 Operators Manual



2.3.3.1 **IMPORTANT:** Read, understand and follow the safety messages stated throughout this section and the rest of this operator's manual. Serious injury or death may occur unless care is taken to follow the warnings.



2.3.3.2 **IMPORTANT:** Ensure the operator's manual is complete, readable, and easily accessed by the operator and accompanying personnel. If in doubt replace, by contacting your local Spearhead dealer or Spearhead Machinery directly.



2.3.3.3 **DANGER!** It is prohibited to use the machine in ways that are different from the indications contained in this operators manual.



2.3.3.4 **IMPORTANT:** Read the input PTO driveshaft operator's manual before using the machine.



2.3.3.5 **IMPORTANT:** It is required that all operators and personnel carrying out maintenance on this machine familiarise themselves with the machine and this operator manual to ensure they are aware of the dangers of incorrect use or improper or incorrect repairs.



2.3.3.6 **IMPORTANT:** If the operator cannot read the manuals for themselves or does not completely understand the operation of the equipment, it is the responsibility of the supervisor to read and explain the manuals, safety practices and operating instructions to the operator.

### 2.3.4 Personnel Preparation



2.3.4.1 **DANGER!** It is prohibited to use or have the machine used by personnel that are incompetent and not properly trained in the use of the tractor and machine controls and who are in poor health and physical condition or under the use of drugs or alcohol.



2.3.4.2 **IMPORTANT:** Ensure that the operator is aware of the correct emergency stop procedure if the tractor and machine is required to stop suddenly.



2.3.4.3 **DANGER!** It is forbidden to drive the agricultural tractor attached to the machine or have it driven by personnel without an appropriate driving licence.



2.3.4.4 **CAUTION!** It is mandatory to use suitable clothing; PPE for example. Strictly avoid long or loose clothing that could be caught in any way by moving parts. Wear suitable helmets, glasses, gloves, footwear, etc.



2.3.4.5 **WARNING!** When operating the machine do not wear loose or trailing clothing which may become snagged or entangled in moving parts.



2.3.4.6 **CAUTION!** Wear suitable clothing and PPE to cater for the working environment. In some geographical locations, wildlife such as bees or insects or larger wildlife could impact the wellbeing of the operator, machine and other bystanders. Inspect the work location before commencing work.



2.3.4.7 **CAUTION!** Ensure maintenance personnel wear suitable PPE clothing when maintaining the machine to ensure a reduced risk of impact or skin injuries. Frequent or prolonged contact with hydraulic oil may cause dermatitis and other skin disorders including (more rarely) skin cancer when not wearing impenetrable gloves. Worn parts may have sharp edges.

Follow the guidance of the lubricant manufacturer with regards to handling oils, solvents, cleansers and other chemical agents.



2.3.4.8 **IMPORTANT:** It is required that all operators and personnel carrying out maintenance on this machine familiarise themselves with the machine and this operator manual to ensure they are aware of the dangers of incorrect use or improper or incorrect repairs.



2.3.4.9 **CAUTION!** If the agricultural tractor has no closed cabin, the operator is required to use extra Personal Protection Equipment. Ear protectors are required and a dust mask if the working ground lifts a considerable amount of dust along with safety glasses. If your health is compromised during work or afterwards, stop immediately and seek professional medical advice immediately.



2.3.4.10 **DANGER!** Ensure you never smoke or have an open flame near the tractor or machine.



2.3.4.11 **CAUTION!** Personnel should take regular breaks during work to minimise fatigue and ensure alertness in work.



2.3.4.12 **IMPORTANT:** Personnel and operators should make themselves aware of local and national highway laws and regulations and contact the Department of Transport of your Local Highway Authority to obtain detailed information on the subject.



2.3.4.13 **IMPORTANT:** Personnel and operators should make themselves aware of local and national laws and regulations where they can and cannot carry out works with regards to wildlife and habitats.



2.3.4.14 **IMPORTANT:** Ensure a full risk assessment of the work site is conducted by a qualified body before beginning the works evaluating risks to the operator, machine, bystanders and other road users if applicable.



2.3.4.15 **IMPORTANT:** If the operator cannot read the manuals for themselves or does not completely understand the operation of the equipment, it is the responsibility of the supervisor to read and explain the manuals, safety practices and operating instructions to the operator.

## 2.3.5 Tractor And Machine Preparation For Work

### Tractor Preparation



2.3.5.1 **IMPORTANT:** Before starting, safety checks on tractor and machine must be carried out with regard to functionality, road safety and accident prevention rules.



2.3.5.2 **CAUTION!** Check that the agricultural tractor on which the machine is installed is of adequate power, weight and configuration, compatible with the model fitted and fitted with a seat belt.

The tractor should exceed the weight of the machine by at least 20%. For machine weights see Section 1.5.



- 2.3.5.3 **CAUTION!** Before proceeding to take the machine into the work area ensure that driving vision is not impaired by tractor, cab or implement for clear vision of ground hazards and bystanders while seated in the driver's seat.

Adjust rear view mirrors in order to see clearly the machine and all items behind.



- 2.3.5.4 **CAUTION!** Where a machine is used in conjunction with tractors not fitted with a glazed safety cab, a clear polycarbonate safety screen together with a mesh guard must be fitted to the tractor between the operator and the cutting unit. A polycarbonate safety screen must be used on cabs where windows are likely to be left open for ventilation purposes. It is essential that cab windows on the operating side, through which the machine is observed, are intact, clean and closed. Otherwise, a clear polycarbonate safety screen must be fitted where grass trimming operations are carried out.



- 2.3.5.5 **CAUTION!** If the agricultural tractor has no closed cabin, the tractor must be equipped with a "Rollover Protection Structure" (ROPS) which must always be locked in position.



- 2.3.5.6 **CAUTION!** Ensure that the tractor destined to be used with the machine has a vertical escaping, bonnet mounted exhaust to reduce potential fire risk when the machine is in operation. If the tractor is equipped with a under frame exhaust seek a different tractor of use.



- 2.3.5.7 **CAUTION!** If two or more tractors/machines are being used in close proximity in the working area, enclosed cabs must be used.



- 2.3.5.8 **CAUTION!** Do not mount the machine with trucks or other vehicles on the public highway.



- 2.3.5.9 **IMPORTANT:** Ensure that permissible axle loads are not exceeded.



- 2.3.5.10 **IMPORTANT:** Ensure that the correct fire extinguisher is carried inside the tractor at all times and is easily accessible.



- 2.3.5.11 **IMPORTANT:** Before preceding to start work ensure that steering and braking give proper operation and are in good condition.



- 2.3.5.12 **IMPORTANT:** Before proceeding to take the machine onto the public highway ensure that all tractor brake lights and indicators are working correctly.



- 2.3.5.13 **IMPORTANT:** Ensure the tractor is fitted with flashing warning beacons and Slow Moving Vehicle (SMV) sign if required. Check the local jurisdiction to determine what requirements are required to be switched on and shown when the machine is working.



- 2.3.5.14 **IMPORTANT:** Before proceeding to take the machine onto the public highway ensure that the tractor tyres are clear of mud and dirt build up.

### Machine Fitting



- 2.3.5.15 **DANGER!** Ensure that the lower and top linkages are correctly engaged between the rotary mower and tractor.



- 2.3.5.16 **IMPORTANT:** Ensure the lower link chains are correctly fitted and adjusted between the tractor and rotary mower to ensure the rotary mower is secure.



- 2.3.5.17 **IMPORTANT:** The condition of the headstock wire ropes must be checked before fitting the tractor to the machine and they must be replaced if damaged or missing before proceeding to fit the machine.



- 2.3.5.18 **WARNING!** When moving the rotary mower not fitted to the tractor ensure the machine is lifted or moved using suitable equipment using the correct procedure described in the operators manual.

### Machine General Inspection



- 2.3.5.19 **CAUTION!** Ensure that the tractor and rotary mower are correctly inspected using their designated pre-delivery inspection (PDI) sheet before first use.



- 2.3.5.20 **WARNING!** Check all key components. Inspect and replace all damaged components with genuine Spearhead parts and ensure the machine is running correctly again before resuming cutting operations.



- 2.3.5.21 **IMPORTANT:** The condition of the headstock wire ropes must be checked before beginning daily work and they must be replaced if damaged or missing before proceeding to use the machine.



- 2.3.5.22 **IMPORTANT:** The condition of the blades/chains must be checked before beginning daily work and they must all be replaced if damaged or missing before proceeding to use the machine.



- 2.3.5.23 **IMPORTANT:** The condition of all guarding and safety chains must be checked before beginning daily work and they must all be replaced if damaged or missing before proceeding to use the machine.



- 2.3.5.24 **IMPORTANT:** Ensure that the wear skids specified and supplied with the machine are fitted to the machine. If not, replace. Prolonged use of the machine with no wear skids will cause permanent wear to the main deck fabrications.



- 2.3.5.25 **IMPORTANT:** Check the machine to ensure all safety and instruction decals are in position as stated in Section 2.5.2. Replace any missing or damaged decal prior to proceeding to use the machine by sourcing from a local Spearhead dealer.



- 2.3.5.26 **IMPORTANT:** Before returning the machine back to work ensure the machine has been thoroughly inspected and checked using the Machine Inspection Record; see Section 5.11.

Ensure that when the machine inspection is carried out that the machine is stationary and not running.

Where parts are broken, damaged and deemed not fit for use; replace with genuine Spearhead parts using the online Interactive Parts facility at:

<https://my.spearheadmachinery.com/parts/public-interactive-parts-database/>

You will require the machine serial number. Assistance to its location can be found in Section 1.3.

### Input PTO Driveshaft



- 2.3.5.27 **IMPORTANT:** It is mandatory to use the type of input PTO driveshaft supplied with the machine by Spearhead and for the same type to be sourced again when a replacement is required.



- 2.3.5.28 **IMPORTANT:** Ensure that before first use the input PTO driveshaft is the correct item for the tractor in which the machine is intended to be attached to and is prepared, greased and shortened to the correct length required following the guidance in the relevant section of the operators manual.

Spearhead does not accept returns on modified/prepared or used input PTO driveshafts, so please take extended time to ensure the item is correct and safe for the tractor application. See Section 3.3.



- 2.3.5.29 **IMPORTANT:** Do not use PTO adaptors on input PTO driveshafts. This can cause examples such as excessive vibration and driveline failures due to changes in the machines intended use.

PTO adaptors also increase the exposed working length of the PTO driveshaft increasing the probability of entanglement with external objects. If the driveshaft is incorrect for the tractor; request another driveshaft from your local Spearhead dealer.



2.3.5.30 **WARNING!** Never connect the power takeoff unless the tractor engine is stopped.



2.3.5.31 **IMPORTANT:** Do not connect the machine to a tractor with a PTO directly connected to the tractor transmission.



2.3.5.32 **DANGER!** At all times ensure that the PTO driveshaft guard is in position, securely fitted, in good condition and that the tractor PTO driveshaft shield is fitted.



2.3.5.33 **IMPORTANT:** Replace any of the PTO driveshaft or coupling guards if any of the following are evident; cracks or damages or any part of the PTO driveshaft is exposed. Ensure the PTO driveshaft guard is not free to rotate, and the anti-rotation chains are securely fitted and effective before starting the PTO.



2.3.5.34 **IMPORTANT:** Make sure that the maximum number of revolutions of the PTO is set to the specific specification of the particular machine in question; 540 rpm, before powering it. Over-speeding a driveline may result in driveline components and attachment. If in any doubt, contact your local Spearhead dealer or Spearhead directly.



2.3.5.35 **IMPORTANT:** Ensure that the clutch plates on the PTO shaft are free and set to the correct setting as stated in Section 5.4.3. This will avoid excessive slippage and clutch plate heating.

If the machine has been laid up for any length of time, there is a risk of the clutch plates rusting and seizing together. It is best practice to check clutch settings daily, even on a brand new machine to ensure that they are correct and to release clutches when the machine is being laid up for extended periods.

#### Fasteners



2.3.5.36 **IMPORTANT:** Periodically (every 8 hours) verify that the screws and bolts are tightened and secure.



2.3.5.37 **IMPORTANT:** Ensure that the specific torque settings of special fasteners are adhered to using the settings stated in the specific section of the operators manual.



2.3.5.38 **IMPORTANT:** Pay special attention to blade/chain bolts for their condition and ensure that they tightened to the specific torque setting required stated in the specific section of the operators manual.

#### Gearbox Oil And Lubrication



2.3.5.39 **IMPORTANT:** Using the types of lubricating oils indicated by Spearhead and follow the recommended guidelines of the lubricant manufacturer. Check oil levels and grease points daily to ensure the longevity of your components on your machine following the maintenance section of this operators manual.

Follow the guidance of the lubricant manufacturer with regards to handling oils, solvents, cleansers and other chemical agents.



2.3.5.40 **CAUTION!** Check the machine daily for gearbox oil leaks. If any component in the system is faulty, replace the component before proceeding to use the machine.



2.3.5.41 **CAUTION!** When working with/checking the gearbox on the machine always wear safety glasses and impenetrable gloves. Use paper or cardboard to search for leaks and not hands or any other body parts.



2.3.5.42 **CAUTION!** Keep hands and body away from pin holes and nozzles ejecting gearbox. Ingested or penetrated gearbox oil in the body can become gangrenous. Removal must be carried out professionally by a suitable Doctor.



2.3.5.43 **IMPORTANT:** Warm the gearbox oil of the rotary mower at idle speed before working at the correct 540rpm cutting speed. Forcing the rotary mower to work at high rpm using cold oil will lead to cavitation and permanent damage to driveline components.



2.3.5.44 **IMPORTANT:** Ensure that the specific torque settings of the gearbox fasteners are adhered to using the settings stated in the specific section of the operators manual.

### Guarding



2.3.5.45 **DANGER!** Do not operate the rotary mower with guards missing. Ensure that the correct guards are properly fitted to the machine and tractor at all times and that they are in good condition and function as they are intended to. If guards are missing; replace before using the machine.



2.3.5.46 **DANGER!** It is forbidden to alter, tamper with or bypass any of the components on the machine including the safety devices provided by the manufacturer. e.g. guarding.

Spearhead claims no responsibility to damages to operators, personnel or property by the factory fitted guards being not fitted or in poor repair.



2.3.5.47 **IMPORTANT:** The condition of all guards must be checked before beginning daily work and they must be replaced if damaged or missing before proceeding to use the machine.



2.3.5.48 **CAUTION!** Keep protection chains in position at all times. They are an essential part of the machines guarding. The machine must not be operated with any of the chains missing.

### Cleanliness



2.3.5.49 **WARNING!** It is forbidden to deposit items on the machine which can harm persons or animals, or damage property should they fall.



2.3.5.50 **CAUTION!** Check the machine daily for gearbox oil leaks. If any component in the system is faulty, replace the component before proceeding to use the machine.



2.3.5.51 **IMPORTANT:** Before proceeding to take the machine onto the public highway ensure that the rotary mower is clear of any cut material collected.



2.3.5.52 **IMPORTANT:** Before proceeding to take the machine onto the public highway ensure that the tractor tyres are clear of mud and dirt build up.

## 2.3.6 Work Site Preparation

### Risk



2.3.6.1 **IMPORTANT:** Ensure a full risk assessment of the work site is conducted by a qualified body before beginning the works evaluating risks to the operator, machine, bystanders and other road users if applicable.

### Land Geography



2.3.6.2 **WARNING!** Verify that the ground on which the tractor moves is level and sturdy, before using the machine.



- 2.3.6.3 **CAUTION!** Ensure the environment where the machine is required to operate has adequate lighting. Insufficient or excessive lighting may pose a risk to the operator or bystanders. Ensure you have at least 90m (300 ft) clear visibility ahead of you to identify passers-by and potential risks and disturbances to yourself and/or tractor/machine and ensure you have sufficient time to adjust/stop.

#### Hazards



- 2.3.6.4 **WARNING!** Extreme care should be taken when operating near loose objects such as gravel, rocks, wire, and other debris. Inspect the area before mowing. Foreign objects should be removed from the site prior to beginning work to prevent machine damage to the operator, bystanders or the environment. Any objects that cannot be removed must be clearly marked and carefully avoided by the operator.



- 2.3.6.5 **WARNING!** Inspect the work area for overhead or underground electrical power lines. Gas pipes, other cables and any other kind of structure which could be detrimental to the machine or create risk for operator/personnel/bystanders. These should be either removed, marked to keep away from or if preventative methods cannot be easily placed alternative methods of landscape maintenance should be considered.

If short buried utility lines are located; contact your local utility maintenance provider responsible for the work site and do not use the machine until the issue has been addressed and made safe.



- 2.3.6.6 **WARNING!** In overgrown or high grass before proceeding inspect for, remove or mark potential hazards and mow at an **intermediate** height. Then repeat the process of inspection and hazard prevention and mow at the required **finished** height. Increased work site observation will be required to maintain safety through the mowing operation.



- 2.3.6.7 **WARNING!** Ensure that there are no fire sources present or near the destined working area of the machine. Do not drive into burning debris if it is present or if the area is freshly burnt out.

#### Public Bystanders



- 2.3.6.8 **IMPORTANT:** Ensure that before out carrying out work procedures that the working zone is correctly prepared if applicable to warn bystanders and road users of the works being carried out and how they should act as a response.

If applicable, the working zone should be prepared with:

- Grass cutting warning signs to warn bystanders and road users that the works are being carried out.
- One lane only signs to warn road users of one lane being occupied potentially by the working machine.
- Hold left/right signs (depending on the direction of travel of traffic) to direct road users of the correct way to pass by the working machine.



- 2.3.6.9 **IMPORTANT:** Ensure that all warning signs are moved at the same speed as the works are being carried out.



- 2.3.6.10 **IMPORTANT:** Carry out work during non-disruptive work hours. Outside rush hour.



- 2.3.6.11 **IMPORTANT:** Debris material must be collected or swept away from the working zone once the works have been carried out.



## 2.3.7 Machine At Work & Observation

### Operator Conduct



2.3.7.1 **WARNING!** All operation related to the tractor and machine should always be carried out from the driver's seat with seat belt buckled whether working or transporting the machine on the public highway.



2.3.7.2 **WARNING!** It is forbidden to abandon the driver's seat on the agricultural tractor with the combustion engine running when the machine is running. The machine should always be monitored from the cab of the tractor.



2.3.7.3 **WARNING!** Never approach the machine or leave the tractors seat until the rotor has completely stopped, and the tractor has been stopped using the "Safe Stop" procedure.



2.3.7.4 **CAUTION!** Personnel should take regular breaks during work to minimise fatigue and ensure alertness in work.



2.3.7.5 **DANGER!** Do not enter the working zone of the PTO shaft when the machine and tractor are running. It is dangerous to approach the rotating parts of the machine.



2.3.7.6 **WARNING!** Never carry passengers in the tractor unless it is fitted with an approved seat and seat belt.



2.3.7.7 **WARNING!** Never carry passengers on the machine.

### Working Procedure



2.3.7.8 **WARNING!** Adjust the mower deck so its close and parallel to the ground to ensure that the blades/chains are not exposed when the machine is being operated.



2.3.7.9 **WARNING!** Keep your forward speed to a level appropriate to the operating conditions. High-speed manoeuvres are very dangerous, particularly on uneven ground where there is risk of overturning. Reduce speed in poor towing conditions.



2.3.7.10 **WARNING!** Never operate the machine with the rotor moving in raised position, even for short distances.



2.3.7.11 **IMPORTANT:** Do not exceed the mowers rated cutting capacity and use the machine to cut any non-intended material. See Sections 1.5.1.

If the overgrowth required by the machine to be cut is greater than the machines maximum cutting capacity, use **intermediate stages** of cutting in order to ensure the wellbeing of the machine and reduce hazardous risks to operator and bystanders **before the final cutting height is achieved.**



2.3.7.12 **WARNING!** Avoid mowing in reverse with the PTO engaged. Disengage the mower and raise the machine then reverse. Then lower the machine, engage PTO and drive forward again.



2.3.7.13 **CAUTION!** Rotor gearboxes can become very hot when in work. Ensure that the gearbox is sufficiently cool before going anywhere near the gearbox.



2.3.7.14 **CAUTION!** Ensure that the deck of the machine is clear of excess debris. Rotor gearboxes and other driveline components can become hugely hot when in work and debris could cause risk of a fire hazard.



2.3.7.15 **WARNING!** Pay special attention when working with the machine and do not allow the machine to touch fixed objects such as road drains, walls, shafts, curbs, guard rails, tracks etc. as these could break the blades/chains which could cause debris to be thrown at very high speed from the machine. A fire hazard could be created in contacting objects as well. As a

precaution raise the cutting height of the machine to ensure they do not collide when the machine is in work.



- 2.3.7.16 **DANGER!** **Avoid wire.** It can be extremely dangerous if wire catches in the rotor, and every care must be taken to ensure this will not happen. Inspect the working area before commencing.



- 2.3.7.17 **WARNING!** Check all key components including blades/chains, blade/chains carriers and anti-scalp dishes. Blades/chains can fail from impact and objects can be thrown at great velocity. Inspect and replace all damaged components with genuine Spearhead parts and ensure the machine is running correctly again before resuming cutting operations.

Stop mowing immediately if blades/chains strike a foreign object.



- 2.3.7.18 **WARNING!** Do not mow in standing water to avoid possible blade/chain failure.



- 2.3.7.19 **IMPORTANT:** Stop and do not use the machine when there is vibration in the machine, as this may cause breakage and extended serious damage. Find the cause of the vibration or have it inspected by your local Spearhead dealer and do not use the machine until the cause is identified and eliminated.



- 2.3.7.20 **IMPORTANT:** During work you may be required to adjust your mowing speed to compensate for changes in terrain such as slopes, grass type and density and depending on the cut height you desire to achieve. You should also adjust your speed to compensate for external factors such as overhead obstructions and debris/foreign objects.



- 2.3.7.21 **WARNING!** Failure to have sufficient load over the front axle (20% +) or to drive at inappropriate speeds on undulating terrain may result in a loss of directional control.



- 2.3.7.22 **IMPORTANT:** Make sure that the maximum number of revolutions of the PTO is set to the specific specification of the particular machine in question; 540 rpm, before powering it. Over-speeding a driveline may result in driveline components and attachment. If in any doubt, contact your local Spearhead dealer or Spearhead directly.



- 2.3.7.23 **WARNING!** During work, if the tractor requires refuelling ensure the machine is stopped and halted using the "Safe Stop" procedure.

#### Bystander Observation



- 2.3.7.24 **DANGER!** When lowering the machine ensure bystanders stay clear to avoid crushing.



- 2.3.7.25 **DANGER!** It is forbidden to approach, stand close or touch the machine when the machine is running. It is the operators responsibility to check before starting up the machine and during work that bystanders who may inadvertently get in the way of cut material being thrown are kept away from the tractor and machine. Machines are capable under adverse conditions of throwing objects great distances at high velocity. Stop the rotors until all bystanders are well clear (90 m/300 ft+).









- 2.3.7.26 **WARNING!** While the tractor is running all personnel should keep well clear of the area around the machine (90m/300 ft+) as there are numerous crushing, shearing, impact dangers caused by the machine operation.













- 2.3.7.27 **WARNING!** Use constant observation of nearby bystanders. Road users and other members of the public may not see the risk of the machine. If a potential risk is possible for the machine or other bystanders; safely stop the machine! Evaluate the situation and begin work again once the risk has been assessed.

## 2.3.8 Transporting The Machine

### Operator Conduct

-  2.3.8.1 **WARNING!** All operation related to the tractor and machine should always be carried out from the driver's seat with seat belt buckled whether working or transporting the machine on the public highway.
-  2.3.8.2 **WARNING!** It is forbidden to abandon the driver's seat on the agricultural tractor with the combustion engine running when the machine is running. The machine should always be monitored from the cab of the tractor.
-  2.3.8.3 **CAUTION!** Personnel should take regular breaks during work to minimise fatigue and ensure alertness in work.
-  2.3.8.4 **WARNING!** Never carry passengers in the tractor unless it is fitted with an approved seat and seat belt.
-  2.3.8.5 **WARNING!** Never carry passengers on the machine.
-  2.3.8.6 **IMPORTANT:** When driving on public roads respect other road users and obey the highway laws of the local jurisdiction.

### Transport Procedure

-  2.3.8.7 **WARNING!** Ensure that the rotor has completely stopped before raising the machine from working position.
-  2.3.8.8 **WARNING!** Never operate the machine with the rotor moving in the raised position, even for short distances.
-  2.3.8.9 **DANGER!** When transporting the machine do not engage the tractor PTO.
-  2.3.8.10 **DANGER!** When transporting the machine with the machine raised (transport position), ensure that there is sufficient ground clearance below the machine to make sure the machine doesn't bottom when travelling along uneven terrain, such as speed humps.
-  2.3.8.11 **WARNING!** Check that the levers/buttons which operate the hydraulic lift are locked into position, to avoid the machine lowering during transport.
-  2.3.8.12 **IMPORTANT:** The tractor and machine will respond different between working and transport position. A machine in transport position will have a higher centre of gravity so will be more likely to make the tractor and machine unstable at lower speeds. The operator is required to adjust their driving characteristics/speed in order to ensure safety to bystanders and other vehicles.
-  2.3.8.13 **WARNING!** Failure to have sufficient load over the front axle (20% +) or to drive at inappropriate speeds on undulating terrain may result in a loss of directional control.
-  2.3.8.14 **IMPORTANT:** Use low speeds and smooth, gradual steering action in order to ensure safety to bystanders and other vehicles when on curves, hills, rough or uneven surfaces or wet roads.
-  2.3.8.15 **IMPORTANT:** Allow clearance for implement swing while turning.
-  2.3.8.16 **IMPORTANT:** Before proceeding to take the machine onto the public highway ensure that the machine deck is clear of any cut material collected.
-  2.3.8.17 **IMPORTANT:** Before proceeding to take the machine onto the public highway ensure that the tractor and machine tyres are clear of mud and dirt build up.



2.3.8.18 **IMPORTANT:** Ensure the tractor is fitted with flashing warning beacons and they are switched on, if required. Contact the local jurisdiction authority for guidance on machine preparation.



2.3.8.19 **WARNING!** Transport the machine only at safe speeds and at a maximum speed of 20 mph (32 kph). Serious accidents and injuries can result from operating or transporting this equipment at unsafe speeds. Drive for the conditions and reduce speed if required.

### 2.3.9 Machine Storage



2.3.9.1 **WARNING!** It is mandatory to stop the tractor and use the “Safe Stop” procedure before leaving the driver’s seat. Only mount or dismount the tractor when machine/tractor are at standstill and stopped.



2.3.9.2 **CAUTION!** When the machine is not in use, ensure the machine is supported on a level ground to ensure the machine will not move.



2.3.9.3 **CAUTION!** When the machine is not in use and not connected to a tractor, use chocks in order to ensure the machine is secure and will not move.



2.3.9.4 **IMPORTANT:** Store the machine in a safe place which is protected from the elements, to ensure its wellbeing and protection from damage to components for when the machine is to be recommissioned and used again.

## 2.4 Safe Maintenance

### Location



2.4.1.1 **WARNING!** It is mandatory to stop the tractor and use the “Safe Stop” procedure before engaging in maintenance operations.



2.4.1.2 **DANGER!** Disconnect the PTO shaft connecting the gearbox of the machine to the tractor PTO before starting any maintenance or adjustment.



2.4.1.3 **WARNING!** It is mandatory for the machine to be lifted adequately and with suitable lifting accessories and harness in the positions as stated in Section 3.1 and according to the regulations in force in the country where these operations take place along with the recommendations of Spearhead.



2.4.1.4 **DANGER!** When raising the machine make sure that personnel are distanced from the machine to ensure they are not hit by falling components; for example swinging blades.



2.4.1.5 **IMPORTANT:** Store the machine in a safe place which is protected from the elements, when the work is completed to ensure its wellbeing and protection from damage to components.

### Personnel



2.4.1.6 **IMPORTANT:** Maintenance on the machine should be performed by only skilled and specialized personnel, in strict compliance with the instructions in this manual, and any worn or damaged parts should be replaced.



2.4.1.7 **CAUTION!** When working with/checking the driveline on the machine always wear safety glasses and impenetrable gloves. This applies to working with gearboxes and gearbox oil. Use paper or cardboard to search for leaks and not hands or any other body parts.



2.4.1.8 **CAUTION!** Ensure maintenance personnel wear suitable PPE clothing when maintaining the machine to ensure a reduced risk of impact or skin injuries. Frequent or prolonged contact with oil may cause dermatitis and other skin disorders including (more rarely) skin cancer when not wearing impenetrable gloves. Worn parts may have sharp edges.

Follow the guidance of the lubricant manufacturer with regards to handling oils, solvents, cleansers and other chemical agents.



- 2.4.1.9 **CAUTION!** Keep hands and body away from pin holes and nozzles ejecting gearbox oil. Ingested or penetrated oil in the body can become gangrenous. Removal must be carried out by a medical professional.



- 2.4.1.10 **CAUTION!** Always wear protective gloves when handling blades, chains, knives, cuttings edges or worn components with sharp edges.



- 2.4.1.11 **CAUTION!** Components such as rotor gearboxes can become hugely hot when in work. Ensure that the gearbox is sufficiently cool before going anywhere near these components for maintenance. As a precaution though wear gloves and safety glasses when servicing these potentially hot items or any other potentially hot item on the machine.



- 2.4.1.12 **DANGER!** Engine exhaust fumes and some of their constituents and certain vehicle components contain or emit chemicals known to the state of California to cause cancer, birth defects or other reproductive harm. See Section 2.10 with regards to Proposition 65.

### Parts & Components



- 2.4.1.13 **IMPORTANT:** Always use genuine Spearhead parts when carrying out repairs and maintenance with thoughts to longevity and reliability of the machine and personnel safety.



- 2.4.1.14 **IMPORTANT:** Do not modify or alter implement functions or components.



- 2.4.1.15 **DANGER!** Do not weld or repair rotating mower components such as blade/chain carriers and blades/chains. They may cause vibrations and component failures being thrown from the machine.



- 2.4.1.16 **DANGER!** Replace bent, damaged, cracked or broken blades/chains immediately with new blades/chains.

Do not attempt to straighten, weld or weld hard-facing blades/chains to avoid blade/chain failures and throw broken blades/chains from the machine.



- 2.4.1.17 **DANGER!** If the underside of the machine is required to be lifted to be worked on ensure that the machine is supported with solid stands. Not via an adjustable hydraulic jack or an overhead crane.



- 2.4.1.18 **DANGER!** If the machine is required to be worked on ensure that the ground is level, sturdy and solid and that the machine is suitably chocked in order to ensure it doesn't move or fall.



- 2.4.1.19 **DANGER!** Do not run the tractor engine inside. Only run the tractor in open outdoor spaces.



- 2.4.1.20 **IMPORTANT:** Always replace guards that have been removed for service or maintenance and ensure they are fit for use, give complete protection and work as intended. If not, replace them before proceeding to use the machine.



- 2.4.1.21 **CAUTION!** Ensure a good footing by standing on solid, flat surfaces when getting onto the machine to carry out work.



- 2.4.1.22 **CAUTION!** If maintenance is required on the machine in a location which is high up and inaccessible from the ground; use a secure ladder or raised stands.



- 2.4.1.23 **CAUTION!** Never use the PTO or PTO guards as a step.



- 2.4.1.24 **IMPORTANT:** Comply with the laws in force in the country of installation on the use and disposal of products used for cleaning and performing maintenance on the machine,

considering the recommendations of the manufacturer and local guidelines on the given products.



2.4.1.25 **IMPORTANT:** Before returning the machine back to work ensure the machine has been thoroughly checked over using the Machine Inspection Record; see Section 5.9.

Ensure that when the machine inspection is carried out that the machine is stationary and not running.

Where parts are broken, damaged and deemed not fit for use; replace with genuine Spearhead parts using the online Interactive Parts facility at:

<https://my.spearheadmachinery.com/parts/public-interactive-parts-database/>

You will require the machine serial number. Assistance to its location can be found in Section 1.3.

## 2.5 Safety & Operational Decals

Multicut machines are equipped with safety and operational decals warning about residual risks present on the machines that were not possible to eliminate. Some give guidance in how to best operate and care for the machine. Safety decals are yellow in colour and placed in strategic positions around each of the respective dangers. Operational decals are generally white in colour and are placed in locations close to the respective item required to be maintained. Section 2.5.1 specifies the meaning of each of the symbols contained in the decals and their particular positioning on the machine is stated in Section 2.5.2. The operator must memorise the meaning of these decals.

All decals should be kept clean and replaced immediately if they are fully/partially detached or damaged by purchasing them through a local Spearhead dealer.

### 2.5.1 Definitions

1

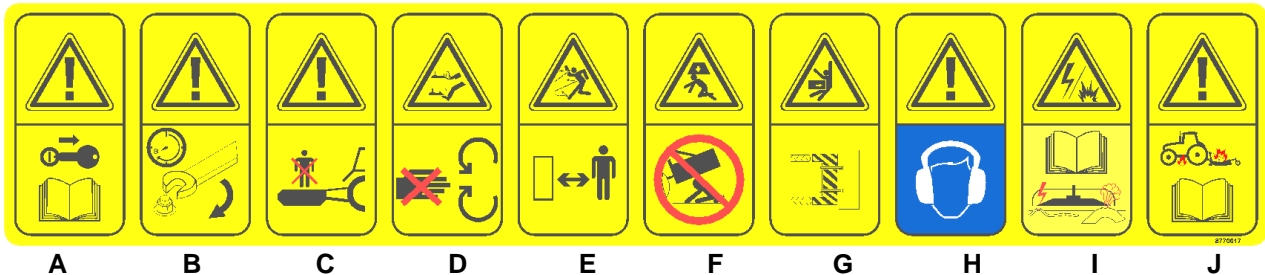
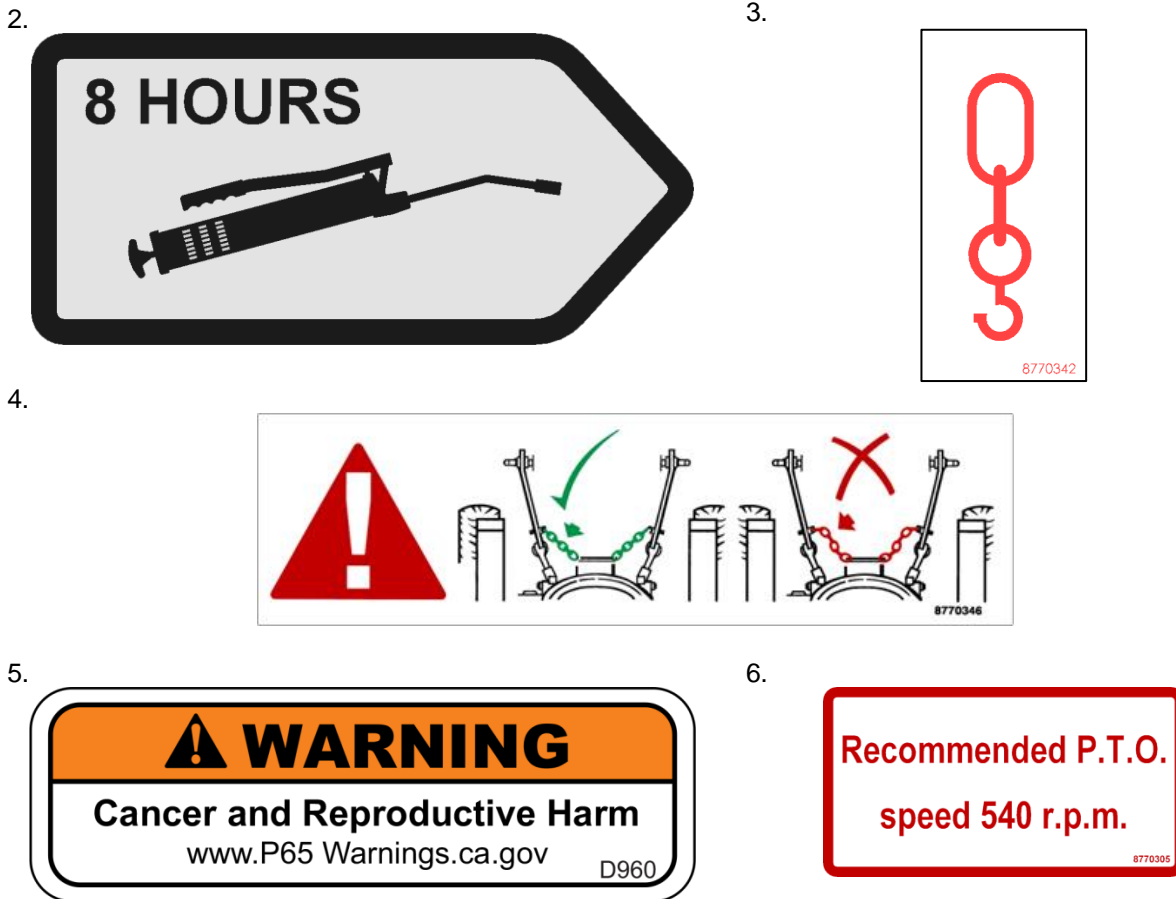

Figure 2.2 – 8770617 Safety Decal

a	Warning: - Remove key, read instruction manual	The original machine operators manual should be read before using the machine giving guidance to operation and maintenance
b	Instruction: - Check the tightness of fasteners	The tightness of all fasteners around the machine should be checked at least once every 8 hours
c	Danger: - Do not stand ride on the machine	The machine should be at no point be ridden on; whether in transport or during work
d	Danger: - Cutting hazard from rotating blades/chains	Personnel should keep at distance from the machine when the machine is operating
e	Danger: - Flying debris	Personnel should keep at distance from the machine when the machine is operating due to the risk of items being flung from the machine
f	Danger: - Crushing hazard if unsupported	Personnel should keep at distance from the machine when the machine is unsupported as of the risk of the wing and other items falling posing potential entrapment or crushing
g	Danger: - Operating area hazard	Personnel should keep at distance from the machine when the in operation as of the risk of entanglement or crushing by components
h	Danger: - Wear ear protection	Personnel should wear hearing protection when in close proximity to the machine in operation to prevent permanent hearing damage
i	Warning/Instruction: - Explosion hazard	Check the working site before proceeding to use the machine.
j	Warning/Instruction: - Clear deck of debris	It is important to ensure that the machine decks are clear of debris to stop the risk of fire. Never drive over fire with the tractor and machine.

Table 2.1 – 8770617 Safety Decal Definitions



**Figure 2.3 – Other Safety & Instruction Decals**

2	Instruction: - Grease every 8 hours	Placed and pointed towards components of the machine which should be greased at least once every 8 hours.
3	Instruction: - Designated lifting point	Placed at positions on machine where safe lifting should be carried out.
4	Instruction: - Keep chains tight	Ensure that the tractor lower link chains are of a sufficient length to ensure that they are kept tight at all times when the rotary mower is fitted.
5	Instruction: - P65 cancer and reproductive harm	Operating, servicing and maintaining this equipment can expose you to chemicals which are known to the State of California to cause cancer and birth defects or other reproductive harm.
6	Warning/Instruction: - PTO operating speed	Indication to the correct operating speed of the machine when in work. 540 RPM.

**Table 2.2 – Other Safety & Instruction Decal Definitions**

For the placement of these decals on each of these machines, please refer to Section 2.5.2.



## 2.5.2 Placement

Section 2.5.2.1 states the particular positions safety and instruction decals are placed on Multicut 160/200 machines.

### 2.5.2.1 Multicut 160/200

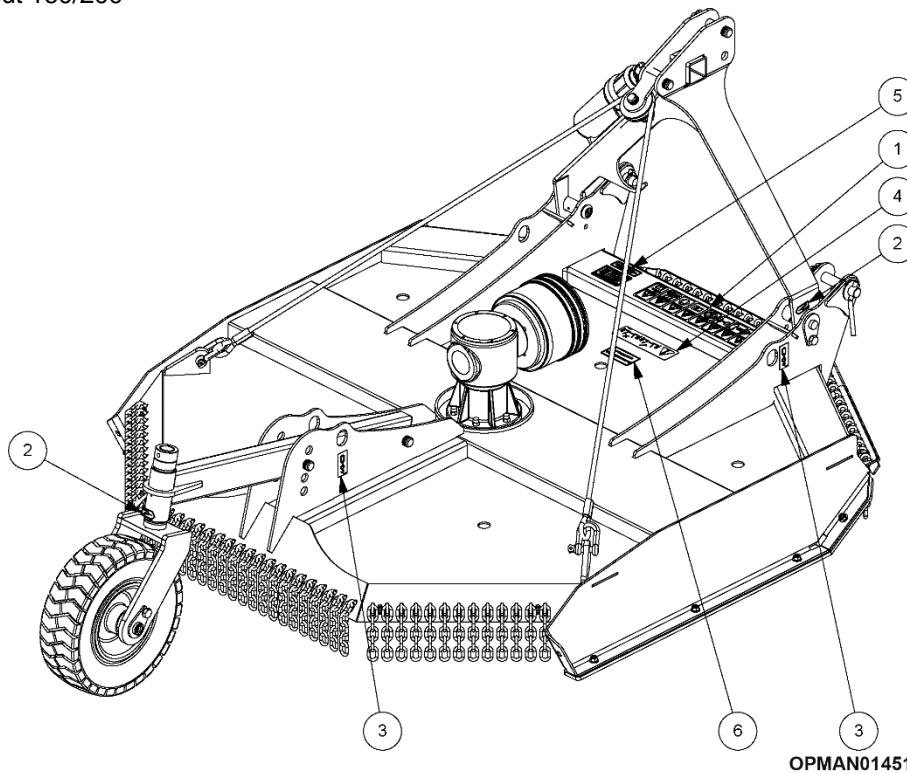

**Figure 2.4 – Multicut 160/200 Safety & Instructional Decal Placement**

## 2.5.3 Replacement

It is of utmost importance that safety decals are kept clean and replaced if they are no longer legible, damaged or lost completely. Safety decals can be purchased readily from a local Spearhead dealer.

Spearhead safety decals have the replacement part number found in the bottom right of the decals.

For more extensive guidance on ordering spare parts and how to go about finding the correct part number; see Section 7.

## 2.6 Guards



**DANGER!** For safe operation it is essential that that all guards and the protection chains must be kept in position on the machine whenever the machine is running. Spearhead disclaim all responsibility for any damage or injury arising as a result of guards or protection chains being removed, guards other than of Spearhead manufacture being fitted, or of operation of the machine other than in accordance with these instructions.



**WARNING!** Inspect guards twice daily or immediately damage is suspected.

Always replace guards that have damage or wear which could impair their performance. Typical damage to inspect for is as follows;

<b>Drive guard and side skids</b>	Distorted or with sharp outer edges, exposed openings
<b>PTO guards</b>	Cracked, missing portions revealing moving parts
<b>Chain guards</b>	Missing chain lengths to permit stones or similar objects to be ejected beneath it in normal conditions

**Table 2.3 – Permanent Protection Guard Damages**

### 2.6.1 Mandatory Guards

The General arrangement figure found in Section 1.2 and the list below show the mandatory guards required. These along with the danger decals and warning decals are necessary for safe cutting operations with this machine;

- Driveline guard
- PTO shaft guard
- Front metal chain guards
- Rear metal chain guards

## 2.7 Sound

The air noise level created by the machine under operating conditions was detected using a sound level meter with integrator.

The measurements were carried out in accordance with ISO 1680-2 with the machine. Tests performed under the conditions indicated by the standard produced the following results:

Machine	Tractor With Open Cab	Tractor With Closed Cab
<b>Multicut 160</b>	TBC	TBC
<b>Multicut 200</b>	TBC	TBC

**Table 2.4 – Multicut Sound Readings**

## 2.8 Personal Protective Equipment

Operators should be wearing sufficient personal protection equipment (PPE) to protect them from hearing, respiratory and impact damages.

When working in an unsealed cab or where windows and apertures are open to the environment, operators are advised to wear suitable eye and ear protection, a facemask (depending on conditions) and eye protection.

When handling cutting surfaces or hydraulic equipment, operators are advised to wear suitable gloves.

When clearing blockages, clearing wire, or working with pressurised hydraulic components, operators are advised to wear suitable eye protection and suitable gloves.

Ensure that non-baggy clothing is worn to reduce the chance of entanglement and snagging on components.



OPMAN00161

**Figure 2.5- PPE Items**

When working at the work site, but off the tractor unit, operators are advised to wear a 'high-viz' garment.

## 2.9 The Machine & The Environment

Below are the minimum provisions to be followed in order to reduce the risk of environmental impact connected to the use of the machine:

- If the Country where the machine is used foresees specific sound emission limits, it is best to adapt to the provisions in these standards, if necessary, being supplied with suitable protective equipment (earplugs, muffs, etc.).
- **It is mandatory** to respect current legislation of the Country where the machine is used, related to use and disposal of lubricants and products used for machine cleaning and maintenance, observing the recommendations of the manufacturer of those products.
- If replacing worn parts or during demolition, one must follow anti-pollution laws foreseen in the country where the machine is used.
- **It is prohibited** to pour products used for cleaning or polluting substances into the sewerage drain, on the ground, in watercourses, or into the environment.
- **It is mandatory** to collect products used for cleaning and polluting substances in appropriate containers, store them and deliver them to companies authorised for their disposal.

### 2.9.1 Disposal

When Spearhead equipment reaches the end of its economic working life it should be disposed of responsibly, either through an approved recycling centre or by compliance with all regulations in force in the destination territory.

In most instances Spearhead machines can be broken into its constituent parts with the use of basic workshop equipment. Table contains a typical list of constituent materials, together with disposal guidelines.

When undertaking a machine breakdown, take care to ensure that heavy parts are always adequately supported to avoid injury.

To avoid environmental contamination, take containment precautions to retain control of liquids in order.

It is the owner's responsibility to ensure the machine is disposed of in accordance with all applicable regulations.

Material	Typically found in;	Disposal guideline
Steel	Structural components, fixed guards, fasteners and driveline	Can be dismantled and recycled. Take care when handling heavy and/or sharp objects
Aluminium	Pump and gearbox housings, serial number plates	Can be dismantled and recycled. Take care when handling heavy and/or sharp objects. Take appropriate actions for oil contaminated products
Copper	Wiring, electrical components	Can be recycled using appropriate recovery procedures.
Hydraulic oil	Tank, hydraulic components	Dispose of in accordance with all applicable regulations
Rubber	Hoses, flexible guards, seals, 'O' rings	Dispose of in accordance with all applicable regulations
Plastics	Clips, caps, cable ties, decals, filter housings, document holders, bushes, electrical components, plugs, connectors, wire insulation	Dispose of in accordance with all applicable regulations
Filter element	Filter housings	Dispose of in accordance with all applicable regulations
Cork / paper	Gaskets	Dispose of in accordance with all applicable regulations

**Table 2.5 – Machine Breakdown Component Disposal**

## 2.10 Proposition 65



**Figure 2.6 – P65 Cancer And Reproductive Harm Decal**

Operating, servicing and maintaining this equipment can expose you to chemicals including gasoline, diesel fuel, lubricants, petroleum products, engine exhaust, carbon monoxide, and phthalates, which are known to the State of California to cause cancer and birth defects or other reproductive harm.

To minimize exposure, avoid breathing exhaust, do not idle the engine except as necessary, service your vehicle in a well-ventilated area and wear gloves and wash your hands frequently when servicing your vehicle. Battery posts, terminals and related accessories contain lead and lead compounds, chemicals known to the state of California to cause cancer, birth defects or other reproductive harm.

For more information go to [www.P65Warnings.ca.gov](http://www.P65Warnings.ca.gov).

This website, operated by California's Office of Environmental Health Hazard Assessment, provides information about these chemicals and how individuals may be exposed to them.

(This page is left blank intentionally)

## 3 Machine Preparation

### 3.1 Lifting The Machine



**WARNING!** Do not lift by headstock alone. Damage may occur which will invalidate warranty. Use recommended lifting point locations.

Multicut 160/200 machines should be lifted using the four designated lifting loops in each of the four corners of the machine deck; as shown in Figure 3.1.

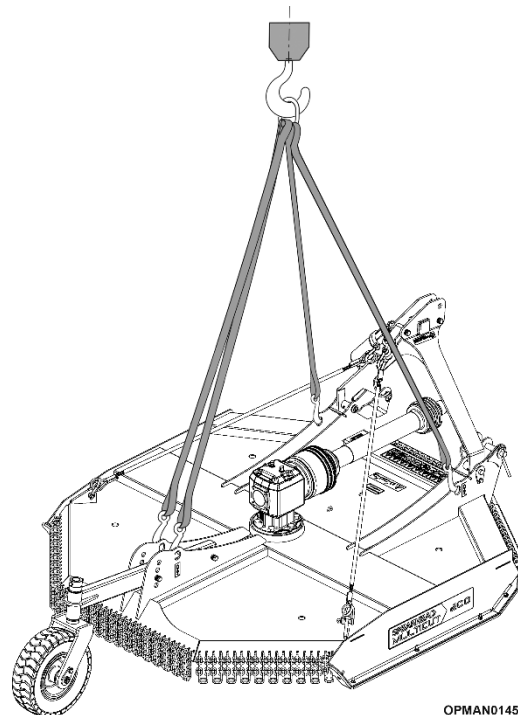

**Figure 3.1 Shipping Position – Multicut 160/200**

Ensure that the machine is guided by personnel when positioning the machine to where it is required to be placed. This is to ensure that the machine and/or equipment/personnel do not get hit by the machine.

Ensure that wherever the machine is going to be positioned afterwards is sturdy and level, so that the machine does not end up becoming unstable and will potentially move or fall over. Consider supporting the machine with additional chocks to ensure it remains stationary.

### 3.2 Post-delivery/First Use Inspection

#### 3.2.1 Tractor Inspection

It is important to read the tractor manufacturer's operators manual to ensure that a complete inspection to the manufacturer's recommendations is carried out on the tractor ensuring it is in correct working condition and has the correct safety measures in place for use. It is important before use to check the suitability of the tractor using the manufacturer's manual to ensure it meets the requirements to fit and operate correctly with the machine.

#### 3.2.2 Machine Adjustment

The machine when received from Spearhead is virtually complete and components are set correctly, requiring minimum time to ready the machine for use. Spearhead machines are tested after manufacture.

It is important to assess the machine to ensure that it is of the correct specification ordered from Spearhead or local Spearhead dealer. Information with regards to the specification of the machine can be found on the machines serial plate. Guidance to the location of the serial plate can be found in Section 1.3.

Before use it is important to inspect the machine following the guidance in this operators manual to ensure it is correctly set-up and is suitable for the attaching tractor using the inspection guidance sheet in Section 5.9.

### 3.3 PTO Shaft

#### 3.3.1 PTO Setup & Adjustment (first use)

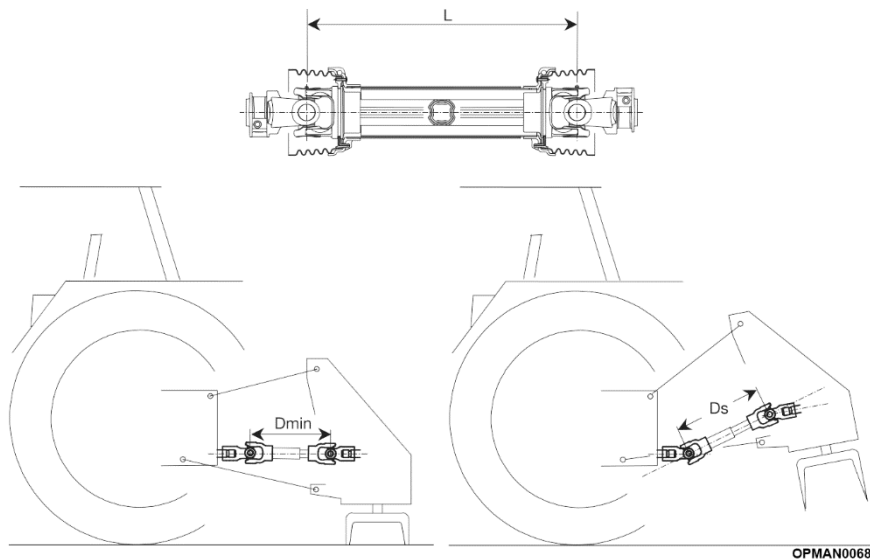

**Figure 3.2 –Input Shaft Overlap**

The PTO of your machine will be delivered as it left the manufacturer, so will require to be shortened to give the correct effective length between the machine and the power take-off of the tractor.

In order to determine the correct length of the finished driveline (L), hook the machine to the tractor, leaving the machine on the ground and proceed to install the two uncoupled/unprotected semi-shafts to their respective tractor/machine PTO's; see Figure 3.2. It is important that when fitting the two semi-shafts, the distance between the joints, "Dmin", is more than the original length "L" of the closed removed input shaft. This is so that the input shaft tubes aren't "bottomed". For guidance on fitting input shafts; see Section 4.4.

When using the machine and moving in between the lowest "working" position and the highest, most raised "transport" position, the distance between the joints will further shorten. This is "Ds". By carrying out a "Bottoming Out Test" as stated in Section 3.3.2, verify any interference of the outer tube with the yoke inner tube and establish how much the outer tube needs to be shortened.

The input shaft should be shortened to ensure:

- At least 25mm (1") clearance at the between the end of the shaft and the universal joint
- At least 1/3 of the shafts length overlap engagement between the two tube halves

Check and ensure that the shaft has been sufficiently maintained and prepared before proceeding to use using the machine following the guidance given in Section 5.2.2.

### 3.3.2 Bottoming Out Test

	<b>Equipment Required</b>
	<ul style="list-style-type: none"> <li>• Coloured tape</li> <li>• Tape measure</li> <li>• Marker pen or plastic scribe</li> </ul>

It is important to test whether the shaft has been sufficiently shortened to protect against “bottoming out” by:

- 3.3.2.1 Disconnecting the input PTO shaft and fully compress the two halves of the shaft together
- 3.3.2.2 Placing a piece of coloured tape on the inner shield 5mm (3/16”) away from the end of the outer shield
- 3.3.2.3 Reattach the PTO shaft between the tractor and machine with the machine placed on the ground.
- 3.3.2.4 Slowly raise the mower **without** the PTO shaft engaged
- 3.3.2.5 If at **any** point the outer shield end becomes any closer than 50mm (2”) away from the placed tape, then shorten the PTO shaft and then test again

To effectively shorten and modify the input shaft; see Section 3.3.3.

**NOTE:** When determining the minimum lengths and during subsequent verifications, it is important to bear in mind that ground subsidence may cause further reduction or increase in the distance between the PTO's.

### 3.3.3 Modifying & Shortening The Input PTO Shaft

Bondioli & Pavesi, the manufacturer of the PTO shafts which comes with all Multicut machines **do not recommend** modifications to its products. This is further supported by Spearhead.

**NOTE:** Bondioli & Pavesi and Spearhead declines all responsibility for damage and/or injury caused by modifying ANY of the power take-off shafts on Multicut machines in any other way than described in this manual. **If you are unsure of the procedure**, or need additional assistance, please **contact your local Spearhead dealer, qualified service centre or Spearhead**.

	<b>Equipment Required</b>
	<ul style="list-style-type: none"> <li>• Tape measure</li> <li>• Marker pen or plastic scribe</li> <li>• Hacksaw or angle grinder (with cutting disc)</li> <li>• Flat hand file or angle grinder (with sanding disc)</li> <li>• NLGI #2 Molybdenum Disulphide grease with paint brush/distributor</li> </ul>

Proceed as follows to shorten the input PTO shaft:

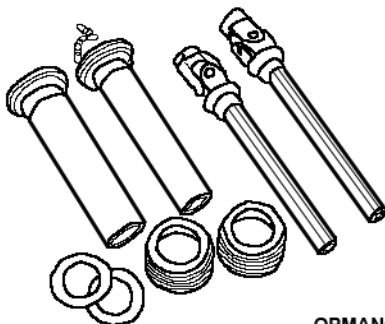

OPMAN00067  
**Figure 3.3**

3.3.3.1 Remove shielding.



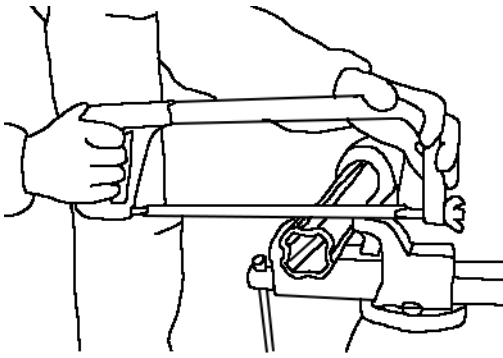

OPMAN00068  
Figure 3.4

- 3.3.3.2 Shorten drive tubes by the required length. In normal conditions, telescopic tubes must always overlap **by at least a ½ of their length**. During manoeuvres, when the driveline is not rotating, the telescopic tubes must have a suitable overlap to maintain the tubes aligned and allow them to slide properly. See Section 3.3.2.

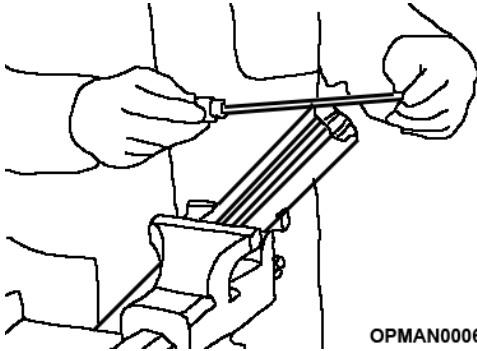

OPMAN00069  
Figure 3.5

- 3.3.3.3 Carefully deburr the ends of the tubes with a file and remove any chippings from the tubes.

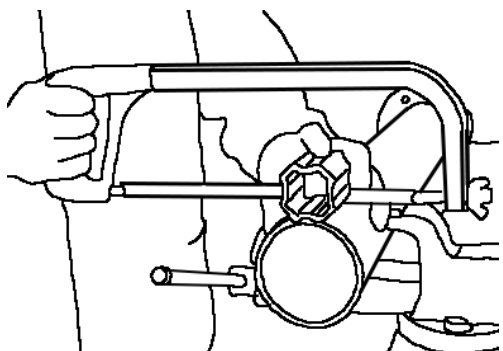

OPMAN00070  
Figure 3.6

- 3.3.3.4 Shorten shield tubes one at a time by cutting the same length that was cut from the drive tubes.

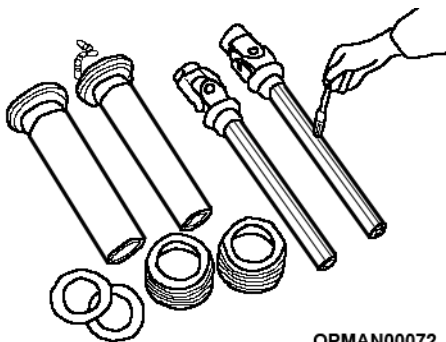

OPMAN00072  
Figure 3.7

- 3.3.3.5 Grease the internal drive tube. Reassemble the shield on the driveshaft.

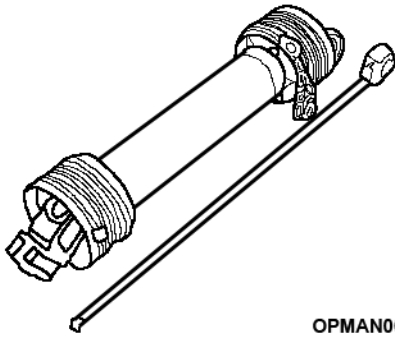

OPMAN00071

**Figure 3.8**

- 3.3.3.6 Check the length of the driveshaft at the minimum position to ensure the shaft will not bottom. See Figure 3.2 for guidance.

If further adjustment is required; repeat the process.

### **3.3.4 Fitting The PTO Shaft**

For guidance on fitting the Power Take Off (PTO) shaft between the machine and tractor; see Section 4.4.

(This page is left blank intentionally)

## 4 Usage Instruction

### 4.1 Operator Requirements



**IMPORTANT:** Read, understand and follow the safety messages stated throughout this section and the rest of this operator's manual. Serious injury or death may occur unless care is taken to follow the warnings.

Safe operation of the Multicut machine is down to the responsibility of the qualified operator. A qualified operator has thoroughly read and understood the machine and attaching tractor operator's manuals and is experienced in the correct and safe operation of both machines and all associated safety guidance. In addition to the safety information contained in this manual, warning and operational decals are fixed around the machine; see Section 2.5.2. The connecting tractor will also have them as well with information given in the tractor operator's manual.

If any part of the operation safe use of the machine is not completely understood, consult a local Spearhead dealer or Spearhead for complete explanation.

If the operator cannot read the manuals for themselves or does not completely understand the operation of the equipment, it is the responsibility of the supervisor to read and explain the manuals, safety practices and operating instructions to the operator.

#### Personal Protection Equipment (PPE)

See Figure 4.1

- Always wear safety glasses
- Hard hat
- Steel toe safety footwear
- Gloves
- Hearing protection
- Close fitting clothing
- Respiration or filter mask (depending on working conditions)



OPMAN00161

Figure 4.1 - PPE Items



**DANGER!** Do not use drugs or alcohol immediately before or while operating the tractor and machine. Drugs and alcohol will affect an operator's alertness and concentration and ability to operate the collective machinery safely.

Before operating the tractor and machine, a machine operator on prescription or over-the-counter medication must consult a medical professional regarding any side effects of the medication that would hinder their ability to operate the equipment safely.

Supervisors must **never** allow anyone to operate the collective machinery when it is known that their alertness or coordination is impaired. Serious injury or death could occur to the operator and/or bystanders if the operator is under the influence of drugs or alcohol.



OPMAN00162

Figure 4.2 – Do Not Use Drugs Or Alcohol

## 4.2 Tractor Requirements

The tractor used to operate the machine must have sufficient capacity to lift, pull and operate the Power Take Off (PTO) at the machines rated speed (540 rpm) while travelling at a working ground speed for the conditions and quantity of material of the work site. Operating the machine with a tractor which does not meet the requirements set by Spearhead may cause the tractor and/or machine damage, potentially risking danger to the operator and bystanders.

The working tractor **MUST** effectively offer the following characteristics to fit the Multicut 160/200 machine.

Tractor Requirement (1)	Machine	
	Multicut 160	Multicut 200
Driver Protection	Approved cab (for country of use) with protective structure or Roll Over Protection Structure (ROPS) and seat belt. See local tractor standards (2)	
Safety Devices	Slow Moving (SMV) emblem, lighting, PTO master shield. See local tractor standards (3)	
Horsepower Requirement	40hp/30kW (4)	50hp/37kW (4)
Drawbar	Category 1/2 mounted with floating clevis top link	
Front End Weights	Required in order to maintain the 20% weight required on the front axle (5)	
Power Take Off (PTO)	540 RPM 1" 3/8 6-spline or 21-spline; see Section 1.5.2.1	

**Table 4.1 - Tractor Requirements and Capabilities**

### Notes:

- (1) Spearhead constantly reviews and improves product designs and reserve the right to change this information. Contact your Spearhead Sales representative if you have any queries.
- (2) The tractor must be fitted with a locally approved cab or Roll Over Protection Structure (ROPS) and have a seat belt to protect the operator from falling from the tractor or during a rolling over incident. Only operate the tractor when seated in the operator's seat with the seat belt securely fastened.
- (3) All guarding must be maintained to perfect working condition. Always replace shields and guards that were removed for access to service or repair the tractor or machine. Never operate machine/tractor without all safety devices in position.
- (4) Variations in power requirement can depend on the vegetation to be cut, terrain condition, operator experience and the physical condition of the machine and/or tractor. Running a machine on an overly large tractor may cause damage through overpowering the machine in heavy working conditions.
- (5) Front end weight is critical to maintain steering control and prevent the tractor from rearing up. Front weight and weight carriers can be purchased through an authorized tractor dealership.
- (6) Refer to the tractor owner's manual for instructions on how to change PTO speeds on models with more than one speed.

## 4.3 Hitching & Unhitching The Machine



**DANGER!** Always switch off the tractor completely, place the transmission in park, and set the parking brake before attempting to connect or disconnect the machine from the tractor

### Hitching

This section of instructions are written on the assumption that the machine is being connected to the tractor when its in a secure and stable state on a flat, hard surface.

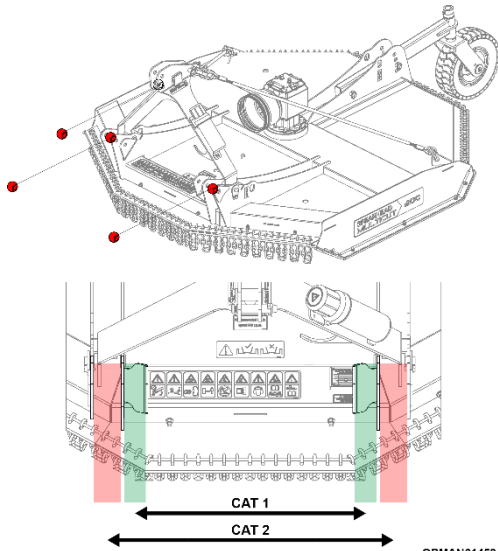

OPMAN01453

**Figure 4.3**

- 4.3.1.1 Remove the top and lower link pins from the machine and fit the linkage balls (not supplied with the machine).

Multicut 160/200 machines have the ability to be fitted to Category 1 and Category 2 tractors as there are two different fitting points for the lower linkage balls.

Select the narrower position to fit the machine at Category 1 and the wider position to the machine at Category 2; see Figure 4.3.

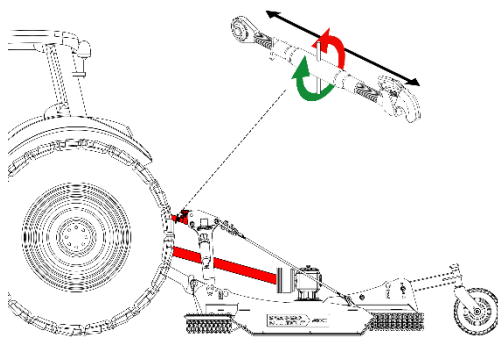

**Figure 4.4**

- 4.3.1.2 Carefully bring the tractor towards the machine so the lower link arms line up with lower link balls at the front of the machine. Switch off the tractor and apply the handbrake.

- 4.3.1.3 Fit the top link of the tractor to the machine, adjusting its length to the machine until it reaches and the ball engages with the top link.

- 4.3.1.4 Fit the PTO shaft between the tractor and machine.

- 4.3.1.5 Start the tractor and gradually raise the lower links to securely engage the balls of the lower links. The latches of the tractor will engage. Continue to raise the machine until the rear wheel is off the ground.

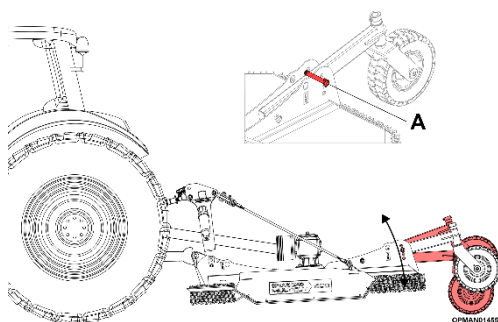

**Figure 4.5**

- 4.3.1.6 Stop the tractor and proceed to adjust the rear wheel to the required cutting height by removing the rearward pins in the wheel arm (A). Replace once set in the respective hole.

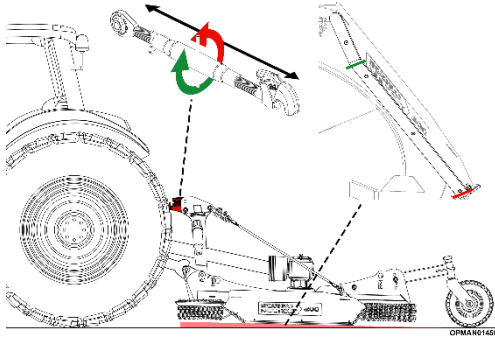

**Figure 4.6**

- 4.3.1.7 Start the tractor and lower the machine until the rear wheel is touching the floor.
- 4.3.1.8 Stop the tractor and proceed to adjust the top link between the tractor and machine in order to set the deck at the correct operating angle. To do this its best practice to measure the front and rear of the skids; as shown in Figure 4.6. Furthering this, ensure that there is slack in the headstock wire ropes in order to allow the headstock to float when in work on undulating terrain.

For full guidance on setting up the machine; see Section 4.4.

## **Unhitching**



**DANGER!** Always switch off the tractor completely, place the transmission in park, and set the parking brake before attempting to connect or disconnect the machine from the tractor

Unhitching the machine is a reverse operation of the hitching process stated in the previous section. Ensure that the input shaft has been removed following the guidance given in Section 4.4.1.

**IMPORTANT:** Unhitching and planning to store the machine should be carried out on a level and firm ground to prevent the machine from rolling away.

- 4.3.1.9 With the machine raised sufficiently off the ground, stop the tractor and proceed to adjust the rear wheel on the machine by removing the rearward pin on the wheel arm to raise the wheel to a high enough position in order to allow the machine when lowered back to the ground to sit level and most secure on its skids. Replace the pins once set in the respective hole.
- 4.3.1.10 Start the tractor and gradually lower the machine to the ground.
- 4.3.1.11 Stop the tractor and lengthen the top link in order to lie the headstock towards the driveline guard of the machine. Disconnect the top link from the headstock of the machine.
- 4.3.1.12 Proceed to remove the PTO shaft using the guidance given in Section 4.4.1.
- 4.3.1.13 Securely chock the machine behind each of the skids to ensure that the machine doesn't move when its in storage.
- 4.3.1.14 Release the links on the latches of the lower links of the tractor.
- 4.3.1.15 Return to the tractor, start the engine and gently drive away.
- 4.3.1.16 Ensure that the input shaft is kept off the floor and remains with the machine to ensure it doesn't get damaged. If the machine is not destined to be used for an extended period, fully disconnect the input shaft and consider bringing it indoors to maintain its condition.

For extended guidance on how to safely store the machine; see Section 5.10.

## 4.4 PTO Shaft



**CAUTION!** Many of the equipment components listed in this section used to carry out processes are heavy (25kg/60lbs+), and special lifting procedures are recommended to reduce potential user lifting injuries. Use mechanical lifting assistances, two people and other proper lifting techniques when connecting the input PTO shaft between the machine and tractor.

### 4.4.1 Fitting & Removal Of The Input PTO Shaft

#### Fitting

Make sure before proceeding to try to fit the input PTO shaft between the tractor and machine that the specification of the shaft is the correct speed, size and has the correct quantity of splines for the machine and the tractor can offer the machines required PTO speed.

Furthermore, ensure that it's been adjusted to the correct length for use between the machine and the given tractor as stated in Section 3.3.1.



**DANGER!** Do not use PTO adaptors to attach a non-matching implement driveline to a tractor PTO. Use of an adaptor can double the operating speed of the implement resulting in excessive vibration, thrown objects, blade/chain/driveline failures due to changes in the machines design intended use. PTO adaptors also increase the exposed working length increasing the probability of entanglement with external objects. If the shaft is incorrect for the tractor; contact your local Spearhead dealer for assistance.



**WARNING!** When attaching the machine input shaft to the tractor power take-off, it is important that the connecting yoke spring activated button operates freely allowing the PTO to slide freely and the locking balls to seat securely in the groove on the tractors output PTO shaft.

Push and pull the input shaft back and forth several times to ensure it is securely attached and the button returns to its outwards position. An input shaft not attached correctly to the tractor PTO shaft could come loose and result in personal injury and damage to the machine.

Both the input shaft yoke and tractor PTO shaft must be dirt free and a light smearing of grease should be applied prior to attachment.



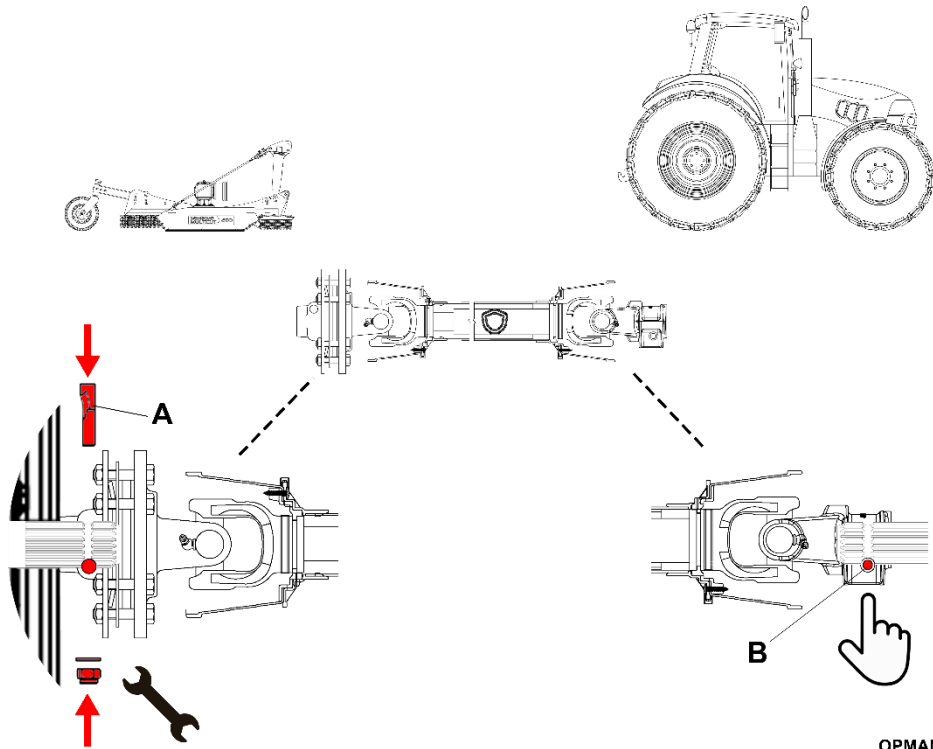

OPMAN01458

**Figure 4.7 – Multicut Input Shaft Fitting & Removal**

### **Fitting - Machine End**



#### **Equipment Required**

- Torque wrench (see required settings in Torque Settings section)
- 22mm hex socket
- NLGI #2 Molybdenum Disulphide grease with paint brush/distributor

Proceed as follows:

- 4.4.1.1 Proceed to remove the taper pin, flat washer and nut from the machine end of the input PTO shaft. See Figure 4.7 (A).
- 4.4.1.2 Install the input PTO shaft onto the rotor gearbox lining up the slot in the rotor gearbox shaft with where the input shaft taper pin will be placed; see Figure 4.7 (A). Replace the removed taper pin, flat washer and nut and tighten to a torque of 230Nm (170 ft/lbs).

It is best practice, when fitting the input shaft to wipe a small quantity of grease (NLGI #2 Molybdenum Disulphide) onto the splines to aid assembly and later removal.

## **Fitting - Tractor End**

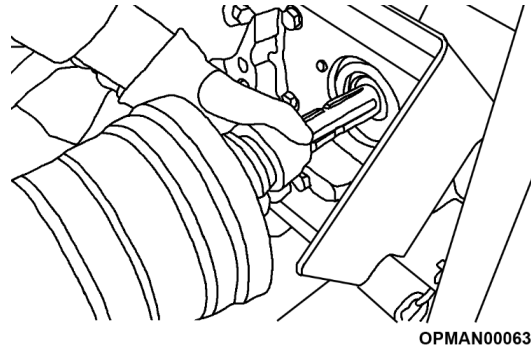

**Figure 4.8 – Fit Input Shaft To Tractor**

Proceed as follows:

- 4.4.1.3 Press the input shaft spring button and align the grooves and splines with those of the PTO output shaft of the tractor; see Figure 4.7 (B).
- 4.4.1.4 Push the driveline yoke onto the tractor output PTO shaft, release the spring button and position the yoke of the input shaft until the spring button balls are seated onto the tractors output PTO shaft; see Figure 4.7 (B).
- 4.4.1.5 To ensure that the input PTO shaft is secure, push and pull the shaft back and forth several times.

It is best practice, when fitting the input shaft to wipe a small quantity of grease (NLGI #2 Molybdenum Disulphide) onto the splines to aid assembly and later removal.

## **Removal**



### **Equipment Required**

- 22mm (M14) socket or spanner
- NLGI #2 Molybdenum Disulphide grease with paint brush/distributor

Removing the input shaft is a reverse procedure to what is stated in the fitting section; by removing the shaft from the tractor end first. Ensure that the PTO is disengaged, tractor engine is stopped and the handbrake is applied before proceeding to remove the shaft.

It is best practice, when removing the input shaft, to wipe a small quantity of grease (NLGI #2 Molybdenum Disulphide) onto the splines of the exposed shaft end to prevent corrosion.

If the machine is not going to be used for an extended length of time the input shaft should be removed completely and stored indoors to maintain its condition.

Proceed as follows:

- 4.4.1.6 Press the input shaft spring button and pull back the shaft off the output splined shaft of the tractor; see Figure 4.7 (B).
- 4.4.1.7 To then completely remove the shaft, remove the taper pin, flat washer and nut from the machine end; see Figure 4.7 (A).
- 4.4.1.8 Refit the removed taper pin, flat washer and nut for safe keeping.
- 4.4.1.9 It is best practice, when removing the input shaft to wipe a small quantity of grease (NLGI #2 Molybdenum Disulphide) onto the splines at each end to aid later refitting to the tractor.

## 4.4.2 PTO Shaft Specifications

Multicut machines are sold to operate at 540 rpm.



**DANGER!** Do not use PTO adaptors to attach a non-matching implement driveline to a tractor PTO. Use of an adaptor can double the operating speed of the implement resulting in excessive vibration, thrown objects, blade/chain/driveline failures due to changes in the machines design intended use. PTO adaptors also increase the exposed working length increasing the probability of entanglement with external objects. If the shaft is incorrect for the tractor; contact your local Spearhead dealer for assistance.

It is important to only operate at these speeds as a **maximum** and that the input PTO shaft is of the correct specification for the machine and tractor. See Table 4.2 for input shaft speed options and the spline quantity options.

Machine	PTO Speed	Number Of Splines
Multicut 160/200	540 rpm	6
	540 rpm	21

**Table 4.2 – Input Shaft/PTO Speed Options**

Multicut 160/200 machines feature a two plate clutch on the input shaft.

**NOTE:** Some tractors offer the ability to change the PTO operating speed between 540/1000 RPM. Ensure that the correct PTO operating speed is selected for the machine. Refer to the tractor owner's manual for instructions on how to change PTO operating speed before proceeding to start the machine.

## 4.5 Setting Up The Machine

It is important to set the machine up properly front to rear to ensure for safe operation and efficient working ability. A properly set up machine will give a more uniform cut, follow ground contours better and distribute its cut material more evenly out of the rear of the machine. It will also require reduced tractor work and effort from the operator.

Setting up the machine should always be carried out with the machine on the floor resting on the rear wheel.

### 4.5.1 Front To Rear



#### Equipment Required

- Tape measure



**WARNING!** It is mandatory to switch the combustion engine off and disengage PTO and ensure that the machine is stopped and the parking brake is engaged before leaving the driver's seat and proceeding to adjust the levelling of the machine.

Once coupled to the tractor, check the machine is cutting level from the front to the rear.

To level the machine front to rear:

- 4.5.1.1 Place the machine on a level concrete surface, with the machine lowered onto the ground. Depending on the position of the rear wheel setup, this will be either on the rear tyre or directly on the machine skids.
- 4.5.1.2 Measure the machine at the front and rear of the skids; see Figure 4.9 to determine the height of the front and rear of the machine.
- 4.5.1.3 Adjust the top link between the tractor and machine headstock in order to raise or lower the front of the machine if required. Lengthening the top link will raise the front of the machine and shortening the top link will lower it.

Aim to adjust the machine so that the front of the skid is pitched around 15mm (1") higher than the rear. This has been found to give the most efficient operating ability and best cut from the machine.

4.5.1.4 Secure the top link in position so it will not change positions during work or transport.

**IMPORTANT:** Ensure that the machine tyre pressures is set correctly. See Section 5.6.1 for correct tyre pressures.

**NOTE:** Keep in mind that the tyre may sink in soft conditions when the machine is in use altering the actual cut height; see Figure 4.10. As a safe precaution, set the cutting height slightly higher on set-up to cater for this sinking. Assess the working area after and then adjust again if required.

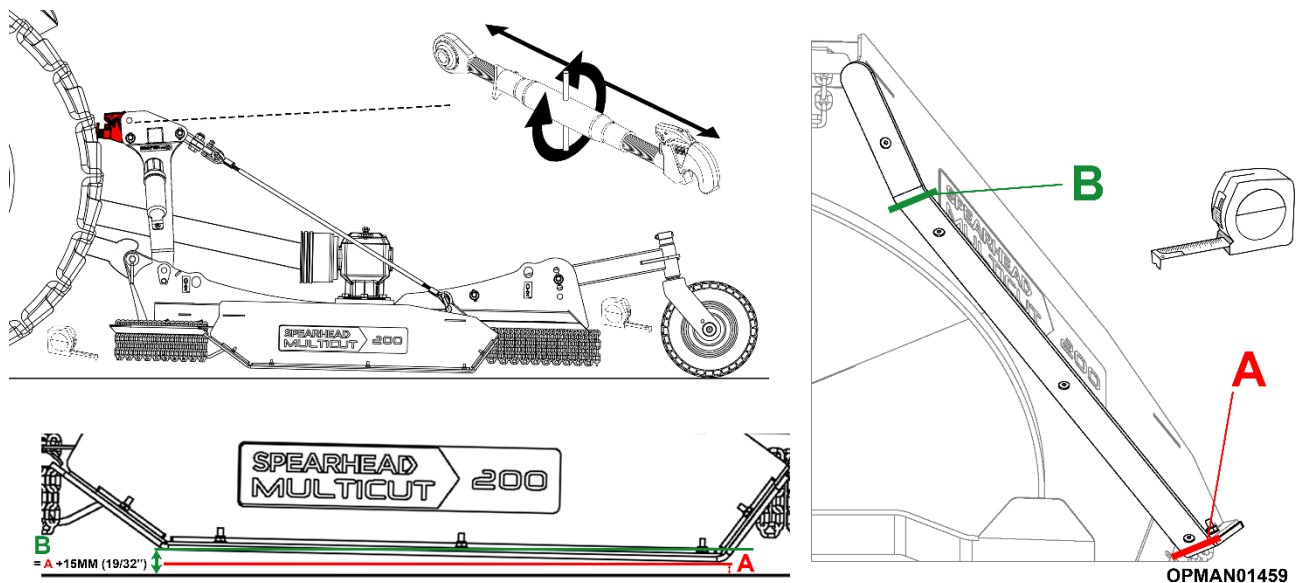

Figure 4.9 – Multicut 160/200 Front To Rear Machine Levelling



Figure 4.10 – Tyre Sinking

## 4.6 Setting Cutting Height

### 4.6.1 Multicut 160/200

With reference to Figure 4.12 - 4.14, to alter the minimum height of cut:

4.6.1.1 Start the tractor and gradually raise the machine until the rear wheel is off the ground.

4.6.1.2 Stop the tractor and proceed to adjust the rear wheel arm to the desired position.

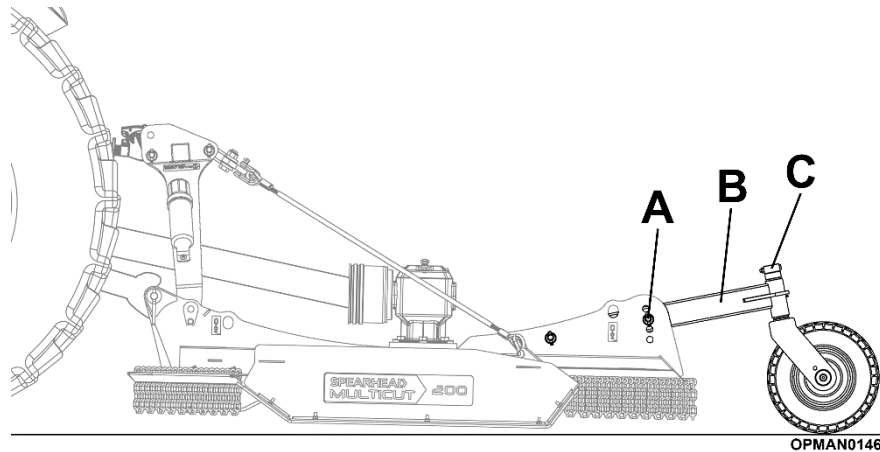

**Figure 4.11 – Multicut 160/200 Height Adjustment Dependent Variables**

Multicut 160/200 machines can be set-up in a variety of different configurations through adjusting and altering:

1. Wheel arm pin position (ref Figure 4.11 (A) and Figure 4.12)
2. Wheel arm orientation (ref Figure 4.11(B) and Figure 4.13)
3. Wheel yoke spacer positions (ref Figure 4.11(C) and Figure 4.14)

By changing the combination of these various items and setting them up in different ways will give different cutting heights from the machine.

**For guidance cutting height settings; see Table 4.3.**

Ensure that before proceeding to use the machine that all height pins are replaced and secured in position with the supplied lynch pin and the wheel yoke spacer fasteners are tight.

4.6.1.3 Return to the tractor and gently lower the machine.

Table 4.3 shows a **reference** guide as to the minimum height of cut that will result.

This table of data is just for reference to create a ballpark figure for the customer to start from and assumes:

- Tyre pressure is correct
- Levelling is carried out on perfectly level and firm ground
- A brand new machine with no worn components
- The machine is perfectly set levelled front to rear as shown in Section 4.5.1
- The machine is perfectly manufactured and there is no tolerance variation in components

Due to this Spearhead shows the data below as a reference holding no responsibility for the machine not achieving the **exact** quantities given in the table below. It is important for the operator to try out the machine at the work site with the expectation that they will need to adjust the machine after to get exactly what they require to fit the working conditions.

With reference to Table 4.3, note that some cutting height measurements are achieved by operating the machine directly on the wear skids rather than on the wheel arm tyre.

To gain the correct cutting height required select the right settings of the three following variables:

**1. Wheel Arm Pin Hole Positioning**

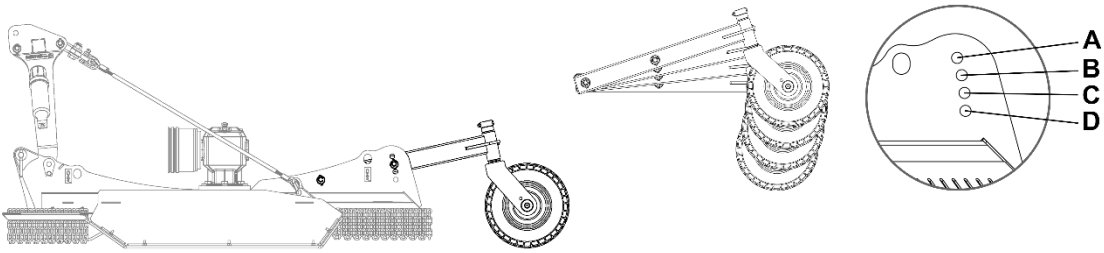

OPMAN01462

**Figure 4.12**

**2. Wheel Arm Orientation**

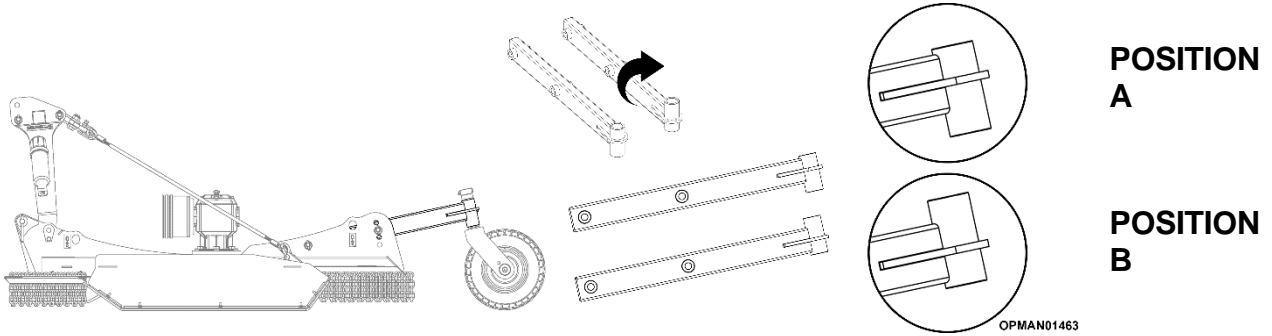

OPMAN01463

**Figure 4.13**

**3. Wheel Yoke Spacer Positions**

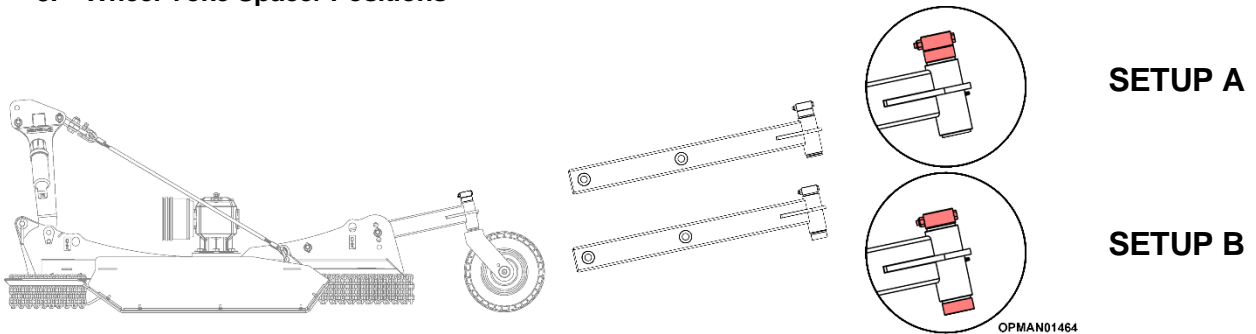

OPMAN01464

**Figure 4.14**

SETTING	1 – Figure 4.27 Wheel Arm Orientation				2 – Figure 4.28 Wheel Arm Pin Hole Positioning		3 – Figure 4.29 Wheel Yoke Spacer Positions		Cutting Height mm (inches)
	1	2	3	4	A	B	A	B	
	1	X				X		X	
2	X				X			X	32mm (1 ¼")*
3	X					X	X		32mm (1 ¼")*
4	X					X		X	32mm (1 ¼")*
5		X			X		X		42mm (1 5/8")
6		X			X			X	66mm (2 5/8")
7		X				X	X		32mm (1 ¼")*
8		X				X		X	37mm (1 7/16")
9			X		X		X		155mm (6 1/8")
10			X		X			X	174mm (6 7/8")
11			X			X	X		125mm (4 15/16")
12			X			X		X	150mm (5 15/16")
13				X	X		X		265mm (10 7/16")
14				X	X			X	290mm (11 7/16")
15				X		X	X		235mm (9 ¼")
16				X		X		X	262mm (10 5/16")

**Table 4.3 – Multicut 160/200 Cutting Height Adjustment**

\*- Machine running on wear skids, rather than on tyre

## 4.7 Work Site Assessment

### 4.7.1 Foreign Debris Hazards

The destined work site to use the machine should be thoroughly checked and familiarised following the guidance given in Section 2.3.4 to assess the working area for hazards; removable and fixed.

Items should be assessed, removed or clearly marked (e.g. if too heavy to move) before mowing:

- Items and ground characteristics which could cause a reduction in the tractors stability and traction and operator safety and ease of control in operation
- Insufficient lighting
- Foreign objects which could be picked up and then flung by the machine damaging and causing risk to bystanders, operator, tractor or the nearby environment. Items seen on the surface and buried deeply in the material. For example rocks, tree stumps and manhole covers
- Foreign objects which could be picked up and then damage the machine; for example wire.
- Low level objects which could come into collision with the tractor and/or machine
- Items which could create a fire risk

In overgrown areas which could potentially hide debris that could be struck by the blades/chains, the area should be: inspected and large debris removed, mowed at an intermediate height and then re-inspected closely with any remaining debris being removed. Then mow at the desired final height. This will also bring benefits to operations with reduced power requirements to mow, reduce wear and tear on the machine drivetrain, spread cut material better, reduce windrowing, and give a better overall finish.

Always wear your seat belt securely fastened and only operate the tractor and mower with the Roll-over Protection Structure (ROPS) in the raised position. If the tractor or mower hits a tree stump, rock, or bump, a sudden movement could throw you off the seat and under the tractor and/or mower. The seat belt is your best protection from falling off the tractor and the ROPS provides protection from being crushed during a tractor roll-over.



**Figure 4.15 – Inspect The Work Site**

It is important to inspect the machine to ensure all mandatory fixed and removable guarding is in position and in correct working order before proceeding to use the machine. For guidance on the various guarding found on the Multicut machine; see Section 2.6.



**WARNING!** Extreme care should be taken when operating near loose objects such as gravel, rocks, wire, and other debris. Inspect the area before mowing. Foreign objects should be removed from the site to prevent machine damage and/or bodily injury or even death. Any objects that cannot be removed must be clearly marked and carefully avoided by the operator. Stop mowing immediately if blades/chains strike a foreign object.

**IMPORTANT:** Repair all damage and make certain rotor or blade/chain carrier is balanced before resuming mowing.



**WARNING!** Many varied objects, such as wire, cable, rope, or chains, can become entangled in the cutting area of the mower deck. These items can swing outside the confines of the safe cutting area of the machine at greater velocities than the blades/chains. Such a situation is extremely hazardous and could result in serious injury or even death. Inspect the cutting area for such objects before mowing. Remove any like object from the site. Never allow the cutting blades/chains to contact such items.



## 4.7.2 Stopping The Machine In An Emergency



**DANGER!** If the machine hits an object, becomes jammed, suddenly develops vibration or any other potentially harmful change happens to the machine.

**Stop the machine immediately!**

If you hit a solid object or foreign debris:

- 4.7.2.1 Return the tractor to idle engine speed immediately.
- 4.7.2.2 Disengage the PTO.
- 4.7.2.3 Wait for all machine rotating parts to stop, then raise the mower and move the tractor and machine off the object.
- 4.7.2.4 With **extreme** caution, if a blocked foreign component has caused the machine to suddenly operate incorrectly or altogether ensure that all the correct levels of Personal Protection Equipment (PPE) is worn for safety purposes. **Consider gaining extra personnel** for assistance.
- 4.7.2.5 If the cause of sudden incorrect running of the machine is due to the machine colliding or hitting a foreign object, inspect the area and remove, or mark the location of the debris so it's not hit again.
- 4.7.2.6 Inspect the condition of the machine and make any needed repairs **before** proceeding to use the machine again. Make sure the blades/chains are not damaged and the carrier is balanced before resuming operation.

## 4.7.3 Bystanders



**DANGER!** Machines are capable under adverse conditions of throwing objects for great distances 90m (300 ft) or more and causing serious injury or death. Follow safety messages carefully.

It is of upmost importance that the tractor and machine is stopped immediately if a bystander comes within 90m (300 ft) while operating. The engine should be idled and the PTO disengaged. Do not restart work until the bystander is well past the 90m (300 ft) and then reassessed that there aren't any other new bystanders inside the danger zone.

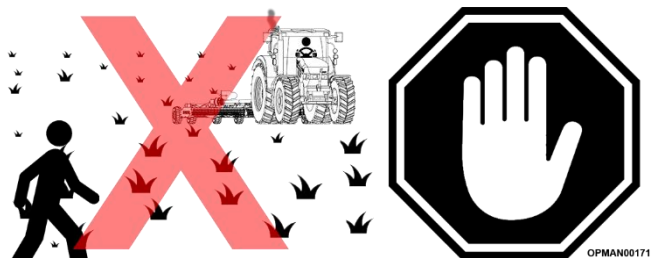

**Figure 4.16 –Bystanders Out Of Working Area**

It is of upmost importance to inspect the destined worksite before commencing work following the guidance given in Section 2.3.4 and Section 4.7.1.

## 4.7.4 Weather

**Mow only in conditions where you have clear visibility** in daylight or with adequate artificial lighting. Never mow in darkness or foggy conditions where you cannot clearly see **at least 90m (300 feet)** in front and to the sides of the tractor and mower. Make sure that you can clearly see and identify passers-by, steep slopes, ditches, drop-offs, overhead obstructions, power lines, debris and foreign objects.

If you are unable to clearly see these type of items do not begin mowing.

## 4.7.5 Fire

Follow the following guidelines to reduce the risk of equipment and grass fires while operating, servicing, and repairing the machine and tractor:

- Ensure the **tractor is equipped with a fire extinguisher** in an easy to access location
- **Do not** operate the machine on a tractor with an underframe exhaust
- **Do not** smoke or have an open flame near the machine and tractor
- **Do not** drive into burning debris or freshly burnt areas
- Never allow clippings or debris to collect near drivelines and gearboxes
- Periodically shut down the tractor and machine and clean clippings and collected debris from the machine deck



Figure 4.17 – Beware Of Fire Hazards

## 4.8 Safe Driving Practices

In order to safely operate the machine in work with the tractor requires the operator to have a thorough knowledge and experience of the tractor they're using and safety precautions they should take whilst driving with the attached machine.

With regards to the tractor and the surrounding environment it is important that the operator can:

4.8.1.1 Ensure the tractor has been properly serviced and maintained. Do not operate the tractor with weak/faulty brakes or worn tyres.

4.8.1.2 Ensure the tractor has the capacity to handle the weight of the machine; see Section 1.5.1

Failure to have at least 20% sufficient load over the front axle or to drive at inappropriate speeds on undulating terrain may result in a loss of directional control.

4.8.1.3 Ensure the tractor operating controls are set for safe transport. Consult the tractor manufacturers operators manual.



**WARNING!** Transport only at speeds where the machine and tractor can be maintained in control. Drive **conservatively**. Serious accidents and injuries can result from operating this equipment at high speeds.

- 4.8.1.4 Before using the tractor and machine ensure that the machine is only operated at safe speeds; on and off road (including work).



**DANGER!** Steering should be taken at slow speeds to maintain machine stability. Violently changing direction will greatly reduce machine stability resulting in loss of steering control, potentially turning over the machine and tractor causing serious injury, or even death

- 4.8.1.5 The operator should start at slow speeds and familiarise themselves of the operating and handling characteristics of the tractor in combination with the fitted machine off road before proceeding to drive the machine onto the public highway. Gentle steering and braking should be adhered to maintain control and overall stability
- 4.8.1.6 Tractor independent brakes should be locked together and the differential lock should be disengaged.
- 4.8.1.7 Before transporting the tractor and machine, determine the legal maximum transport speeds for the equipment conforming to local jurisdictions and comfortable transport speeds for the operator. Only increase speeds safely when conditions allow or the operator is comfortable to do so.



**Figure 4.18 – Follow Safe Driving Practices**

Transport the machine only at safe speeds which allow you to properly control the machine and at a **maximum** speed of 20 mph (32 kph). Drive for the conditions and reduce speed if required. Increasing speeds, operating down a hill or on wet or rain slick roads; increases stopping distances.

- 4.8.1.8 Make certain that the local jurisdiction legal safety requirement items are fitted. For example a “Slow Moving Vehicle” (SMV) sign is installed and tractor flashing warning lights. Check the local jurisdiction to determine whether the flashing warning beacons are required to be switched on when the machine is working.

Make sure all these safety awareness items are clearly visible and legible and follow all local traffic regulations. If the item is in anyway not working correctly or is faded; replace.



**DANGER!** The machine may be wider than the tractor. Be careful when operating or transporting the machine to prevent the machine from running into or striking sign posts, barriers, walls, cars or any other solid objects. Such an impact could cause the tractor and/or machine to violently change direction or balance resulting in loss of steering control, serious injury, or even death.

- 4.8.1.9 Be aware of other road users and bystanders and make the machine aware to other users. Check your side view mirrors frequently and remember vehicles will approach quickly because of the tractor's slower speed. Gain eye contact with other people to gauge they've seen the tractors presence.
- 4.8.1.10 When operating on public roads, have consideration for other road users. Pull to the side of the road occasionally to allow all following traffic to pass. Do not exceed the legal speed limit set in your local jurisdiction for agricultural tractors. Always stay alert when transporting the tractor and machine on public roads. Use caution and reduce speed if other vehicles or pedestrians are in the area.
- 4.8.1.11 Make sure all tractor lighting is functioning correctly. Older tractors may not feature as many/bright lights as modern tractors. Consider upgrading the lights by consulting your authorized tractor dealer to ensure that the tractor and machine presence is seen.
- 4.8.1.12 Be extremely cautious when the piece of equipment that is being carried is wider than the tractor tire width and/or extends beyond the lane of the road.

- 4.8.1.13 It is of utmost importance that safety decals are kept clean and replaced if they are no longer legible, damaged or lost completely. Safety decals can be purchased readily from a local Spearhead dealer.

## 4.9 Using The Machine

### 4.9.1 Engaging The Power Take-off (PTO)

Only operate the machine from the tractor operator's seat with the seatbelt securely fastened. The tractor must be equipped with a ROPS cab.



**WARNING!** Do not let the blades/chains turn when the machine is raised for any reason; including clearance or for turning. Raising the machine exposes the cutting blades/chains which creates a potentially serious hazard and could cause serious injury or even death from objects thrown from the blades/chains.



**WARNING!** Do not put hands or feet under mower deck. Blade contact can result in serious injury or even death. Stay away until all motion has stopped and the deck is securely blocked up.

**Before** engaging the PTO, make certain that the area is clear of bystanders and passersby. The machine must be completely lowered to its desired cutting position. **Never** engage the PTO with the implement in the raised position.

- 4.9.1.1 Set the tractor engine speed at approximately 1,000 RPM before engaging the PTO.
- 4.9.1.2 Shift/press the PTO control to the on position.
- 4.9.1.3 Slowly increase the engine speed until the PTO is operating at the rated speed.

**IMPORTANT:** If you hear unusual noises or see or feel abnormal vibrations, disengage the PTO immediately. Inspect the implement to determine the cause of the noise or vibration and repair the abnormality before proceeding to use the machine.

### 4.9.2 Disengaging the Power Take-off (PTO)

To shut down the machine:

- 4.9.2.1 First bring the tractor to a complete stop.
- 4.9.2.2 Decrease engine RPM to idle then disengage the PTO.  
The machine will come to a complete stop within a suitable amount of time.

**IMPORTANT:** Do not engage or disengage the machine at a high RPM unless there is an emergency situation.

Park the tractor on a level surface, place the transmission in park or neutral and apply the parking brake, lower the machine to the ground, shut down the engine, remove the key, and wait for all motion to come to a complete stop before exiting the tractor.

### 4.9.3 Forward & Power Take-off Speed

Once the power take-off has been engaged following the guidance given in Section 4.9.1, start off driving at a slow speed and gradually increase while maintaining complete control of the tractor.

Moving slowly at first will prevent the tractor from rearing up and loss of steering control. The tractor should never be operated at speeds that cannot be safely handled or which will prevent the operator from stopping quickly during an emergency. If the power steering or engine ceases operating, stop the tractor immediately as the tractor will be difficult to control.

Spearhead mounted machines are designed to cut vegetation up to 100mm (4") diameter. Sharp blades will produce a cleaner cut and require less power. Travel at a speed that allows the mower sufficient time to cut through the vegetation and maintain the PTO operating speed to prevent overloading the mower and tractor. Choose a driving pattern that gives maximum pass length and least turning.

Speed for mowing will dependent upon the height, type, and density of the material to be cut. Recommended speed for efficient mower performance is between 2 and 5 mph (3-8 kmh). Operate the machine at its full rated PTO speed (540rpm), to maintain blade/chain speed for a clean cut. See the front of the machine for a guidance decal on the rated required operating speed.



**Figure 4.19 – Tractor Driving Guidance**

Refer to the tractor operator's manual or the tractor instrument panel for the engine speed and gear to provide the required PTO and desired ground speed. Make sure that the machine is operating at its full rated speed before entering the vegetation to be cut. If it becomes necessary to temporarily regulate engine speed, increase or decrease the throttle gradually.



**WARNING!** Do not exceed the rated PTO speed for the machine. Excessive PTO speed can cause driveline or blade/chain failures resulting in serious injury or death. See the front of the machine for a guidance decal on the rated required operating speed.

**Forward speed is achieved by transmission gear selection and not by the engine operating speed.** The operator may be required to experiment with several gear range combinations to determine the best gear and range which provides the most ideal performance from the mower and most efficient tractor operation. As the severity of cutting conditions increase, the ground speed should be decreased by selecting a lower gear to maintain the proper operating PTO speed.

Under certain conditions, tractor tires may flatten some grasses down preventing them from being cut at the same height as the rest of the width of the cutting area. When this occurs, reduce the tractor ground speed while maintaining the operating speed of the PTO. A slower ground speed will permit grasses to partially rebound and be cut. Taking a partial cut may also help produce a cleaner cut.



**WARNING!** Never use any Multicut machine in reverse direction. Seek alternate methods of cutting if a desired area cannot be accessed with the machine and tractor.



**WARNING!** Do not mow with two machines in the same area except with cabbed tractors with the windows closed.

#### 4.9.4 Cornering

When operating the machine, if an extreme change of direction is required, for example a 90° turn; disengage the PTO, lift the machine, make the turn and proceed to restart the machine and continue with mowing.

Perform turns with the tractor and mower at slow speeds to determine how the tractor handles with the attached mower. Determine the safe speed to maintain proper control of the tractor when making turns. When turning with a mounted implement, the overall working length of the unit is increased. Allow additional clearance for the mower when turning.

To avoid overturns, drive the tractor with care and at safe speeds, especially when operating over rough ground, crossing ditches or slopes, and turning corners.

Use extreme caution when operating on steep slopes. Keep the tractor in a low gear when going downhill. **Do not** coast or free wheel downhill.

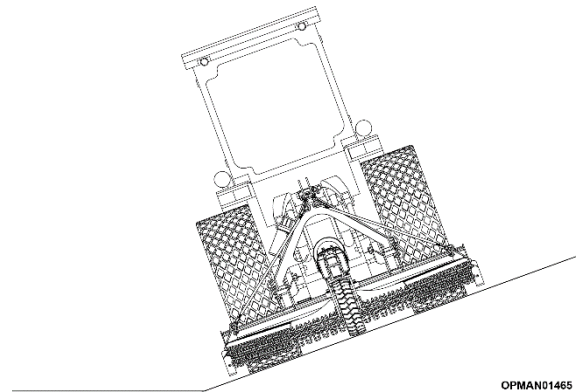

Figure 4.20 – Tractor Stability

It important to ensure that the tractor lower link chains are tight when the machine is fitted. This will limit machine sway from left to right and make it more stable and safe whilst at work or being transported.

#### 4.9.5 Crossing Ditches & Steep Inclines

When confronted with an incline or ditch, **do not approach from an angle which is perpendicular or straight on**. When crossing such terrain, the implement should be fully lowered for a lower centre of gravity and added stability.

Inclines and ditches **should be approached along a line which is at an angle** as shown in Figure 4.21. This type of path will reduce wear on the driveline of the tractor and/or tractor. If the gradient is so steep that such an approach increases the possibility of a tractor roll-over, select an alternate crossing path.

When operating the tractor and machine across slopes and inclines, through ditches, and other uneven terrain conditions, it is important to maintain sufficient deck to ground clearance. Blade contact with the ground may cause soil, rocks and other debris to be thrown out from under the mower resulting in possible injury and/or property damage. Ground contact also produces a severe shock load on the mower drive and to the mower blades/chains resulting in possible damage and premature wear.

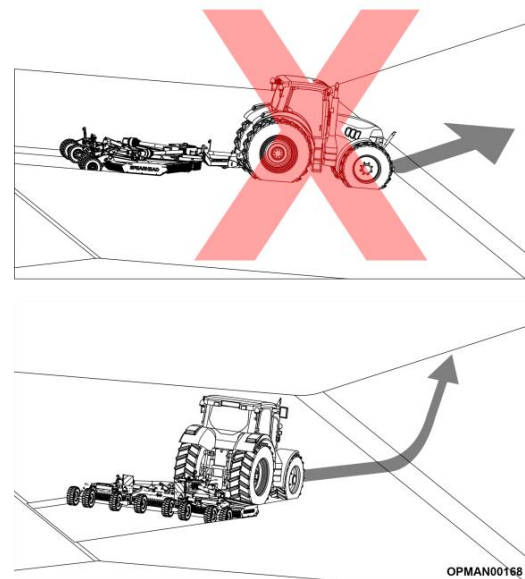

Figure 4.21 – Approach Ditches At An Angle

## 4.9.6 Un-level Ground

When mowing across uneven areas such as road shoulders, ditch edges, and other uneven terrain, position mower so that one support wheel is near the highest point to prevent blades/chains from cutting into gravel or dirt; see Figure 4.22. Contact with the ground will cause accelerated wear on the machine blades/chains and/or blade/chain carrier and cause severe shock loads on the machine driveline resulting in premature damage to these components. Blades/chains contacting the ground may cause objects to be thrown out from under the mower deck. Always avoid operating the mower at a height or position which may cause the blades/chains to contact the ground. Cutting into the berm or edge of the ditch will cause abnormal and accelerated blade/chain wear and possible blade/chain component failure.

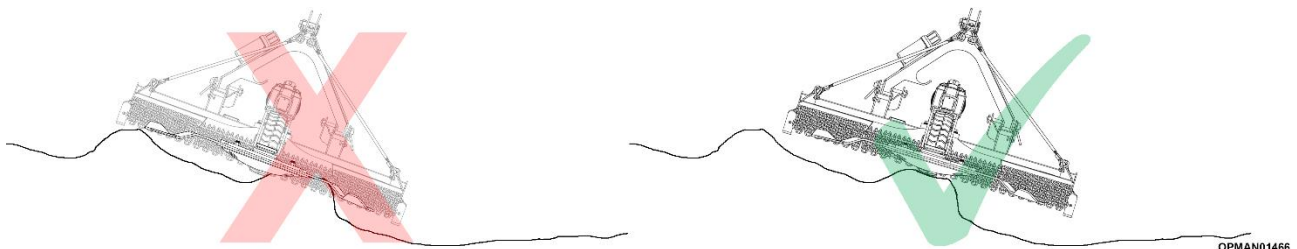

Figure 4.22 – Uneven Ground, Ride On The Tyre Not The Blade/Chain Carrier

## 4.10 Road Transporting The Machine

**IMPORTANT:** Fully read and understand Section 4.8 with regards to safe driving practice.



**DANGER!** When the machine is lifted, the centre of gravity is raised and possibility of overturning is increased. Drive slowly and use extreme caution when turning on hillsides. Overturning the machine could result in the tractor and/or machine turning over resulting in serious injury or death.

Raise the machine sufficiently off the ground in order to give ground clearance over road obstacles, yet low enough to maintain on road stability.

This will ensure the best chance of safe transportation.

Make sure that the lower link chains are tight on the tractor before entering a public road to ensure the machine doesn't sway excessively, compromising safety to the tractor/operator, bystanders and other road users.



**WARNING!** Only carry the machine behind a properly sized and equipped tractor which exceeds the weight of the machine by at least 20%; see machine weights in Section 1.5.1.

**Never** carry the machine on any other type of vehicle. **Never** carry the machine at speeds over 20 mph (32 kmh).



**DANGER!** Never allow children or other persons to ride on the tractor or machine. Falling off can result in serious injury or death.



Figure 4.23 – Follow Safe Driving Practices

## 4.11 Transporting The Machine On A Trailer

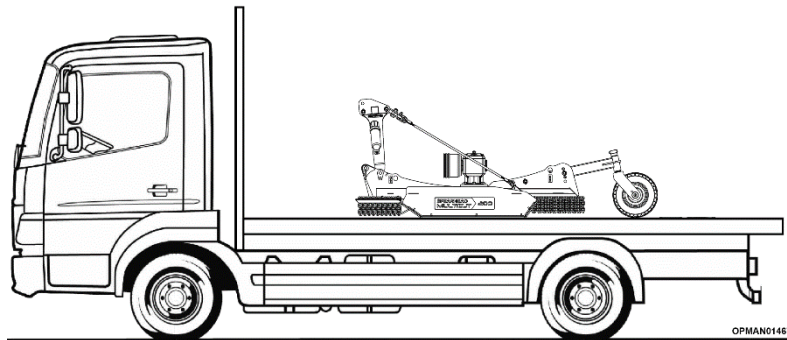

**Figure 4.24 – Transporting Machine On A Trailer**

Before transporting a machine (potentially plus tractor), measure the height and width dimensions and gross weight of the complete loaded unit. Ensure that the load will be in compliance with the legal limits set for the areas that will be travelled through during transit.

Use adequately sized and rated trailers and equipment to transport the tractor and machine. Consult an authorized dealer to determine the proper equipment required. Using adequately sized chains, heavy duty straps, cables and/or binders, securely tie down both the front and rear of the machine.

Arrange the straps so that when tightened, the straps are pulling downward and against themselves. Carefully tighten the securing strap or other fasteners to apply maximum tension and to ensure that no machine components get damaged. Use extreme care when attaching and removing the securing devices as the extreme tension involved when released has the potential to inflict serious injury.

While hauling the tractor and implement, make occasional stops to check that the machine has not moved or shifted and that the securing devices have maintained tension. If during transport a hard braking, sharp turning or swerving action was performed, stop at the next safe location to inspect the security of the load.



(This page is left blank intentionally)

## 5 Maintenance



**WARNING!** Before proceeding to carry out any maintenance on the Multicut machine, ensure that you have **thoroughly** read and understand Section 2.4 “Safe Maintenance” with regards to the correct and safe maintenance procedures of looking after the machine. This section gives safe guidance to ensure the wellbeing on the maintenance personnel as well as the machine itself.

### 5.1 Periodic Maintenance

Perform service, repairs, lubrication and maintenance procedures outlined throughout Section 5 to ensure the longevity and reliability of the Multicut machine.

In general:

- 5.1.1.1 Inspect for loose or missing fasteners, worn or broken parts, leaky or loose fittings, worn bushes and any other moving parts which are worn or missing.
- 5.1.1.2 Replace any worn or broken parts with genuine Spearhead parts under the guidance of the specific section stated in Section 5.
- 5.1.1.3 Lubricate the machines specified by the lubrication schedule as stated in Section 5.2.
- 5.1.1.4 **Never** lubricate, adjust or remove material while it is running or in motion.
- 5.1.1.5 Torque all bolts and nuts to the settings specified in Section 5.8.

### 5.2 Lubrication & Greasing



**CAUTION!** When working with/checking the driveline and lubrication system on the machine always wear safety glasses and impenetrable gloves. This also applies when working with the gearbox and gearbox oil. Use paper or cardboard to search for leaks and not hands or any other body parts.



**CAUTION!** Keep hands and body away from pin holes and nozzles ejecting hydraulic fluid and gearbox oil. Ingested or penetrated gearbox fluid in the body can become gangrenous. Removal must be carried out professionally by a suitable Doctor.

The mechanical components of the machine in use must be lubricated to avoid wear and heat build-up. Lubrication may be through the use of grease or oil. Oil allows higher relative speeds of items such as gearboxes, whereas grease is generally used to lubricate items such as bearings or bushes. In both cases it is important to ensure lubrication is given to these various items to ensure their longevity and reliability in use.

#### 5.2.1 Gearboxes



##### Equipment Required

- 85W-140 oil
- ¼” allen head socket/key

The gearboxes have been filled to the correct quantities prior to shipment. However, the oil level should be **checked on the dipstick or level plug before operating the machine for the first time and regularly thereafter**. It is important to fill and maintain the gearboxes with the correct quantities of oil. Overfilling the gearbox with oil does not improve lubrication and may cause overheating. Using an under filled gearbox can cause overheating and premature wear to components such as seals.

The quantity of oil to use in the gearbox is determined by the filling mark on the dipstick or the level plug and the guide quantity to the amount of oil required for the particular gearbox is given approximately in the table below.

Spearhead gearboxes are recommended to be filled with:  
Rotor Gearbox – **85W-140 grade oil**.

**Any different or higher SAE grade of oil is not recommended.**

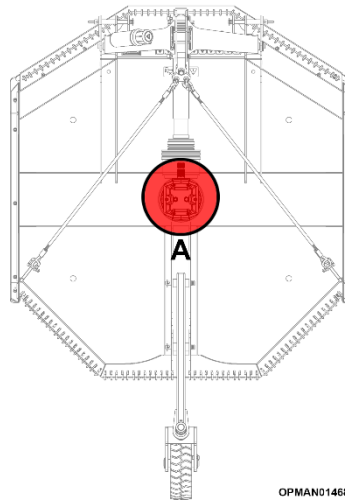

**Figure 5.1 - Multicut Gearbox Oil Capacity Locations**

	<b>Multicut 160/200</b>
<b>Rotor Gearbox (A)</b>	4.30 litres (9.09 pints)

**Table 5.1 – Multicut Gearbox Oil Capacities**

Changing the oil regularly prevents problems associated with deterioration, moisture build up in the oil and the potential presence of metallic particles which form early in the machines life. Oil changes are recommended on Multicut machines **after the first 50 hours**, and **then every 500 hours thereafter**.

To drain the oil, the gearbox is fitted with a **drain plug**; see Figure 5.2 (2). If there are facilities to vacuum draw the oil out of the gearbox, the oil can be changed through the fill hole/dipstick location instead which is considerably easier; see Figure 5.2 (1).

To check the oil level on the Multicut 160/200:

- The rotor gearbox utilises a dipstick which should be removed and visually inspected on the gauge to ensure the oil is up to the level mark: see Figure 5.2 (1)(3).

To add oil to the gearbox of the Multicut 160/200:

- With reference to Figure 5.2, to add additional oil, remove the dipstick (1) and fill through the dipstick hole. Continue to fill the gearbox to bring the level up to the upper mark (Figure 5.2 (3)) on the dipstick **before proceeding to use the machine**.

At all times the oil level should be above the lower fill mark; see Figure 5.2 (4) as otherwise permanent damage could be caused to the gearbox.

The gearbox should not require additional lubricant unless the box is cracked or a seal is leaking. It is recommended that the oil level is **checked every day before operation** and additional oil added if it's required.

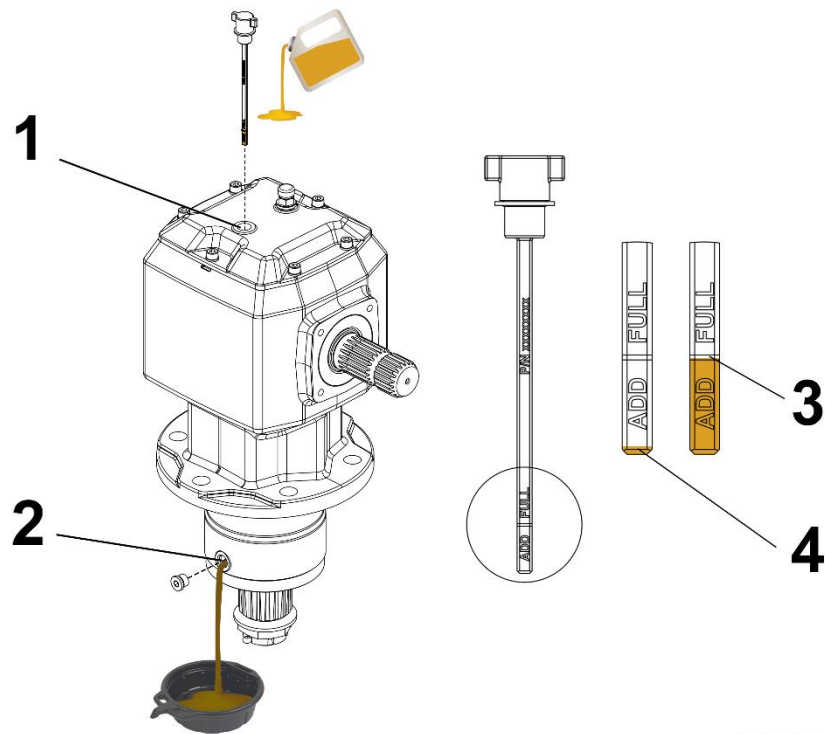

OPMAN00699

**Figure 5.2 – Multicut Rotor Gearbox**

No.	Description.
1	Dipstick
2	Drain Plug
3	Upper Fill Mark
4	Lower Fill Mark

**Table 5.2 – Multicut Rotor Gearbox Components**

## 5.2.2 PTO Shaft



### Equipment Required

- Manually operated grease gun supplying NLGI #2 Molybdenum Disulphide Grease to M6/M8 grease nipples
- 24mm hex socket/spanner

**IMPORTANT:** Proper and correct frequency of lubrication of all the rotating and sliding parts of the various PTO shafts fitted to the machine is essential for the correct function, longevity and reliability of the shaft. Insufficient lubrication or contamination is one of the most frequent causes of PTO shaft failure.

The joints, telescopic member and shields must be lubricated at intervals related to the environment and working conditions for the machine.

Bondioli & Pavesi recommend **NLGI #2 Molybdenum Disulphide Grease** on all crosses, telescoping members and shields. This grease contains additives which offer corrosion resistance, strength and adhesion at extreme pressures (EP) along with other benefitting properties.

When lubricating cross kits, pump grease until the grease purges from all four bearing caps. **Pump the grease gradually.** Avoid high pressures, especially those possible from pneumatic equipment.

The grease nipples on each end of the input shaft are accessible by rotating the plastic safety shield until the cut-out hole allows the grease point to be exposed.

Figure 5.3 shows each of the respective shafts for the various Multicut machines.

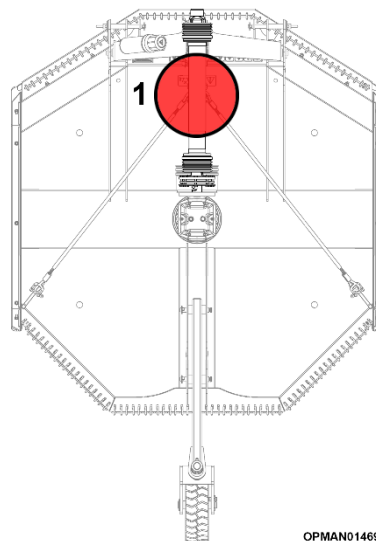

**Figure 5.3 – Multicut Input Shaft Type Locations**

Item No.	Shaft Type.
1	Input Shaft

**Table 5.3 – Multicut Input Shaft Type Locations**

**NOTE:** All values throughout this section are given on the assumption that a **manually operated grease gun** is used to carry out the greasing procedures giving a **predicted quantity of 0.8-1.0g of grease per pump.**

For reference to the required grease maintenance points on each of the respective shafts see below.



**WARNING!** It is mandatory to switch the combustion engine off and disengage PTO and ensure that the tractor and machine is stopped, the ignition key is removed from the dashboard and the parking brake is engaged before leaving the driver's seat and proceeding to carry out maintenance on any of the PTO shafts.

**Input Driveshaft (1)**

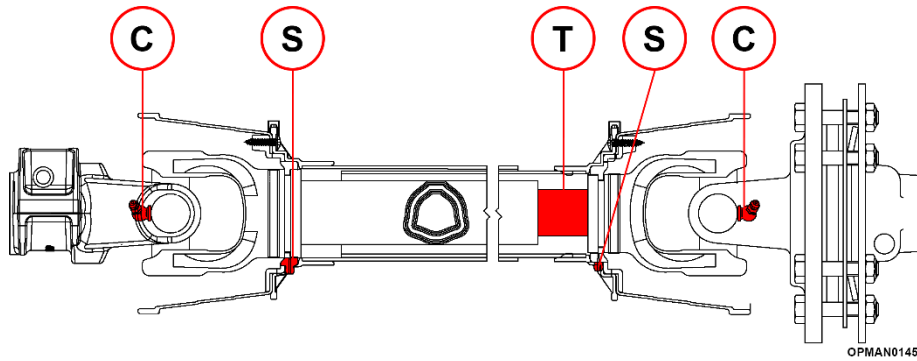

**Figure 5.4 – Multicut Input Shaft Grease Locations**

Model	PTO Input Speed (Shaft Size)	Quantity of Pumps		
		(C) - Cross	(S) – Shield Bearings	(T) – Telescopic Members
Multicut 160/200	540 (G7)	18	6	20

**Table 5.4 – Multicut Input Shaft Grease Quantities**

The “Quantity of Pumps” listed above are applicable to both the 6 spline and 21 spline Multicut 160/200 input driveshaft options.

**5.2.3 General Machine Greasing Point Locations**

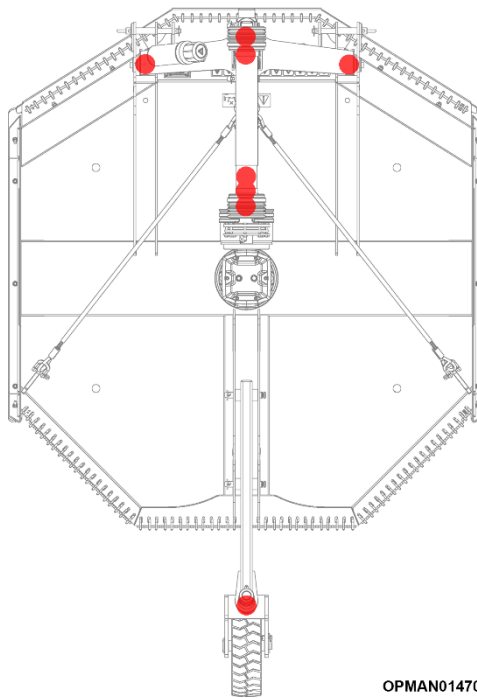

**Figure 5.5 – Multicut Grease Point Locations**

See Section 5.2.4 for reference to the routine greasing schedule for each of the relevant locations on the machine.

## 5.2.4 Greasing Schedule



### Equipment Required

- Manually operated grease gun supplying NLGI #2 Molybdenum Disulphide Grease to M6/M8 grease nipples

With reference to the position of grease points in Figure 5.5, the following greasing schedule should be adhered to, to ensure reliability and longevity in components.

**IMPORTANT:** With extended and harder working conditions, these greasing times may need to be shortened to compensate for the machine more intensive work requirements.

**NOTE:** All values throughout this section are given on the assumption that a **manually operated grease gun** is used to carry out the greasing procedures giving a **predicted quantity of 0.8-1.0g of grease per pump**.



**WARNING!** It is mandatory to switch the combustion engine off and disengage PTO and ensure that the tractor and machine is stopped, the ignition key is removed from the dashboard and the parking brake is engaged before leaving the driver's seat and proceeding to carry out maintenance on any of the PTO shafts.

Grease Point	Qty (pumps)	Frequency
Input PTO Shaft	See Section 5.2.2 - Input Shaft (1)	
Headstock	2	Every 8 hours
Wheel Arm	2	Every 8 hours

**Table 5.5**  
**Greasing Schedule For Various Components**

## 5.3 PTO Shaft

Spearhead Multicut machines feature Bondioli & Pavesi input PTO shafts. PTO shafts require routine maintenance and sometimes more demanding maintenance requirements to ensure their longevity and reliability of service.

For frequent greasing requirements of the various driveline shafts on the machine; see Section 5.2.2.

### 5.3.1 Size Adjustment & Fitting To The Tractor

The input PTO shaft supplied with the Multicut machine will be of standard supply as it came from the original manufacturer.

The input PTO shaft will be required to be modified/adjusted in order to fit the desired operating tractor. For guidance in how to carry this out; see Section 3.3.3.

For fitting the input PTO shaft between the machine and the tractor; see Section 4.4.

### 5.3.2 Greasing

For the greasing requirements on Multicut input driveshafts, refer to Section 5.2.2.

### 5.3.3 Input PTO shaft - Bearing Ring Replacement

Plastic wear bearing rings are found inside the PTO assembly to give a replaceable wearing surface between the metal PTO shaft and the outer plastic safety shield/cone. Due to the parts design aim, the wear rings inside the PTO assembly **will be required to be replaced over the working life of the PTO shaft** to ensure that the outer plastic safety shield/cone doesn't wear through and expose the rotating PTO shaft found inside.

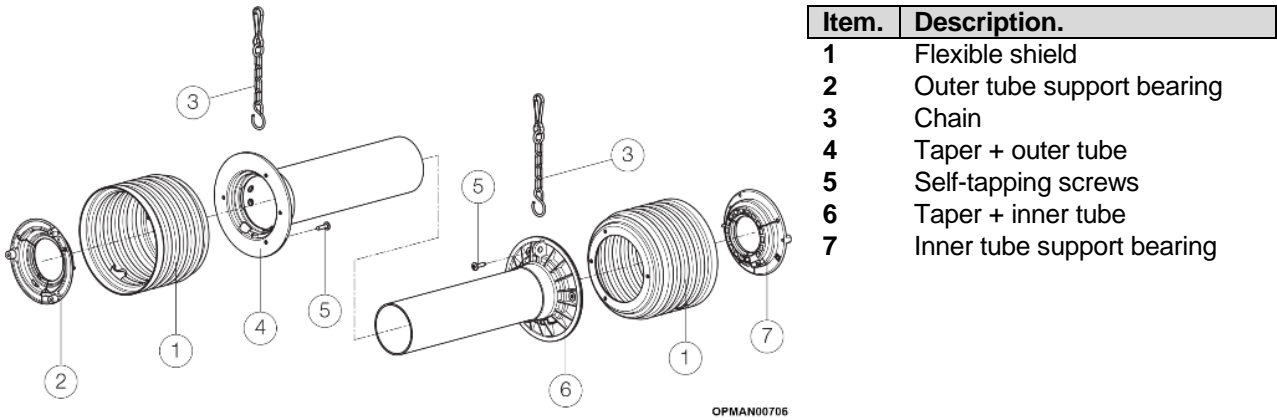
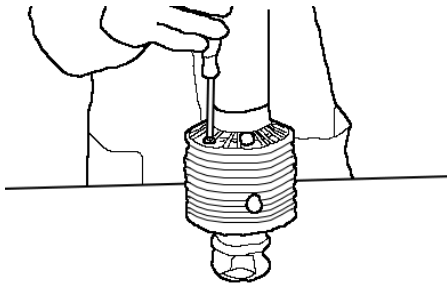

Figure 5.6/Table 5.6 - Input Shaft Safety & Wearing Components

Following this section will allow the successful removal and replacement of the bearing spacer wear rings.

### Input PTO shaft - Bearing Ring Replacement – DISASSEMBLY

	<b>Equipment Required</b>
	<ul style="list-style-type: none"> <li>• Phillips head screwdriver</li> </ul>



OPMAN06707

Figure 5.7

5.3.3.1 Remove the Phillips head screws

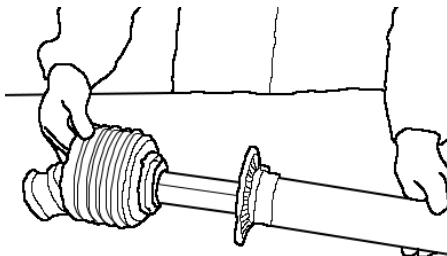

OPMAN06708

Figure 5.8

5.3.3.2 Remove the base cone and the shield tube



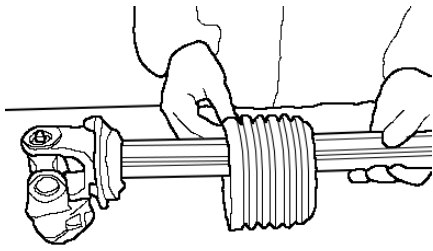

OPMAN00709 **Figure 5.9**

5.3.3.3 Remove the outer cone and bearing ring

**Input PTO shaft - Bearing Ring Replacement – REASSEMBLY**

	<p><b>Equipment Required</b></p> <ul style="list-style-type: none"> <li>• Phillips head screwdriver</li> <li>• NLGI #2 Molybdenum Disulphide grease with paint brush/distributor</li> </ul>
--	---

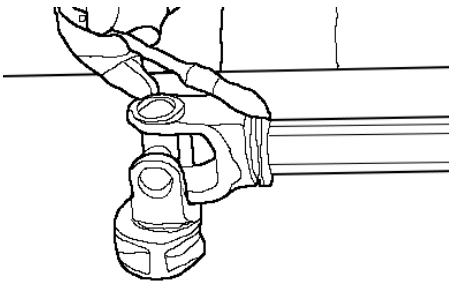

OPMAN00710 **Figure 5.10**

5.3.3.4 Grease the bearing groove on inner yokes

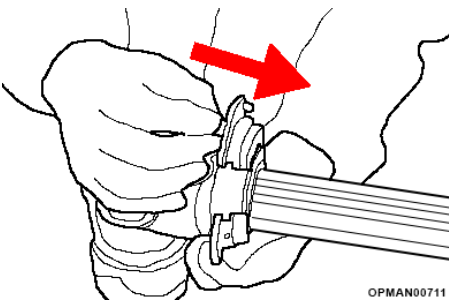

OPMAN00711 **Figure 5.11**

5.3.3.5 Fit the bearing ring into the groove with the reference pin facing the drive tube

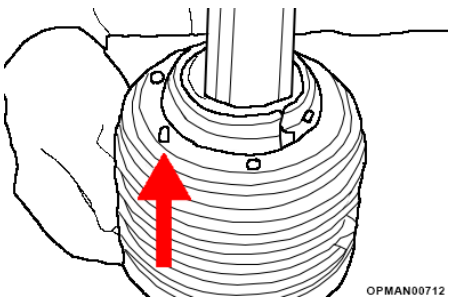

OPMAN00712 **Figure 5.12**

5.3.3.6 Fit the outer cone, inserting the reference pin of the bearing in the hole provided in the cone

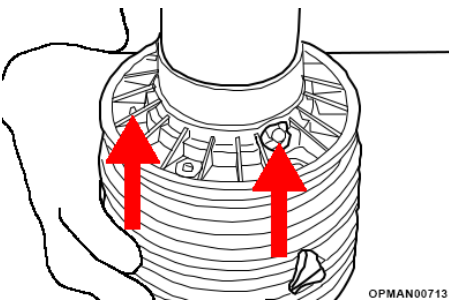

OPMAN00713 **Figure 5.13**

5.3.3.7 Fit the base cone with the tube, inserting the reference pin and the grease fitting of the bearing in the holes provided in the cone

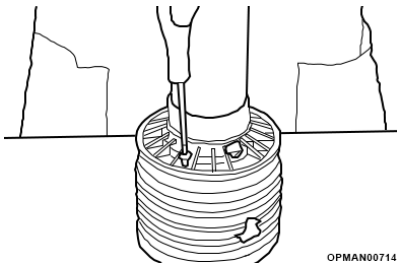

5.3.3.8 Tighten the Phillips head screws. Use of electric powered screwdrivers is not recommended

OPMAN00714 **Figure 5.14**

## 5.4 Slip Clutch

To prevent gearbox damage the rotor is protected by a slip clutch fitted to the input driveshaft. FV friction slip clutches are found on the Multicut machine range, equipped with special Belleville springs designed to apply pressure that varies with the amount of compression.

In use, the compression of the spring **has to be adjusted periodically to compensate for lining wear and to maintain the correct clutch setting**. Clutch settings are stated in Section 5.4.3 for each of the respective Multicut machines.

### 5.4.1 Slip Clutch Disassembly & Servicing

#### Breakdown Of Components

Multicut 160/200 machines feature a 200mm clutch with 2 friction linings. They have metal surfaces that are specially treated to help prevent sticking and corrosion of the friction linings.

Figure 5.15 gives a full breakdown of the slip clutch.

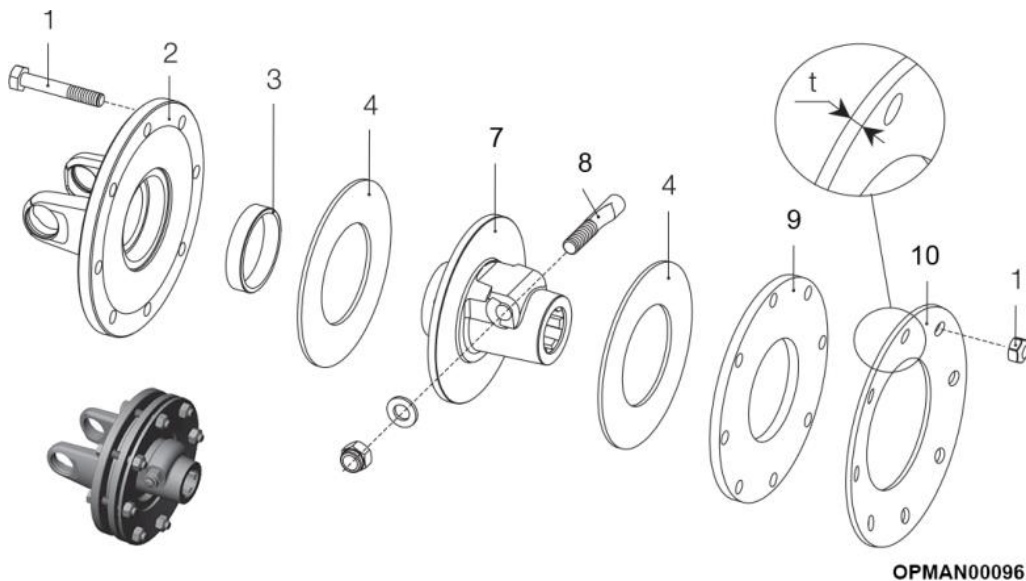

**Figure 5.15**

1	Bolt
2	Flange yoke
3	Bushing
4	Friction lining
5	Driving plate
6	Inner plate (sp=4mm)
7	Hub
8	Taper pin kit
9	Pressure plate
10	Belleville spring

**Table 5.7 – Slip Clutch Components**

## Disassembly

	<b>Equipment Required</b>
	• Digital Vernier caliper/micrometre
	• 19mm hex sockets/spanner
	• 2 x 17mm hex sockets/spanners

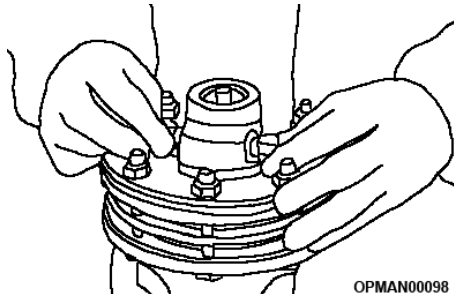

OPMAN0098

**Figure 5.16**

5.4.1.1 Remove the taper pin

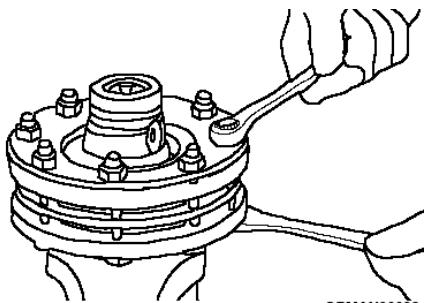

OPMAN0099

**Figure 5.17**

5.4.1.2 Unscrew progressively the 8 bolts in order to reduce the pressure uniformly on the discs and linings

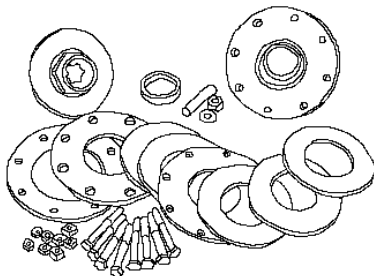

OPMAN00100

**Figure 5.18**

5.4.1.3 Remove the springs, discs and linings from the slip clutch

5.4.1.4 Verify the efficiency of all the parts of the slip clutch. Replace worn or damaged components with genuine Spearhead parts

**NOTE:** Clutch linings 'as new' thickness is 3.2mm. Replace the clutch linings when the thickness is reduced to 2.5mm.

Clean all metallic surfaces, especially those in contact with the clutch linings.

## Reassembly

	<p><b>Equipment Required</b></p> <ul style="list-style-type: none"> <li>• Digital Vernier caliper/micrometre</li> <li>• 19mm hex sockets/spanner</li> <li>• 2 x 17mm hex sockets/spanners</li> <li>• NLGI #2 Molybdenum Disulphide grease with paint brush/distributor</li> </ul>
---	---

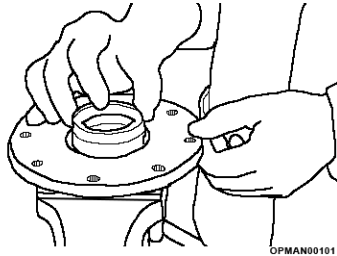

OPMAN00101  
**Figure 5.19**

- 5.4.1.5 Apply a film of grease on the bushing surfaces and insert it into the flange yoke. Avoid excessive grease on the bushing

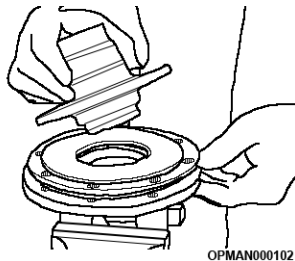

OPMAN000102  
**Figure 5.20**

- 5.4.1.6 Assemble in sequence the other parts as shown in Figure 5.15

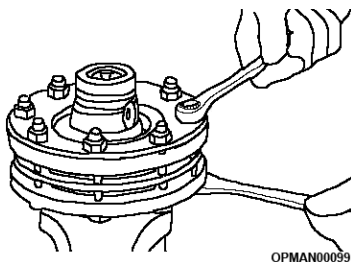

OPMAN00099  
**Figure 5.21**

- 5.4.1.7 Insert the 8 screw with their heads on the flange yoke side

- 5.4.1.8 Turn all the nuts in contact with the spring

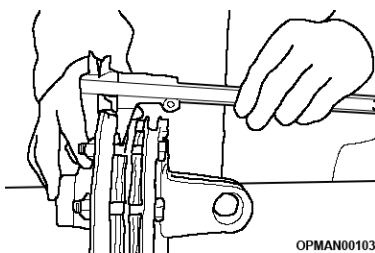

OPMAN00103  
**Figure 5.22**

- 5.4.1.9 Tight progressively the bolts (e.g. half a turn per time) in order to uniformly compress the Belleville spring to its required compression "h"; see Figure 5.24

For slip clutch settings see Section 5.4.3 and select the correct machine/particular shaft required. The clutch setting is listed under column "h"

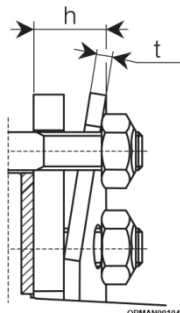

OPMAN00104  
**Figure 5.23**

**IMPORTANT:** Do not over-tighten the bolts; this may endanger the function of the clutch.

**IMPORTANT:** Spearhead recommends to not modify the torque settings given in Section 5.4.3. Damages to implement, driveline or tractor may occur. Spearhead declines all responsibility for damage to implement, driveline or tractor caused by modifying **any** slip clutch settings on Multicut machines in any other way than described in this manual. **If you are unsure of the procedure**, or need additional assistance, please **contact your local Spearhead dealer, qualified service centre or Spearhead**.

## 5.4.2 Freeing Seized Clutch Plates

	<p><b>Equipment Required</b></p> <ul style="list-style-type: none"> <li>• Digital Vernier caliper/micrometre</li> <li>• 2 x 17mm hex sockets/spanners</li> </ul>
---	--

If the machine has been **laid up for any length of time**, there is a risk of the clutch plates rusting and **seizing together**. Never operate the machine if it is in/potentially in this condition, as there will be no protection to the driveline and gearboxes against shock loading.

To free the clutch plates:

- 5.4.2.1 Slacken all compression spring bolts off the clutch plates; see Section 5.4.1.2.
- 5.4.2.2 Mark the outer plates in order to give a visual reference to if the clutch plates have freed or moved.
- 5.4.2.3 Run the machine **temporarily** in an aim to cause the clutch to slip with the tractor speed at around 1000 rpm.
- 5.4.2.4 Retighten the compression bolts to the correct distance; see Section 5.4.1.9.

**IMPORTANT:** Do not over-tighten the bolts; this may endanger the function of the clutch.

**If you are unsure of the procedure**, or need additional assistance, please **contact your local Spearhead dealer, qualified service centre or Spearhead**.

As a procedure to stop the above listed problem occurring, Spearhead recommends that the slip clutch is released when the machine is laid up for any longer than 7 days.

### 5.4.3 Clutch Settings

The tables listed out throughout this section give the settings for the various clutches on each of the Multicut machines.

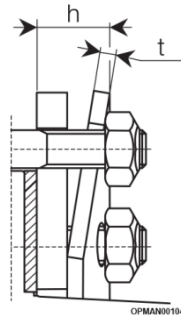

Figure 5.24 – Clutch Setting Dimension Guidance

### Multicut 160/200 Clutch Settings

PTO Speed	Shaft Part No.	Spline Quantity	Qty Plates/Size	Clutch Setting (h)*
				Standard
540 RPM	5770691	6	2 plate/200mm	18.5mm
	TBC	21	2 plate/200mm	18.5mm

Table 5.8

**NOTE:** The height “h” of the spring must be measured next to each bolt and may be  $\pm 0.2$ mm of the given value.

## 5.5 Blade/Chain Carriers, Blades, Chains & Anti-Scalp Dishes

### 5.5.1 Blade/Chain Carrier Options

Depending on the model of machine purchased, Multicut machines can come with two different cutting carrier set-ups; three blades or three chains.

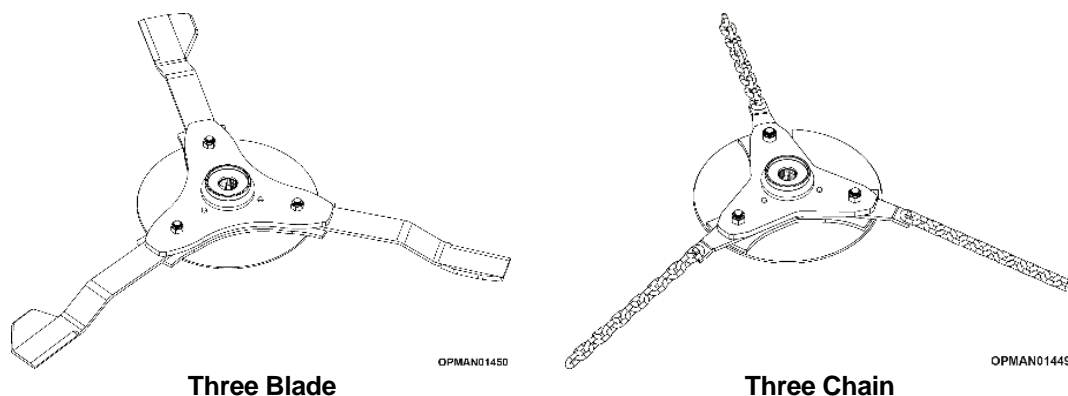
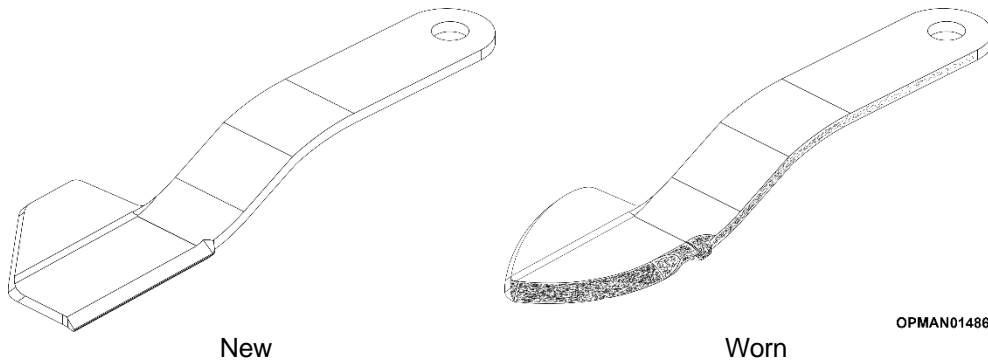

Figure 5.25 – Blade/Chain Carrier Options

## 5.5.2 Blade Inspection

**Inspect the machine blades before each use** to determine that they are properly installed, secure and in good condition. Replace any blade sets that are bent, excessively nicked, worn or have any other damage. If any blade is damaged it is important to replace **all** blades on that rotor to retain the balance of the particular rotor. Failure to replace such abnormally damaged blades may lead to catastrophic failure of the blade and ejection of the broken part with tremendous force which may cause bodily injury or death.

See Figure 5.26 shows the visual indications to look out for of worn blades.



**Figure 5.26 - Multicut Blades**



**DANGER!** When carrying out maintenance work on or near the blades be careful of free-swinging blades over-centering and falling. Ensure Personal Protection Equipment (PPE) is worn.



**WARNING!** Avoid personal injury. **Never work** under the machine without fixed support stands to ensure that the deck does not fall.

When servicing or inspecting blades of any type with the machine raised, **it is important to ensure that the blade carrier and blade assembly is moved into its “dropped” position** to ensure nothing suddenly falls due to the force of gravity. When the Multicut machine is raised this should automatically happen, but if it hasn't, hold the blades towards the outside and gradually rotate and pre-place them into their dropped position; as shown in Figure 5.27. This will ensure that personnel do not get hit by falling blades or pinched/trapped between the blade and the carrier.

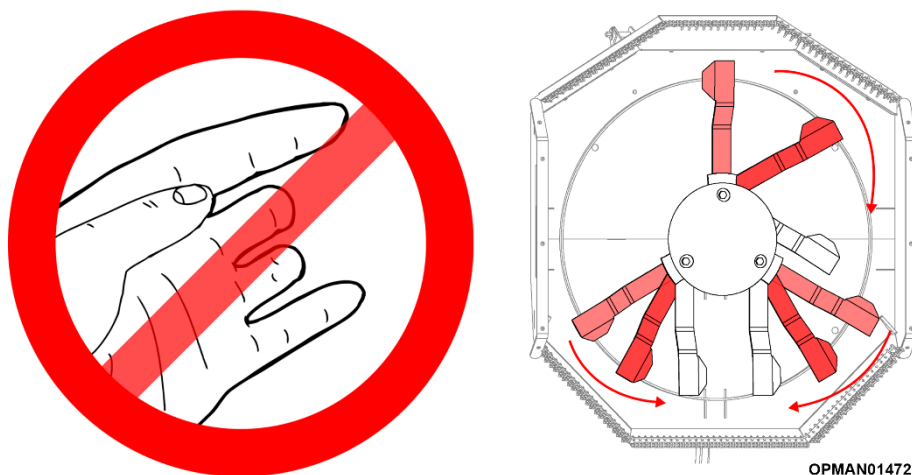

**Figure 5.27 – Beware Of Falling Blades**

Carefully wiggle the blade carrier assembly and check for looseness of fasteners. Retighten any loose parts to the correct torque figure. See Section 5.8 for torque settings. **Blade carrier fasteners should be checked after the first hour and then every 8 hours thereafter.**



#### **Equipment Required**

- Torque wrench (see required settings in Torque Settings section)
- 2 x 36mm hex sockets/spanner

**IMPORTANT:** Operating with loose blade components will damage the blade carrier and blades. Whenever the blades have been removed or replaced, the tightness of components should be checked after the first hour and then every 8 hours thereafter. It is of utmost importance that new fasteners and bushes are used on the reassembly. Blade fasteners and bushes are **single use items**.

When proceeding to inspect the blades, if any are showing any signs of severe wear, damage or cracking, they must be replaced immediately. Never attempt to weld the blades, as this will make them very brittle and dangerous. **Do not take risks with cutting blades – if in doubt replace.**



**WARNING!** Inspect the area before mowing. Foreign objects should be removed from the site prior to beginning work to prevent machine damage and/or operator, bystander or the environment. Any objects that cannot be removed must be clearly marked and carefully avoided by the operator.



**WARNING!** Pay special attention when working with the machine and do not allow the machine to touch fixed objects such as road drains, walls, shafts, curbs, guard rails, tracks etc. as these could break the blades or blade carrier which could cause debris to be thrown at very high speed from the machine. As a precaution raise the cutting height of the machine to 150mm (6 inches) to ensure they do not collide when the machine is in work.

As a preventative measure and to **reduce blade wear and potential detrimental damage, inspect the destined working area of the machine to determine where foreign object hazards are.** Remove these hazards and if they aren't easily removable, place visual markers where items are to ensure that the tractor and machine does not come into contact with these hazards.

**IMPORTANT:** Always use genuine Spearhead parts when carrying out repairs and maintenance with thoughts to longevity and reliability of the machine and personnel safety. Spearhead blades are made of special heat-treated alloy steel. Substitute blades may not meet specifications and may fail in a hazardous manner that could cause injury.

Spearhead declines all responsibility for damage and/or injury caused by use of **anything** other than the blade carriers/blades which are supplied with the machine as new or sold as a spare part replacement sold by a genuine Spearhead parts dealer on Multicut rotary machines.

See Section 7 for guidance on spare parts. The machine serial number will be required to be quoted. Serial plate location guidance can be found in Figure 1.4.

### **5.5.3 Chain Inspection**

**Inspect the machine chains before each use** to determine that they are properly installed, secure and in good condition. Replace any chain sets that are excessively worn, have any missing link or have any other damage. If any chain is damaged it is important to replace **all** chains on that rotor to retain the balance of the particular rotor. Failure to replace such abnormally damaged chains may lead to catastrophic failure of the chains and ejection of the broken part with tremendous force which may cause bodily injury or death.

Ensure chain wear does not exceed the following limits;

- For 13mm chains all links must have a minimum thickness of 10mm

See Figure 5.28 shows the visual indications to look out for of worn chains.



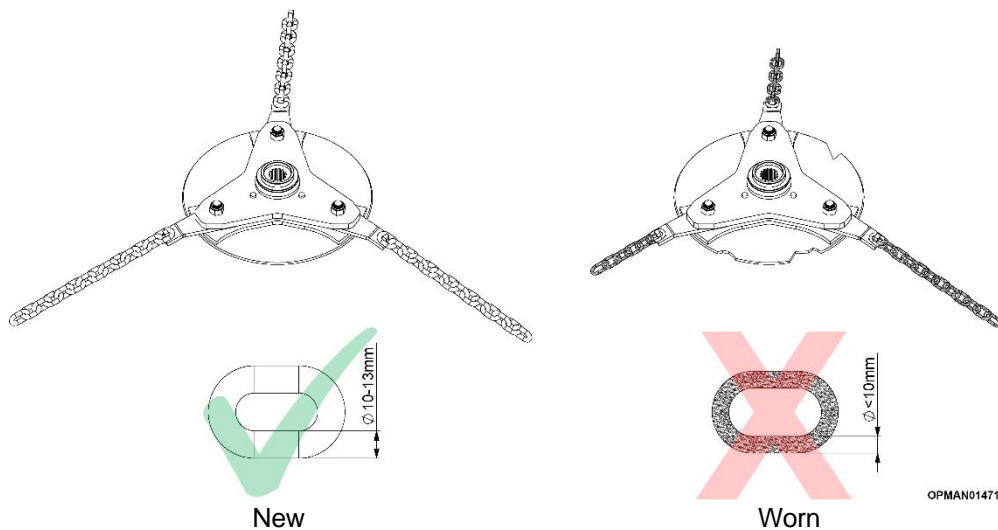

**Figure 5.28 - Multicut Chains**

Carefully wiggle the chain carrier assembly and check for looseness of fasteners. Retighten any loose parts to the correct torque figure. See Section 5.8 for torque settings. **Chain carrier fasteners should be checked after the first hour and then every 8 hours thereafter.**



**Equipment Required**

- Torque wrench (see required settings in Torque Settings section)
- 2 x 36mm hex sockets/spanner

**IMPORTANT:** Operating with loose chain components will damage the chain carrier. Whenever the chain have been removed or replaced, the tightness of components should be checked after the first hour and then every 8 hours thereafter. It is of utmost importance that new fasteners and bushes are used on the reassembly. Chain fasteners and bushes are **single use items**.

When proceeding to inspect the chains, if any are showing any signs of severe wear, missing links or have any other damage, they must be replaced immediately. **Do not take risks with cutting chains – if in doubt replace.**



**WARNING!** Inspect the area before mowing. Foreign objects should be removed from the site prior to beginning work to prevent machine damage and/or operator, bystander or the environment. Any objects that cannot be removed must be clearly marked and carefully avoided by the operator.



**WARNING!** Pay special attention when working with the machine and do not allow the machine to touch fixed objects such as road drains, walls, shafts, curbs, guard rails, tracks etc. as these could break the chains or chains carrier which could cause debris to be thrown at very high speed from the machine. As a precaution raise the cutting height of the machine to 150mm (6 inches) to ensure they do not collide when the machine is in work.

**IMPORTANT:** Always use genuine Spearhead parts when carrying out repairs and maintenance with thoughts to longevity and reliability of the machine and personnel safety. Substitute chains may not meet specifications and may fail in a hazardous manner that could cause injury.

Spearhead declines all responsibility for damage and/or injury caused by use of **anything** other than the chain carriers/chain which are supplied with the machine as new or sold as a spare part replacement sold by a genuine Spearhead parts dealer on Multicut rotary machines.

See Section 7 for guidance on spare parts. The machine serial number will be required to be quoted. Serial plate location guidance can be found in Figure 1.4.

## 5.5.4 Blade Sharpening & Straightening

Spearhead **does not** recommend sharpening worn blades. **It is important that all the blades on a rotor, are of the same weight and length and are all present** to ensure the rotor remains balanced. By sharpening blades there is a chance of them overheating, which will affect the hardness of the blades; compromising safety to the operator, machine and bystanders.



**DANGER!** Never attempt to straighten or weld on blades. This is likely to cause potential cracks and other damage to the blade. Subsequent failure and possible serious injury will occur from thrown blades.

**NOTE:** Spearhead declines all responsibility for damage and/or injury caused by sharpening/straightening and/or modifying blades on any Multicut machines. **If you are unsure of the condition** of your blades, and feel you need additional assistance, please **contact your local Spearhead dealer, qualified service centre or Spearhead.**

## 5.5.5 Blade/Chain Removal & Replacement



### Equipment Required

- Torque wrench (see required settings in Torque Settings section)
- 36mm hex sockets/spanner
- 36mm hex spanner



**WARNING!** It is mandatory to switch the combustion engine off and disengage PTO and ensure that the tractor and machine is stopped, the ignition key is removed from the dashboard and the parking brake is engaged before leaving the driver's seat and proceeding to adjust the levelling of the machine.

Before proceeding to remove and replace the blades or chains of the machine, correctly assess the condition of the blades and chains by reading the guidance given in Sections 5.5.2 and 5.5.3.

If blade or chain replacement is required, in order to not need to remove the lower blade/chain carrier of the rotor, remove and replace each of the blades/chains of the machine one at a time. When replacing rotor assemblies with new blades/chains, due to their free swinging ability, **it is important to fit new hardened bushes into the blades/chains at the same time.** This can ensure the rotor is remained balanced. **Blade bolts and nuts should be replaced whenever blades and bushes are removed;** whether the blades are requiring replacement or not.

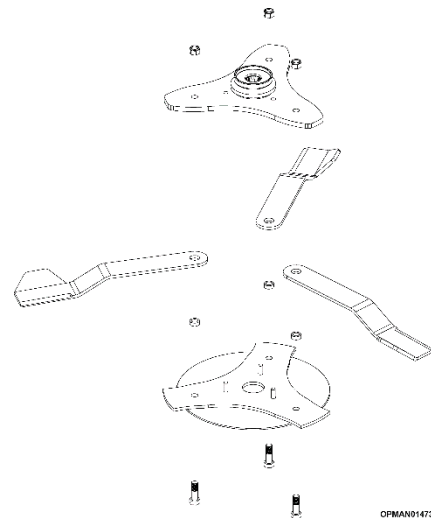

**Figure 5.29 – Multicut Blade Carrier Assembly**

Figure 5.21 shows the selection of different Multicut 160/200 blades, chains and fasteners for the various specification machines available from Spearhead Machinery.

The correct quantities for blade and chain setups for Multicut 160 and Multicut 200 model machines are specified in Table 5.9 and Table 5.10.

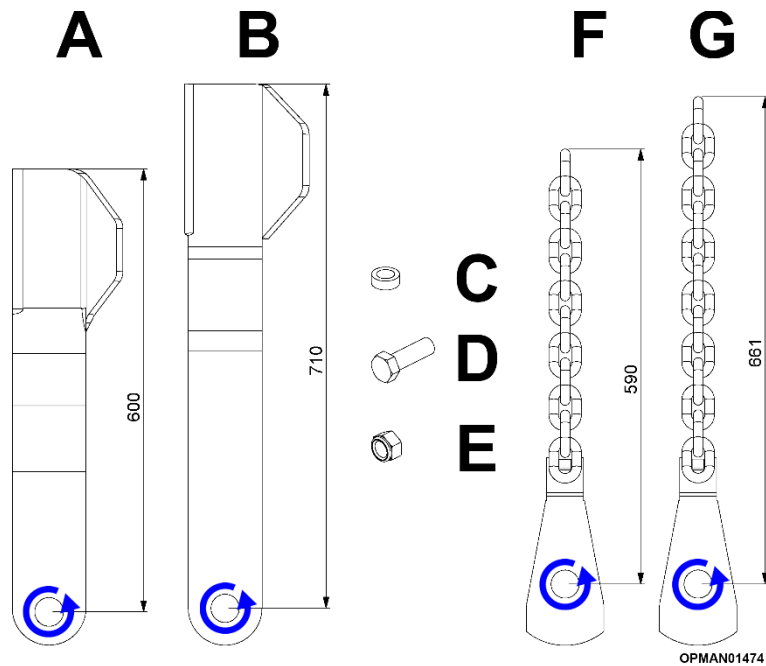

**Figure 5.30**  
**Multicut Range Blade & Chain Components**

### Blade Quantities

Blade		Quantity Required	
		Multicut 160	Multicut 200
A	7770700	3	-
B	7770718	-	3
C	7770707	3	3
D	2770413	3	3
E	2770414	3	3

**Table 5.9**

### Chain Quantities

Chain		Quantity Required	
		Multicut 160	Multicut 200
C	7770707	3	3
D	2770413	3	3
E	2770414	3	3
F	7770582	3	-
G	7770584	-	3

**Table 5.10**

## 5.5.6 Blade/Chain Bolt Inspection

Blade/Chain bolts are prone to getting damaged when coming in contact with foreign or solid objects which can seriously compromise the wellbeing of machine, the operator and bystanders. Neglecting damaged blade/chain bolts can cause serious injury or death.

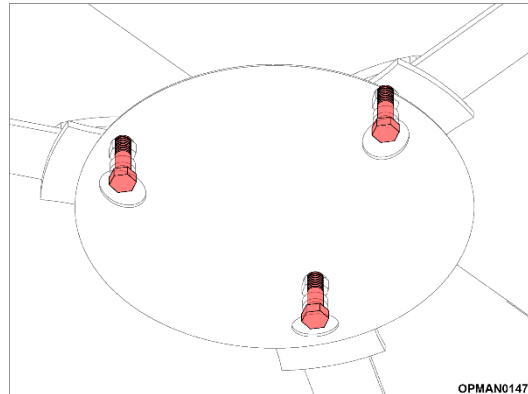

**Figure 5.31**  
(Blades Fitted)

Inspect the heads of blade/chain bolts daily for:

- Visible cracks
- Wear on the recessed area of the head of the bolt
- Gouges and chipped areas



**DANGER!** Failure to inspect daily and replace worn or damaged blade/chain bolts may lead to catastrophic failure of the blades/chains and ejection of the broken part which may cause serious bodily injury or death.

If any of these visual damages are found, replace **all blade/chain bolts, nuts and bushes** on that rotor **immediately**.

**IMPORTANT:** Always replace blade/chain bolts, nuts and bushes with new components whenever the machine blades/chains are removed and/or replaced.



**WARNING!** Inspect the area before mowing. Foreign objects should be removed from the site prior to beginning work to prevent machine damage and/or operator, bystander or the environment. Any objects that cannot be removed must be clearly marked and carefully avoided by the operator.



**WARNING!** Pay special attention when working with the machine and do not allow the machine to touch fixed objects such as road drains, walls, shafts, curbs, guard rails, tracks etc. as these could break the blades/chains which could cause debris to be thrown at very high speed from the machine. As a precaution raise the cutting height of the machine to 150mm (6 inches) to ensure they do not collide when the machine is in work.

As a preventative measure inspect the destined working area of the machine to determine where foreign object hazards are. Remove these hazards and if they aren't easily removable, place visual markers where items are to ensure that the tractor and machine does not come into contact with these hazards.

### 5.5.7 Anti-scalp Dish Inspection

An anti-scalp dish is found on the bottom of the rotor of the machine to protect the blades/chains and the driveline. However, like the blades/chains its potentially prone to coming into contact with immovable objects while the machine is in work. **Inspect the machine anti-scalp dish before each use to determine that its are properly installed, secure and in good condition. Replace blade/chain carriers which are excessively nicked, worn or have any other damage.**

See Figure 5.32 for some visual indications of a worn anti-scalp dish lower blade/chain carrier.

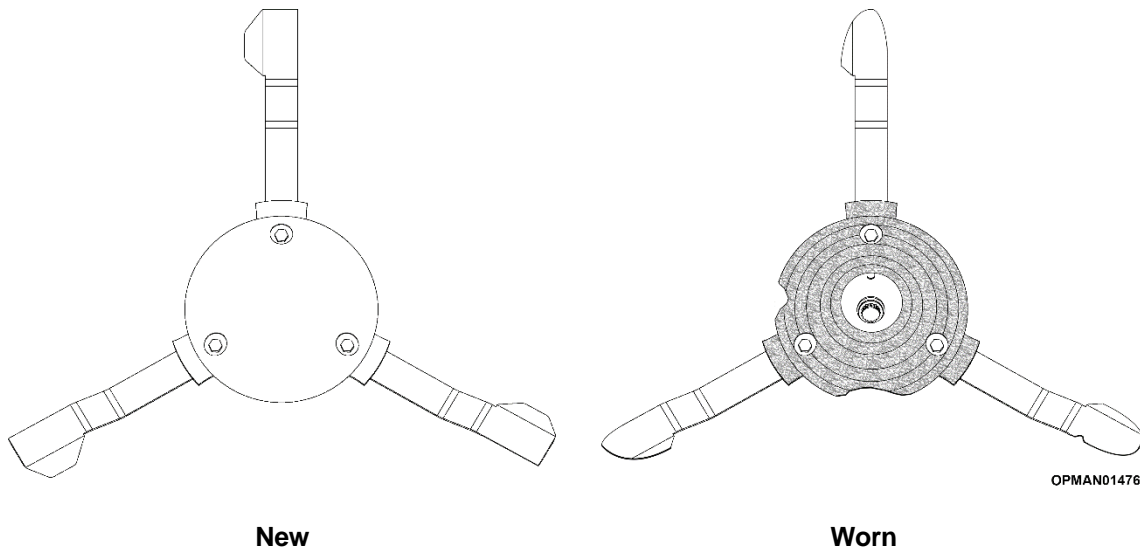

New

Worn

**Figure 5.32**  
**New vs Worn Anti-scalp Dish Comparison**  
 (Blade set-up shown)



**DANGER!** When carrying out maintenance work on or near the blade/chain carrier be careful of free-swinging blades/chain over-centering and falling. It is recommended that Personal Protection Equipment (PPE) is worn.



**WARNING!** Avoid personal injury. **Never work** under the machine without fixed support stands to ensure that the deck does not fall.

When servicing or inspecting blades/chains of any type with the machine raised, **it is important to ensure that the blade/chain carrier and blade/chain assembly are moved into their “dropped” position** to ensure nothing suddenly falls due to the force of gravity. When the Multicut machine is raised this should automatically happen, but if it hasn't, hold the blades/chains towards the outside and gradually rotate and pre-place them into their dropped position; as shown in Figure 5.33. This will ensure that personnel do not get hit by falling blades/chains or get pinched/trapped between the blade/chain and the carrier.

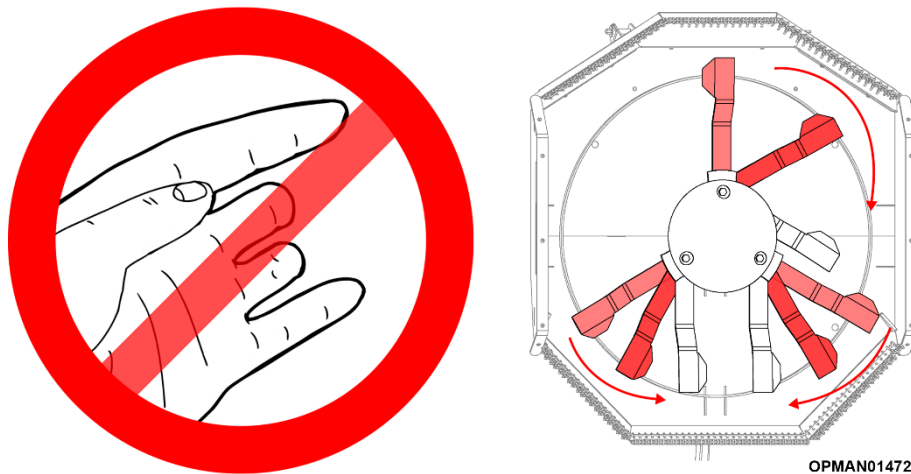

**Figure 5.33 – Beware Of Falling Blades/Chains**  
(Blades assembly shown)



#### **Equipment Required**

- Torque wrench (see required settings in Torque Settings section)
- 2 x 36mm hex sockets/spanner

Carefully wiggle the blade/chain carrier assembly and check for looseness of fasteners. Retighten any loose parts to the correct torque figure. See Section 5.8 for torque settings. **Blade/chain carrier fasteners should be checked after the first hour and then every 8 hours thereafter.** It is of utmost importance that new fasteners and bushes are used on the reassembly. Blade/chain fasteners and bushes are single use items.

**IMPORTANT:** Operating with loose blade/chain components will damage the blade/chain carrier and blades/chains. Whenever the blades/chains have been removed or replaced, the tightness of components should be checked after the first hour and then every 8 hours thereafter.



**WARNING!** Inspect the area before mowing. Foreign objects should be removed from the site prior to beginning work to prevent machine damage and/or operator, bystander or the environment. Any objects that cannot be removed must be clearly marked and carefully avoided by the operator.



**WARNING!** Pay special attention when working with the machine and do not allow the machine to touch fixed objects such as road drains, walls, shafts, curbs, guard rails, tracks etc. as these could break the blades/chains or blade/chain carrier which could cause debris to be thrown at very high speed from the machine. As a precaution raise the cutting height of the machine to 150mm (6 inches) to ensure they do not collide when the machine is in work.

As a preventative measure and to reduce blade/chain and blade/chain carrier wear and potential detrimental damage, inspect the destined working area of the machine to determine where foreign object hazards are. Remove these hazards and if they aren't easily removable, place visual markers where items are to ensure that the tractor and machine do not come into contact with these hazards.

**IMPORTANT:** Always use genuine Spearhead parts when carrying out repairs and maintenance with thoughts to longevity and reliability of the machine and personnel safety. Spearhead blade/chain carriers are made of special heat-treated alloy steel. Substitute blade/chain carriers may not meet specifications and may fail in a hazardous manner that could cause injury.

Spearhead declines all responsibility for damage and/or injury caused by use of **anything** other than the blade/chain carrier and components which are supplied with the machine as new or sold as a spare part replacement sold by a genuine Spearhead parts dealer on Multicut rotary machines.

See Section 7 for guidance on spare parts. The machine serial number will be required to be quoted. Serial plate location can be found in Figure 1.4.

## 5.5.8 Anti-scalp Dish, Blade/Chain & Blade/Chain Carrier Removal & Replacement

**IMPORTANT:** Throughout this section be aware of the blade/chain carrier and blades/chains rotating. Before proceeding to carry out any of the operations stated in this section; see Section 5.5.7 with regards to handling blade/chain carrier assemblies safely.

### Anti-scalp Dish, Blade/Chain & Blade/Chain Carrier Removal

	<b>Equipment Required</b>
	• Torque wrench (see required settings in Torque Settings section)
	• 36mm hex sockets/spanner
	• 36mm hex spanner
	• 55mm hex spanner
	• Needle nose pliers

\*NOTE\* Throughout this section, the process is shown removing and replacing a full blade and blade carrier assembly. For complete clarity the exact same process is applicable to an equivalent chain and chain carrier assembly.

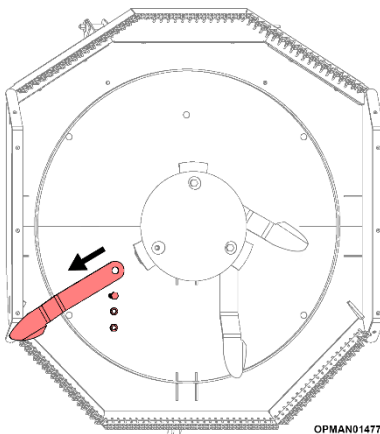

Figure 5.34

- 5.5.8.1 Before proceeding to carry out any work ensure that the blades and blade carrier are in their “dropped” and in a stationary position on both rotors.

Ensuring that you’re wearing suitable gloves, proceed to loosen the fasteners on the first blade and carefully remove the bolt, bush, nut and blade.



**DANGER!** When carrying out maintenance work on or near the blade carrier, be careful of free-swinging blades over-centering and falling. It is recommended that Personal Protection Equipment (PPE) is worn.

If an anti-scalp dish replacement is required proceed to 5.5.8.5.

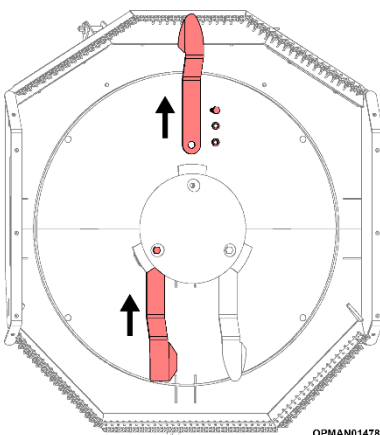

Figure 5.35

- 5.5.8.2 If the maintenance required is simply a blade replacement and the blade carrier is still in good condition, proceed to install the new blade, with an accompanying new bolt, bush and nut.

It is of **upmost importance** that new fasteners and bushes are used on the reassembly. Blade fasteners and bushes are **single use items**.

- 5.5.8.3 Torque the new fasteners to the recommended torque as stated in Section 5.8.

- 5.5.8.4 Repeat processes 5.5.8.1 to 5.5.8.3 in the same way on the second and third blades.

It is important that **if a new blade is fitted that the other blades are also replaced with new items**. This is to ensure that the

rotor when in operation does not experience issues with vibration.

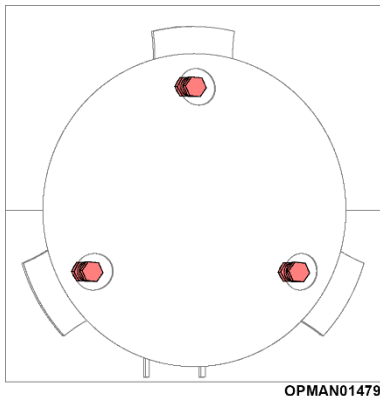

OPMAN01479

**Figure 5.36**

5.5.8.5 If a lower blade carrier is required to be replaced as well as the blades, remove a blade and replace the removed fasteners and loosely tighten up again. Repeat the process on the other two blades.

5.5.8.6 Proceed to remove each of the blade fasteners, firmly holding the blade carrier as you do so and remove the blade carrier.

Spearhead recommends removing the blades and carrier as two separate processes as the safest way in removing lower blade carriers. It removes the danger of the falling blades and allows personnel the easiest and safest way of managing the task with heavy items.

5.5.8.7 Inspect the upper blade carrier for damage and flatness.

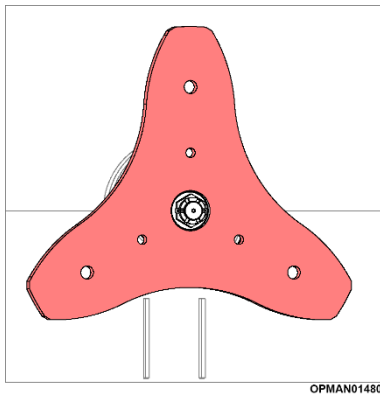

OPMAN01480

**Figure 5.37**



OPMAN01482

**Figure 5.38**

5.5.8.8 To remove the upper blade carrier, use needle nosed pliers to unbend the cotter pin found slotted through the output shaft of the gearbox/castle nut and remove it.

Loosen the castle nut and fully remove all accompanying components. Gently slide the carrier from the splines of the output shaft of the gearbox. Inspect the splines for damage on both the upper blade carrier and the gearbox output shaft.

5.5.8.9 Inspect the underside of the gearbox and for damage and caught up debris.

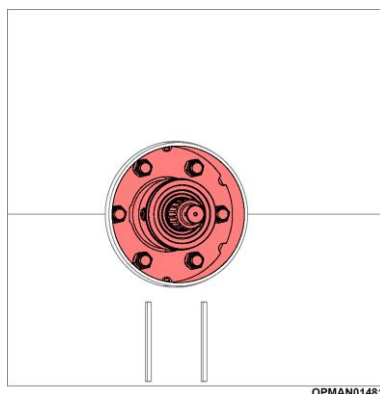

OPMAN01481

**Figure 5.39**



## Anti-scalp Dish, Blade & Blade Carrier Installation

	<p><b>Equipment Required</b></p> <ul style="list-style-type: none"> <li>• 36mm hex sockets/spanner</li> <li>• 36mm hex spanner</li> <li>• 55mm hex spanner</li> <li>• Needle nose pliers</li> <li>• NLGI #2 Molybdenum Disulphide grease with paint brush/distributor</li> </ul>
---	--

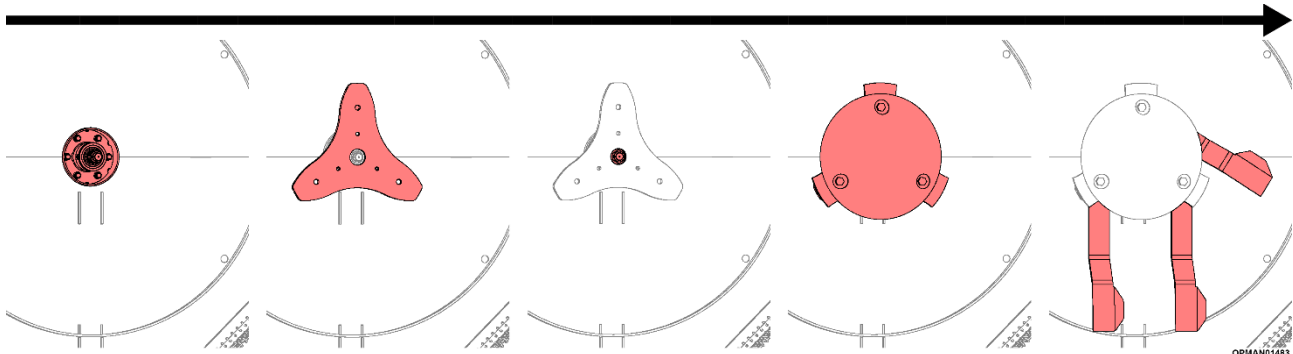

**Figure 5.40**  
**Anti-scalp Dish, Blade & Blade Carrier Installation**

The complete blade and blade assembly can be reassembled in a reverse order to what is described in the removal procedure.

**Always** assess the condition of all the components to see they're fit for purpose before reassembling.

- See Section 5.5.2 for assessing the condition of the machine cutting blades.
- See Section 5.5.3 for assessing the condition of the machine cutting chains.
- See Section 5.5.7 for assessing the condition of the machine anti-scalp lower blade/chain carrier.

Before reassembling the blade and blade carrier assembly assess the gearbox seal ensuring it is in good condition and undamaged. Ensure there is no ingressed wire or other material in this area. Before reassembly in general ensure that all components are checked for their condition and cleanliness. Failure to do this may result in personal injury and permanent damage to the machine and/or tractor.



**DANGER!** Failure to replace a worn or damaged gearbox shaft and/or upper blade carrier may lead to catastrophic failure of the carrier assembly and ejection of broken parts which may cause serious bodily injury or death.

Always replace blade bolts and nuts and blade bushes with brand new items whenever blades are removed and/or replaced. For torque settings on the components; see Section 5.8.

When fitting the upper blade carrier to the gearbox shaft ensure that there is no play between the splines. **If in doubt replace.** Neglecting play in a worn gearbox shaft and/or upper blade carrier splines can cause serious injury or death. It can also create abnormal vibrations in the machine which in turn can damage other machine components.

**IMPORTANT:** Stop and do not use the machine when there is vibration in the machine, as this may cause breakage and serious damage. Find the cause of the vibration or have it inspected by personnel assigned by Spearhead and do not use the machine until the cause is identified and eliminated.

**IMPORTANT:** Always replace blade bolts and nuts and blade bushes with brand new items whenever blades are removed and/or replaced. For torque settings on the components; see Section 5.8.

**IMPORTANT:** Always use genuine Spearhead parts when carrying out repairs and maintenance with thoughts to longevity and reliability of the machine and personnel safety. Genuine Spearhead parts are made to specific standards to give performance and safety. Substitute components may not meet specifications and may fail in a hazardous manner that could cause injury.

Spearhead declines all responsibility for damage and/or injury caused by use of **anything** other than the genuine Spearhead parts on Multicut rotary machines.

See Section 7 for guidance on spare parts. The machine serial number will be required to be quoted. For guidance on finding the serial plate location; see Figure 1.4.

## 5.6 Wheel, Hub & Tyre

	<p><b>Equipment Required</b></p> <ul style="list-style-type: none"> <li>• Torque wrench (see required settings in Torque Settings section)</li> <li>• 2 x 19mm hex sockets/spanner</li> <li>• 10mm allen head socket/key</li> <li>• Nylon hammer</li> </ul>
---	---

Before installing/removing the wheel and tyre, make certain that the machine is jacked up high enough for them to be easily fitted and to ensure that the machine is securely supported with fixed supports so it cannot move.

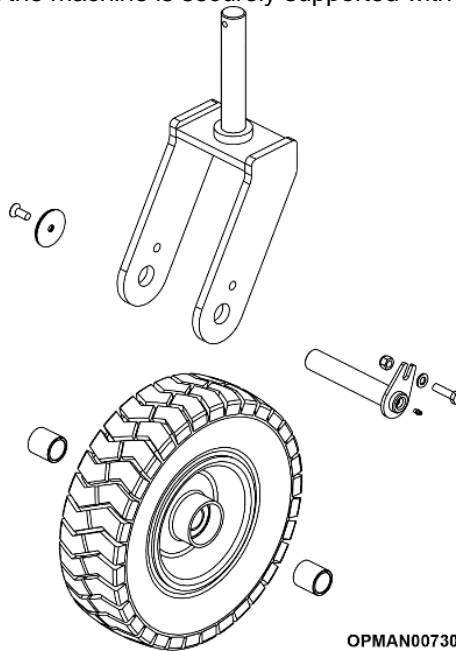

**Figure 5.41 – Multicut Wheel & Fork Assembly**

**IMPORTANT:** Do not use any other wheel/tyre than those recommended/supplied by Spearhead. Spearhead declines all responsibility for damage and/or injury caused by use of **anything** other than the wheel/tyre which was supplied with the machine as new or sold as a spare part replacement sold by a Spearhead dealer on Multicut rotary machines. **If you are unsure of the correct wheel/tyre for the machine, or need additional assistance, please contact your local Spearhead dealer, qualified service centre or Spearhead.**

### 5.6.1 Tyre Pressures

	<p><b>Equipment Required</b></p> <ul style="list-style-type: none"> <li>• Air supply with Schrader valve</li> </ul>
---	---

Tyre pressures should be **checked weekly** and when they're cold to ensure their longevity and wellbeing as well as the safety and stability of the machine in use and to ensure level cutting when the machine is in work.

Machine Model.	Tyre Type.	Tyre Pressure.
Multicut 160/200	Forklift truck tyre	50 psi/3.45 bar

**Table 5.11 – Multicut Tyre Pressures**

## 5.6.2 Hub Greasing

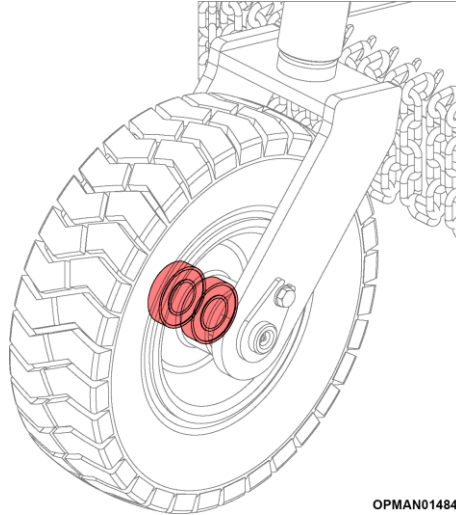

**Figure 5.42 – Multicut Wheel Bearing**

The Multicut 160/200 wheel hubs feature sealed bearings. These require no weekly maintenance, however still require a regular inspection of the condition of the bearings to ensure no rumble or excessive play is apparent.

## 5.7 Other Key Components



**IMPORTANT:** Before starting, safety checks on tractor and machine must be carried out with regard to: functionality, road safety and accident prevention rules.

### 5.7.1 Pins & Bushes

#### Pins

Pins should be inspected regularly to ensure they are not worn, damaged or loose.

Ensure all pins and accompanying fasteners are tight and routinely checked following the guidance given on the Maintenance Sheet; see Section 5.9.

Ensure that the pins have not been worn in such a way to create a step. Make sure the pin is not bent and the head is not damaged. If in any doubt, replace.

#### Bushes

The machine should be inspected regularly to ensure the bushes are not worn. Worn bushes should be replaced when there is excess movement. Bushes will wear oversize or oval.

### 5.7.2 Skids



#### Equipment Required

- 8mm allen head socket/key
- 17mm hex socket/spanner

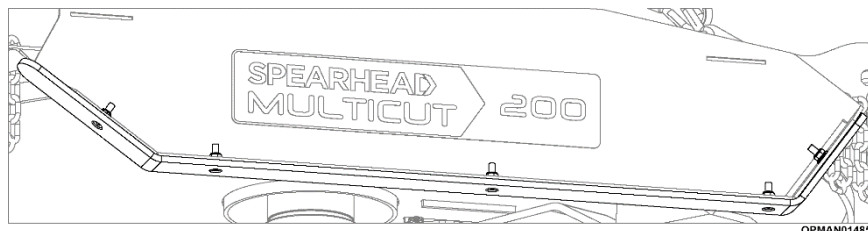

**Figure 5.43 – Multicut Wing Skid**

Spearhead machine skids are fitted to protect the machine deck fabrications from permanent damage. Premature wear can be caused to the skids through the machine being set too low, allowing the skids to drag along the ground causing an earlier requirement for replacement. Dragging the skids on the ground or running the skids into solid objects can contribute to early frame failure of the machine. Replace worn skids as required. **Failure to replace skids and using the machine without will cause permanent damage to the deck fabrications.**

## 5.8 Torque Settings

### 5.8.1 Nuts & Bolts

#### Specific Fastener Requirements

On Multicut machines, there are some special fasteners/components which require specific torque settings to ensure they operate safely.

Use	Size	Grade	Torque Setting	
			Nm	Ft-lb
Rotor Gearbox Bolts	M20	8.8	500	369
Blade Bolts	M24	8.8	950	700

**Table 5.12 – Multicut Specific Fastener Torque Settings**

#### Non-specific Fastener Requirements

The below tables give reference to the **maximum** recommended tightening torques for standard, zinc plated finished bolts on Spearhead machines. **These settings can be applied to hex, socket countersunk and socket button screws.**

Size	Grade					
	8.8		10.9		12.9	
	Nm	Ft-lb	Nm	Ft-lb	Nm	Ft-lb
M5	5	3	7	5	8	6
M6	14	10	12	9	14	10
M8	34	25	29	21	34	25
M10	68	50	57	42	68	50
M12	119	88	99	73	119	88
M14	189	139	158	116	189	139
M16	295	218	246	181	295	218
M18	406	299	338	249	406	299
M20	576	424	480	354	576	424
M22	783	577	652	481	783	577
M24	995	734	829	612	995	734
M30	1977	1458	1647	1215	1977	1458

**Table 5.13 – Standard Fastener Torque Settings**

### 5.8.2 Other Items

Use	Torque Setting	
	Nm	Ft-lb
Input Shaft Taper Pin	230	170

**Table 5.14 – Multicut Specific Fastener Torque Settings**

## 5.9 Machine Inspection Record

	<b>MACHINE INSPECTION RECORD</b> <b>(For Multicut 160/200)</b>	Pre-delivery inspection:	Select
		Installation inspection:	Select
		Daily pre-work inspection:	Select
Model:	Serial No:		
Inspector name (print):	Inspection date:		
Company/Position:			
Inspector signature:			
Visual Checks		Comments	OK
Check that an operator's instruction manual in the correct language for the working territory is in the machine document holder.			
Check that the operator's instruction manual is filled in and serial number is present and matches the serial number of the machine.			
Inspect main fabrications for damage – deck, wheel arm, headstock.			
Inspect the headstock to ensure that it can move freely when in work			
Inspect the headstock wire rope ensuring that there is sufficient slack in order to allow the headstock to float in work			
Inspect the headstock wire rope ensuring that the rope is not frayed. If in doubt; replace			
Inspect the wheel arm to ensure its set-up to offer safe carrying of the machine and level cutting at the desired cutting height			
Inspect to see all pins are in position and secured with accompanying linch pin			
Inspect to see all warning decals are present, legible and clean			
Inspect PTO shaft and cone guards for integrity and condition			
Inspect to see all protection chains are present			
Inspect to see all fixed guarding protection is present			
Inspect the underside of the gearbox for damage and ingressed debris			
Inspect blade/chain condition against the operator's manual guidance			
Inspect that the correct blades/chains are fitted to the rotor against the operator's manual			
Inspect blade/chain carrier anti-scalp dish condition against the operator's manual guidance			
Mechanical Checks		Comments	OK
Ensure the oil gearbox quantity is to the required. Consult the maintenance schedule to see whether an oil change is scheduled			
Ensure the gearbox breather is present and free from dirt			
Check the gearbox mounting fasteners are tight to the correct torque setting given in the operator's instruction manual			
Randomly test for loose nuts and bolts. Tighten to manual settings			
Grease all grease points in accordance with the operator's manual			
Inspect the skids for condition and tightness of its fasteners			
Check that the input PTO shaft is correctly seated at both the tractor and machine end			
Ensure the PTO retaining chain is fitted stopping guard rotation			
Inspect each of the PTO bearing wear rings for wear			
Taper pin between input shaft and machine is torqued to 230Nm (170 ft/lbs)			

Check machine tyre pressures against the operator's manual		
Check tractor tyre condition and integrity		
Check wheel nut tightness against operator's instruction manual		
Check wheel bearings for play and movement		
Check wheel arm bushes for play and movement		
Tractor spec meets spec requirement of the machine (PTO rpm/HP)		
Inspect blade/chain bolts for condition and tightness against operator's manual torque values		
Ensure that the blades/chains are free-swinging		

Running Checks	Comments	OK
Once all visual and mechanical checks have been made, follow the running checks below		
View the headstock to ensure that its floating in work		
Fully raise and lower the machine, checking for pinch points on the chassis		
Run the machine to operating speed to check for vibration. If vibration is present check the "Troubleshooting" section in the operator's manual		
Check for excess noise and heat build-up in components		

Other comments:

*Disclaimer: All guidance and maintenance advise to be carried out on the machine as written in this inspection record is deemed on the provision that the operator/maintenance operative has fully read and understood the specific operators manual for the given model of machine and follows the guidance and safety precautions described within it.*

*Spearhead claims no responsibility to any machine and/or physical harm caused by anything other than the practice guidelines stated in its specific machine model operators manual.*

Spearhead Machinery Ltd  
Station Road, Salford Priors, Evesham, Worcestershire, WR11 8SW, England  
Tel: +44 (0)1789 491860

## 5.10 Machine Storage

Follow the following sections for guidance to correctly storing Multicut machines out of working use and preparing back into correct working condition.

### 5.10.1 Preparing The Machine For Storage

Following seasonal use it is important to prepare the machine for storage, thinking of the preservation of parts condition and ease of reintroduction when bringing the machine back into work after periods of no use.

Follow the following points:

5.10.1.1 Thoroughly wash the machine removing all traces of grass and dirt.

Great care should be taken when using pressure washers. **Do not** hold the pressure washer lance close to the paintwork and items containing seals as this can cause damage and discolouration.

Spearhead does not recommend using steam cleaners.

5.10.1.2 Remove and store the input PTO shaft.

5.10.1.3 Carefully fold the headstock over towards the centre of the machine.

5.10.1.4 Inflate tyre to the correct pressure as stated in Section 5.6.1.

5.10.1.5 Grease all grease points following the guidance given in Section 5.2.3 and 5.2.4.

5.10.1.6 Tighten all fasteners and pins to the recommended torque.

5.10.1.7 Use touch up paint available from Spearhead where necessary to preserve the appearance of the machine.

5.10.1.8 Ideally store the machine in the dry indoors, on a firm surface or stands, away from the elements. This will greatly preserve the machines physical appearance and condition.

It is also best practice to inspect the machine for worn/damaged items which will be required to be replaced before entering work again in the new season. Consult the maintenance schedule for the machine (Section 5.9) as well as other specific maintenance task sections to see what could be required to be done to the machine.

Ordering replacement parts at the beginning of this period with plenty of time will potentially reduce the delays of reintroduction into work with out of stock items. Many other local operators will be carrying out the same procedure at the same time.



**Figure 5.44 – Prepare For Storage**

Where parts are broken, damaged and deemed not fit for use; replace with genuine Spearhead parts using the online Interactive Parts facility at

<https://my.spearheadmachinery.com/parts/public-interactive-parts-database/>

You will require the machine serial number. Assistance to its location can be found in Section 1.3. Spearhead Multicut rotary mowers are designed to withstand the most rigorous conditions and with a little care and attention will give many years of trouble-free service. So as not to invalidate the warranty and to avoid problem, use only genuine Spearhead parts and make sure the machine is not driven at a speed in excess of 540 rpm on the PTO.



## 5.10.2 Returning The Machine Back To Work

Returning the machine back to work, in most cases, is similar to preparing the machine for storage shown in Section 5.10.1. If the procedure shown in that section is adhered to, a lot of the preparation work will have already been done to quickly reintroduce the machine back into work condition.

Follow the following points:

- 5.10.2.1 Depending on the period of the machine being unused and whether the machine has been stored outside, the machine may require cleaning.

Great care should be taken when using pressure washers. **Do not** hold the pressure washer lance close to the paintwork and items containing seals as this can cause damage and discolouration.

Spearhead does not recommend using steam cleaners.

- 5.10.2.2 Fit the input PTO shaft following the guidance given in Section 4.4.1 and torque the taper pin to 230Nm (170 ft/lbs).
- 5.10.2.3 Inflate tyre to the correct pressure as stated in Section 5.6.1.
- 5.10.2.4 If not carried out before storage, grease all grease points following the guidance given in Section 5.2.
- 5.10.2.5 If not carried out before storage, tighten all fasteners and pins to the recommended torque.
- 5.10.2.6 Carry out a full machine inspection, using the Machine Inspection Record guide sheet found in Section 5.9.

Where parts are broken, damaged and deemed not fit for use; replace with genuine Spearhead parts using the online Interactive Parts facility at:

<https://my.spearheadmachinery.com/parts/public-interactive-parts-database/>

You will require the machine serial number. Assistance to its location can be found in Section 1.3

Spearhead Multicut rotary mowers are designed to withstand the most rigorous conditions and with a little care and attention will give many years of trouble-free service. So as not to invalidate the warranty and to avoid problem, use only genuine Spearhead parts and make sure the machine is not driven at a speed in excess of 540 rpm on the PTO.

## 6 Troubleshooting

	Symptom	Possible Cause	Remedy
6.1	Irregular cut	a) Worn, bent or broken blades/chains	Replace ALL blades/chains immediately. <ul style="list-style-type: none"> <li>• Raise cutting height to avoid striking objects</li> <li>• Remove/avoid obstacles such as rocks</li> <li>• Check rotor speed</li> <li>• Ensure steady initial starting of the machine</li> </ul>
		b) PTO input speed too slow	Check PTO input speed and increase to maximum indicated; see Section 2.5.1
		c) Machine is not setup to cut correctly	Set up the pitch of the machine correctly front to rear. See Section 4.5.1
		d) Clogged material due to excessive ground speed	Reduce tractor speed over ground and check correct PTO input speed
6.2	Machine noise	a) Loose bolts	Check and tighten to the correct torque. See Section 5.8
		b) Damage to a fabrication or cracks	Repair fabrication in specialised, approved workshop or replace component with genuine part
		c) Vibration	See "Vibration" symptom heading below
6.3	Gearbox noise	a) Lack of oil	Fill to level mark on gearbox
		b) Worn gears	Replace gears with genuine Spearhead part
		c) Worn bearings	Replace bearings with genuine Spearhead part
6.4	Vibration!	a) Lost/broken blades/chains (see 6.5)	Replace all blades/chains on that rotor
		b) Bent gearbox rotor	Replace gearbox shaft and seals
		c) Worn gearbox bearings	Replace bearings and seals
		d) PTO speed too high	Reduce PTO speed to the correct operating speed
6.5	Broken/damaged blades/chains	a) Blades/chains struck object	Raise cutting height to avoid striking objects again Remove/avoid obstacles such as rocks
		b) PTO going too fast	Reduce PTO speed to the correct operating speed
		c) Blades/chains sped up too quickly	Ensure a steady engagement into driving the PTO with a low tractor engine speed
		d) Excess play in blade/chain mounting	Worn blade/chain bushes. Bolts loose, tighten to torque setting as stated in Section 5.8
6.6	Damaged/worn blade/chain carrier	a) Blade/chain carrier struck object	Raise cutting height to avoid striking objects again Remove/avoid obstacles such as rocks
		b) PTO going too fast	Reduce PTO speed to the correct operating speed
		c) Blade/chain carrier sped up too quickly	Ensure a steady engagement into driving the PTO with a low tractor engine speed
		d) Excess play in blade/chain mounting	Worn blade/chain bushes. Bolts loose, tighten to torque setting as stated in Section 5.8
		e) Failure to keep tight centre retaining nut	Tighten nut and secure with split pin
6.7	Damaged gearbox	a) PTO shaft telescopic guard bottoming out	Shorten the telescopic following the guidance in Section 3.3.3
		b) Engaged PTO drive with too much speed	Ensure a steady engagement into driving the PTO with a low tractor engine speed
		c) Lack of grease on sliding tubes of drive shaft	Remove and split the PTO shaft following guidance in Section 5.2.2 and grease the two halves
6.8	Damaged connecting shafts	a) Blades/chains sped up too quickly	Ensure a steady engagement into driving the PTO with a low tractor engine speed
		b) Blade/chain carrier struck object	Raise cutting height to avoid striking objects again Remove/avoid obstacles such as rocks

<b>6.9</b>	<b>Gearbox overheating</b>	a) Incorrect oil level	Fill to level mark on gearbox
		b) Incorrect grade of oil	Drain existing oil and refill using the operators manual as a guide to the correct grade
		c) Incorrect operating speed	Operate the PTO speed at the correct speed as stated on the decal on the front of the machine
		d) Machine overloaded	Reduce tractor/machine forward speed
		e) Build-up of material around the gearbox	Stop the machine. Being careful of heat, clear the material around the gearbox
<b>6.10</b>	<b>Damage to PTO shaft</b>	f) PTO shaft telescopic guard bottoming out	Shorten the telescopic following the guidance in Section 3.3.3
		g) Engaged PTO drive with too much speed	Ensure a steady engagement into driving the PTO with a low tractor engine speed
		h) Not enough overlap	Purchase another input shaft and cut to the correct length (to give sufficient overlap) following the guidance given in Section 3.3.3
		i) Lack of grease	Grease various locations on the shaft following the guidance given in Section 5.2.2
		j) Build-up of material under drive shaft	Stop the machine. Being careful of heat, clear the material under the drive shaft
<b>6.11</b>	<b>Gearbox oil leak</b>	a) Damaged output shaft oil seal	Inspect the gearbox seal protector for foreign material (e.g. wire). Remove and replace oil seal
		b) Faulty breather	Remove the breather and clean or replace
		c) Damaged gasket	Remove the covering plate/housing and replace gasket
		d) Incorrect oil level	Fill to level mark on gearbox
<b>6.12</b>	<b>Metal fatigue on fabrication</b>	a) Too fast working/transportation speed	Slow down! See Section 4.8 on the guidance to correctly driving the machine correctly in work and during transportation
		b) Used in a poor manner/condition	See Section 4.8 on the guidance to correctly driving the machine correctly in work and during transportation. See Section 5 on the guidance to correctly maintaining the machine
		c) Machine not floating correctly	Re-adjust the position of the top link between the tractor and machine in order to create slack in the wire ropes
<b>6.13</b>	<b>Excessive skid wear</b>	a) Running the machine too low	Adjust the machine to the correct height following the guidance in Section 4.6

## 7 Spare Parts

### 7.1 How To Obtain The Correct Spare Part Numbers

For correct part numbers; use the Spearhead interactive online parts books. These are available at <https://my.spearheadmachinery.com/parts/public-interactive-parts-database/>. You will need to enter the machine serial number; see Figure 1.4.

#### 7.1.1.1 Enter the serial number.

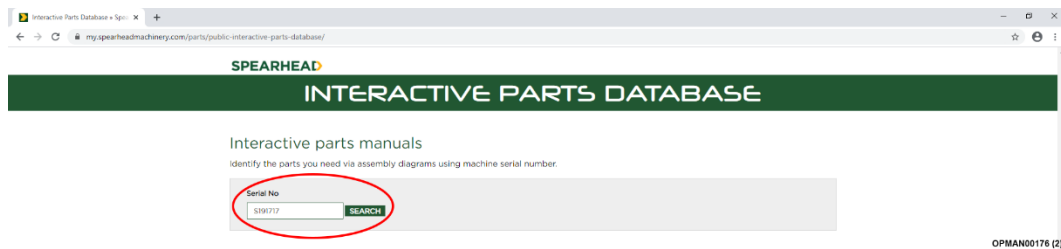

**Figure 7.1 – Type In Serial Number**

#### 7.1.1.2 After entering the serial number a specification for the machine will appear. Click on the serial number; see Figure 7.2.

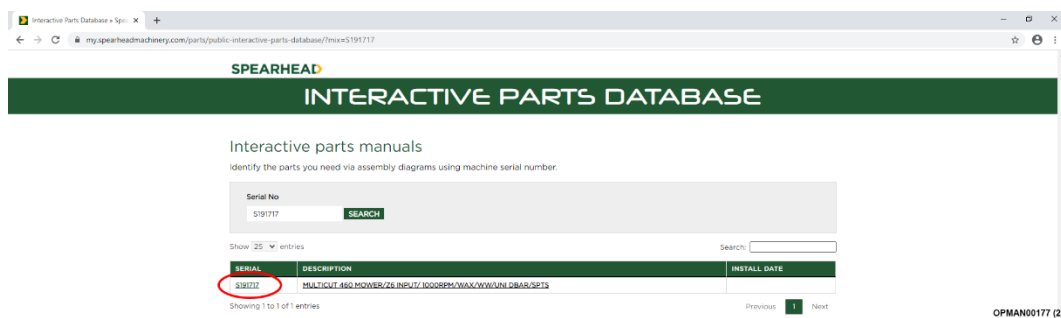

**Figure 7.2 – Click On Serial Number**

#### 7.1.1.3 After clicking on the serial number a full parts breakdown, specific to the machine serial number will appear showing the various parts and assemblies of the machine. Click on the specific assembly picture required; see Figure 7.3.

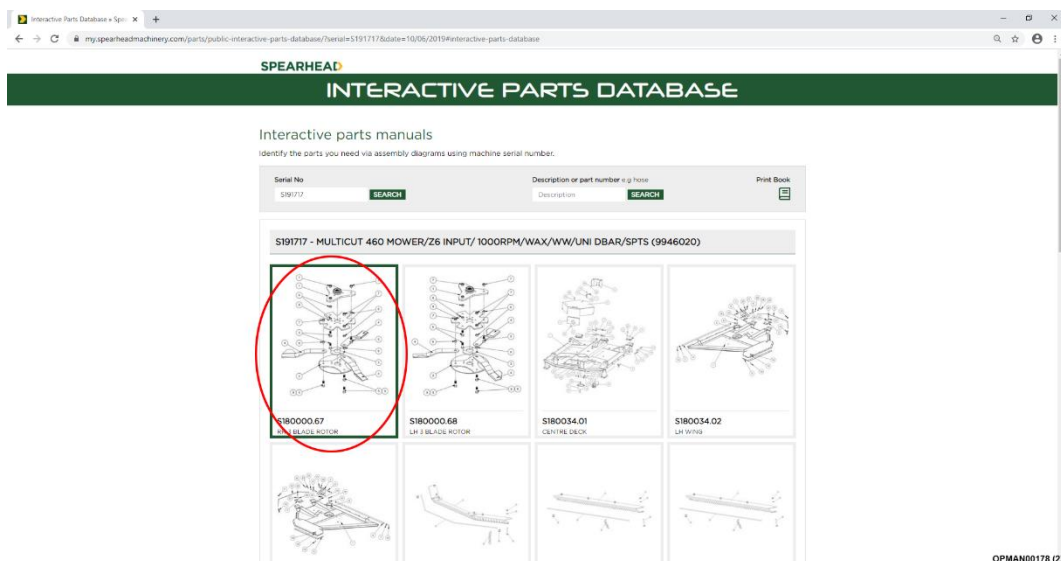

**Figure 7.3 – Click On Assembly**

- 7.1.1.4 You will finally be presented with a full exploded parts breakdown for that particular assembly, giving part numbers and the quantities required; see Figure 7.4.

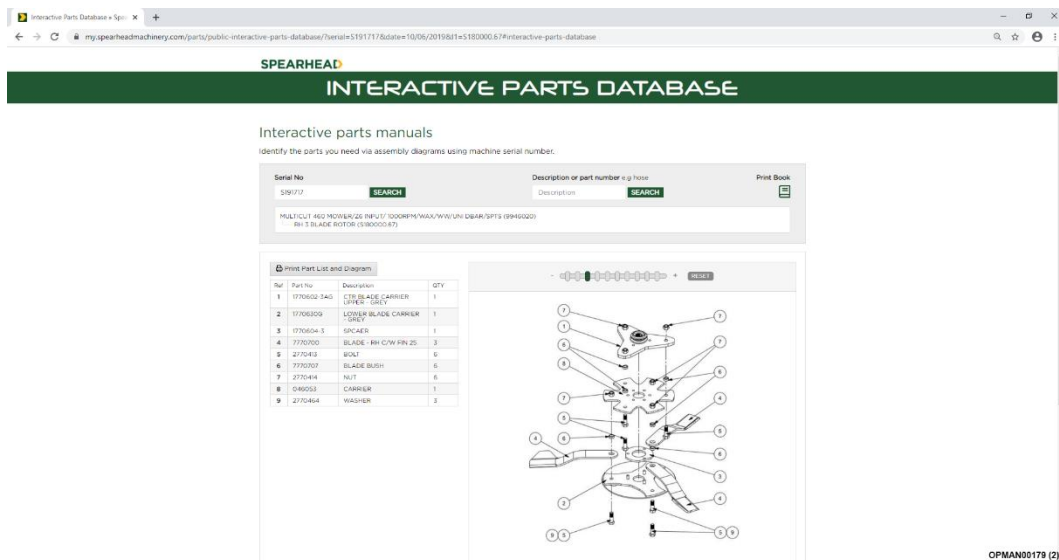

Figure 7.4 – Exploded Parts Breakdown With Bill Of Materials

## 7.2 Spare Parts Ordering

It is important to note that when it comes to ordering replacement parts, that this can **only** be carried out through a Spearhead dealer. **Spearhead does not accept direct customer parts orders over email, fax or telephone.**

For guidance on finding your local Spearhead dealer; see Section 7.3.

## 7.3 Dealer Network

Spearhead has an extensive dealer network which can offer genuine replacement parts.

In order to make it easier to find your local Spearhead dealer, the Spearhead website has a Dealer Locator facility.

<http://www.spearheadmachinery.com/dealer-locator/>

To find your local Spearhead dealer enter your location or postcode into the “Your location” box and then press “Search”; see Figure 7.5.

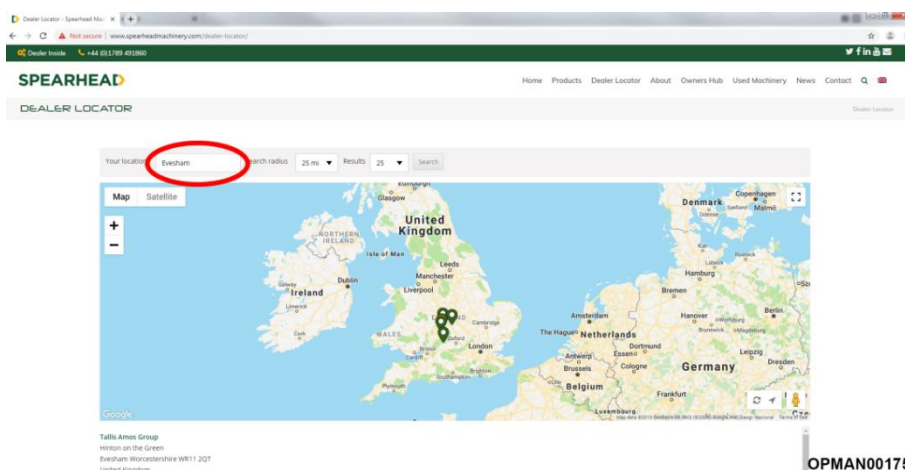

Figure 7.5 – Dealer Locator

# Notes

# Notes