

**Spearhead Machinery
Parts Manual For**

HD ROTARY HEAD

1.50m cut width

Heavy-duty vegetation control hydraulic drive rotary cutting
attachment

8999150EN v1

IMPORTANT

NOTE HERE THE SERIAL NUMBER OF YOUR MACHINE AND ALWAYS QUOTE IT IN ANY COMMUNICATION WITH US OR YOUR DEALER. THIS IS PARTICULARLY IMPORTANT WHEN ORDERING SPARES. REMEMBER TO INCLUDE ALL NUMBERS AND LETTERS.

MACHINE SERIAL NUMBERS _____

THE INFORMATION GIVEN THROUGHOUT THIS MANUAL IS CORRECT AT THE TIME OF PUBLICATION. HOWEVER, IN THE COURSE OF CONSTANT DEVELOPMENT OF SPEARHEAD MACHINES, CHANGES IN SPECIFICATION ARE INEVITABLE. SHOULD YOU FIND THE INFORMATION GIVEN IN THIS BOOK TO BE AT VARIANCE WITH THE MACHINE IN YOUR POSSESSION, YOU ARE ADVISED TO CONTACT THE SPEARHEAD SERVICE DEPARTMENT WHERE UP-TO-DATE INFORMATION WILL BE PROVIDED.

THE MANUAL CAN CONTAIN STANDARD AND OPTIONAL FEATURES AND IS NOT TO BE USED AS A MACHINE SPECIFICATION.

THE MACHINE HAS BEEN TESTED AND IS CONSIDERED SAFE IF CAREFULLY USED. ENSURE YOUR OPERATOR IS PROPERLY TRAINED IN ITS USE AND MAINTENANCE.

IMPORTANT

NOTEZ ICI LES NUMEROS DE SERIE DE VOTRE MACHINE ET MENTIONNEZ LES DANS TOUTE COMMUNICATION AVEC NOS SERVICES OU VOTRE REVENDEUR. CECI EST IMPORTANT POUR LA COMMANDE DE PIECES DETACHEES. PENSEZ A NOTER TOUS LES NUMEROS ET TOUTES LES LETTERS.

NUMEROS DE SERIE DE LA MACHINE _____

LES INFORMATIONS DONNEES DANS CE MANUEL SONT CORRECTES CEPENDANT, DU FAIT DE DEVELOPPEMENT CONSTANT DES MACHINES SPEARHEAD.

CHANGEMENTS DANS LES CARACTERISTIQUES SONT INEVITABLES.

SI VOUS TROUVEZ QUE LES INFORMATIONS DONNEES NE CORRESPONDENT PAS A VOTRE MACHINE VEUILLEZ CONTACTER LE SERVICE DES REPARATIONS OU DES INFORMATIONS PLUS RECENTES VOUS SERONT DONNEES.

CE MANUEL PEUT MONTRER DES CARACTERISTIQUES OPTIONNELLES ET NE PEUT PAS ETRE CONSIDERE COMME SPECIFICATION DE LA MACHINE.

CETTE MACHINE A ETE TESTEE, ET ELLE EST CONSIDEREE COMME FIABLE A CONDITION D'UNE BONNE UTILISATION. ASSUREZ-VOUS QUE VOTRE OPERATEUR EST QUALIFIE EN CE QUI CONCERNE L'UTILISATION DE LA MACHINE AINSI QUE SON ENTRETIEN.

WICHTIG

TRAGEN SIE HIER DIE SERIENNUMMERN IHRER MASCHINE EIN UND GEBEN SIE DIESE IMMER AN, WENN SIE SICH AN UNS ODER IHREN HÄNDLER WENDEN. DAS IST BESONDERS BEI ERSATZTEILBESTELLUNGEN WICHTIG. VERGESSEN SIE NICHT, ALLE ZAHLEN UND BUCHSTABEN ZU NOTIEREN.

SERIENNUMMERN DER MASCHINE _____

DIE ANGABEN IN DIESEM HANDBUCH SIND BEI VERÖFFENTLICHUNG KORREKT. AUFGRUND DER KONSTANTEN WEITERENTWICKLUNG VON SPEARHEAD MASCHINEN SIND JEDOCHÄNDERUGDEN IN DER SPEZIFIKATION UNVERMEIDLICH. WENN DIE INFORMATION IN DIESEM HANDBUCH NICHT MIT IHRER MASCHINE ÜBEREINSTIMMEN, NEHMEN SIE BITTE KONTAKT MIT DER SPEARHEAD KUNDENDIENSTABTEILUNG AUF, DIE IHNEN GERNE DIE AKTUELLEN INFORMATION ZUKOMMEN LÄSST.

DAS HANDBUCH KANN SOWOHL BESCHREIBUNGEN FÜR DIE STANDARD AUSFÜHRUNG ALS AUCH FÜR ZUBEHÖR ENTHALTEN UND IST NICHT ALS MASCHINENSPEZIFIKATION ZU VERWENDET.

DIE MASCHINE IST GETESTET UND BEI SACHGEMÄSSEM BETRIEB ALS SICHER BEFUNDEN WORDEN. SORGEN SIE DAFÜR, DASS IHR BEDIENPERSONAL IN ANWENDUNG UND WARTUNG RICHTIG GESCHULT WIRD.

INDEX

1.5m ROTARY CUTTING HEAD

PAGE ILLUSTRATION NUMBERS SHOWN ARE USED ONLY FOR REFERENCE PURPOSES AND SHOULD NOT BE USED FOR ORDERING SPARE PARTS.

PLEASE ENSURE THE CORRECT PART NUMBER AND DESCRIPTION IS GIVEN WHEN ORDERING SPARE PARTS.

For Machines with Serial Numbers commencing from

SECTION NO	DESCRIPTION
2	CASING ASSEMBLY
3	CHAIN GUARD ASSEMBLY
4	MOTOR & DRIVE ASSEMBLY
5	CUTTING CHAINS ASSEMBLY
6	HYDRAULIC INSTALLATION
7	HYDRAULIC RAM ASSEMBLY

IMPORTANT

THIS MACHINE IS FOR VEGETATION CONTROL AND MUST NOT BE USED FOR ANY OTHER PURPOSE.
IT IS POTENTIALLY HAZARDOUS TO FIT OR USE ANY PARTS OTHER THAN GENUINE SPEARHEAD PARTS.
THE COMPANY DISCLAIMS ALL LIABILITY FOR THE CONSEQUENCES OF SUCH USE WHICH, IN ADDITION, VOIDS THE MACHINE WARRANTY.

CASING ASSEMBLY
1039701 REV: B

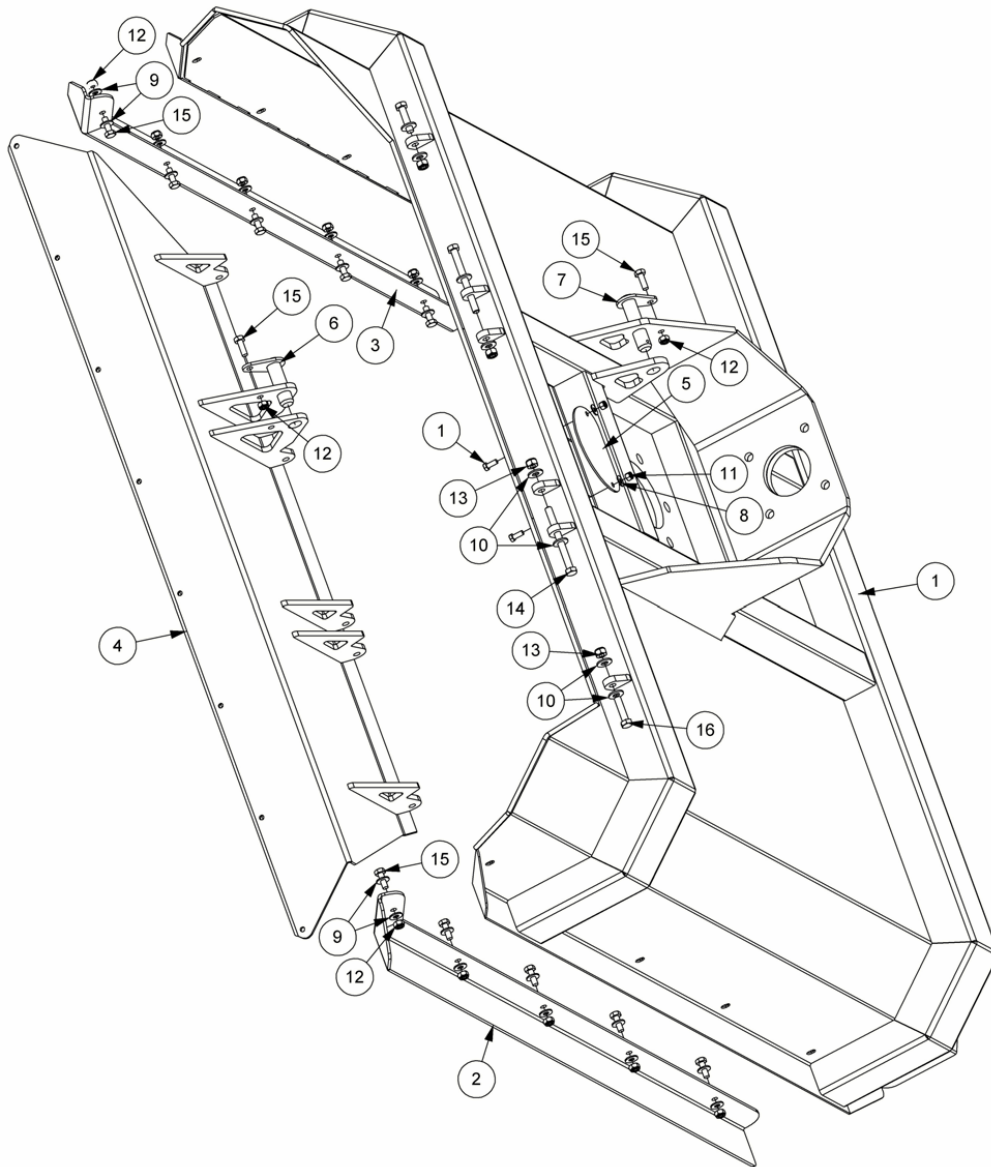

ITEM NO.	PART NUMBER	DESCRIPTION	QTY
1	22279.03	1.5M HD ROTARY HEAD CASING	1
2	22282.01	SKID - L/H	1
3	22282.02	SKID - R/H	1
4	22286.01	FRONT HOOD	1
5	22319.01	ACCESS COVER	1
6	41691.06	PIN	1
7	41693.01	PIN - ANGLE ROD END	1
8	9100104	FLAT WASHER	2
9	9100105	FLAT WASHER	20
10	9100106	FLAT WASHER	8
11	9163004	NYLOC NUT	2
12	9163005	NYLOC NUT	12
13	9163006	NYLOC NUT	4
14	9213266	BOLT	2
15	9313065	SETSCREW	12
16	9313106	SETSCREW	2

CHAIN GUARD ASSEMBLY
1039709 REV: A

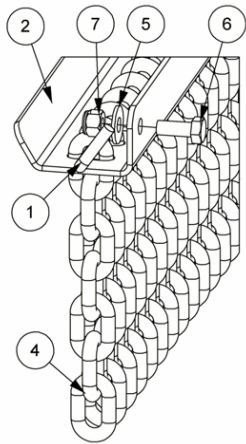
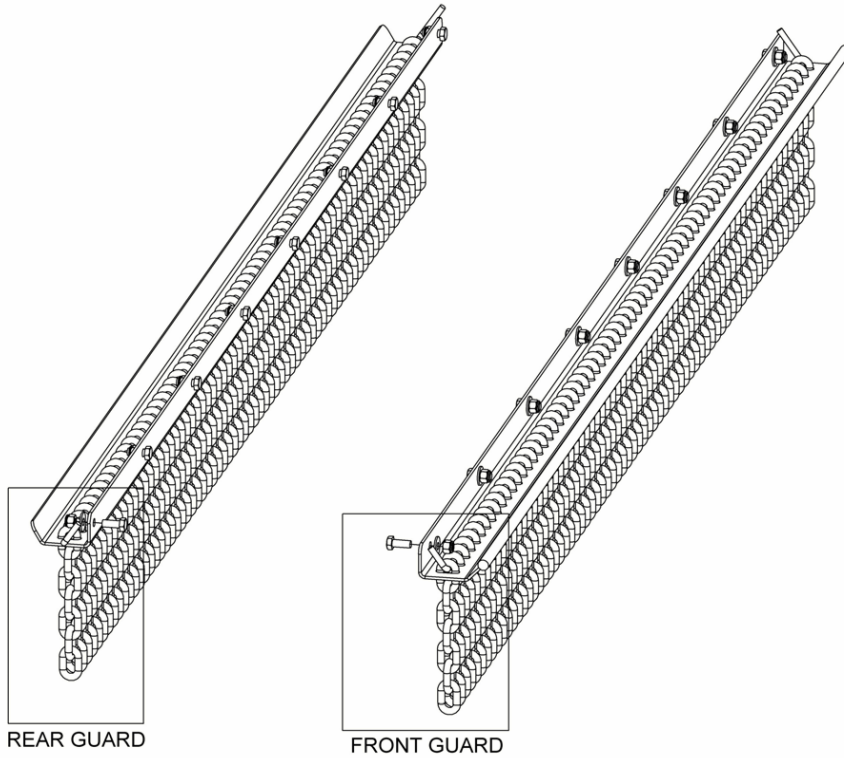

REAR GUARD DETAIL

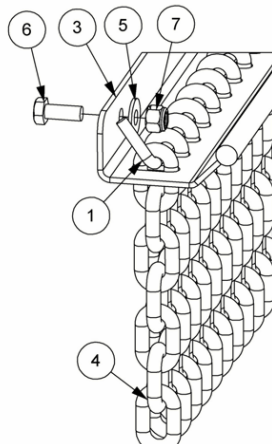

FRONT GUARD DETAIL

ITEM NO.	PART NUMBER	DESCRIPTION	QTY
1	22148.10	CHAIN RETAINING BAR	2
2	22321.01	REAR CHAIN GUARD MOUNTING	1
3	22321.02	FRONT CHAIN GUARD MOUNTING	1
4	46943.21	CHAIN SET (7 LINKS)	136
5	9100104	FLAT WASHER	16
6	9313044	SETSCREW	16
7	9163004	NYLOC NUT	16

MOTOR & DRIVE ASSEMBLY
1039703 REV: A

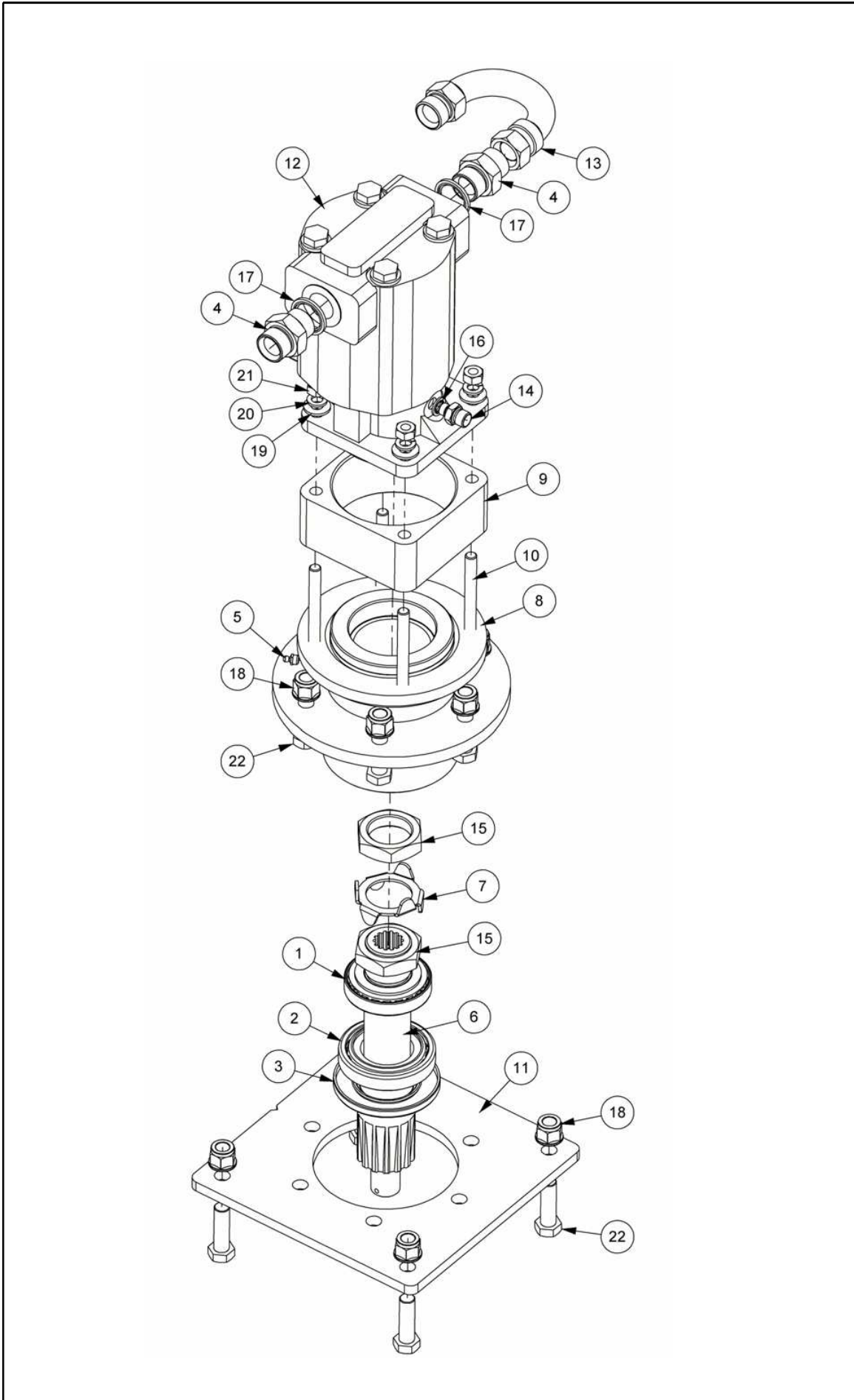

MOTOR & DRIVE ASSEMBLY
1039703 REV: A

ITEM NO.	PART NUMBER	DESCRIPTION	QTY
1	00769938	TAPERED ROLLER BEARING	1
2	00770725	TAPERED ROLLER BEARING	1
3	00770726	ROTARY SEAL	1
4	05.434.01	ADAPTOR	2
5	0901121	GREASE NIPPLE	1
6	22297.01	DRIVE SHAFT	1
7	22310.01	LOCKING WASHER	1
8	22311.01	BEARING HOUSING	1
9	22312.01	MOTOR SPACER	1
10	22313.01	MOTOR MOUNTING STUD	4
11	22314.01	MOUNTING PLATE	1
12	43506.01	HYDRAULIC MOTOR	1
13	46043.01	RIGID PIPE	1
14	8581115	ADAPTOR	1
15	8581422	ADAPTOR BACKNUT	2
16	8650102	BONDED SEAL	1
17	8650108	BONDED SEAL	2
18	9100024	SELF-LOCKING FLANGE NUT	10
19	9100106	FLAT WASHER	4
20	9100206	SPRING WASHER	4
21	9143006	SELF-LOCKING NUT	4
22	9200023	BOLT	10

CUTTING CHAINS ASSEMBLY

1039704 REV: A

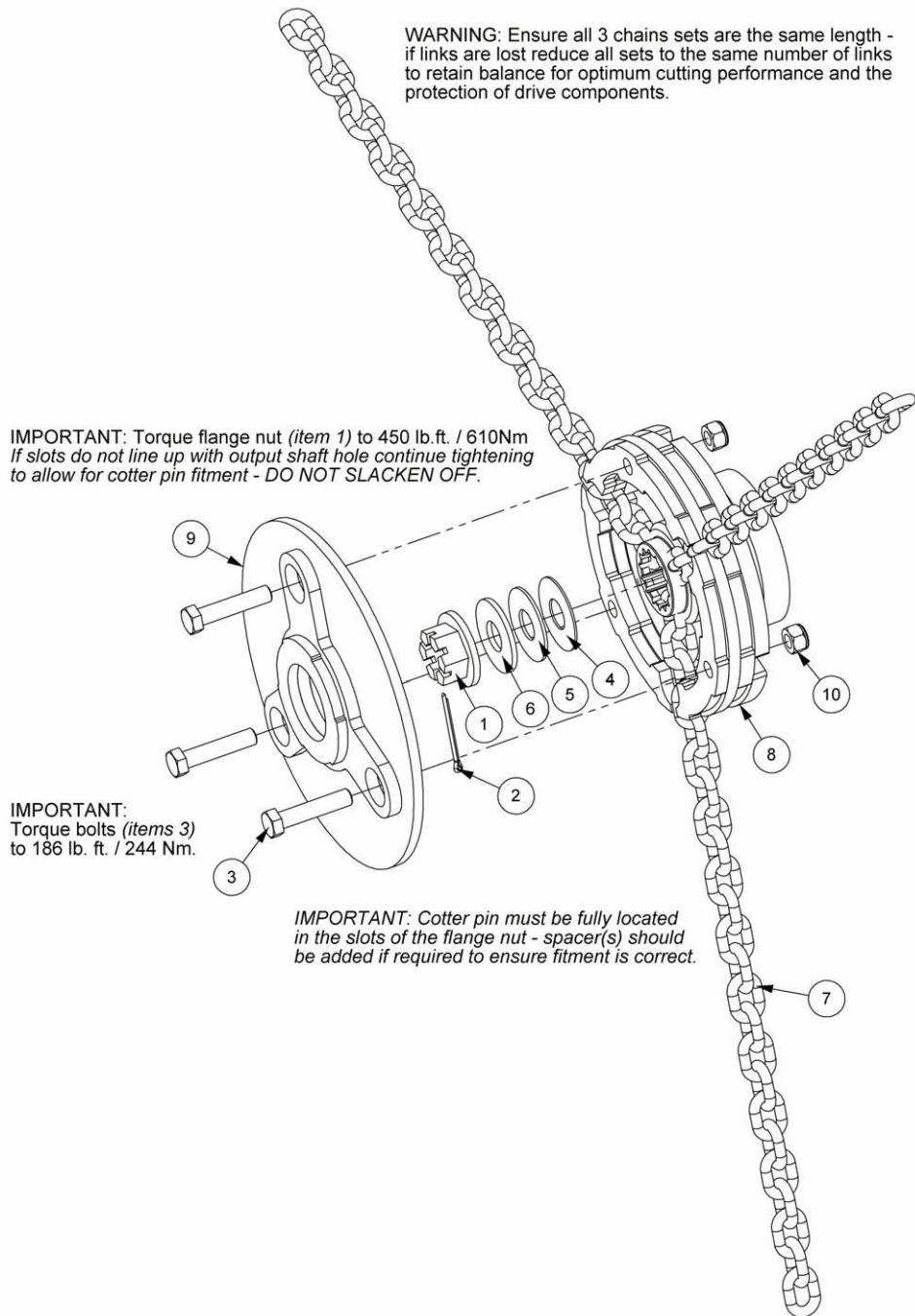

ITEM NO.	PART NUMBER	DESCRIPTION	QTY
1	00771226	FLANGE NUT (SLOTTED)	1
2	0503205	COTTER PIN	1
3	12.714.75	BOLT	3
4	22165.01	BLADE PAN SHIM - 2mm	1
5	22165.02	BLADE PAN SHIM - 3mm	1
6	22165.03	BLADE PAN SHIM - 5mm	1
7	22315.01	CHAINS (SET OF 3)	1
8	22323.01	CHAIN MOUNTING HUB	1
9	22327.01	CHAIN CLAMP	1
10	T7942	NYLOC NUT	3

HYDRAULIC INSTALLATION
1039711 REV: A

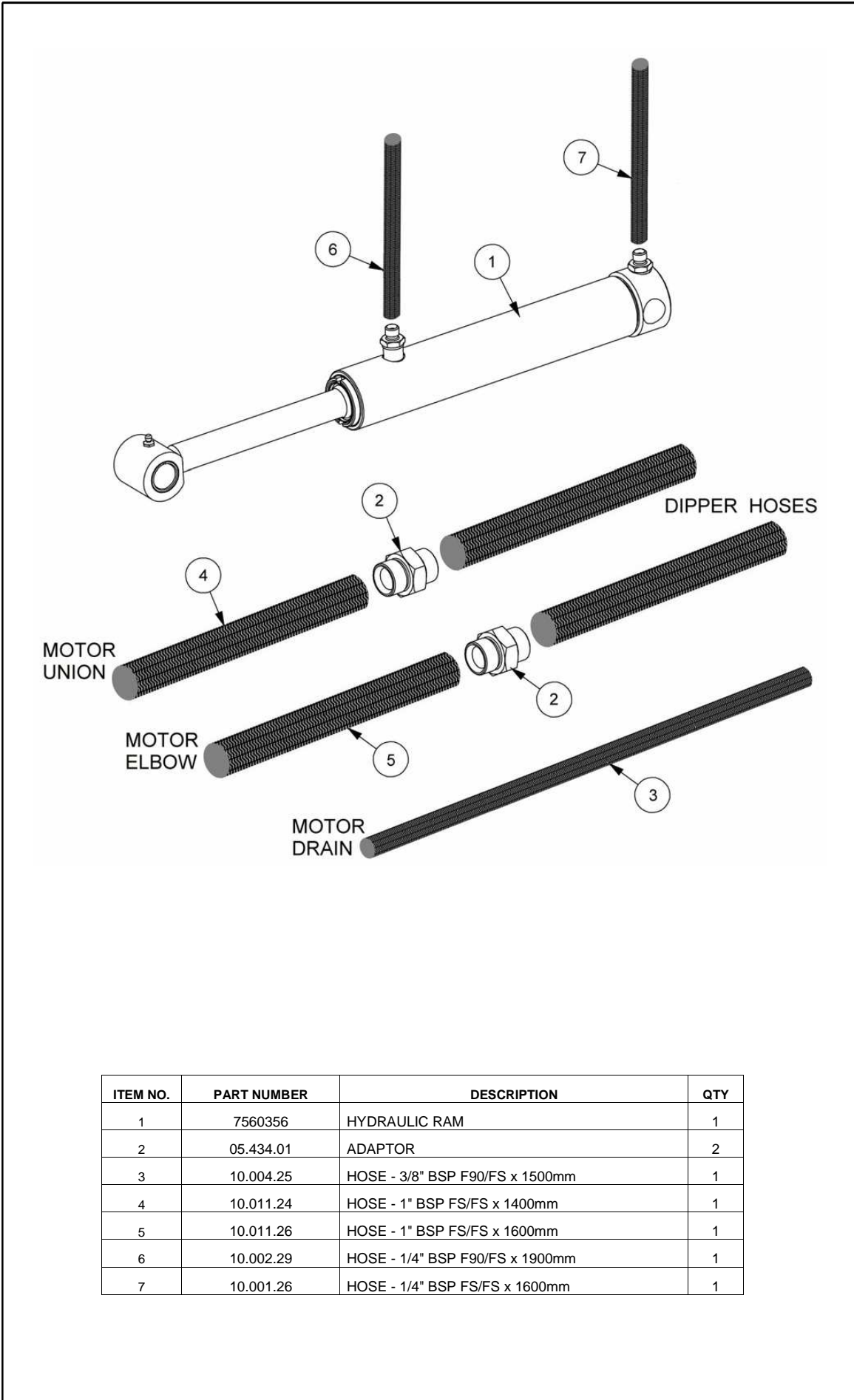

ITEM NO.	PART NUMBER	DESCRIPTION	QTY
1	7560356	HYDRAULIC RAM	1
2	05.434.01	ADAPTOR	2
3	10.004.25	HOSE - 3/8" BSP F90/FS x 1500mm	1
4	10.011.24	HOSE - 1" BSP FS/FS x 1400mm	1
5	10.011.26	HOSE - 1" BSP FS/FS x 1600mm	1
6	10.002.29	HOSE - 1/4" BSP F90/FS x 1900mm	1
7	10.001.26	HOSE - 1/4" BSP FS/FS x 1600mm	1

HYDRAULIC RAM ASSEMBLY 7560356 REV: B

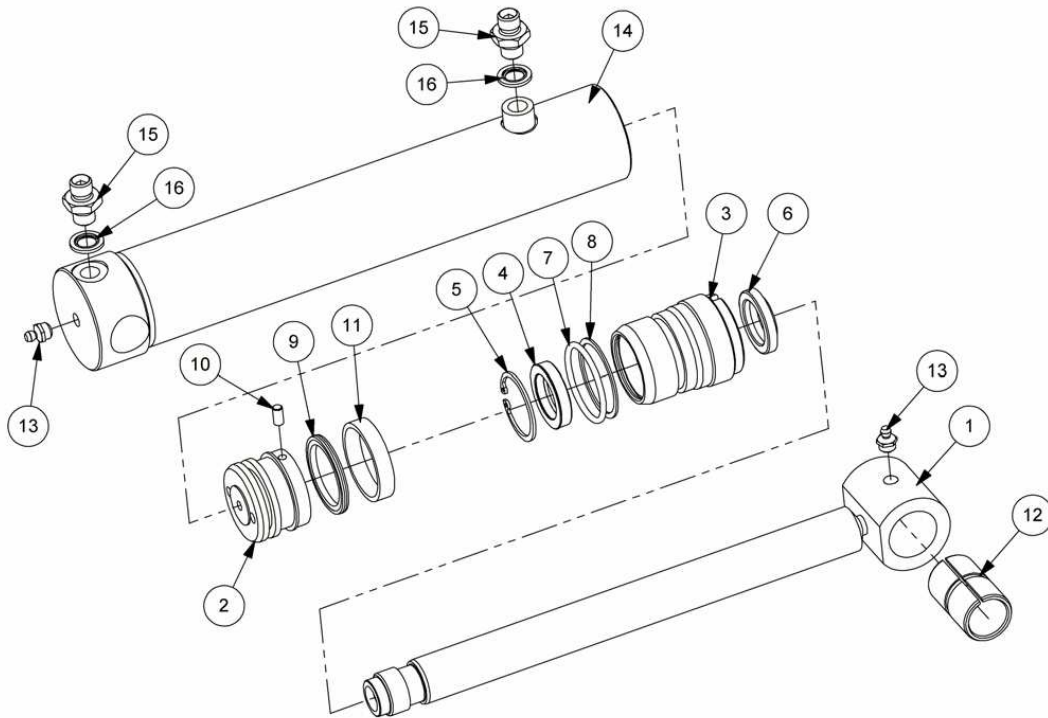

ITEM NO.	PART NUMBER	DESCRIPTION	QTY
1	7195010	PISTON ROD	1
2	7560095	PISTON	1
3	7135291	GLAND HOUSING	1
4	8629148	GLAND SEAL	1
5	0416240	INTERNAL CIRCLIP	1
6	8629149	SCRAPER RING	1
7	8600302	O RING	1
8	8609302	AE RING	1
9	8629187	PISTON SEAL	1
10	9363023	GRUB SCREW	1
11	8629188	GUIDE RING	1
12	7105050	ROD END BUSH	1
13	0901121	GREASE NIPPLE	2
14	7195305	BARREL	1
15	8581169	ADAPTOR	2
16	8650102	BONDED SEAL	2
	8699188	SEAL KIT	0