

# SPEARHEAD

## 1.0m COMPACT FLAIL HEAD

WGC: 7490874SH

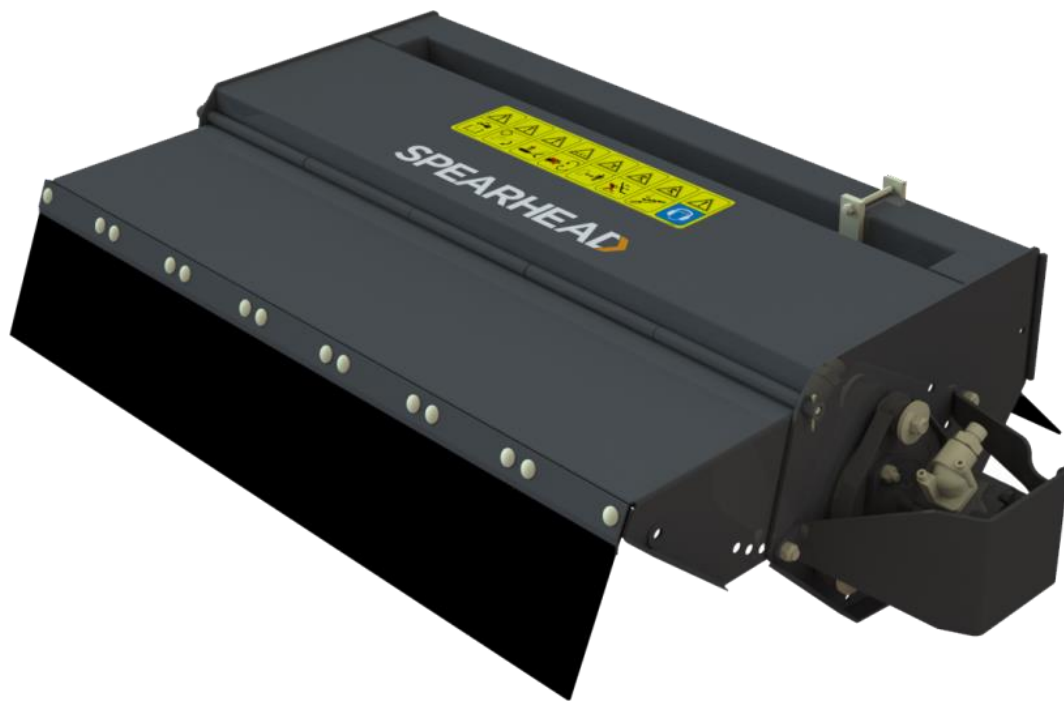

Edition 1.1 – December 2020  
Part No. 8999138

# HANDBOOK

# I.0M COMPACT FLAIL HEAD

## VERIFICATION OF WARRANTY REGISTRATION



### DEALER WARRANTY INFORMATION & REGISTRATION VERIFICATION

It is imperative that the selling dealer registers this machine with Spearhead Machinery Limited before delivery to the end user – failure to do so may affect the validity of the machine warranty.

To register machines go to the Spearhead Machinery Limited web site at [www.spearheadmachinery.com](http://www.spearheadmachinery.com), log onto 'Dealer Inside' and select the 'Machine Registration button' which can be found in the Service Section of the site.

Confirm to the customer that the machine has been registered in the section below.

Should you experience any problems registering a machine in this manner please contact the Spearhead Service Department on 01789 491867.

### Registration Verification

	.....
<b>Dealer Address:</b>	.....
<b>Customer Name:</b>	.....
<b>Date of Warranty Registration:</b>	...../...../..... <b>Dealer Signature:</b> .....

### NOTE TO CUSTOMER / OWNER

*Please ensure that the above section has been completed and signed by the selling dealer to verify that your machine has been registered with Spearhead Machinery Limited.*

**IMPORTANT:** During the initial 'bedding in' period of a new machine it is the customer's responsibility to regularly inspect all nuts, bolts and hose connections for tightness and re-tighten if required. New hydraulic connections occasionally weep small amounts of oil as the seals and joints settle in – where this occurs it can be cured by re-tightening the connection – refer to torque settings chart below. The tasks stated above should be performed on an hourly basis during the first day of work and at least daily thereafter as part of the machines general maintenance procedure.

### CAUTION: DO NOT OVER TORQUE HYDRAULIC FITTINGS AND HOSES

#### TORQUE SETTINGS FOR HYDRAULIC FITTINGS

HYDRAULIC HOSE ENDS		
BSP	Setting	Metric
1/4"	18 Nm	19 mm
3/8"	31 Nm	22 mm
1/2"	49 Nm	27 mm
5/8"	60 Nm	30 mm
3/4"	80 Nm	32 mm
1"	125 Nm	41 mm
1.1/4"	190 Nm	50 mm
1.1/2"	250 Nm	55 mm
2"	420 Nm	70 mm

PORT ADAPTORS WITH BONDED SEALS		
BSP	Setting	Metric
1/4"	34 Nm	19 mm
3/8"	47 Nm	22 mm
1/2"	102 Nm	27 mm
5/8"	122 Nm	30 mm
3/4"	149 Nm	32 mm
1"	203 Nm	41 mm
1.1/4"	305 Nm	50 mm
1.1/2"	305 Nm	55 mm
2"	400 Nm	70 mm

# I.0M COMPACT FLAIL HEAD

# 1.0M COMPACT FLAIL HEAD

# SPEARHEAD

Station Road, Salford Priors, Evesham, Worcestershire, WR11 8SW

*For Safety and Performance...*

## ALWAYS READ THE BOOK FIRST

### - NOISE STATEMENT -

The equivalent daily personal noise exposure from this machine measured at the operators' ear is within the range 78 – 85 dB, these figures apply to a normal distribution of use where the noise fluctuates between zero and maximum. The figures assume that the machine is fitted to a tractor with a 'quiet' cab with the windows closed in a generally open environment. We recommend that the windows are kept closed. With the cab rear window open the equivalent daily personal noise exposure will increase to a figure within the range 82 – 88 dB. At an equivalent daily noise exposure level of 85 – 90 dB ear protection is recommended and must always be used if any window is left open.



Operating, servicing and maintaining this equipment can expose you to chemicals including gasoline, diesel fuel, lubricants, petroleum products, engine exhaust, carbon monoxide, and phthalates, which are known to the State of California to cause cancer and birth defects or other reproductive harm. To minimize exposure, avoid breathing exhaust, do not idle the engine except as necessary, service your vehicle in a well-ventilated area and wear gloves or wash your hands frequently when servicing your vehicle. Battery posts, terminals and related accessories contain lead and lead compounds, chemicals known to the state of California to cause cancer, birth defects or other reproductive harm.

For more information go to [www.P65Warnings.ca.gov](http://www.P65Warnings.ca.gov). This website, operated by California's Office of Environmental Health Hazard Assessment, provides information about these chemicals and how individuals may be exposed to them.

# I.0M COMPACT FLAIL HEAD

# I.OM COMPACT FLAIL HEAD

## CONTENTS

---

<b>Operator Section</b>	<b>Page No.</b>
Machine Registration	2
Noise Statement & P65 Warning	4
Contents	6
Safety Warnings	8
Safety Information	10
Safety & Information Decals	14
Pre-Operational Checks	15
Operation	16
Flailhead Arrangement – Grass & Verge Mowing	17
Flailhead Arrangement – Hedge Cutting	21
Hedge Cutting Procedure	23
Maintenance	24



# I.OM COMPACT FLAIL HEAD

Read this manual before fitting or operating the machine or accessory. Whenever any doubt exists contact your local dealer or the Spearhead Service Department for assistance.

**Only use 'Genuine Spearhead Parts' on Spearhead machinery and equipment.**

DEFINITIONS: *The following definitions apply throughout this manual;*

## **⚠ DANGER**

**DANGER:** Alerts to a hazardous situation which will result in death or serious injury if not observed carefully.

## **⚠ WARNING**

**WARNING:** Alerts to a hazardous situation which could result in death or serious injury if not observed carefully.

## **⚠ CAUTION**

**CAUTION:** Alerts to a hazardous situation which could result in damage to the machine and/or equipment if not observed carefully.

## **NOTICE**

**NOTICE:** Specific or general information considered important or useful to emphasise.

**LEFT HAND (LH) & RIGHT HAND (RH):** *These terms are applicable to the machine when fitted to the tractor and viewed from the rear; these terms also apply to tractor references.*

### SERIAL PLATE

*All machines are equipped with a serial number plate containing important information relating to the machine including a unique serial number used for identification purposes.*

*Note: Images in this manual are provided for instruction and informational purposes only and may not show components in their entirety. In certain instances images may appear different to the actual machine; where this occurs the general procedure will be basically the same. E&OE.*

## MACHINE & DEALER INFORMATION

Record the serial number of your machine on this page and always quote it when ordering parts. Whenever information concerning the machine is requested remember to also state the make and model of tractor to which the machine is fitted.

Machine Serial Number:

Installation Date:

Machine Model Details:

Dealer Name & Branch:

Dealer Address:

Dealer Telephone No:

Dealer Email Address:



# I.0M COMPACT FLAIL HEAD

# I.0M COMPACT FLAIL HEAD

## SAFETY INFORMATION

---



This machine has the potential to be extremely dangerous, in the wrong hands it can kill or maim. It is therefore imperative that both owner, and operator of this machine, read and understand the following section to ensure that they are fully aware of the dangers that do, or may exist, and their responsibilities surrounding the use and operation of the machine.

The operator of this machine is responsible not only for their own safety but equally for the safety of others who may come into the close proximity of the machine, as the owner you are responsible for both.

When the machine is not in use the cutting head should be lowered to rest on the ground. In the event of a fault being detected with the machine's operation it should be stopped immediately and not used again until the fault has been corrected by a qualified technician.

### **POTENTIAL SIGNIFICANT DANGERS ASSOCIATED WITH THE USE OF THIS MACHINE:**

- ▲ *Being hit by debris thrown by rotating components.*
- ▲ *Being hit by machine parts ejected through damage during use.*
- ▲ *Being caught on a rotating power take-off (PTO) shaft.*
- ▲ *Being caught in other moving parts i.e.: belts, pulleys and cutting heads.*
- ▲ *Electrocution from Overhead Power Lines (by contact with or 'flashover' from).*
- ▲ *Being hit by cutting heads or machine arms as they move.*
- ▲ *Becoming trapped between tractor and machine when hitching or unhitching.*
- ▲ *Tractor overbalancing when machine arm is extended.*
- ▲ *Injection of high-pressure oil from hydraulic hoses or couplings.*
- ▲ *Machine overbalancing when freestanding (out of use).*

# 1.0M COMPACT FLAIL HEAD

- ▲ *Road traffic accidents due to collision or debris on the road.*
- ▲ *Burn risk from hot components.*

## **BEFORE USING THIS MACHINE YOU MUST:**

- ▲ *Ensure you read all sections of the operator handbook.*
- ▲ *Ensure the operator is, or has been, properly trained to use the machine.*
- ▲ *Ensure the operator has been issued with and reads the operator handbook.*
- ▲ *Ensure the operator understands and follows the instructions in operator handbook.*
- ▲ *Ensure the tractor front, rear and side is fitted with metal mesh or polycarbonate guards of suitable size and strength to protect the operator against thrown debris or parts.*
- ▲ *Ensure tractor guards are fitted correctly, are undamaged and kept properly maintained.*
- ▲ *Ensure that all machine guards are in position, are undamaged, and are kept maintained in accordance with the manufacturer's recommendations.*
- ▲ *Ensure flails and their fixings are of a type recommended by the manufacturer, are securely attached and that none are missing or damaged.*
- ▲ *Ensure hydraulic pipes are carefully and correctly routed to avoid damage by chaffing, stretching or pinching and that they are held in place with the correct fittings.*
- ▲ *Always follow the manufacturer's instructions for attachment and removal of the machine from the tractor.*
- ▲ *Check that the machine fittings and couplings are in good condition.*
- ▲ *Ensure the tractor meets the minimum weight recommendations of the machine's manufacturer and that ballast is used as necessary.*
- ▲ *Always inspect the work area thoroughly before starting to note obstacles and remove wire, bottles, cans and other debris.*
- ▲ *Use clear suitably sized warning signs to alert others to the nature of the machine working within that area. Signs should be placed at both ends of the work site. (It is recommended that signs used are of a size and type specified by the Department of Transport and positioned in accordance with their, and the Local Highways Authority, guidelines).*
- ▲ *Ensure the operator is protected from noise. Ear defenders should be worn and tractor cab doors and windows must be kept closed. Machine controls should be routed through proprietary openings in the cab to enable all windows to be shut fully.*
- ▲ *Always work at a safe speed taking account of the conditions i.e.: terrain, highway proximity and obstacles around and above the machine. Extra special attention should be applied to Overhead Power Lines. Some of our machines are capable of reach in excess of 8 metres (26 feet) this means they have the potential to well exceed, by possibly 3 metres (9' 9"), the lowest legal minimum height of 5.2 metres from the ground for 11,000 and 33,000 volt power lines. It cannot be stressed enough the dangers that surround this capability, it is therefore vital that the operator is fully aware of the maximum height and reach of the machine, and that they are fully conversant with all aspects regarding the safe minimum distances that apply when*

# I.0M COMPACT FLAIL HEAD

*working with machines in close proximity to Power Lines. (Further information on this subject can be obtained from the Health & Safety Executive or your Local Power Company).*

- ▲ *Always disengage the machine, kill the tractor engine, remove and pocket the key before dismantling for any reason.*
- ▲ *Always clear up all debris left at the work area, it may cause hazard to others.*
- ▲ *Always ensure when you remove your machine from the tractor that it is left in a safe and stable position using the stands and props provided and secured if necessary.*

## **WHEN NOT TO USE THIS MACHINE:**

- ▲ *Never attempt to use this machine if you have not been trained to do so.*
- ▲ *Never use a machine until you have read and understood the operator handbook, are familiar with it, and practiced the controls.*
- ▲ *Never use a machine that is poorly maintained.*
- ▲ *Never use a machine if guards are missing or damaged.*
- ▲ *Never use a machine on which the hydraulic system shows signs of wear or damage.*
- ▲ *Never fit, or use, a machine on a tractor that does not meet the manufacturer's minimum specification level.*
- ▲ *Never use a machine fitted to a tractor that does not have suitable front, rear and side(s) cab guarding made of metal mesh or polycarbonate.*
- ▲ *Never use the machine if the tractor cab guarding is damaged, deteriorating or badly fitted.*
- ▲ *Never turn a machine cutting head to an angle that causes debris to be ejected towards the cab.*
- ▲ *Never start or continue to work a machine if people are nearby or approaching - Stop and wait until they are at a safe distance before continuing. WARNING: Some Cutting Heads may continue to 'freewheel' for up to 40 seconds after being stopped.*
- ▲ *Never attempt to use a machine on materials in excess of its capability.*
- ▲ *Never use a machine to perform a task it has not been designed to do.*
- ▲ *Never operate the tractor or machine controls from any position other than from the driving seat, especially whilst hitching or unhitching the machine.*
- ▲ *Never carry out maintenance of a machine or a tractor whilst the engine is running – the engine should be switched off, the key removed and pocketed.*
- ▲ *Never leave a machine unattended in a raised position – it should be lowered to the ground in a safe position on a level firm site.*
- ▲ *Never leave a tractor with the key in or the engine running.*

# I.0M COMPACT FLAIL HEAD

- ▲ *Never carry out maintenance on any part or component of a machine that is raised unless that part or component has been properly substantially braced or supported.*
- ▲ *Never attempt to detect a hydraulic leak with your hand – use a piece of cardboard.*
- ▲ *Never allow children near to, or play on, a tractor or machine under any circumstances.*

## ADDITIONAL SAFETY ADVICE

### Training

Operators need to be competent and fully capable of operating this machine in a safe and efficient way prior to attempting to use it in any public place. We advise therefore that the prospective operator make use of relevant training courses available such as those run by the Agricultural Training Board, Agricultural Colleges, Dealers and Spearhead.

### Working in Public Places

When working in public places such as roadsides, consideration should be paid to others in the vicinity. Stop the machine immediately when pedestrians, cyclists and horse riders etc. pass. Restart only when they are at a distance that causes no risk to their safety.

### Warning Signs

It is advisable that any working area be covered by suitable warning signs and statutory in public places. Signs should be highly visible and well placed in order to give clear advanced warning of the hazard. Contact the Department of Transport or your Local Highways Authority to obtain detailed information on this subject. The latter should be contacted prior to working on the public highway advising them of the time and location of the intended work asking what is required by way of signs and procedure. – *‘Non-authorized placement of road signs may create offences under the Highways Act’.*

### Suggested Warning Signs Required

*“Road works ahead” warning sign with a supplementary “Hedge cutting” plate. “For 1 mile” or appropriate shorter distance may be added to the plate.*

*“Road narrows” warning sign with supplementary “Single file traffic” plate.*

*White on blue “Keep right” (\*) arrow sign on rear of machine.*

*\* Note – this applies to UK Market machines where traffic passes to the right of a machine working in the same direction as the traffic flow. The direction, use and colour of the arrow sign will depend on the country of use and the Local Highway Authorities regulations in the locality.*

### Use of Warning Signs

- ▲ *On two-way roads one set of signs is needed facing traffic in each direction.*
- ▲ *Work should be within 1 mile of the signs.*
- ▲ *Work only when visibility is good and at times of low risk e.g.: NOT during ‘rush-hour’.*
- ▲ *Vehicles should have an amber-flashing beacon.*
- ▲ *Ideally, vehicles should be conspicuously coloured.*
- ▲ *Debris should be removed from the road and path as soon as practicable, and at regular intervals, wearing high visibility clothing and before removing the hazard warning signs.*
- ▲ *Collect all road signs promptly when the job is completed.*

# I.0M COMPACT FLAIL HEAD

Although the information given here covers a wide range of safety subjects, it is impossible to predict every eventuality that can occur under differing circumstances whilst operating this machine. No advice given here can replace 'good common sense' and 'total awareness' at all times, but will go a long way towards the safe use of your Spearhead machine.

## SAFETY & INFORMATION DECALS

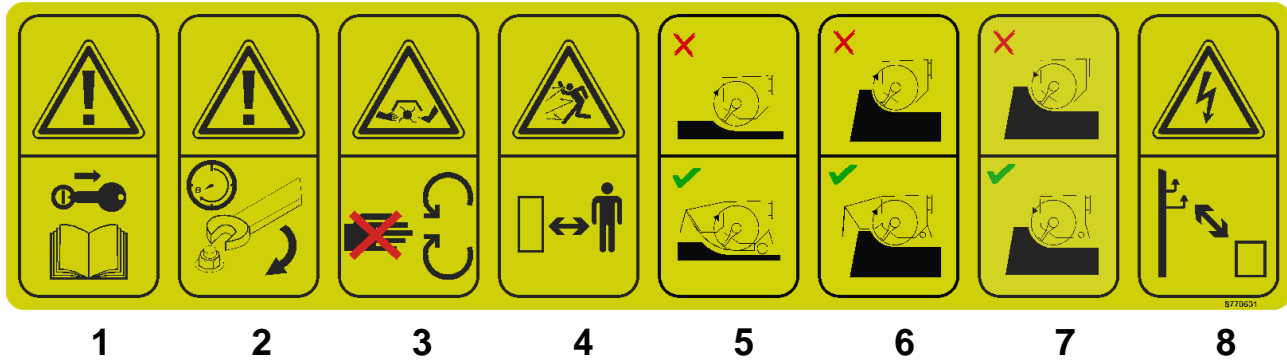

1. Caution! Rotating blades; keep clear of machine, stop machine (wait for rotor to stop), remove starting and read the book first before performing any service or maintenance.
2. Caution! Ensure all nuts and bolts are kept tight at all times.
3. Caution! Thrown objects risk; keep all persons at a safe distance from the working machine at all times.
4. Caution! Grass/Verge Mowing; front hood, front flap, rear roller and rear flap must be fitted and correctly adjusted when using the machine for grass and verge mowing. Flaps must be in good condition.
5. Caution! Hedging (Uphill cutting); front hood, front flap and rear flap must always be fitted and correctly adjusted. Rear roller should be placed into the raised position. Flaps must be in good condition.
6. Caution! Hedging (Uphill cutting); front hood, front flap and rear flap must always be fitted and correctly adjusted. Rear roller should be placed into the raised position. Flaps must be in good condition.
7. Caution! Hedging (Downhill cutting); front hood may be removed, rear flap must be fitted and rear roller placed into the raised position. Flap must be in good condition.
8. Danger! Electrocution and Pylons; keep clear of electric pylons to ensure no chance of electrocution.

# I.OM COMPACT FLAIL HEAD

## PRE-OPERATIONAL CHECKS

---

Check all bolts are tight and that the torque figures are correct for the specific locations indicated below:

### IMPORTANT

On the first day of use with a new flailhead, nuts should be checked for tightness every hour and retightened if required. Thereafter they should be checked on a daily basis prior to use of the machine.

Torque nuts to the settings stated above.

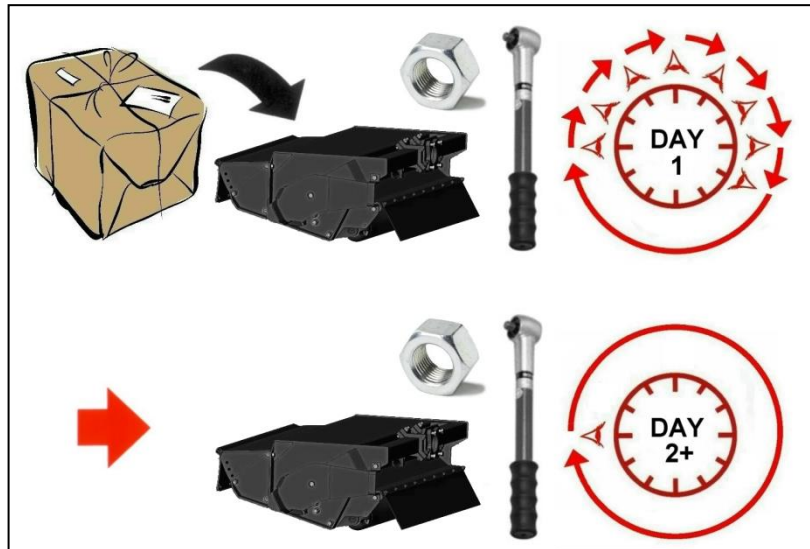

Always inspect the rotor assembly for damaged or missing flails prior to operation, damaged or missing flails must be replaced immediately before using the machine. **Never operate the machine or attempt to run the rotor with flails missing.**

# 1.0M COMPACT FLAIL HEAD

## OPERATION

### Material Thickness Cutting Limitations

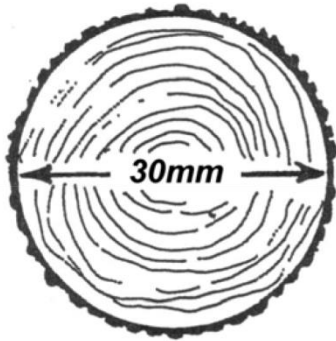

Soft



Hard

### Roller Positions

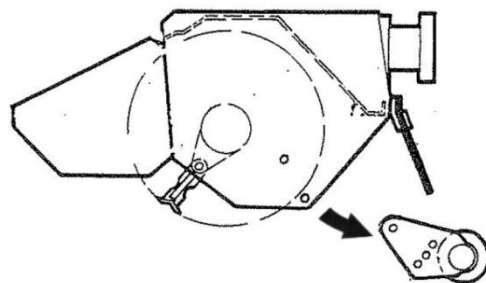
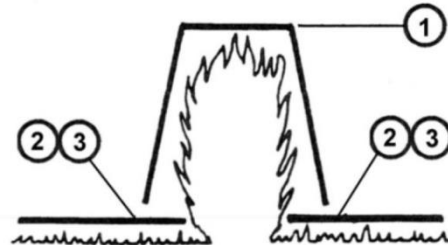
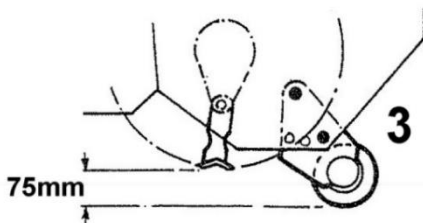
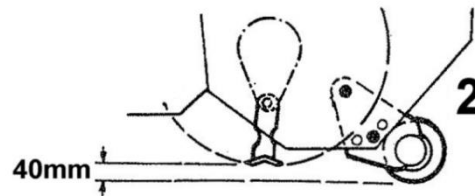
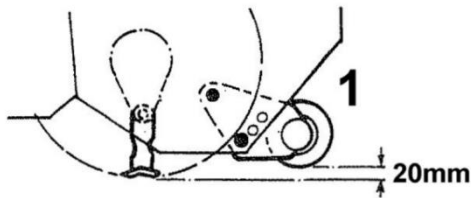

**NEVER** use the flailhead  
with the roller removed

### Preliminary Precautions

Inspect the work area prior to operation, remove all hazardous materials and note the locations of immovable obstructions.



# I.0M COMPACT FLAIL HEAD

## FLAILHEAD ARRANGEMENT – GRASS & VERGE MOWING

### Roller Height

The roller position must always be set below the level of the skids, or rotor if skids are not fitted, i.e. in positions 2, 3, 4 or 5, - refer to roller positions on previous page.

### Rotor Direction

When mowing the rotor must always cut with an upwards rotation.

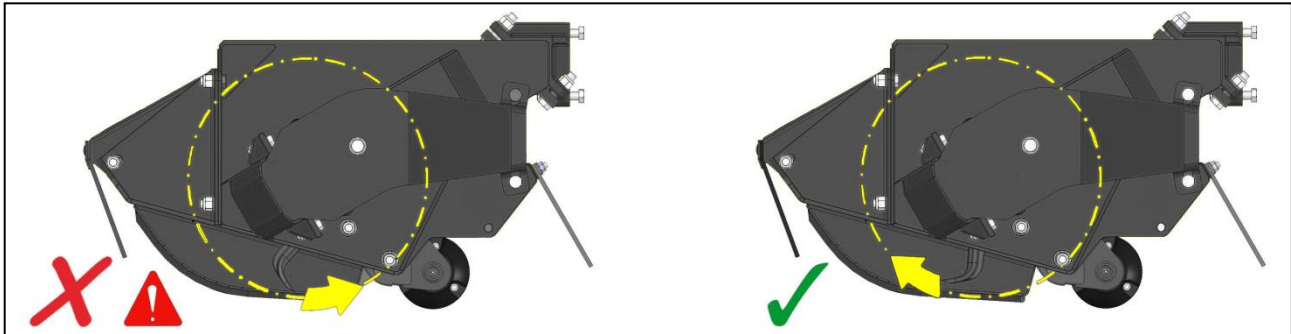

### Front Hood

The front hood has 4 adjustment positions for height – the lowest possible position which allows the material to be cut to enter the head should always be used.

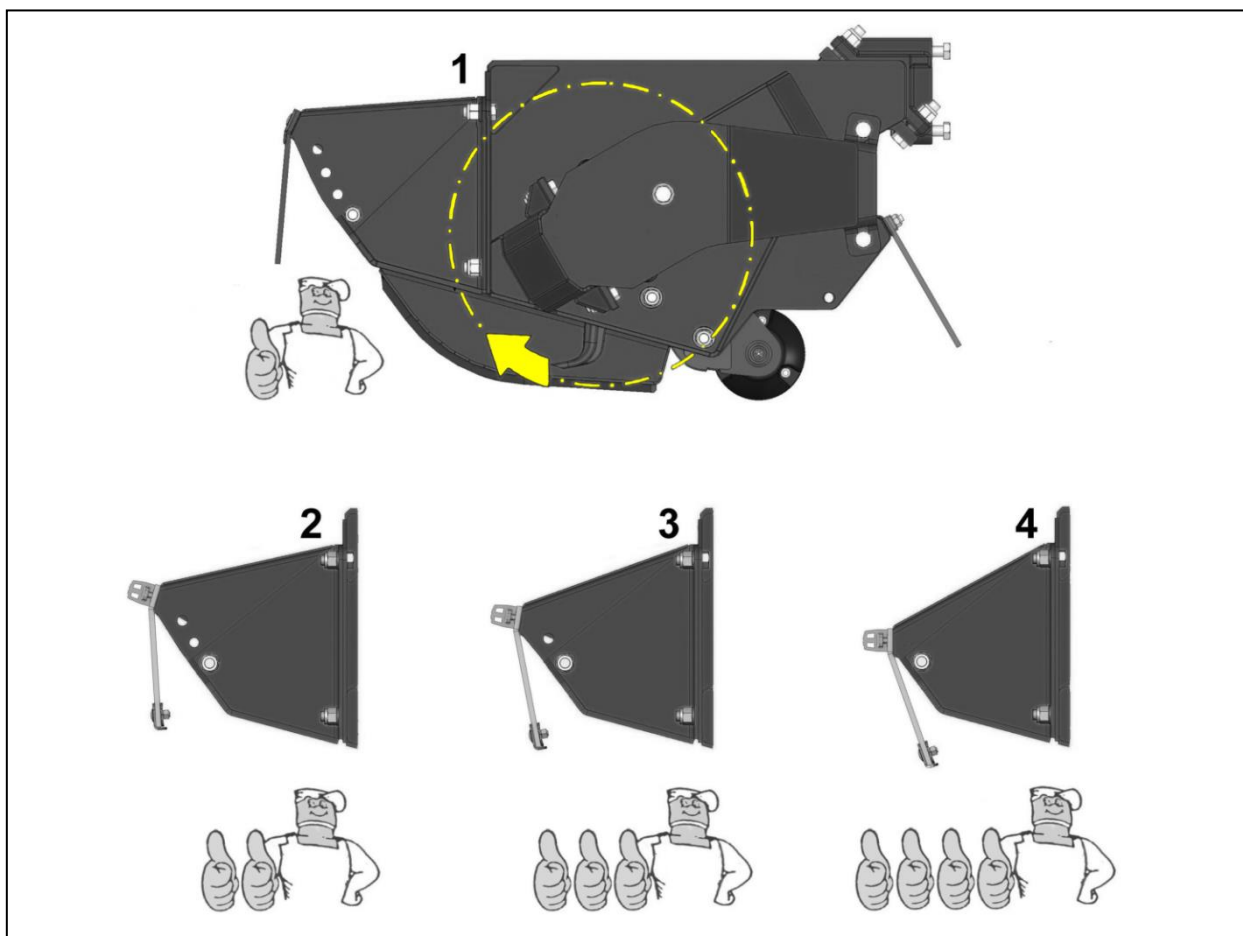

# 1.0M COMPACT FLAIL HEAD

## CAUTION

Before attempting grass mowing ensure the flail head is set up correctly.

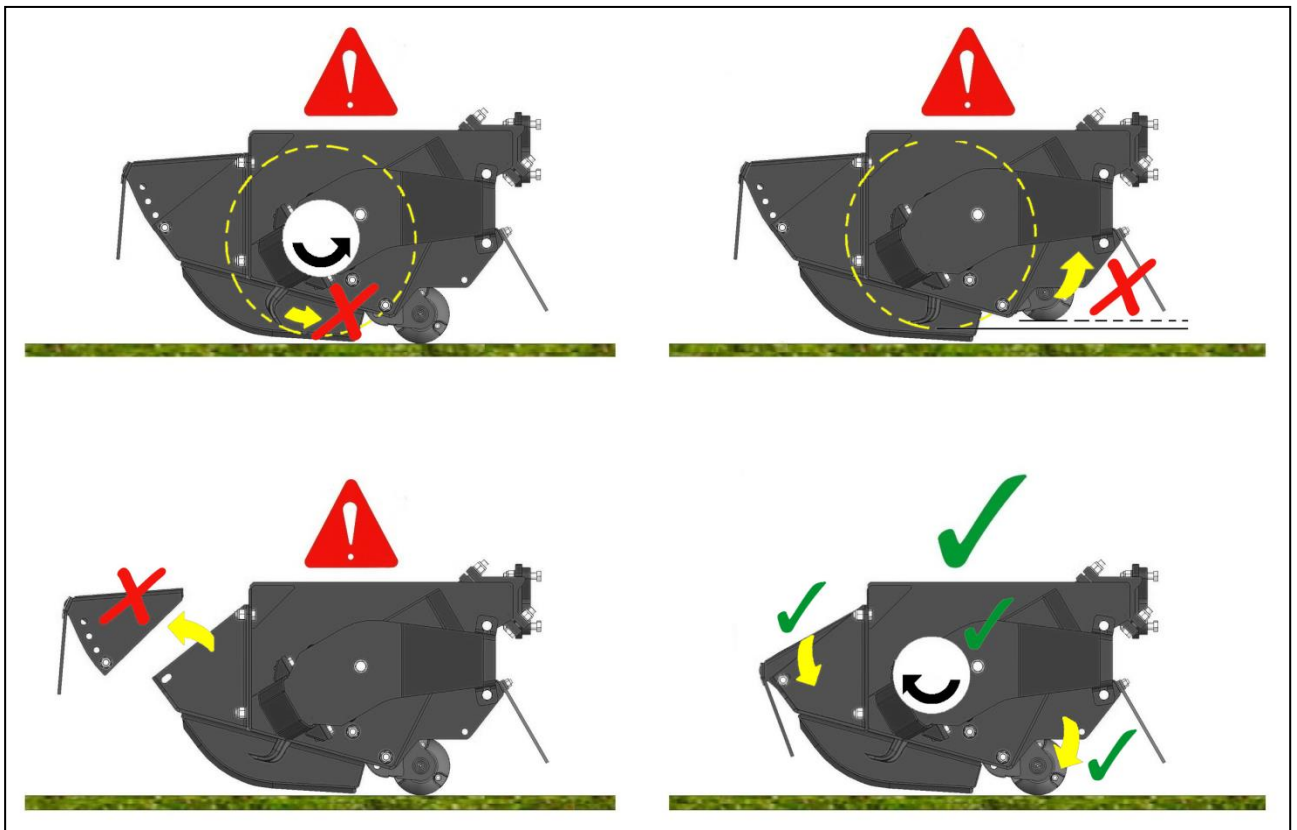

## TRACTOR FORWARD SPEED

The material being cut determines tractor forward speed. Forward speed can be as fast that which allows the flail head sufficient time cut the vegetation properly. Too fast a speed be indicated by over frequent operation of the breakaway system, a fall off in tractor engine revs and a poor finish to the work leaving ragged uncut tufts and poorly mulched cuttings.

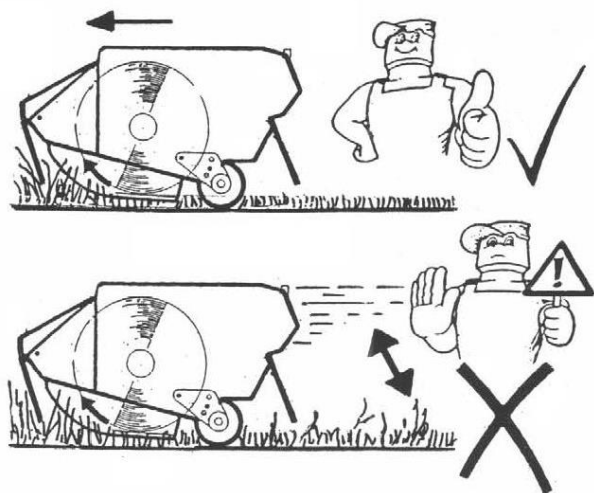

as  
to  
will

# 1.0M COMPACT FLAIL HEAD

## Front Hood - Verge Mowing

For verge mowing a front hood and front flap kit must be fitted and adjusted to a height that will minimise the distance materials and/or unspecified objects can be accidentally ejected. Skid kit, rear roller and rear flap must also be fitted for all mowing duties.

## Hood/Flap Height Setting

To reduce the distance that objects can be ejected from the machine during work, the front hood and flaps should be set at the lowest possible setting that will still allow the work materials to efficiently enter the head but should not be above the recommended maximum height.

The recommended maximum height is calculated as follows; at a forward distance of 2 metres from the flail/material contact point, the line of sight of the flail tips, *beneath the front flaps*, should not be visible above a height of 0.5m. Refer to illustrations below.

## Maximum Hood/Flap Height for Verge Mowing

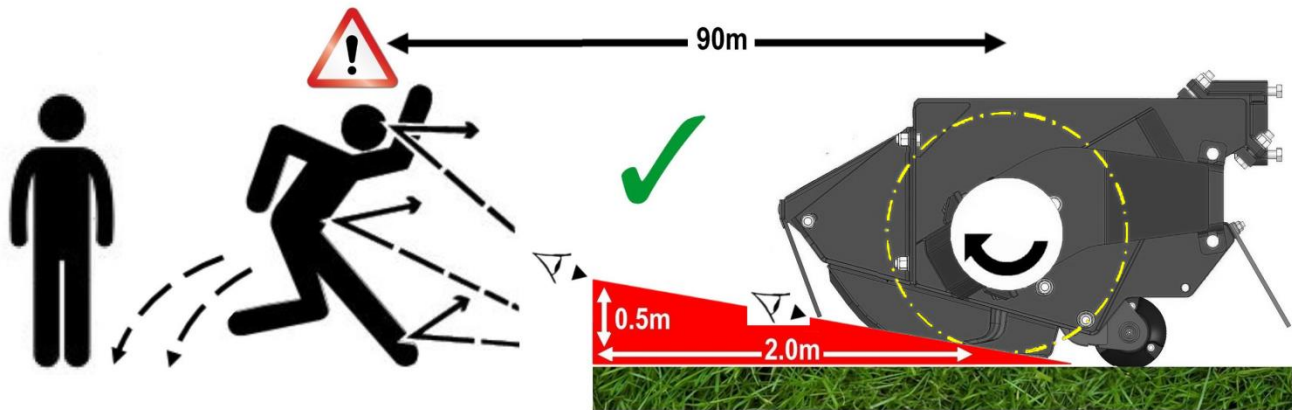

## Unsuitable Hood/Flap Height for Verge Mowing

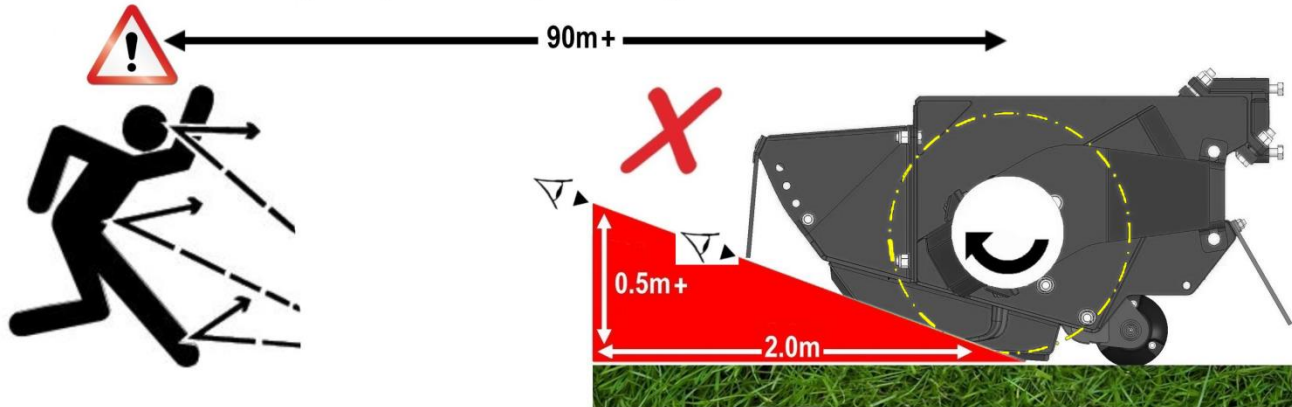

Ensure all flaps are in good condition; excessively worn, damaged or missing flaps must be replaced immediately before use.

# 1.0M COMPACT FLAIL HEAD

## Danger Zone – Verge Mowing / Mowing in Public Areas

For verge mowing and mowing duties in public places the front hood and flap must be positioned at the specified recommended height for verge mowing. If persons or animals come within 100m of the working machine, forward travel must be halted immediately and the rotor switched off; operations must not be resumed until they are clear of the danger zone. Caution must be adopted at all times when working in these types of areas as the operator's vision of the danger zone can be interrupted by corners and obstacles.

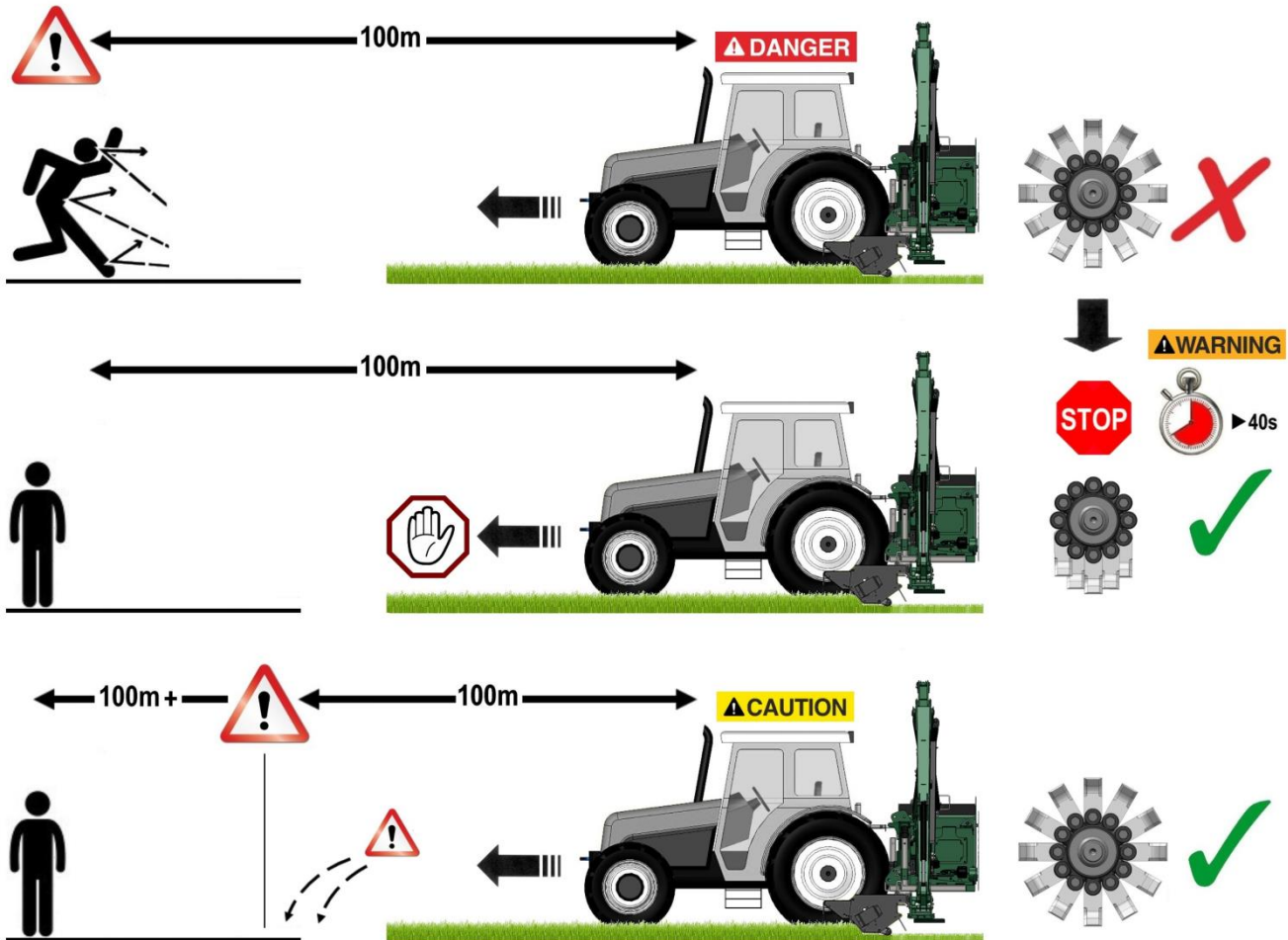

**⚠ DANGER** Forward travel and rotor operation must be halted immediately when persons and/or animals are within 100m of the working machine.

# I.0M COMPACT FLAIL HEAD

## FLAILHEAD ARRANGEMENT - HEDGE CUTTING (Standard Duty)

### Roller Height

The roller position must always be set above the level of the rotor in positions 1 - refer to roller positions page.

### Rotor Direction

For the best finish the rotor should cut with an upwards rotation.

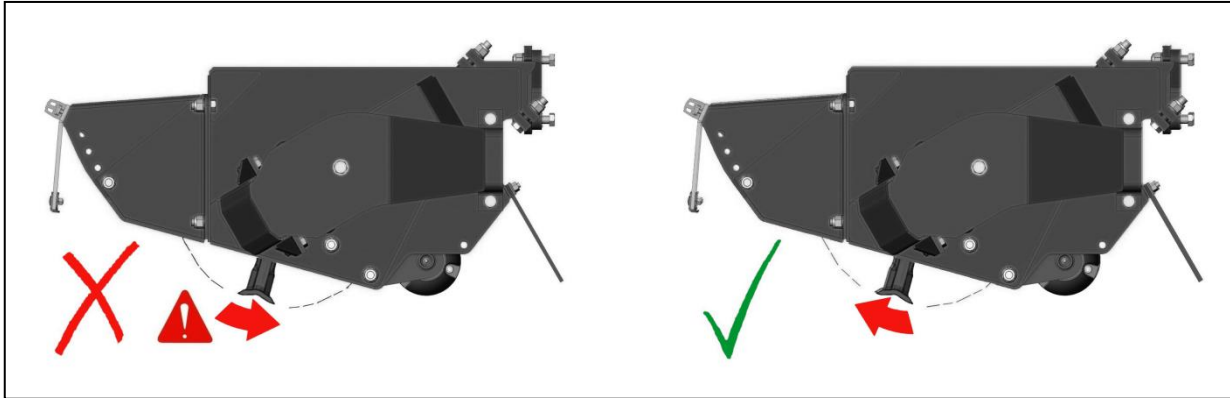

### Front Hood

On universal heads the front rubber flaps, and skids if fitted, may be removed to aid the entry of the material to be cut into the flail head.

The front hood has 4 adjustment positions for height – the lowest possible position which allows the material to be cut to enter the head should always be used.

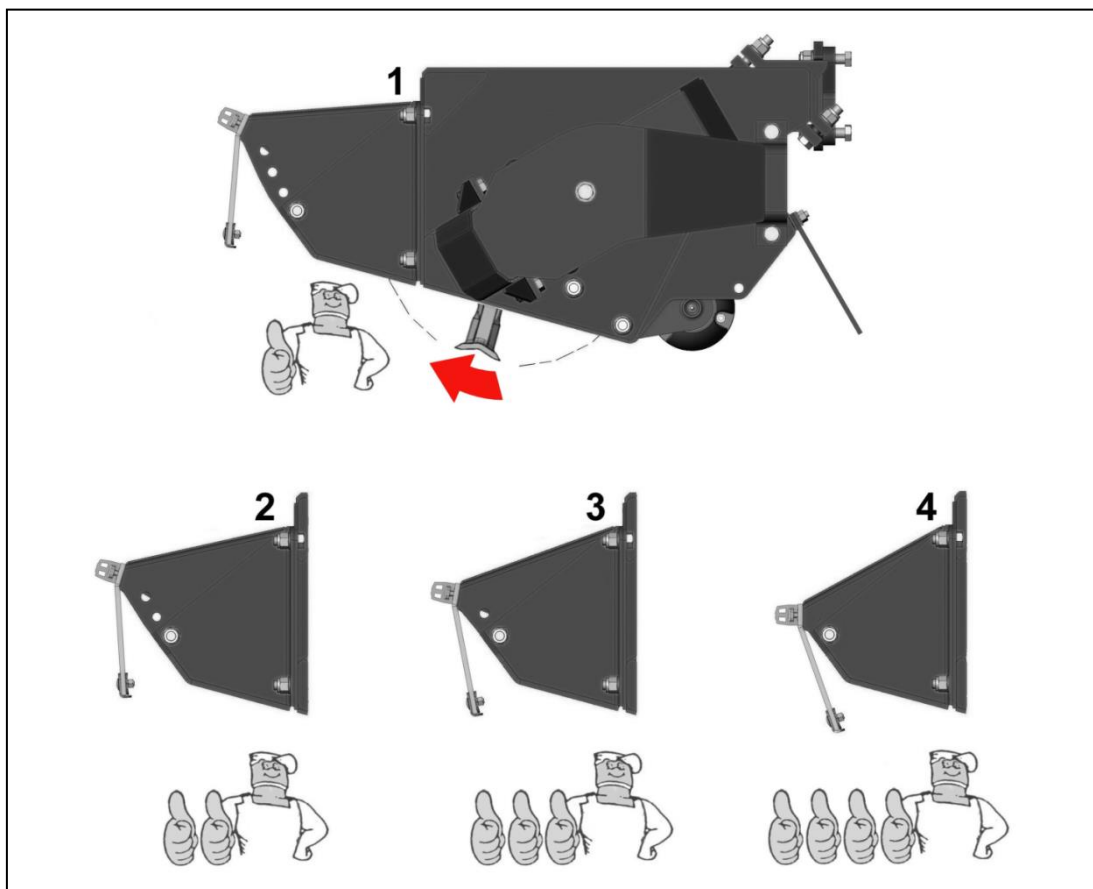

Operate with front hood in lowest possible position that allows material to be cut to enter the head.

# 1.0M COMPACT FLAIL HEAD

**CAUTION** Before attempting hedge cutting ensure the flail head is set up correctly.

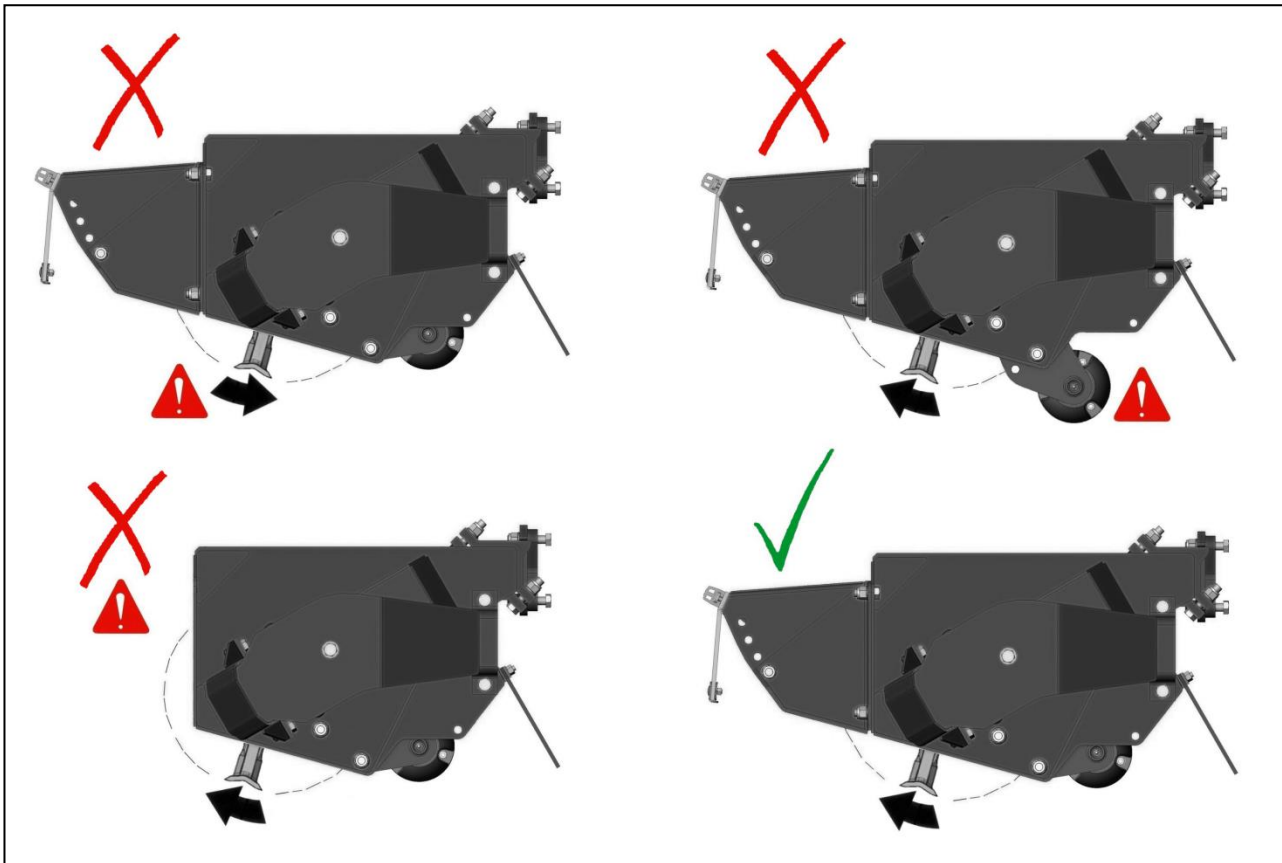

## FLAILHEAD ARRANGEMENT - HEDGE CUTTING (Heavy Duty)

### Roller Height

The roller position must always be set above the level of the rotor in positions 1 - refer to roller position page.

### Rotor Direction

Where the size and density of material to be cut makes it necessary for the front hood and carrier plates to be removed to allow the rotor to cut, the rotor must always cut in a downwards rotation. It must be noted that this will result in a poorer finish to the work and will require more power than upward cutting.

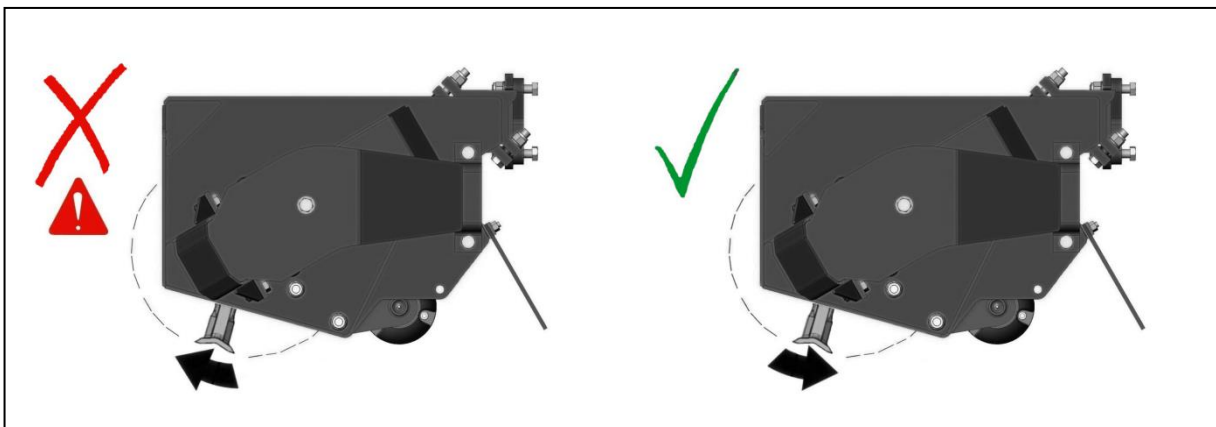

# I.0M COMPACT FLAIL HEAD

## HEDGECUTTING PROCEDURE



**WARNING**

**Never cut on the blind side of the hedge.**  
It is impossible to see potential hazards or dangers and the position of the flail head may allow debris to be propelled through the hedge towards the tractor and the operator.

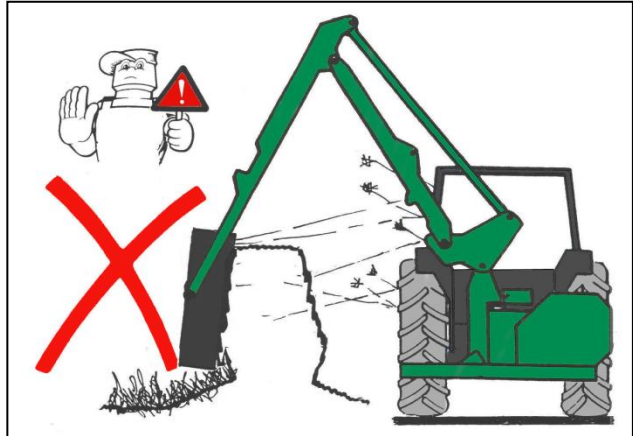

Cut the side and bottom of the field side first. This leaves the maximum thickness of hedge on the road side to prevent the possibility of debris being thrown through the hedge into the path of oncoming vehicles.

Cut the side and bottom of the road side.

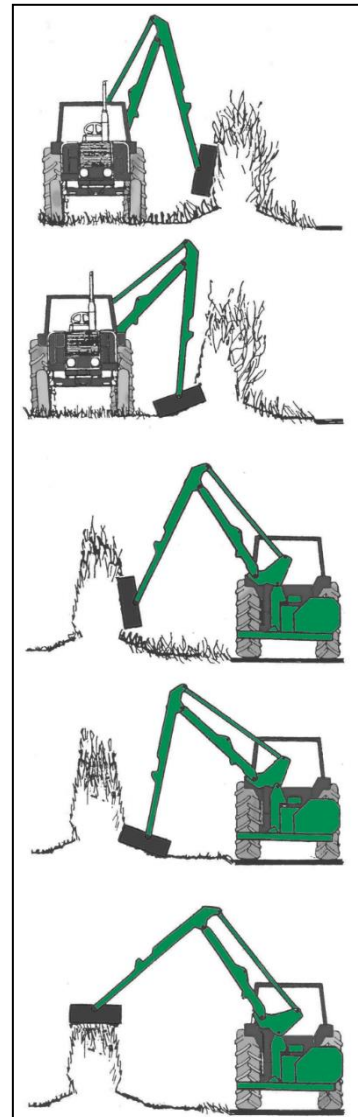

Top cut the hedge to the height required.

# I.0M COMPACT FLAIL HEAD

## MAINTENANCE

---

Frequently inspect the rotor assembly for damaged or missing flails – Never operate or attempt to run the rotor with flails missing, imbalance will cause severe vibration and can rapidly damage the rotor shaft bearings. As an emergency measure, if a flail is broken off or missing, removal of an opposing flail on the opposite side of the rotor will retain the balance. Replace the flails at the earliest possible opportunity and always replace in opposite pairs. Never match up a new flail with a sharpened or damaged flail as the latter will be lighter thus causing imbalance of the rotor. Blunt flails absorb more power and leave an untidy finish to the work. They should be sharpened on a grindstone or with a portable grinder periodically. Always wear protective gear when sharpening flails.

Check on a regular basis, prior to operation that all bolts are tight and that torque figures are correct – refer to pre-operational check page details.

### **Lubrication**

Grease daily the points indicated in the illustration below.





Spearhead Machinery Limited

Green View, Salford Priors, Evesham, Worcestershire, WR11 8SW, England

+44 (0)1789 491860 📞 +44 (0)1789 778683 ✉ enquiries@spearheadmachinery.com 🌐 www.spearheadmachinery.com

Registered office: Station Road, Salford Priors, Nr Evesham, Worcestershire, WR11 8SW, England. Registered in England No. 2312982. VAT No. GB 133 8747 53.