

**Spearhead Machinery
Operator Instruction Manual For**

STUBBLE MASTER 500/730

5.0-7.3m cut width, 1000 PTO input

Vegetation control flexwing folding rotary mulcher

8999137EN v1.2

IMPORTANT

Verification Of Warranty Registration

Dealer Warranty Information & Registration Verification

It is imperative that the selling dealer registers this machine with Spearhead before delivery to the end user.

Failure to do so may affect the validity of the machine warranty.

To register machines go to the Spearhead Machinery Limited web site at:

<https://my.spearheadmachinery.com/warranty/machine-registration/>

Should you experience any problems registering a machine in this manner please contact the Spearhead Service Department on 01789 491867.

Confirm to the customer that the machine has been registered in the section below.

Registration Verification

Model Type:		Stubble Master
Model Number:		99 _____
Serial Numbers:	Machine:	S _____
	Cutting Implement:	S _____
	Other:	
Name Of Owner:		
Name Of Installing Dealer:		
Dealer Address:		
Dealer Signature:		
Date Of Delivery / Installation:		
Date Of Warranty Registration:		

IMPORTANT

At the point of transfer of ownership record the above information. Note the serial number of your machine and always quote it in any communication with us or your dealer. (The serial number plate is located on the machine mainframe.) This is particularly important when ordering spares. Remember to include all numbers and letters.

The information given throughout this manual is correct at the time of publication. However, in the course of constant development of Spearhead machines, changes in specification are inevitable. Should you find the information given in this book to be at variance with the machine in your possession, you are advised to contact the Spearhead Service department where up-to-date information will be provided.

The manual can contain standard and optional features and is not to be used as a machine specification. The machine has been tested and is considered safe if carefully used. Ensure your operator is properly trained in its use and maintenance.

(This page is left blank intentionally)

Stubble Master Flexwing Rotary Mulcher

This manual covers the Stubble Master series of trailed flexwing machines which are available in 5.0m, and 7.3m cut widths.

They are all fitted with hydraulic rams which provide a flexwing folding ability making the machine legal for road transportation.

These trailed heavy-duty machines can be specified with various specifications of wheel and blade combinations to suit the end users specific requirements.

These machines are fitted with 1000 rpm and are available with various input shaft and hitch options.

It is essential that the safety guards and chains are always fitted during operation and that the machine is operated in line with the procedures and practices detailed in this manual.

IMPORTANT

This operator's manual should be regarded as part of the machine. Suppliers of both new and second-hand machines are advised to retain documentary evidence that this manual was provided with the machine.

This machine is designed solely for ground vegetation control and must not be used for any other purpose. Use in any other way is considered as contrary to the intended use. Compliance with, and strict adherence to, the conditions of operation, service, and repair, as specified by the manufacturer, also constitute essential elements of the intended use.

This machine should be operated, serviced, and repaired only by persons who are familiar with its characteristics and who are acquainted with the relevant safety procedures.

Accident prevention regulations, all other generally recognised regulations on safety and occupational medicine, and all road traffic regulations must always be observed.

Any arbitrary modifications carried out to this machine may relieve the manufacturer of liability for any resulting damage or injury.

It is potentially hazardous to fit or use any parts other than genuine **Spearhead** parts.

The company disclaims all liability for the consequences of such use which, in addition, voids the machine warranty.

(This page is left blank intentionally)

Contents List

1	Machine Description	10
1.1	Intended Usage	10
1.1.1	Allowed Uses	10
1.1.2	Improper Uses	10
1.2	General Arrangement	11
1.2.1	Stubble Master 500	12
1.2.2	Stubble Master 730	13
1.3	Machine Identification	14
1.4	Rotation Definitions & Conventions	15
1.5	Machine Specification	16
1.5.1	Standard Specification	16
1.5.2	Machine Options	18
2	Safety	22
2.1	Level Of Danger	22
2.2	Terminology	22
2.3	Safe Use	23
2.3.1	Operators Manual	23
2.3.2	Personnel Preparation	23
2.3.3	Tractor and Machine Preparation For Work	23
2.3.4	Work Site Preparation	26
2.3.5	Machine At Work & Observation	27
2.3.6	Transporting The Machine	29
2.3.7	Machine Storage	30
2.4	Safe Maintenance	31
2.5	Safety & Operational Decals	34
2.5.1	Definitions	34
2.5.2	Placement	36
2.5.3	Replacement	37
2.6	Guards	37
2.6.1	Mandatory Guards	38
2.7	Sound	38
2.8	Personal Protective Equipment	38
2.9	The Machine & The Environment	39
2.9.1	Disposal	39
2.10	Proposition 65	40
3	Machine Preparation	42
3.1	Lifting The Machine	42
3.2	Post-delivery/First Use Inspection	43
3.2.1	Tractor Inspection	43
3.2.2	Machine Adjustment	43
3.3	PTO Shaft	44
3.3.1	PTO Setup & Adjustment (first use)	44
3.3.2	Bottoming Out Test	44
3.3.3	Engagement Test	45
3.3.4	Modifying & Shortening The Input PTO Shaft	45
3.3.5	Fitting The PTO Shaft	47
3.4	Wheels & Tyre Installation	47
4	Usage Instruction	48
4.1	Operator Requirements	48
4.2	Tractor Requirements	49
4.3	Connecting & Disconnecting Hydraulic Hoses & Electric Cables	49
4.4	Hitching & Unhitching The Machine	51
4.4.1	Adjustable Pick-up Hitch	51
4.4.2	Fixed Pick-up Hitch	51
4.4.3	Safety Towing Chain	54
4.5	PTO Shaft	55
4.5.1	Fitting & Removal Of The Input PTO Shaft	55
4.5.2	PTO Shaft Specifications	58
4.6	Unfolding & Folding The Machine	58
4.7	Setting Up The Machine	60

4.7.1	Front To Rear	60
4.7.2	Wings	62
4.8	Setting Cutting Height	64
4.9	Work Site Assessment.....	66
4.9.1	Foreign Debris Hazards	66
4.9.2	Stopping The Machine In An Emergency	67
4.9.3	Bystanders.....	67
4.9.4	Weather	67
4.9.5	Fire.....	68
4.10	Safe Driving Practices.....	68
4.11	Using The Machine	69
4.11.1	Engaging The Power Take-off (PTO)	69
4.11.2	Disengaging the Power Take-off (PTO).....	70
4.11.3	Forward & Power Take-off Speed.....	70
4.11.4	Cornering.....	71
4.11.5	Crossing Ditches & Steep Inclines	72
4.11.6	Un-level Ground	72
4.12	Road Transporting The Machine	73
4.13	Transporting The Machine On A Trailer	74
5	Maintenance	76
5.1	Periodic Maintenance.....	76
5.2	Lubrication & Greasing.....	76
5.2.1	Gearboxes	76
5.2.2	PTO Shaft.....	78
5.2.3	General Machine Greasing Point Locations	80
5.2.4	Greasing Schedule.....	81
5.3	PTO Shaft.....	81
5.3.1	Size Adjustment & Fitting To The Tractor	81
5.3.2	Greasing	81
5.3.3	Input PTO shaft - Bearing Ring Replacement	82
5.3.4	Wing PTO shaft - Bearing Ring Replacement	86
5.4	Slip Clutch	88
5.4.1	Slip Clutch Disassembly & Servicing	88
5.4.2	Freeing Seized Clutch Plates	91
5.4.3	Clutch Settings.....	92
5.5	Blades & Anti-Scalp Dishes	93
5.5.1	Blade Options	93
5.5.2	Blade Inspection	93
5.5.3	Blade Sharpening & Straightening.....	95
5.5.4	Blade Removal & Replacement.....	95
5.5.5	Blade Bolt Inspection.....	96
5.5.6	Anti-scalp Dish Inspection	97
5.5.7	Anti-scalp Dish, Blade & Blade Carrier Removal & Replacement.....	98
5.6	Hydraulic Components.....	101
5.6.1	Ram Inspection.....	102
5.6.2	Wing Ram Replacement	102
5.6.3	Axle Lift Ram Replacement.....	104
5.6.4	Hoses.....	106
5.6.5	Machine Hose Diagrams	107
5.7	Wheels, Hubs & Tyres	108
5.7.1	Tyre Pressures	109
5.7.2	Hub Greasing	109
5.7.3	Maximum Road Operating Speed.....	109
5.8	Other Key Components	109
5.8.1	Pins & Bushes	109
5.8.2	Skids	110
5.9	Torque Settings.....	110
5.9.1	Nuts & Bolts	110
5.9.2	Hydraulic Fittings	111
5.10	Machine Inspection Record	112
5.11	Machine Storage	114
5.11.1	Preparing The Machine For Storage.....	114

	5.11.2	Returning The Machine Back To Work.....	115
6		Troubleshooting	116
7		Spare Parts	118
	7.1	How To Obtain The Correct Spare Part Numbers	118
	7.2	Spare Parts Ordering	119
	7.3	Dealer Network	119

(This page is left blank intentionally)

1 Machine Description

1.1 Intended Usage

1.1.1 Allowed Uses

The Stubble Master flexwing group of rotary mulchers were developed for large-scale farmers and contractors and are popular with aviation authorities. They are versatile machines that are aimed at stubble management but can also be used for cutting set-aside and pasture as well.

The Stubble Master flexwing group of rotary mulchers are designed for use on level, undulating or inclined ground and for a duty cycle of 1000 hours per annum. They will cut vegetation up to 100mm/4" thickness.

They can be mounted to agricultural tractors with a minimum of 120hp (Stubble Master 500) and 160hp (Stubble Master 730).

1.1.2 Improper Uses



DANGER! Spearhead declines any and all liability for damages caused by the machine to persons, animals or property, resulting from use in any other way than described in this manual, or due to damage caused by negligence or by not observing the instructions contained in this manual.

The machine, due to its typical construction, may also be suitable for uses other than from those foreseen by the manufacturer. For this reason Spearhead has selected, as non-exhaustive examples, a series of improper uses that can be reasonably foreseen, which are:

- Using the machine for hedge cutting.
- Using the machine for amenity mowing purposes.

The uses listed above and those not specifically indicated in this manual, including reasonably foreseeable improper uses, are definitively prohibited.



Figure 1.1 Spearhead Trailed Flexwing Stubble Master
(500 model illustrated)

1.2 General Arrangement

The layout and naming convention used throughout this manual for each of the machines are shown in the table below. The numbering and positioning of the relevant item can be found for the particular machine in Section 1.2.1 for the Stubble Master 500 and Section 1.2.2 for the Stubble Master 730.

Item No.	Description	Item No.	Description.
1	Centre Deck	16	Centre Axle Lift Ram
2	Left-hand Wing Deck	17	Wing Axle Lift Ram
3	Right-hand Wing Deck	18	Tie Bar Adjuster
4	Centre Axle	19	Towing Eye
5	Left-hand Walking Wing Axle	20	Drawbar
6	Right-hand Walking Wing Axle	21	Lifting Blade
7	Splitter Gearbox	22	Starcut Blade
8	Gearbox	23	Anti-scalp Dish
9	Centre PTO Shaft	24	Skid
10	Wing PTO Shaft	25	Chain
11	Input PTO Shaft (With Overrun)	26	Wing Lift Ram
12	Height Stop	27	Balance Bar
13	Walking Axle Wheel Bogie	28	Tie Bar
14	Stand	29	Chain Guard
15	Splitter Gearbox Guard	30	Wing Adjuster

Table 1.1 – Stubble Master Machine Components

1.2.1 Stubble Master 500

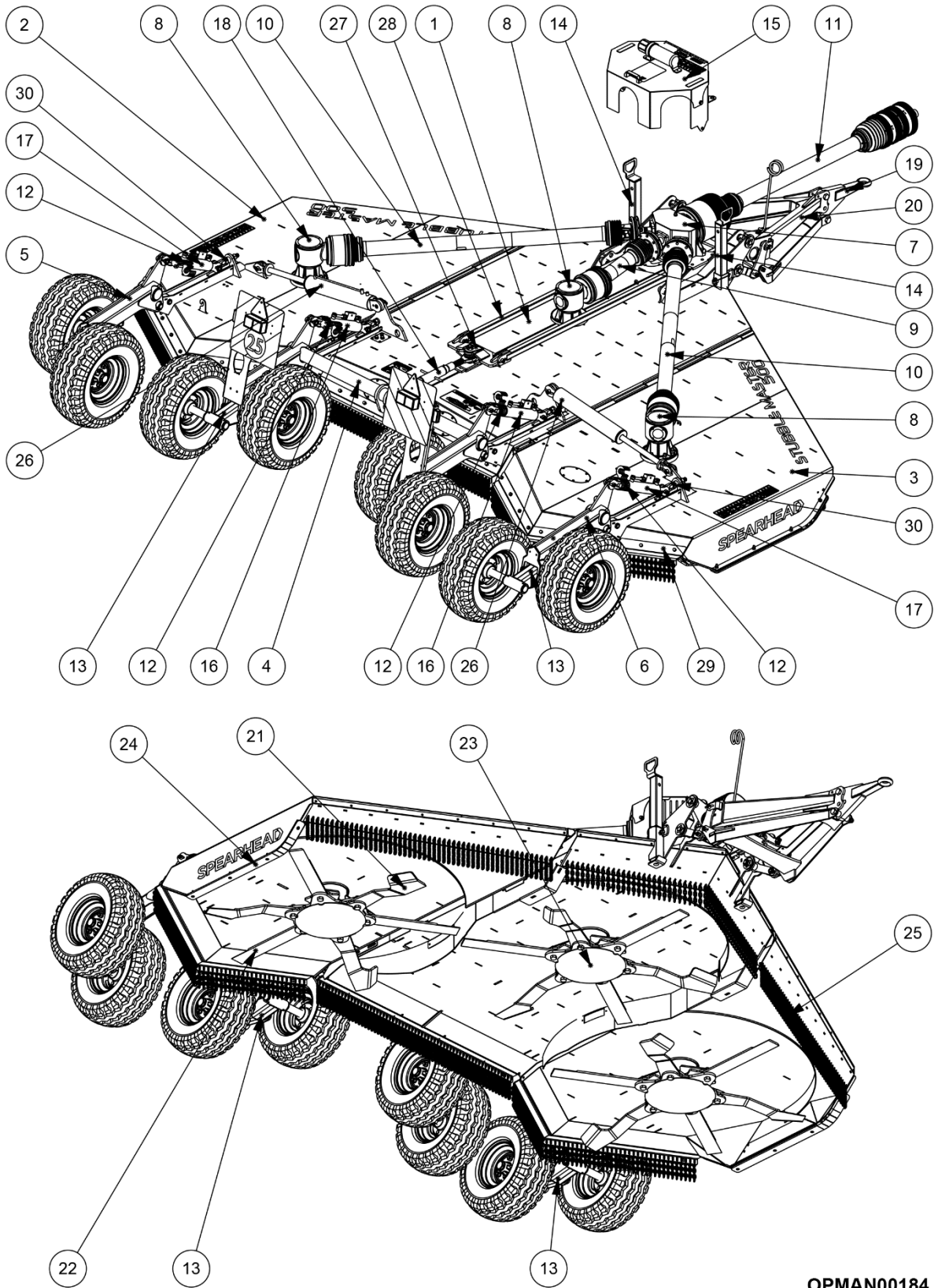

OPMAN00184

Figure 1.2 – Stubble Master 500 General Arrangement

1.2.2 Stubble Master 730

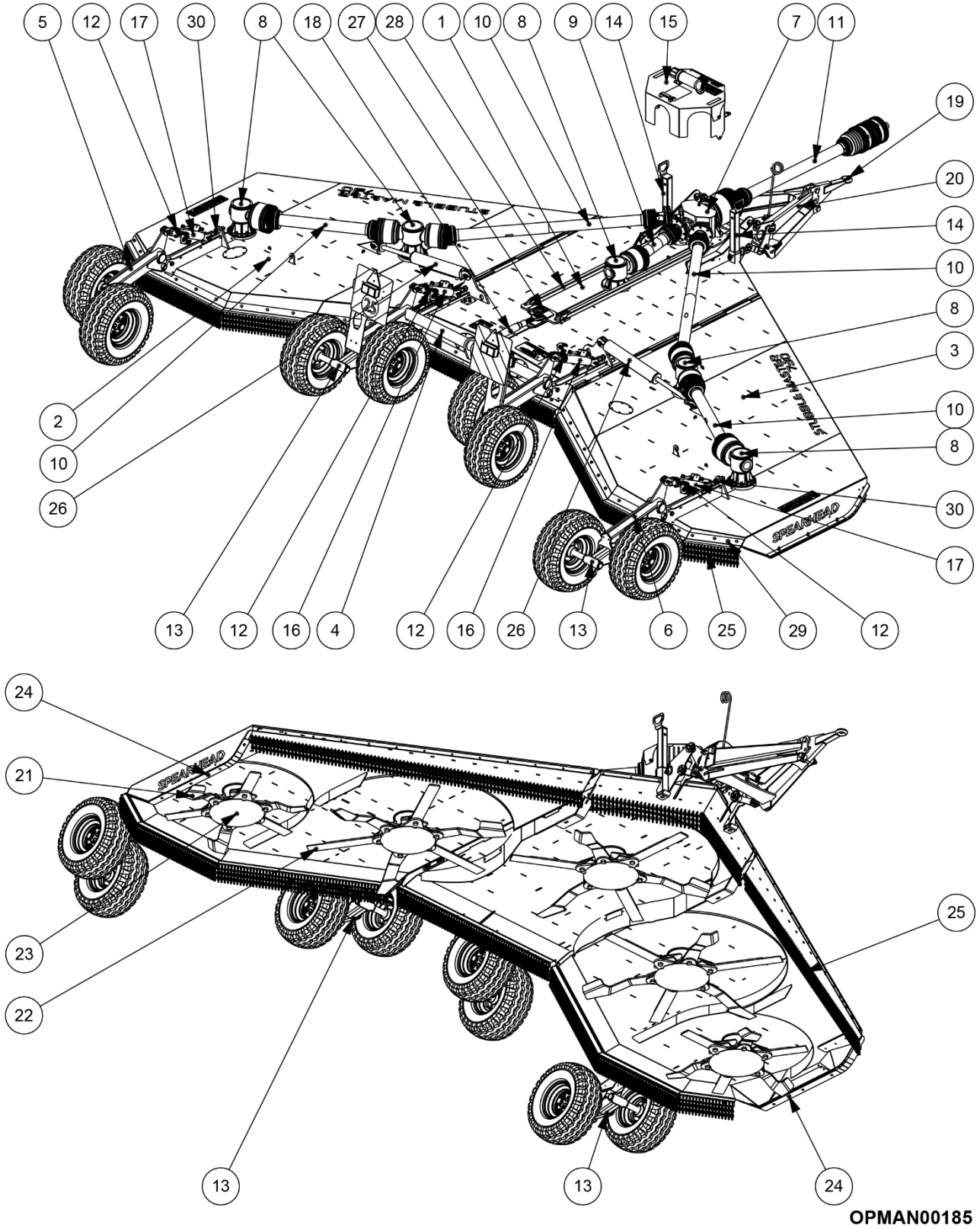

OPMAN00185

Figure 1.3 – Stubble Master 730 General Arrangement

1.3 Machine Identification

Each machine is equipped with a serial plate; see Figure 1.4 that includes the following data in this order:

1. UKCA Conformity Marking.
2. Machine Whole Goods Code (WGC).
3. Serial number of the machine.
4. Mass in kg.
5. Production Year (year of construction).
6. Design conformity standard.
7. Machine Product Group Code.
8. EU Authorised Representative QR scan code.
9. Manufacturer marking with name and address.
10. EAC Eurasian/Russian Conformity Marking.
11. EC European Conformity Marking.

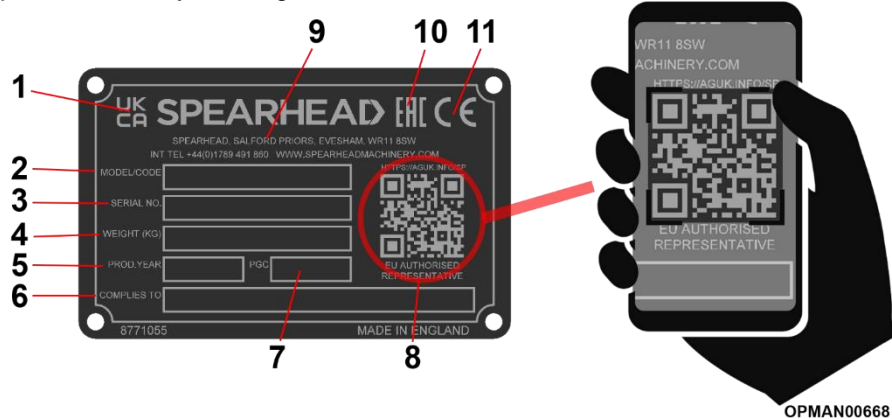

Figure 1.4 – Serial Plate

Data on the Spearhead manufacturer's plate should always be referred to when requesting assistance and/or requiring replacement spare parts.

This data can identify the machine and its characteristics and specification for its particular time of manufacture, certifying that it responds to current regulations. For this reason the plate should never therefore be removed nor be used for other purposes; if the machine is dismantled, it should be destroyed to prevent any form of abuse.

By utilising a smart phone and scanning the Authorised Representative QR scan code found on the right-hand side of the serial plate (ref 8, Figure 1.4) using a suitable QR scanning App, you can find details for Spearhead Machinery authorised representatives for its various territories.

The serial plate is located near the front of the left-hand side of the centre deck; see Figure 1.5.

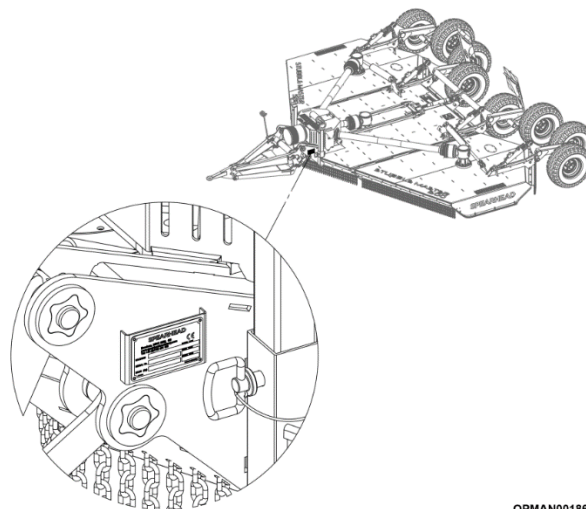

Figure 1.5 – Serial Plate Location
(500 model illustrated)

1.4 Rotation Definitions & Conventions

This instruction manual refers to relative rotational directions. The terms clockwise and anti-clockwise are defined by looking down at the machine from above, with the tractor being at the front; see Figure 1.8. To eliminate confusion the following definitions will be used throughout this operator's manual.

In order to create a consistent and quality cut and through-flow of material through and out of the machine, Stubble Master machines have anti-clockwise and clockwise rotating rotors which are in turn fitted with left-hand (LH) and right-hand (RH) blades. The rotation direction of each of the rotors is stated in Figure 1.6 for the Stubble Master 500 and Figure 1.7 for the Stubble Master 730.

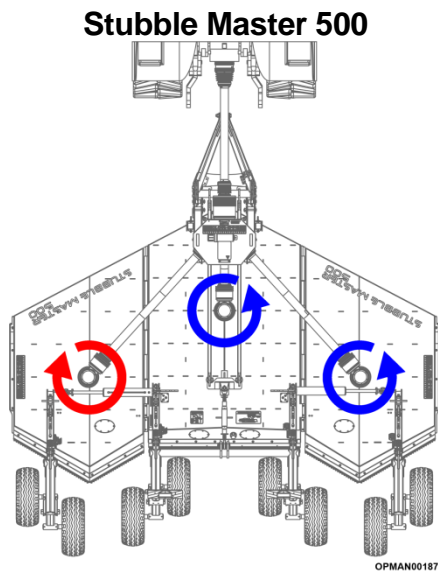

Figure 1.6

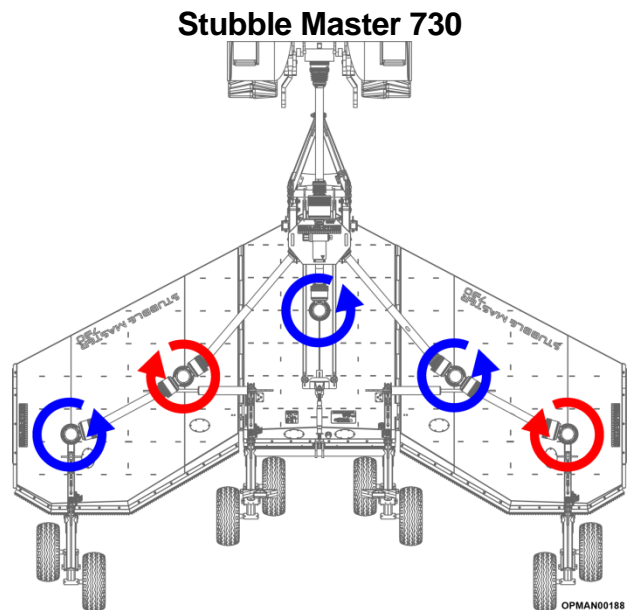
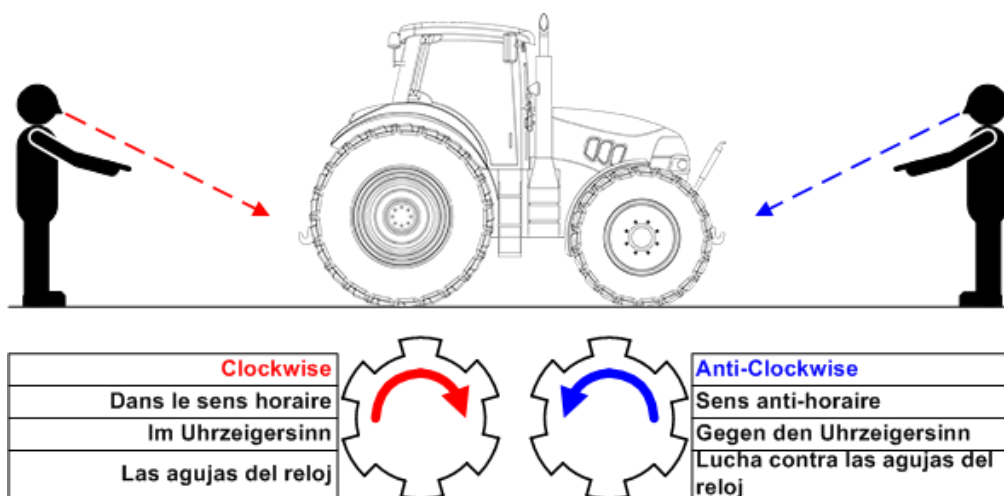

Figure 1.7

Additionally, other references to 'clockwise' and 'anti-clockwise' actions by the operator conform to international right-hand thread conventions for 'screw down' and 'un-screw' respectively.

This convention also extends to the definition of PTO drive rotation from the prime mover, see Figure 1.8.



OPMAN00009

Figure 1.8 – Tractor PTO Shaft Rotation Definitions

1.5 Machine Specification

1.5.1 Standard Specification

Stubble Master		500	730	
Tractor	Recommended Minimum Tractor HP	120hp/89kW	160HP/119kW	
	PTO	1000 RPM		
Machine (1) (2)	Speed	1000 RPM		
	Size	44.5mm (1 ¾ inch), 20 spline		
	Protection	Overrun clutch		
Machine (1) (2)	Mass	2920kg (6438lbs)	3660kg (8069lbs)	
	Hitch	Multi-positional drawbar		
	Cutting Width (A)	5.06m (16' 7")	7.26m (23' 10")	
	Working Width (B)	5.20m (17')	7.44m (24' 5")	
	Working Length (C)	5.83m (19' 1")	6.49m (21' 4")	
	Transport Width (D)	2.97m (9' 9")	2.97m (9' 9")	
	Transport Length (E)	5.78m (18' 12")	6.42m (21' 1")	
	Transport Height (F)	2.19m (7' 3")	3.32m (10' 11")	
	Deck Height (underside to skid)	0.26m (10")		
	Wing Working Angles	30° up/7.5° down		
	Axles	Walking		
	Tailwheels	8		
	Gearbox	Lubricant	EP80-90W or GL-4/GL-5	
		Oil Capacity	Splitter	2.65l (4.66 pints)
Rotor			2.10l (3.65 pints)	
Blades	Lifting 12mm (quantity)	9	15	
	Starcut 12mm (quantity)	9	15	
	Tip Speed	80mps (15748 fpm)	81mps (15945 fpm)	
Cutting Capacity	Height	25-400mm (1"-16")		
	Diameter	100mm (4")		
Driveline	Approval	ASAE Category 6		
	Protection	2-plate slip clutch on rotor gearboxes	2/4-plate slip clutch on rotor gearboxes	

Table 1.2 – Stubble Master 500/730 Standard Specification

Notes:

- (1) Spearhead constantly reviews and improves product designs and reserve the right to change this information. Actual machines may vary from the above specification. Contact your Spearhead Sales representative if you have any queries.
- (2) All dimensions are determined from computer models, so actual measurements may vary slightly.

The following figure guides for working dimensions (Figure 1.9), and transport dimensions (Figure 1.10), are illustrated using a Stubble Master 500.

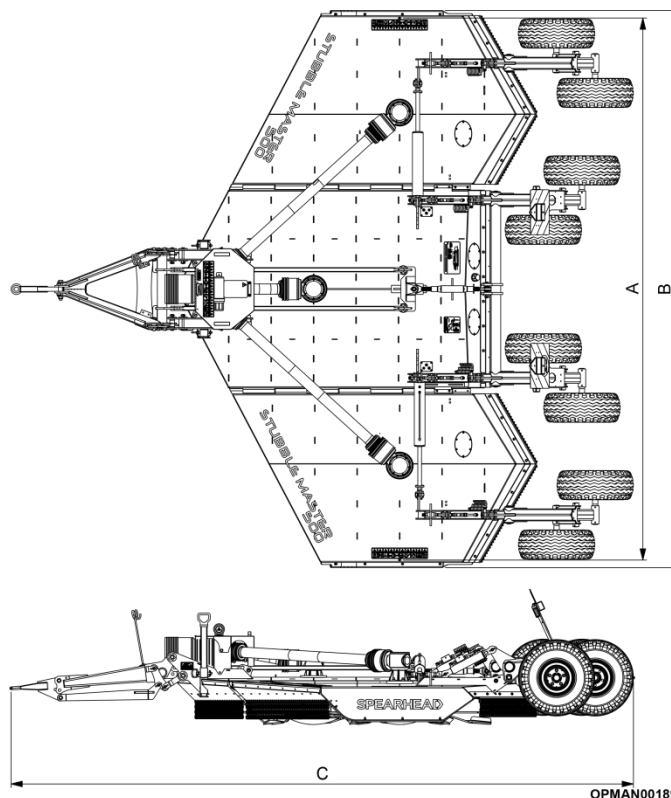

Figure 1.9 Working Dimensions

NOTE: These illustrations for working and transport dimensions are illustrated by a Stubble Master 500 for visual purposes only.

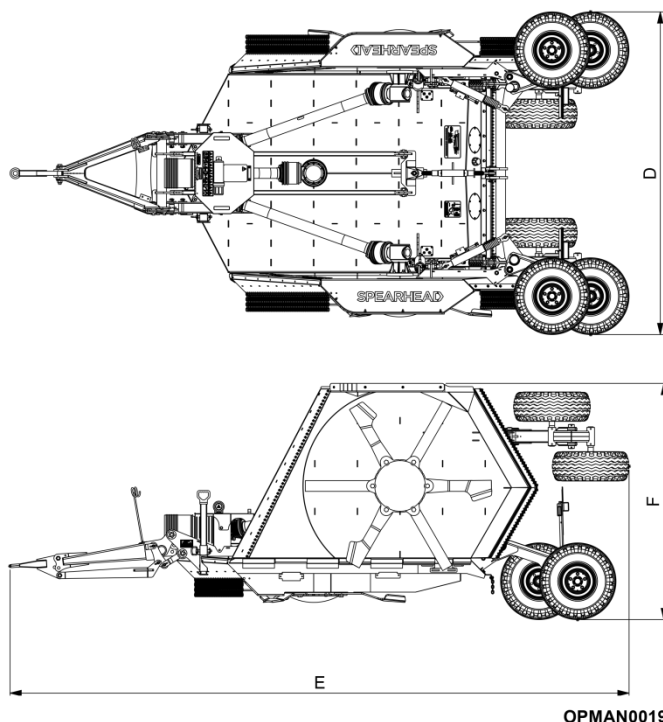



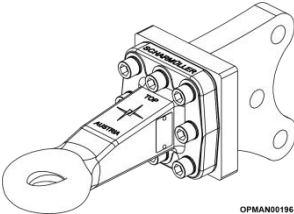
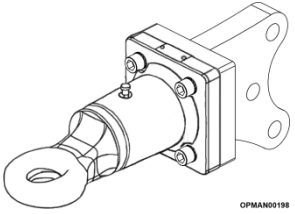
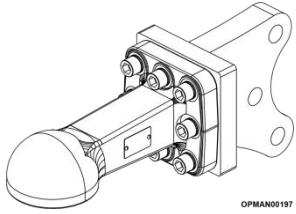





Figure 1.10 Transport dimensions

1.5.2 Machine Options

Stubble Master machines can be ordered in a variety of different specifications to fit the particular user's requirements.

Option	Picture		
1.5.2.1 Input PTO Shaft			
	6 Spline	8 Spline	21 Spline

Option	Picture		
1.5.2.2 Towing Eye			
	Standard	Swivel	K80

Option	Picture		
1.5.2.3 Wheels/Tyres			
	Standard	Optional	
	Implement Tyre	Forklift Truck Tyre	Aramide Implement Tyre

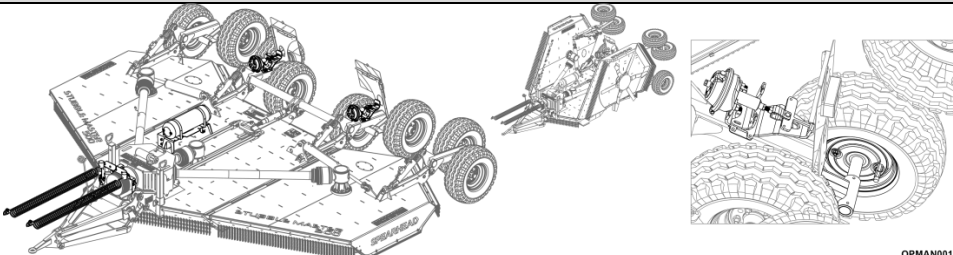
Option	Picture
1.5.2.4 Air Brakes	

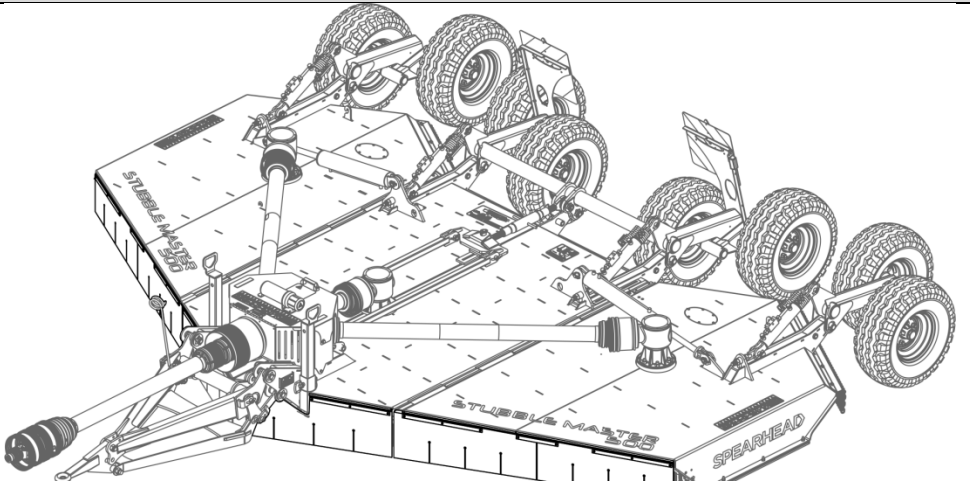
Option	Picture
<p>1.5.2.5 Front Flap Kit</p>	

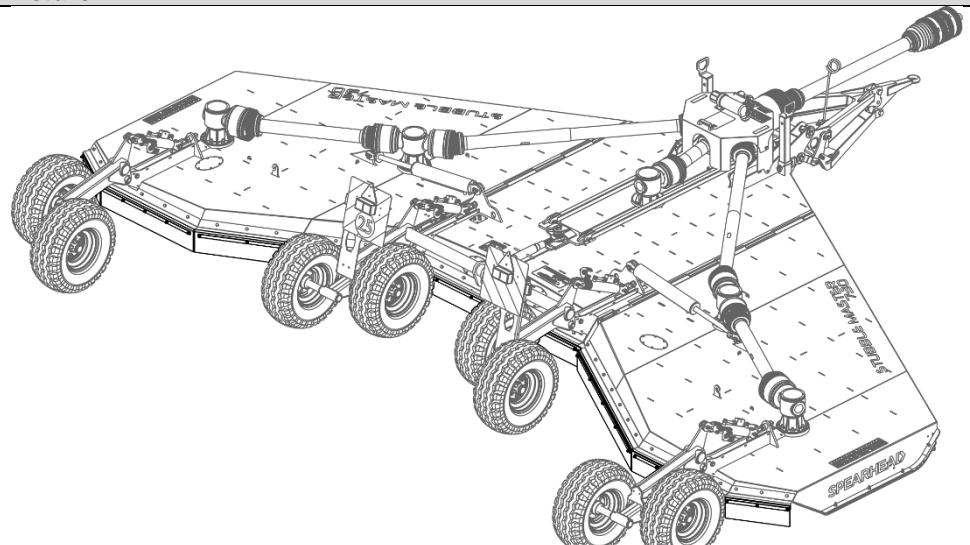
Option	Picture
<p>1.5.2.6 Rear Flap Kit</p>	

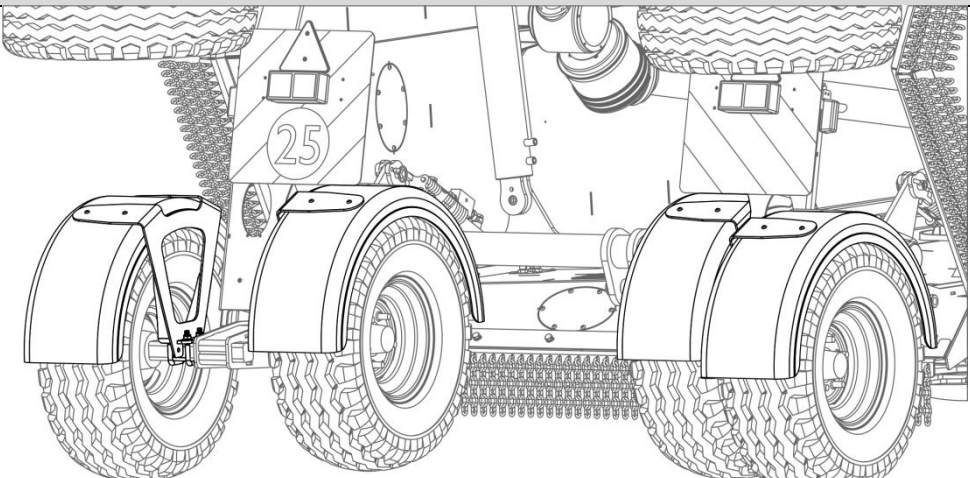
Option	Picture
<p>1.5.2.7 Mudguard Kit</p>	

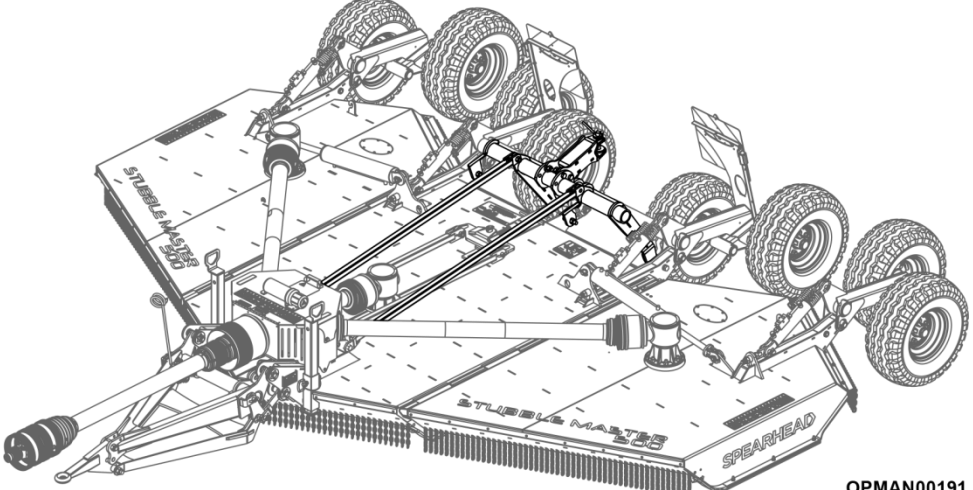
Option	Picture
1.5.2.8 Rear Drawbar	 <p>OPMAN00191</p>

(This page is left blank intentionally)

2 Safety

2.1 Level Of Danger

The operator must read, understand and follow all of the Safety instructions. Serious injury or death may occur unless care is taken to follow the warnings and instructions provided. The level of safety is indicated in three levels and the following notation is used throughout this operator instruction book;



DANGER! Level 1; alerts for imminent death or critical injury.



WARNING! Level 2; warns of serious injury or possible death.



CAUTION! Level 3; indicates possible injury.

IMPORTANT: Special instruction related to the machine, tractor or the working environment

NOTE: Special instruction related to the machine, tractor or the working environment

2.2 Terminology

The indicated levels of danger refer to specific risk situation that may occur during machine use and may involve the same machine, the operator and any exposed persons. With the purpose of highlighting situations or operations that may result in risks, the meanings of terms used in this manual are indicated here:

- **WORKING ZONE:** Any area in and/or around a machine where the presence of an exposed person constitutes a risk to the health and safety of said person.
- **BYSTANDER:** A person fully or partly in a hazardous area.
- **OPERATOR:** The person or personnel in charge of the installation, the operation, the adjusting, the cleaning, the repairing and the moving of the machine.
- **USER:** the person, entity or company, who purchased or rented the machine and intends to use it according to the intended use foreseen by the manufacturer.
- **SPECIALISED PERSONNEL:** any person specifically trained and approved to carry out maintenance or repair interventions that require particular knowledge of the machine, its operation, the installed safety devices, intervention modes. It must be capable of recognising danger present on the actual machine, therefore avoiding at risk situations.
- **RISK:** a combination of the probability and seriousness of injury or damage to health which can arise in a dangerous situation.
- **GUARD:** a part of the machine that is used to specifically guarantee protection by way of a material barrier.
- **PROTECTION DEVICE:** a device that reduces risk (unlike the guard) either on its own or together with the guard.
- **INTENDED USE:** the use of the machine in accordance with the information provided in the operators manual.
- **REASONABLE FORESEEABLE MISUSE:** the use of the machine different to the information provided in the operator's instructions, which may be the result of readily predictable human behaviour.
- **GENUINE SPEARHEAD DEALER/ AUTHORIZED TRACTOR DEALER:** The Genuine Spearhead Dealer/ Authorized Tractor Dealer, legally authorised by the Manufacturer, is formed by specialised staff able to carry out all types of assistance, maintenance and repair work, even of a certain complexity, required to maintain the machine in perfect working order.



WARNING! Carefully read the guidance as stated in this manual relating to safe use. If the instructions described are not followed, a situation may arise which causes irreparable damage to the machine or property, or injury - even severe - to people or animals. Spearhead declines all responsibility for damage caused by not complying with the safety and injury prevention regulations described below. Spearhead also declines any responsibility for damage caused by improper use of the machine and/or as a result of modifications made without prior authorisation by the manufacturer.

2.3 Safe Use



DANGER! It is prohibited to use the machine in ways that are different from the indications contained in this operators manual.

Never operate the tractor or machinery until you have read and completely understood this manual and the tractor operator's manual and each of the safety messages given and those displayed on the tractor or implement.

Safety is of utmost importance to the manufacturer and should be of the same level of importance for the operator/owner. Spearhead machines have been designed to ensure the greatest level of protection to operating personnel and bystanders. However, in practice implementing the safety as guided in this operator manual is up to **you**. Only **you** can prevent serious injury or death from unsafe practices.

2.3.1 Operators Manual



2.3.1.1 **DANGER!** It is prohibited to use the machine in ways that are different from the indications contained in this operators manual.



2.3.1.2 **IMPORTANT:** Read, understand and follow the safety messages stated throughout this section and the rest of this operator's manual. Serious injury or death may occur unless care is taken to follow the warnings.



2.3.1.3 **IMPORTANT:** It is required that all operators and personnel carrying out maintenance on this machine familiarise themselves with the machine and this operator manual to ensure they are aware of the dangers of incorrect use or improper or incorrect repairs.

2.3.2 Personnel Preparation



2.3.2.1 **DANGER!** It is prohibited to use or have the machine used by personnel that are incompetent and not properly trained in the use of the tractor and machine controls and who are in poor health and physical condition or under the use of drugs or alcohol.



2.3.2.2 **DANGER!** It is forbidden to drive the agricultural tractor attached to the machine or have it driven by personnel without an appropriate driving licence.



2.3.2.3 **CAUTION!** It is mandatory to use suitable clothing; PPE for example. Strictly avoid long or loose clothing that could be caught in any way by moving parts. Wear suitable helmets, glasses, gloves, footwear, etc.



2.3.2.4 **WARNING!** When operating the machine do not wear loose or trailing clothing which may become snagged or entangled in moving parts.



2.3.2.5 **CAUTION!** Wear suitable clothing and PPE to cater for the working environment. In some geographical locations, wildlife such as bees or insects or larger wildlife could impact the wellbeing of the operator, machine and other bystanders. Inspect the work location before commencing work.



2.3.2.6 **DANGER!** Ensure you never smoke or have an open flame near the tractor or machine.

2.3.3 Tractor and Machine Preparation For Work



2.3.3.1 **IMPORTANT:** Before starting, safety checks on tractor and machine must be carried out with regard to: functionality, road safety and accident prevention rules.



2.3.3.2 **CAUTION!** Check that the agricultural tractor on which the machine is installed is of adequate power, weight and configuration, compatible with the model fitted and fitted with a seat belt.

The tractor should exceed the weight of the machine by at least 20%. For machine weights see Section 1.5.



2.3.3.3 **IMPORTANT:** Before proceeding to start work ensure that steering and braking give proper operation and are in good condition.



2.3.3.4 **CAUTION!** Before proceeding to take the machine into the work area ensure that driving vision is not impaired by tractor, cab or implement for clear vision of ground hazards and bystanders while seated in the driver's seat.

Adjust rear view mirrors in order to see clearly the machine and all items behind.



2.3.3.5 **CAUTION!** Where a machine is used in conjunction with tractors not fitted with a glazed safety cab, a clear polycarbonate safety screen together with a mesh guard must be fitted to the tractor between the operator and the cutting unit. A polycarbonate safety screen must be used on cabs where windows are likely to be left open for ventilation purposes. It is essential that cab windows on the operating side, through which the machine is observed, are intact, clean and closed. Otherwise a clear polycarbonate safety screen must be fitted where stubble management operations are carried out.



2.3.3.6 **CAUTION!** Always wears protective, steel toe-cap boots when operating or being anywhere near the tractor or machine.



2.3.3.7 **CAUTION!** If the agricultural tractor has no closed cabin, the operator is required to use extra Personal Protection Equipment. Ear protectors are required and a dust mask if the working ground lifts a considerable amount of dust along with safety glasses. If your health is compromised during work or afterwards, stop immediately and seek professional medical advice immediately.



2.3.3.8 **CAUTION!** If the agricultural tractor has no closed cabin, the tractor must be equipped. The "Rollover Protection Structure" (ROPS) must always be locked in position.



2.3.3.9 **CAUTION!** Ensure that the tractor destined to be used with the machine has a vertical escaping, bonnet mounted exhaust to reduce potential fire risk when the machine is in operation. If the tractor is equipped with a under frame exhaust seek a different tractor of use.



2.3.3.10 **CAUTION!** If two or more tractors/machines are being used in close proximity in the working area, enclosed cabs must be used.



2.3.3.11 **IMPORTANT:** The condition of blades and all guards must be checked before beginning daily work and they must be replaced if damaged or missing before proceeding to use the machine.



2.3.3.12 **IMPORTANT:** Periodically (every 8 hours) verify that the screws and bolts are tightened and secure, especially those that secure the blades.



2.3.3.13 **IMPORTANT:** Using the types of lubricating oils indicated by Spearhead and follow the recommended guidelines of the lubricant manufacturer. Check oil levels and grease points daily to ensure the longevity of your components on your machine following the maintenance section of this operators manual.

Follow the guidance of the lubricant manufacturer with regards to handling oils, solvents, cleansers and other chemical agents.



2.3.3.14 **CAUTION!** Check the machine daily for hydraulic system leaks. If any component in the system is faulty, replace the component before proceeding to use the machine.



2.3.3.15 **CAUTION!** When working with/checking the hydraulic system on the machine always wear safety glasses and impenetrable gloves. Use paper or cardboard to search for leaks and not hands or any other body parts.



2.3.3.16 **CAUTION!** Keep hands and body away from pin holes and nozzles ejecting hydraulic fluid. Ingested or penetrated hydraulic fluid in the body can become gangrenous. Removal must be carried out professionally by a suitable Doctor.



2.3.3.17 **CAUTION!** Ensure all hydraulic hoses, lines and connections are in good condition and tight before applying pressure.



2.3.3.18 **CAUTION!** Relieve hydraulic pressure before disconnecting lines or working on the system.



2.3.3.19 **IMPORTANT:** Before proceeding to take the machine onto the public highway ensure that all tyres are inflated correctly. See Section 5.7.1.



2.3.3.20 **IMPORTANT:** Ensure that the supplied wear pads for the towing eyes are placed between the tractor and machine. If the wear pads are beyond repair, replace before using the machine.



2.3.3.21 **CAUTION!** Ensure that the supplied towing eye specified with the machine is suitable for the hitch on the tractor which is pulling it.



2.3.3.22 **IMPORTANT:** Ensure that the wear skids specified and supplied with the machine are fitted to the machine. If not, replace. Prolonged use of the machine with no wear skids will cause permanent wear to the main deck fabrications.



2.3.3.23 **IMPORTANT:** Check the machine to ensure all safety and instruction decals are in position as stated in Section 2.5.2. Replace any missing or damaged decal prior to proceeding to use the machine by sourcing from a local Spearhead dealer.



2.3.3.24 **IMPORTANT:** To remove the probability of broken drivelines ensure that the input PTO shaft is correctly prepared for first time use, assembled and lubricated. See Sections 3.3 and 4.5.



2.3.3.25 **IMPORTANT:** It is mandatory to use the type of PTO shaft supplied with the machine by Spearhead and for the same type to be sourced again when a replacement is required.



2.3.3.26 **IMPORTANT:** Ensure that before first use and modification of size e.t.c., the PTO shaft is the correct item for the tractor in which the machine is intended to be attached to and is shortened to the correct length required following the guidance in the relevant section of the operators manual.

Spearhead does not accept returns on modified/prepared or used PTO shafts, so please take extended time to ensure the item is correct and safe for the tractor application. See Section 3.3.



2.3.3.27 **IMPORTANT:** Do not use PTO adaptors on input shafts. This can cause examples such as excessive vibration, thrown objects and/or blade and driveline failures due to changes in the machines intended use. PTO adaptors also increase the exposed working length of the PTO shaft increasing the probability of entanglement with external objects. If the shaft is incorrect for the tractor; request another shaft from your local Spearhead dealer.



2.3.3.28 **WARNING!** Never connect the power takeoff unless the tractor engine is stopped.



2.3.3.29 **IMPORTANT:** Do not connect the machine to a tractor with a PTO directly connected to the tractor transmission.



2.3.3.30 **DANGER!** At all times ensure that the PTO shaft guards are in position, securely fitted, in good condition and that the tractor PTO shaft shield is fitted.



2.3.3.31 **IMPORTANT:** Replace any of the PTO shaft or coupling guards if any of the following are evident; cracks or damages or any part of the PTO driveline shaft is exposed. Ensure the PTO shaft guards are not free to rotate and the anti-rotation chains are securely fitted and effective before starting the PTO.



- 2.3.3.32 **IMPORTANT:** Ensure that the clutch plates on each of the machine deck PTO shafts are free and set to the correct setting as stated in Section 5.4.3. This will avoid excessive slippage and clutch plate heating.

If the machine has been laid up for any length of time, there is a risk of the clutch plates rusting and seizing together. It is best practice to check clutch settings daily, even on a brand new machine to ensure that they are correct and to release clutches when the machine is being laid up for extended periods.



- 2.3.3.33 **IMPORTANT:** Make sure that the maximum number of revolutions of the PTO is set to the specific specification of the particular machine in question; 1000 rpm, before powering it. Over-speeding a driveline may result in broken drivelines or blade failure. If in any doubt contact your local Spearhead dealer or Spearhead directly.



- 2.3.3.34 **DANGER!** Do not operate machinery with guards missing. Ensure that the correct guards are properly fitted to the machine and tractor at all times and that they are in good condition and function as they are intended to. If guards are missing; replace before using the machine.



- 2.3.3.35 **DANGER!** It is forbidden to alter, tamper with or bypass any of the components on the machine including the safety devices provided by the manufacturer. e.g. guarding

Spearhead claims no responsibility to damages to operators, personnel or property by the factory fitted guards being not fitted or in poor repair.



- 2.3.3.36 **CAUTION!** Keep protection chains in position at all times. They are an essential part of the machines guarding. The machine must not be operated with any of the chains missing.



- 2.3.3.37 **WARNING!** It is forbidden to deposit items on the machine which can harm persons or animals or damage property should they fall.

2.3.4 Work Site Preparation



- 2.3.4.1 **WARNING!** Verify that the ground on which the tractor moves is level and sturdy, before using the machine.



- 2.3.4.2 **CAUTION!** Ensure the environment where the machine is required to operate has adequate lighting. Insufficient or excessive lighting may pose a risk to the operator or bystanders. Ensure you have at least 90m (300 ft) clear visibility ahead of you to identify passers-by and potential risks and disturbances to yourself and/or tractor/machine and ensure you have sufficient time to adjust/stop.



- 2.3.4.3 **WARNING!** Extreme care should be taken when operating near loose objects such as gravel, rocks, wire, and other debris. Inspect the area before mowing. Foreign objects should be removed from the site prior to beginning work to prevent machine damage to the operator, bystanders or the environment. Any objects that cannot be removed must be clearly marked and carefully avoided by the operator.



- 2.3.4.4 **WARNING!** Inspect the work area for overhead or underground electrical power lines. Gas pipes, other cables and any other kind of structure which could be detrimental to the machine or create risk for operator/personnel/bystanders. These should be either removed, marked to keep away from or if preventative methods cannot be easily placed alternative methods of landscape maintenance should be considered.

If short buried utility lines are located; contact your local utility maintenance provider responsible for the work site and do not use the machine until the issue has been addressed and made safe.



- 2.3.4.5 **WARNING!** Keep all raised wings at 3 metres (10 ft) or greater distance from all power lines and overhead obstructions.



2.3.4.6 **WARNING!** If working in overgrown or high stubble inspect for, remove or mark potential hazards, mow at an **intermediate** height. Then repeat the process of inspection and hazard prevention and mow then at the required **finished** height. Increased work site observation will be required to maintain safety through the mowing operation.



2.3.4.7 **WARNING!** Ensure that there are no fire sources present or near the destined working area of the machine. Do not drive into burning debris if it is present or if the area is freshly burnt out.

2.3.5 Machine At Work & Observation



2.3.5.1 **WARNING!** All operation related to the tractor and machine should always be carried out from the driver's seat with seat belt buckled whether working or transporting the machine on the public highway.



2.3.5.2 **DANGER!** It is forbidden to approach, stand close or touch the machine when the machine is running. It is the operators responsibility to check before starting up the machine and during work that bystanders who may inadvertently get in the way of cut material being thrown are kept away from the tractor and machine. Machines are capable under adverse conditions of throwing objects great distances at high velocity. Stop the rotors until all bystanders are well clear (90 m/300 ft+).



2.3.5.3 **DANGER!** Do not enter the working zone of the PTO shaft when the machine and tractor are running. It is dangerous to approach the rotating parts of the machine.



2.3.5.4 **WARNING!** Never approach the machine or leave the tractors seat until the rotors have completely stopped, the tractor handbrake has been applied and the engine has been stopped.



2.3.5.5 **WARNING!** It is forbidden to abandon the driver's seat on the agricultural tractor with the combustion engine running when the machine is running. The machine should always be monitored from the cab of the tractor.



2.3.5.6 **DANGER!** When lowering the machine ensure bystanders stay clear to avoid crushing.



2.3.5.7 **WARNING!** Adjust mulcher centre and wing decks so they're close and parallel to the ground to ensure that the blades are not exposed when the machine is being operated.



2.3.5.8 **IMPORTANT:** Ensure the tractor is fitted with flashing warning beacons and Slow Moving Vehicle (SMV) sign if required. Check the local jurisdiction to determine what requirements are required to be switched on and shown when the machine is working.



2.3.5.9 **WARNING!** Keep your forward speed to a level appropriate to the operating conditions. High-speed manoeuvres are very dangerous, particularly on uneven ground where there is risk of overturning. Reduce speed in poor towing conditions.



2.3.5.10 **WARNING!** Never operate the machine with the rotor moving in raised or folded transport position, even for short distances.



2.3.5.11 **WARNING!** Never carry passengers in the tractor unless it is fitted with an approved seat and seat belt.



2.3.5.12 **WARNING!** Never carry passengers on the machine.



2.3.5.13 **IMPORTANT:** Do not exceed the mulchers rated cutting capacity and use the machine to cut any non-intended material. See Sections 1.5.1.

If the overgrowth required by the machine to be cut is greater than the machines maximum cutting capacity, use **intermediate stages** of cutting in order to ensure the wellbeing of the

machine and reduce hazardous risks to operator and bystanders **before the final cutting height is achieved.**



2.3.5.14 **WARNING!** Avoid mowing in reverse with the PTO engaged. Disengage the mulcher and raise the machine then reverse. Then lower the machine, engage PTO and drive forward again.



2.3.5.15 **WARNING!** Avoid turning sharply with the machine or lifting the machine which cause the driveline to “knock”.



2.3.5.16 **CAUTION!** Splitter and rotor gearboxes can become very hot when in work. Ensure that the gearbox is sufficiently cool before going anywhere near a gearbox.



2.3.5.17 **CAUTION!** Ensure that the decks of the machine are clear of excess debris. Splitter and rotor gearboxes and other driveline components can become hugely hot when in work and debris could cause risk of a fire hazard.



2.3.5.18 **IMPORTANT:** Ensure that a suitable fire extinguisher is carried inside the tractor at all times.



2.3.5.19 **WARNING!** Pay special attention when working with the machine and do not allow the machine to touch fixed objects such as road drains, walls, shafts, curbs, guard rails, tracks etc. as these could break the blades which could cause debris to be thrown at very high speed from the machine. A fire hazard could be created in contacting objects as well. As a precaution raise the cutting height of the machine to ensure they do not collide when the machine is in work.



2.3.5.20 **DANGER!** **Avoid wire.** It can be extremely dangerous if wire catches in the rotor, and every care must be taken to ensure this will not happen. Inspect the working area before commencing.



2.3.5.21 **WARNING!** Check all key components including blades, blade carriers and anti-scalp dishes. Blades can fail from impact and objects can be thrown at great velocity. Inspect and replace all damaged components with genuine Spearhead parts and ensure the machine is running correctly again before resuming cutting operations.

Stop mowing immediately if blades strike a foreign object.



2.3.5.22 **WARNING!** Do not mow in standing water to avoid possible blade failure.



2.3.5.23 **IMPORTANT:** Stop and do not use the machine when there is vibration in the machine, as this may cause breakage and extended serious damage. Find the cause of the vibration or have it inspected by your local Spearhead dealer and do not use the machine until the cause is identified and eliminated.



2.3.5.24 **IMPORTANT:** During work you may be required to adjust your mowing speed to compensate for changes in terrain such as slopes, grass type and density and depending on the cut height you desire to achieve. You should also adjust your speed to compensate for external factors such as overhead obstructions and debris/foreign objects.



2.3.5.25 **WARNING!** Failure to have sufficient load over the front axle (20% +) or to drive at inappropriate speeds on undulating terrain may result in a loss of directional control.



2.3.5.26 **CAUTION!** Personnel should take regular breaks during work to minimise fatigue and ensure alertness in work.



2.3.5.27 **WARNING!** While the tractor is running all personnel should keep well clear of the area around the machine (90m/300 ft+) as there are numerous crushing, shearing, impact dangers caused by the machine operation.



2.3.5.28 **WARNING!** During work, if the tractor requires refuelling ensure the machine is stopped and the PTO is disengaged, the tractor engine is stopped and it's handbrake is applied and ignition key is removed.

2.3.6 Transporting The Machine



2.3.6.1 **WARNING!** Ensure that the rotors have completely stopped before folding the machine between working and transport position.



2.3.6.2 **WARNING!** Check that the levers/buttons which operate the hydraulic lift are locked into position, to avoid the machine lowering during transport.



2.3.6.3 **WARNING!** Never operate the machine with the rotor moving in raised or folded transport position, even for short distances.



2.3.6.4 **WARNING!** All operation related to the tractor and machine should always be carried out from the driver's seat with seat belt buckled whether working or transporting the machine on the public highway.



2.3.6.5 **IMPORTANT:** Before proceeding to take the machine onto the public highway ensure that all brake lights and indicators are working correctly.



2.3.6.6 **IMPORTANT:** Perform performance tests on the tractor/machine combination and how it will act/perform before taking the machine onto the public highway.

Braking tests in a safe environment are required to be carried out in order to gauge the characteristics of the tractor/machine combination and how it will act/perform in an emergency stop situation.

Determine before taking the tractor and machine onto the public highway of the maximum speed the vehicle can be driven safely. Determine the safe speed the machine can be turned remembering the sharper the corner, the larger the reduction in speed required in order to ensure the machine does not turn over. The machine should not travel faster than 20 mph (32 kmh) in any case.



2.3.6.7 **IMPORTANT:** The tractor and machine will respond different between working and transport position. A machine in transport position will have a higher centre of gravity so will be more likely to become unstable at lower speeds. The operator is required to adjust their driving characteristics/speed in order to ensure safety to bystanders and other vehicles.



2.3.6.8 **IMPORTANT:** Use low speeds and smooth, gradual steering action in order to ensure safety to bystanders and other vehicles when on curves, hills, rough or uneven surfaces or wet roads.



2.3.6.9 **IMPORTANT:** Allow clearance for implement swing while turning.



2.3.6.10 **IMPORTANT:** Before proceeding to take the machine onto the public highway ensure that all tyres are inflated correctly. See Section 5.7.1 for machine tyre pressures.



2.3.6.11 **IMPORTANT:** Before proceeding to take the machine onto the public highway ensure that steering and braking give proper operation and are in good condition.

The tractor should exceed the weight of the machine by at least 20%. For machine weights see Section 1.5.1.

















2.3.6.12 **CAUTION!** Before proceeding to take the machine onto the public highway ensure that driving vision is not impaired by tractor, cab or implement allowing for clear vision while driving the tractor in the driver's seat.



Adjust rear view mirrors in order to see clearly the machine and all items behind.



2.3.6.13 **IMPORTANT:** Before proceeding to take the machine onto the public highway ensure that the machine decks are clear of any cut material collected.

-  2.3.6.14 **IMPORTANT:** Before proceeding to take the machine onto the public highway ensure that the tractor and machine tyres are clear of mud and dirt build up.
-  2.3.6.15 **IMPORTANT:** Before proceeding to take the machine onto the public highway ensure that the drawbar safety chain is in position between the machine and tractor.
-  2.3.6.16 **IMPORTANT:** Ensure the tractor is fitted with flashing warning beacons and they are switched on, if required. Contact the local jurisdiction authority for guidance on machine preparation.
-  2.3.6.17 **CAUTION!** Do not tow the machine with trucks or other vehicles on the public highway.
-  2.3.6.18 **IMPORTANT:** When driving on public roads respect other road users and obey the highway laws of the local jurisdiction.
-  2.3.6.19 **DANGER!** When transporting the machine with the wings raised, ensure that the wing retention strap is fitted correctly to ensure that the wings don't suddenly drop and potentially crush personnel, bystanders and cause an accident with other road users in the event of a mechanical or hydraulic failure or inadvertent tractor operator input.
-  2.3.6.20 **DANGER!** When transporting the machine with the centre deck raised (transport position), ensure that all spacers are placed in the lift rams and the machine is lowered down onto them to ensure that the centre axle doesn't suddenly lower and potentially cause an accident with other road users in the event of a mechanical or hydraulic failure or inadvertent tractor operator input.
-  2.3.6.21 **DANGER!** When transporting the machine with the centre deck raised (transport position), ensure that there is sufficient ground clearance below the machine to make sure the machine doesn't bottom when travelling along uneven terrain, such as speed humps.
-  2.3.6.22 **DANGER!** When transporting the machine do not engage the tractor PTO.
-  2.3.6.23 **WARNING!** Keep all raised wings at 3 metres (10 ft) or greater distance from all power lines and overhead obstructions.
-  2.3.6.24 **WARNING!** Never carry passengers in the tractor unless it is fitted with an approved seat and seat belt.
-  2.3.6.25 **WARNING!** Never carry passengers on the machine.
-  2.3.6.26 **WARNING!** Transport the machine only at safe speeds and at a maximum speed of 20 mph (32 kph). Serious accidents and injuries can result from operating or transporting this equipment at unsafe speeds. Drive for the conditions and reduce speed if required.
-  2.3.6.27 **WARNING!** Failure to have sufficient load over the front axle (20%+) or to drive at inappropriate speeds on undulating terrain may result in a loss of directional control.

2.3.7 Machine Storage

-  2.3.7.1 **WARNING!** It is mandatory to switch the combustion engine off and disengage PTO, lower the machine, ensure that the machine has completely stopped, remove the ignition key from the dashboard of the tractor and engage the parking brake before leaving the driver's seat. Only mount or dismount the tractor when machine/tractor are at standstill and stopped.
-  2.3.7.2 **CAUTION!** When the machine is not in use, use the machine stands in order to support the machine ensuring that the machine is placed on a level ground to ensure the machine is secure and will not move or suddenly fall down. Ensure the stands are not overloaded with excess weight.



2.3.7.3 **CAUTION!** When the machine is not in use, ensure that the wing retention strap is fitted to ensure that the wings don't suddenly drop and potentially crush personnel, bystanders in the event of a mechanical or hydraulic failure.



2.3.7.4 **CAUTION!** When the machine is not in use and not connected to a tractor, use the machine chocks in order to ensure the machine is secure and will not move.



2.3.7.5 **IMPORTANT:** Store the machine in a safe place which is protected from the elements, to ensure its wellbeing and protection from damage to components for when the machine is to be recommissioned and used again.

2.4 Safe Maintenance



2.4.1.1 **WARNING!** It is mandatory to switch the combustion engine off and disengage PTO, lower the machine, ensure that the machine has completely stopped, remove the ignition key from the dashboard of the tractor and engage the parking brake before leaving the driver's seat and engaging in maintenance operations.



2.4.1.2 **DANGER!** Disconnect the PTO shaft connecting the gearbox of the machine to the tractor PTO before starting any maintenance or adjustment.



2.4.1.3 **WARNING!** It is mandatory for the machine to be lifted adequately and with suitable lifting accessories and harness in the positions as stated in Section 3.1 and according to the regulations in force in the country where these operations take place along with the recommendations of Spearhead.



2.4.1.4 **IMPORTANT:** Maintenance on the machine should be performed by only skilled and specialized personnel, in strict compliance with the instructions in this manual, and any worn or damaged parts should be replaced.



2.4.1.5 **IMPORTANT:** Always use genuine Spearhead parts when carrying out repairs and maintenance with thoughts to longevity and reliability of the machine and personnel safety.



2.4.1.6 **IMPORTANT:** Store the machine in a safe place which is protected from the elements, when the work is completed to ensure its wellbeing and protection from damage to components.



2.4.1.7 **DANGER!** When required to work on the machine with the wings raised, ensure that the wing retention is fitted correctly to ensure that the wings don't suddenly drop and potentially crush maintenance personnel in the event of a mechanical or hydraulic failure, especially when working on the underside of the machine.



2.4.1.8 **CAUTION!** Relieve hydraulic pressure before disconnecting lines or working on the system. This can be done by pushing and pulling/pushing the selected tractor lever/button. Only once this has been completed and then suitable safety glasses and impenetrable gloves have been put on can the hydraulic hoses be removed from the tractor.



2.4.1.9 **CAUTION!** When working with/checking the hydraulic system on the machine always wear safety glasses and impenetrable gloves. This also applies when working with gearboxes and gearbox oil. Use paper or cardboard to search for leaks and not hands or any other body parts.













2.4.1.10 **CAUTION!** Keep hands and body away from pin holes and nozzles ejecting hydraulic fluid. Ingested or penetrated hydraulic fluid in the body can become gangrenous. Removal must be carried out by a medical professional.







2.4.1.11 **CAUTION!** Ensure all hydraulic hoses, lines and connections in good condition and tight before applying pressure.



2.4.1.12 **IMPORTANT:** Do not change any factory-set hydraulic settings to avoid component or equipment failures.

-  2.4.1.13 **IMPORTANT:** Do not modify or alter implement functions or components.
-  2.4.1.14 **DANGER!** Do not weld or repair rotating mulcher components such as blade carriers and blades. They may cause vibrations and component failures being thrown from the machine.
-  2.4.1.15 **DANGER!** Replace bent, damaged, cracked or broken blades immediately with new blades.
Do not attempt to straighten, weld or weld hard-facing blades to avoid blade failures and throw broken blades from the machine.
-  2.4.1.16 **CAUTION!** Always wear protective gloves when handling blades, knives, cuttings edges or worn components with sharp edges.
-  2.4.1.17 **CAUTION!** Components such as splitter and rotor gearboxes can become hugely hot when in work. Ensure that the gearbox is sufficiently cool before going anywhere near these components for maintenance. As a precaution though wear gloves and safety glasses when servicing these potentially hot items or any other potentially hot item on the machine.
-  2.4.1.18 **DANGER!** If the underside of the machine is required to be lifted to be worked on ensure that the machine is supported with solid stands. Not via an adjustable hydraulic jack or an overhead crane.
-  2.4.1.19 **DANGER!** If the machine is required to be worked on ensure that the ground is level, sturdy and solid and that the machine is suitably chocked in order to ensure it doesn't move or fall.
-  2.4.1.20 **DANGER!** When folding the machine make sure that personnel are distanced from the machine to ensure they are not hit by falling components; for example swinging blades.
-  2.4.1.21 **DANGER!** Do not run the tractor engine inside. Only run the tractor in open outdoor spaces.
-  2.4.1.22 **DANGER!** Engine exhaust fumes and some of their constituents and certain vehicle components contain or emit chemicals known to the state of California to cause cancer, birth defects or other reproductive harm. See Section 2.10 with regards to Proposition 65.
-  2.4.1.23 **CAUTION!** Ensure maintenance personnel wear suitable PPE clothing when maintaining the machine to ensure a reduced risk of impact or skin injuries. Frequent or prolonged contact with hydraulic oil may cause dermatitis and other skin disorders including (more rarely) skin cancer when not wearing impenetrable gloves. Worn parts may have sharp edges.

Follow the guidance of the lubricant manufacturer with regards to handling oils, solvents, cleansers and other chemical agents.
-  2.4.1.24 **IMPORTANT:** Always replace guards that have been removed for service or maintenance and ensure they are fit for use, give complete protection and work as intended. If not, replace them before proceeding to use the machine.
-  2.4.1.25 **CAUTION!** If maintenance is required on the machine in a location which is high up and inaccessible from the ground; use a secure ladder or raised stands.
-  2.4.1.26 **CAUTION!** Ensure a good footing by standing on solid, flat surfaces when getting onto the machine to carry out work.
-  2.4.1.27 **CAUTION!** Never use the PTO or PTO guards as a step.
-  2.4.1.28 **IMPORTANT:** Comply with the laws in force in the country of installation on the use and disposal of products used for cleaning and performing maintenance on the machine, considering the recommendations of the manufacturer and local guidelines on the given products.



2.4.1.29 **IMPORTANT:** Before returning the machine back to work ensure the machine has been thoroughly checked over using the Machine Inspection Record; see Section 5.10.

Ensure that when the machine inspection is carried out that the machine is stationary and not running.

Where parts are broken, damaged and deemed not fit for use; replace with genuine Spearhead parts using the online Interactive Parts facility at:

<https://my.spearheadmachinery.com/parts/public-interactive-parts-database/>

You will require the machine serial number. Assistance to its location can be found in Section 1.3.

2.5 Safety & Operational Decals

Stubble Master machines are equipped with safety and operational decals warning about residual risks present on the machines that were not possible to eliminate. Some give guidance in how to best operate and care for the machine. Safety decals are yellow in colour and placed in strategic positions around each of the respective dangers. Operational decals are placed in locations close to the respective item required to be maintained. Section 2.5.1 specifies the meaning of each of the symbols contained in the decals and their particular positioning on the machine is stated in Section 2.5.2. The operator must memorise the meaning of these decals.

All decals should be kept clean and replaced immediately if they are fully/partially detached or damaged by purchasing them through a local Spearhead dealer.

2.5.1 Definitions

1.

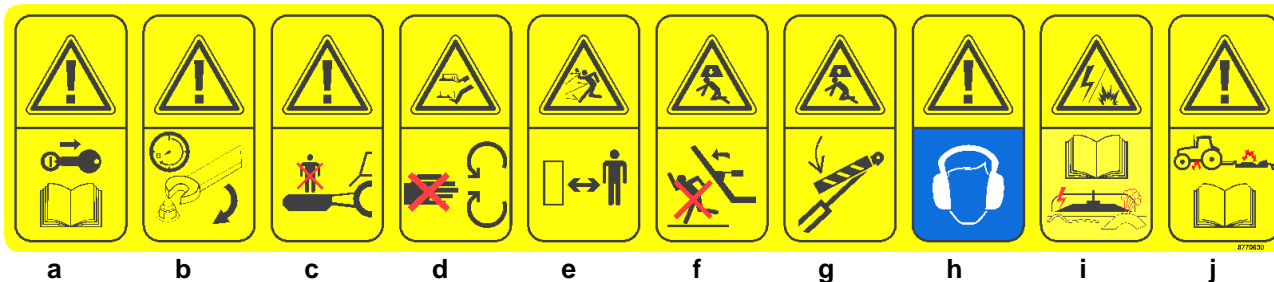

Figure 2.1 – 8770630 Safety Decal

a	Warning: - Remove key, read instruction manual	The original machine operators manual should be read before using the machine giving guidance to operation and maintenance
b	Instruction: - Check the tightness of fasteners	The tightness of all fasteners around the machine should be checked at least once every 8 hours
c	Danger: - Do not stand ride on the machine	The machine should be at no point be ridden on; whether in transport or during work
d	Danger: - Cutting hazard from rotating blades	Personnel should keep at distance from the machine when the machine is operating
e	Danger: - Flying debris	Personnel should keep at distance from the machine when the machine is operating due to the risk of items being flung from the machine
f	Danger: - Crushing hazard if unsupported	Personnel should keep at distance from the machine when the machine is unsupported as of the risk of the wing and other items falling posing potential entrapment or crushing
g	Danger: - Pinch point hazard	Personnel should keep at distance from the machine when the machine is operating as of the risk of entrapment or crushing by components
h	Danger: - Wear ear protection	Personnel should wear hearing protection when in close proximity to the machine in operation to prevent permanent hearing damage
i	Warning/Instruction: - Explosion hazard	Check the working site before proceeding to use the machine.
j	Warning/Instruction: - Clear deck of debris	It is important to ensure that the machine decks are clear of debris to stop the risk of fire. Never drive over fire with the tractor and machine.

Table 2.1 – 8770630 Safety Decal Definitions

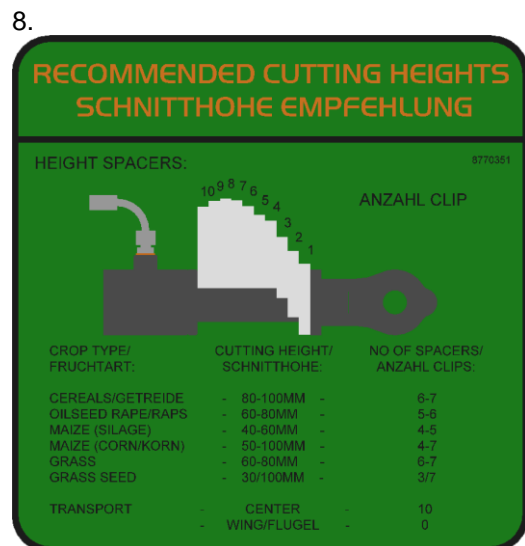
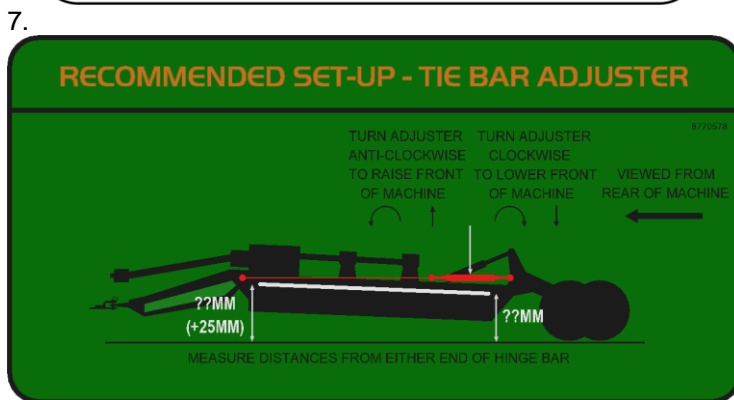
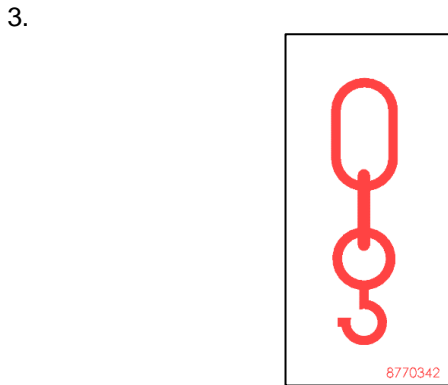
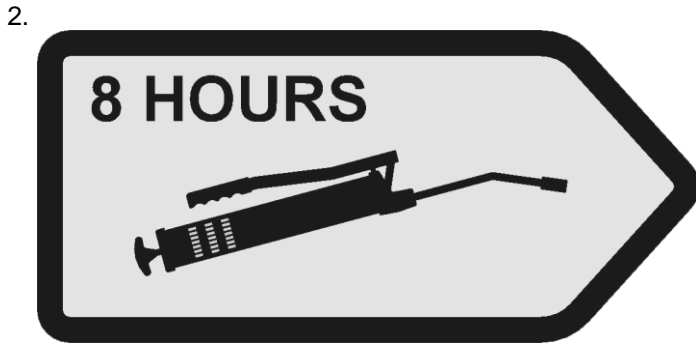

Figure 2.2 – Other Safety & Instruction Decals

2	Instruction: - Grease every 8 hours	Placed and pointed towards components of the machine which should be greased at least once every 8 hours
3	Instruction: - Designated lifting point	Placed at positions on machine where safe lifting should be carried out
4	Instruction: - Clutch setting	Guidance to the correct process of freeing/setting up driveline clutches
5	Instruction: - P65 cancer and reproductive harm	Operating, servicing and maintaining this equipment can expose you to chemicals which are known to the State of California to cause cancer and birth defects or other reproductive harm.
6	Warning/Instruction: - PTO operating speed	Indication to the correct operating speed of the machine when in work. 1000 RPM
7	Recommended Set-Up – Tie Bar Adjuster	Guidance on how to successfully set-up the tie bars of the machine so the machine cuts level front to rear
8	Recommended Cutting Heights	Guidance on how to use the hydraulic ram spacers to gain the correct cutting height for the particular crop desired to be cut

Table 2.2 – Other Safety & Instruction Decal Definitions

For the placement of these decals on each of these machines, please refer to Section 2.5.2.

2.5.2 Placement

Section 2.5.2.1 and 2.5.2.2 state the particular positions safety and instruction decals are placed on each of the Stubble Master machine models.

2.5.2.1 Stubble Master 500

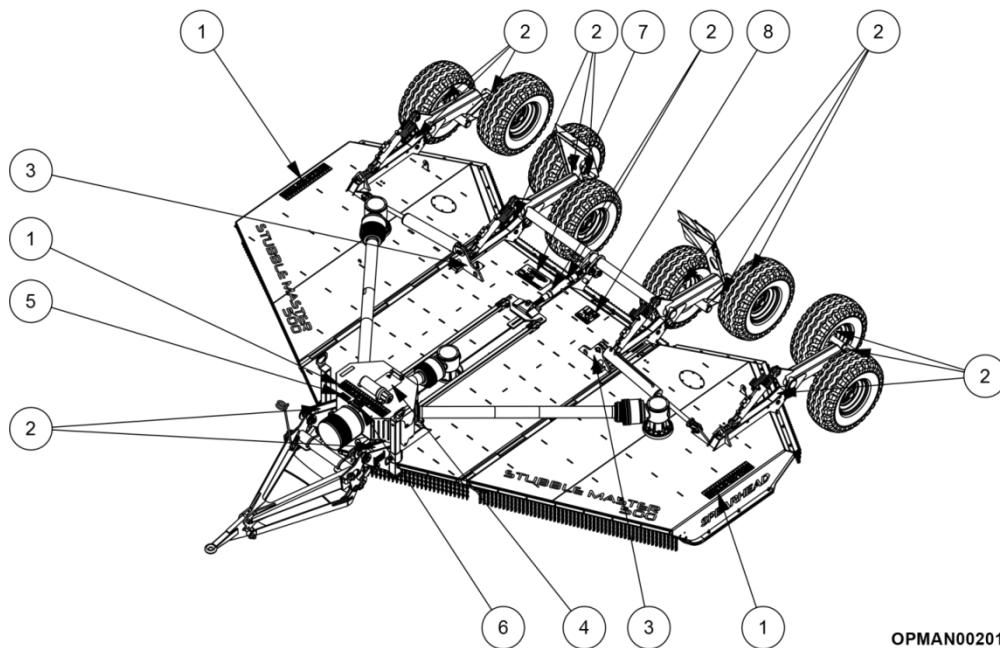

Figure 2.3 – Stubble Master 500 Safety & Instructional Decal Placement

2.5.2.2 Stubble Master 730

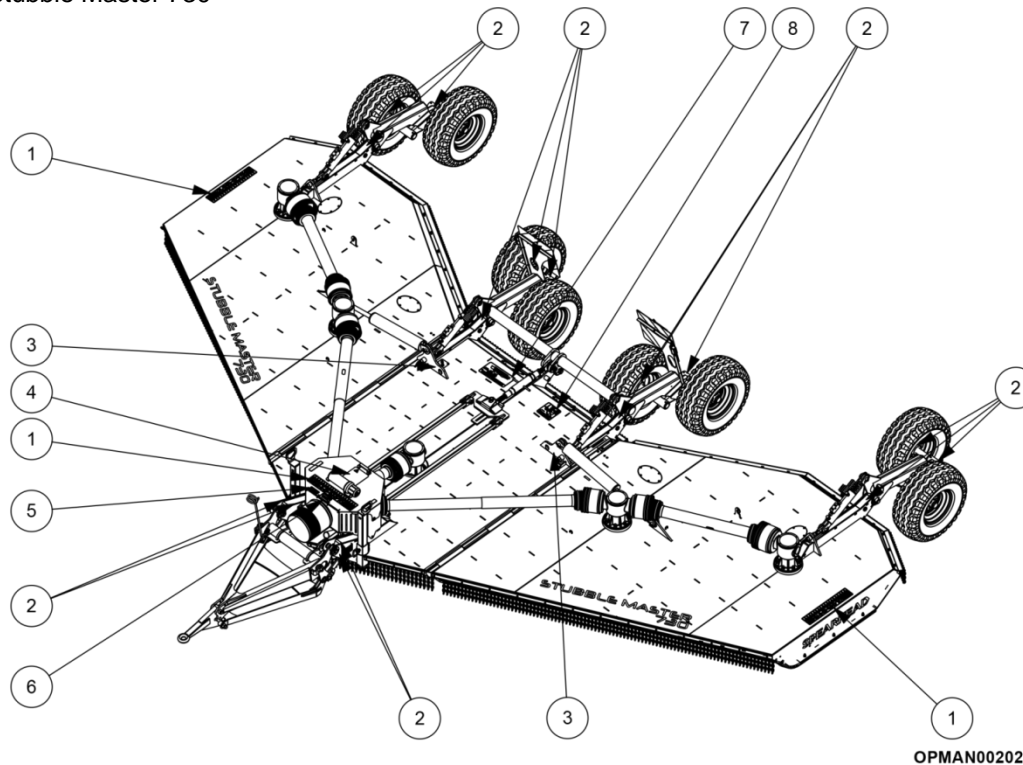

Figure 2.4 – Stubble Master 730 Safety & Instructional Decal Placement

2.5.3 Replacement

It is of utmost importance that safety decals are kept clean and replaced if they are no longer legible, damaged or lost completely. Safety decals can be purchased readily from a local Spearhead dealer.

Spearhead safety decals have the replacement part number found in the bottom right of the decals.

For more extensive guidance on ordering spare parts and how to go about finding the correct part number; see Section 7.

2.6 Guards



DANGER! For safe operation it is essential that that all guards and the protection chains must be kept in position on the machine whenever the machine is running. Spearhead disclaim all responsibility for any damage or injury arising as a result of guards or protection chains being removed, or of guards other than of Spearhead manufacture having been fitted, or of operation of the machine other than in accordance with these instructions.



WARNING! Inspect guards twice daily or immediately damage is suspected.

Always replace guards that have damage or wear which could impair their performance. Typical damage to inspect for is as follows;

Drive guard and side skids	Distorted or with sharp outer edges.
PTO guards	Cracked, missing portions revealing moving parts
Chain guards	Missing chain lengths to permit stones or similar objects to be ejected beneath it in normal conditions

Table 2.3 – Permanent Protection Guard Damages

2.6.1 Mandatory Guards

The General arrangement figure found in Section 1.2 and the list below show the mandatory guards required. These along with the danger decals and warning decals are necessary for safe cutting operations with this machine;

- PTO coupling guards
- PTO shaft guard
- Splitter gearbox guard
- Front metal chain guards
- Rear metal chain guards

2.7 Sound

The air noise level created by the machine under operating conditions was detected using a sound level meter with integrator.

The measurements were carried out in accordance with ISO 1680-2 with the machine. Tests performed under the conditions indicated by the standard produced the following results:

Machine	Tractor With Open Cab	Tractor With Closed Cab
Stubble Master 500	97dB	83dB
Stubble Master 730	97dB	83dB

Table 2.4 – Stubble Master Sound Readings

2.8 Personal Protective Equipment

Operators should be wearing sufficient personal protection equipment (PPE) to protect them from hearing, respiratory and impact damages.

When working in an unsealed cab or where windows and apertures are open to the environment, operators are advised to wear suitable eye and ear protection, a facemask (depending on conditions) and eye protection.

When handling cutting surfaces or hydraulic equipment, operators are advised to wear suitable gloves.

When clearing blockages, clearing wire, or working with pressurised hydraulic components, operators are advised to wear suitable eye protection and suitable gloves.



OPMAN00161

Figure 2.5- PPE Items

Ensure that non-baggy clothing is worn to reduce the chance of entanglement and snagging on components. When working at the work site, but off the tractor unit, operators are advised to wear a 'high-viz' garment.

2.9 The Machine & The Environment

Below are the minimum provisions to be followed in order to reduce the risk of environmental impact connected to the use of the machine:

- If the country where the machine is used foresees specific sound emission limits, it is best to adapt to the provisions in these standards, if necessary, being supplied with suitable protective equipment (earplugs, muffs, etc.).
- **It is mandatory** to respect current legislation of the country where the machine is used, related to use and disposal of lubricants and products used for machine cleaning and maintenance, observing the recommendations of the manufacturer of those products.
- If replacing worn parts or during demolition, one must follow anti-pollution laws foreseen in the country where the machine is used.
- **It is prohibited** to pour products used for cleaning or polluting substances into the sewerage drain, on the ground, in watercourses, or into the environment.
- **It is mandatory** to collect products used for cleaning and polluting substances in appropriate containers, store them and deliver them to companies authorised for their disposal.

2.9.1 Disposal

When Spearhead equipment reaches the end of its economic working life it should be disposed of responsibly, either through an approved recycling centre or by compliance with all regulations in force in the destination territory.

In most instances Spearhead machines can be broken into its constituent parts with the use of basic workshop equipment. Table contains a typical list of constituent materials, together with disposal guidelines.

When undertaking a machine breakdown, take care to ensure that heavy parts are always adequately supported to avoid injury.

To avoid environmental contamination, take containment precautions to retain control of liquids in order.

It is the owner's responsibility to ensure the machine is disposed of in accordance with all applicable regulations.

Material	Typically found in;	Disposal guideline
Steel	Structural components, fixed guards, fasteners and driveline	Can be dismantled and recycled. Take care when handling heavy and/or sharp objects
Aluminium	Pump and gearbox housings, serial number plates	Can be dismantled and recycled. Take care when handling heavy and/or sharp objects. Take appropriate actions for oil contaminated products
Copper	Wiring, electrical components	Can be recycled using appropriate recovery procedures.
Hydraulic oil	Tank, hydraulic components	Dispose of in accordance with all applicable regulations
Rubber	Hoses, flexible guards, seals, 'O' rings	Dispose of in accordance with all applicable regulations
Plastics	Clips, caps, cable ties, decals, filter housings, document holders, bushes, electrical components, plugs, connectors, wire insulation	Dispose of in accordance with all applicable regulations
Filter element	Filter housings	Dispose of in accordance with all applicable regulations
Cork / paper	Gaskets	Dispose of in accordance with all applicable regulations

Table 2.5 – Machine Breakdown Component Disposal

2.10 Proposition 65



Figure 2.6 – P65 Cancer And Reproductive Harm Decal

Operating, servicing and maintaining this equipment can expose you to chemicals including gasoline, diesel fuel, lubricants, petroleum products, engine exhaust, carbon monoxide, and phthalates, which are known to the State of California to cause cancer and birth defects or other reproductive harm.

To minimize exposure, avoid breathing exhaust, do not idle the engine except as necessary, service your vehicle in a well-ventilated area and wear gloves and wash your hands frequently when servicing your vehicle. Battery posts, terminals and related accessories contain lead and lead compounds, chemicals known to the state of California to cause cancer, birth defects or other reproductive harm.

For more information go to www.P65Warnings.ca.gov.

This website, operated by California's Office of Environmental Health Hazard Assessment, provides information about these chemicals and how individuals may be exposed to them.

(This page is left blank intentionally)

3 Machine Preparation

3.1 Lifting The Machine



WARNING! Do not lift by drawbar or axle alone. Damage may occur which will invalidate warranty. Use recommended lifting point locations.

Stubble Master machines should be lifted using the two designated lifting loops found near the rear of the centre deck and the towing eye; as shown in Figure 3.1.

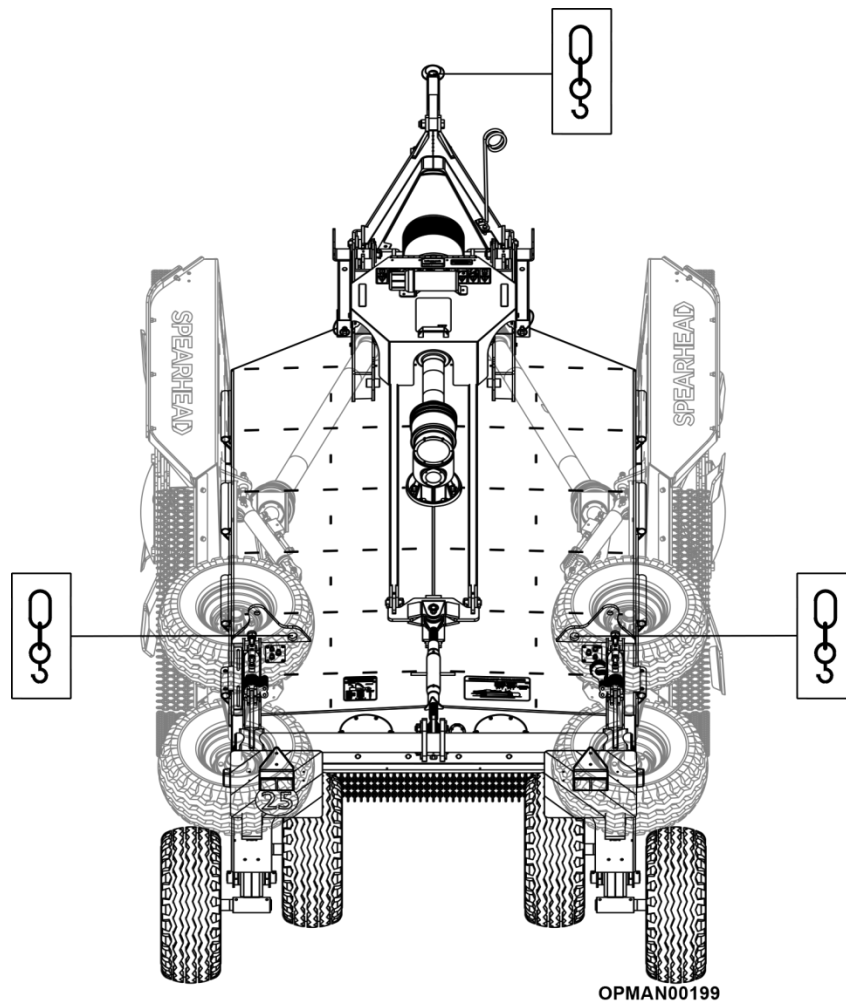

Figure 3.1 Shipping Position – Stubble Master

Ensure that the machine is guided by personnel when positioning the machine to where it is required to be placed. This is to ensure that other equipment/personnel do not get hit by the machine.

Ensure that wherever the machine is going to be positioned afterwards is sturdy and level, so that the machine does not end up becoming unstable and will potentially move or fall over.

Further support must be given with wheel chocks. These can be found on the Stubble Master models attached on the front of both of the light boards, see Figure 3.2. Both chocks must be placed under one of the centre axle wheels to stop the machine from rolling. The machine should be lowered into its lowest position on the front skids to support the front of the machine correctly or supported via the fixed pin stand; see Figure 3.3.

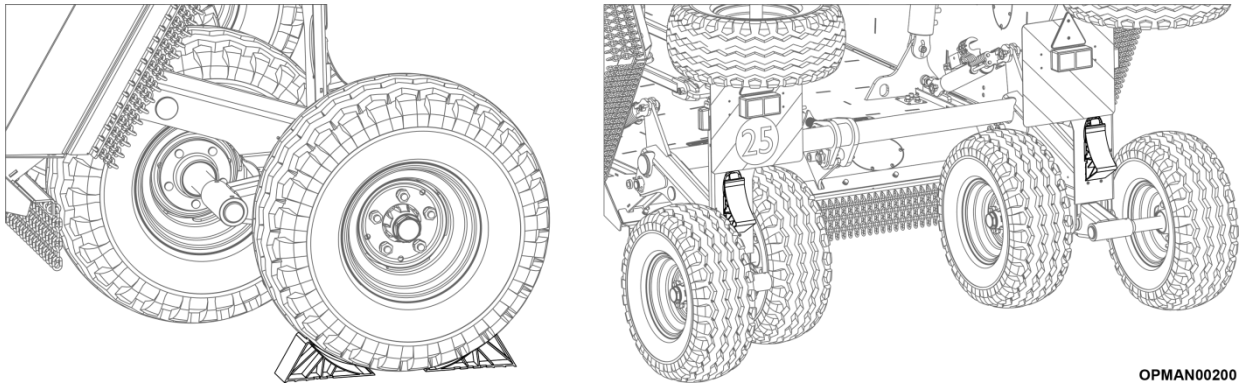

Figure 3.2 – Stubble Master Chock Storage & Positioning

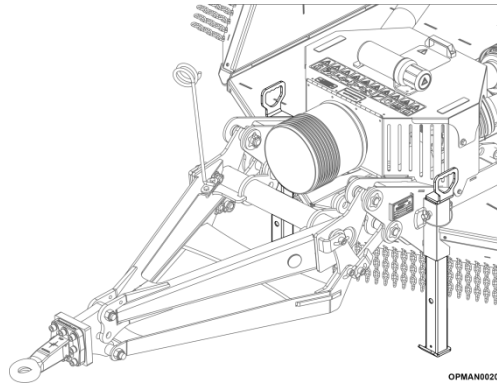

Figure 3.3 – Stubble Master Stand Positioning

3.2 Post-delivery/First Use Inspection

3.2.1 Tractor Inspection

It is important to read the tractor manufacturer's operators manual to ensure that a complete inspection to the manufacturer's recommendations is carried out on the tractor ensuring it is in correct working condition and has the correct safety measures in place for use. It is important before use to check the suitability of the tractor using the manufacturer's manual to ensure it meets the requirements to fit and operate correctly with the machine.

3.2.2 Machine Adjustment

The machine when received from Spearhead is virtually complete and components are set correctly, requiring minimum time to ready the machine for use. Spearhead machines are tested after manufacture.

It is important to assess the machine to ensure that it is of the correct specification ordered from Spearhead or local Spearhead dealer. Information with regards to the specification of the machine can be found on the machines serial plate. Guidance to the location of the serial plate can be found in Section 1.3.

Before use it is important to inspect the machine following the guidance in this operators manual to ensure it is correctly set-up and is suitable for the attaching tractor using the inspection guidance sheet in Section 5.10.

3.3 PTO Shaft

3.3.1 PTO Setup & Adjustment (first use)

	Equipment Required
	<ul style="list-style-type: none"> • Tape Measure • Marker Pen

The PTO of your machine will be delivered as it left the manufacturer, so will require to be shortened to give the correct effective length between the machine and the power take-off of the tractor.

In order to determine the correct length of the finished driveline, hook the machine to the tractor and proceed to install the two uncoupled/unprotected semi-shafts to their respective tractor/machine PTO's. For guidance on fitting input shafts; see Section 4.5.1.

Place the tractor/machine in the position so the two halves of the shafts are at the minimum distance between the two ends; see Figure 3.4. At this point, verify any interference of the outer tube with the yoke inner tube and establish how much the outer tube needs to be shortened.

On trailed machines, the minimum distance "Dmin" (see Figure 3.4), occurs between the joints during steering. Verify that in the condition of maximum extension "Dmax", which generally occurs when the machine is aligned going slowly downslope, the coupling between the two tubes is still sufficient.

The input shaft should be shortened to ensure:

- At least 25mm (1") clearance at the shortest point (Dmin) between the end of the shaft and the universal joint
- At least 1/3 of the shafts length overlap engagement at the longest point (Dmax) between the two CV tube halves

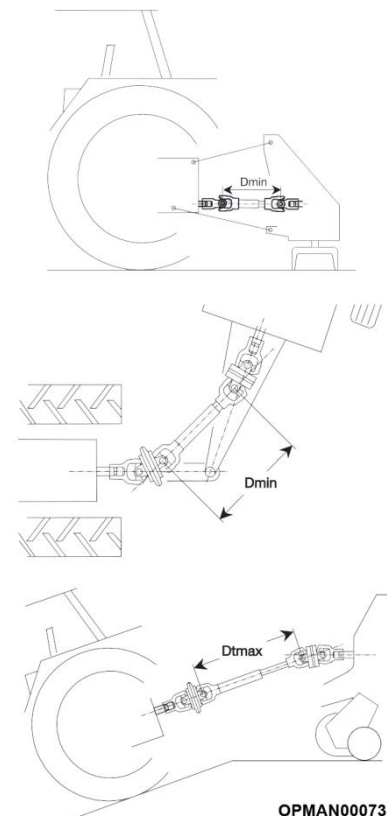



Figure 3.4 – Max/min Input Shaft Overlap

Check and ensure that the shaft has been sufficiently maintained and prepared before proceeding to use using the machine following the guidance given in Section 5.2.

3.3.2 Bottoming Out Test

	Equipment Required
	<ul style="list-style-type: none"> • Coloured tape • Tape measure • Marker pen or plastic scribe

It is important to test whether the shaft has been sufficiently shortened to protect against "bottoming out" by:

- 3.3.2.1 Disconnecting the input PTO shaft and fully compress the two halves of the shaft together
- 3.3.2.2 Placing a piece of coloured tape on the inner shield 5mm (3/16") away from the end of the outer shield
- 3.3.2.3 Reattach the PTO shaft between the tractor and machine
- 3.3.2.4 Slowly drive the tractor **without** the PTO shaft engaged and make the machine turn the tightest turn possible and follow the most severe terrain expected
- 3.3.2.5 If at **any** point the outer shield end becomes any closer than 50mm (2") away from the placed tape, then shorten the PTO shaft and then test again

To effectively shorten and modify the input shaft; see Section 3.3.4.

NOTE: When determining the minimum and maximum lengths and during subsequent verifications, it is important to bear in mind that ground subsidence may cause further reduction or increase in the distance between the PTO's.

3.3.3 Engagement Test

	<p>Equipment Required</p> <ul style="list-style-type: none"> • Coloured tape • Tape measure • Marker pen or plastic scriber
-----------------------------------------------------------------------------------	---------------------------------------------------------------------------------------------------------------------------------------------------------------------

It is important to test whether the shaft has been sufficiently shortened to make sure there is sufficient overlap and engagement between the CV tubes by:

- 3.3.3.1 With the input PTO shaft attached, place the tractor and machine in the tightest corner possible, Dmax (see Figure 3.4).
- 3.3.3.2 Place a piece of coloured tape on the inner shield 5mm (3/16") away from the end of the outer shield.
- 3.3.3.3 Disconnecting the input PTO shaft and split the two CV tube halves.
- 3.3.3.4 Measure the distance between the coloured tape and the end of the inner shield. This gives the amount of overlap between the CV tubes.
- 3.3.3.5 It is important that at least a 1/3 of the length of the inner shield is engaged with the outer shield. If it's too short then a new longer shaft should be fitted.

Please contact your local Spearhead dealer for guidance on purchasing a new/replacement input shaft.

To effectively shorten and modify the input shaft see Section 3.3.4.

NOTE: When determining the minimum and maximum lengths and during subsequent verifications, it is important to bear in mind that ground subsidence may cause further reduction or increase in the distance between the PTO's.

3.3.4 Modifying & Shortening The Input PTO Shaft

Bondioli & Pavesi, the manufacturer of the PTO shafts which comes with all Stubble Master machines **do not recommend** modifications to its products. This is further supported by Spearhead.

NOTE: Bondioli & Pavesi and Spearhead declines all responsibility for damage and/or injury caused by modifying **any** of the power take-off shafts on Stubble Master machines in any other way than described in this manual. **If you are unsure of the procedure**, or need additional assistance, please **contact your local Spearhead dealer, qualified service centre or Spearhead**.

	<p>Equipment Required</p> <ul style="list-style-type: none"> • Tape measure • Marker pen or plastic scriber • Hacksaw or angle grinder (with cutting disc) • Flat hand file or angle grinder (with sanding disc) • NLGI #2 Molybdenum Disulphide grease with paint brush/distributor
-------------------------------------------------------------------------------------	------------------------------------------------------------------------------------------------------------------------------------------------------------------------------------------------------------------------------------------------------------------------------------------------------------------------------------------------

Proceed as follows to shorten the input PTO shaft:

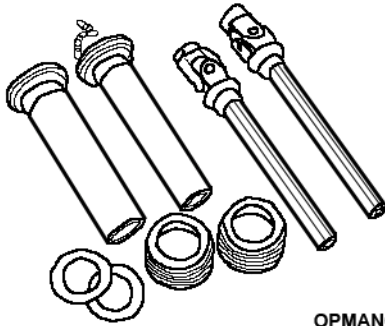

OPMAN00067
Figure 3.5

3.3.4.1 Remove shielding.

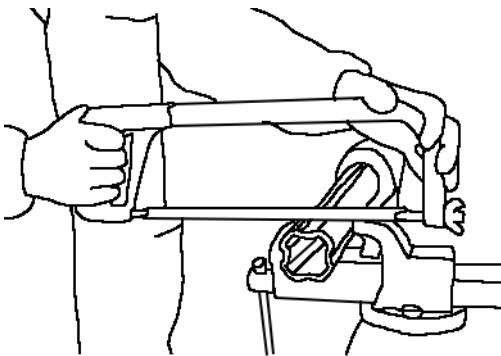

OPMAN00068
Figure 3.6

3.3.4.2 Shorten drive tubes by the required length. In normal conditions, telescopic tubes must always overlap **by at least a ½ of their length**. During manoeuvres, when the driveline is not rotating, the telescopic tubes must have a suitable overlap to maintain the tubes aligned and allow them to slide properly. See Section 3.3.3.

If the driveline has a single chain restraint system (splined inner tube), the tubes can be shortened by a limited amount (**normally no more than 70mm**) to avoid eliminating the splined ring connecting the two shield tubes.

If the driveline is fitted with a greasing system incorporated in the inner drive tubes, the tubes can be shortened by a limited amount to avoid damage to the lubrication system. Carefully measure and shorten each drive tube equally.

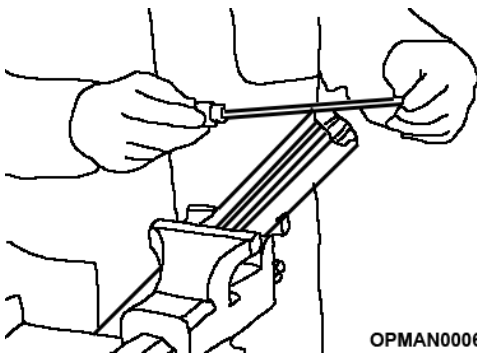

OPMAN00069
Figure 3.7

3.3.4.3 Carefully deburr the ends of the tubes with a file and remove any chippings from the tubes.

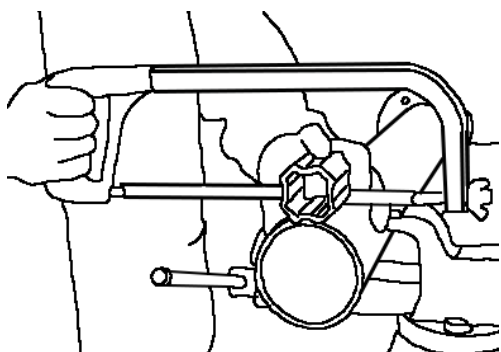

OPMAN00070
Figure 3.8

3.3.4.4 Shorten shield tubes one at a time by cutting the same length that was cut from the drive tubes. If the driveline is equipped with Single Chain Restraint System, shortening the driveline will involve removal of the plastic ring which connects the shield tubes. If it is necessary to remove this collar, add a retaining chain to the tractor side of the driveline shield.

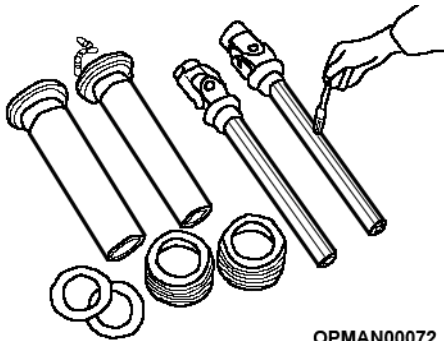

OPMAN00072
Figure 3.9

- 3.3.4.5 Grease the internal drive tube. Reassemble the shield on the driveshaft.

NOTE: SFT drivelines with 4-tooth profiles must be reinstalled in such a way that the grease fittings on the cross kit bearings are aligned.

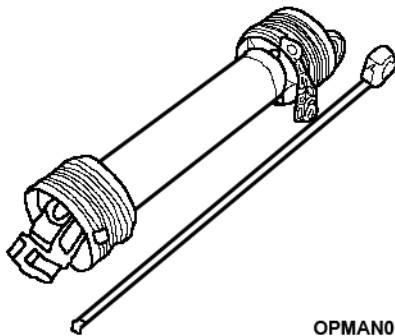

OPMAN00071
Figure 3.10

- 3.3.4.6 Check the length of the driveshaft at the minimum and maximum positions of the machine. See Figure 3.4 for guidance on Dmin/Dmax lengths.

If further adjustment is required; repeat the process.

3.3.5 Fitting The PTO Shaft

For guidance on fitting the Power Take Off (PTO) shaft between the machine and tractor; see Section 4.5

3.4 Wheels & Tyre Installation

There may be on some occasions, dependent on the type of delivery chosen for the machine to be delivered to the dealer/customer where wheels and tyres could be removed from the machine and will be required to be refitted to the machine when it arrives and before its first use. An example of this could be if the machine has been delivered inside a container.

For guidance on removing and installing tyres see Section 5.7.

4 Usage Instruction

4.1 Operator Requirements



IMPORTANT: Read, understand and follow the safety messages stated throughout this section and the rest of this operator's manual. Serious injury or death may occur unless care is taken to follow the warnings.

Safe operation of the Stubble Master machine is down to the responsibility of the qualified operator. A qualified operator has thoroughly read and understood the machine and attaching tractor operator's manuals and is experienced in the correct and safe operation of both machines and all associated safety guidance. In addition to the safety information contained in this manual, warning and operational decals are fixed around the machine; see Section 2.5.2. The connecting tractor will also have them as well with information given in the tractor operator's manual.

If any part of the operation safe use of the machine is not completely understood, consult a local Spearhead dealer or Spearhead for complete explanation.

If the operator cannot read the manuals for themselves or does not completely understand the operation of the equipment, it is the responsibility of the supervisor to read and explain the manuals, safety practices and operating instructions to the operator.

Personal Protection Equipment (PPE)

See Figure 4.1

- Always wear safety glasses
- Hard hat
- Steel toe safety footwear
- Gloves
- Hearing protection
- Close fitting clothing
- Respiration or filter mask (depending on working conditions)



Figure 4.1 - PPE Items



DANGER! Do not use drugs or alcohol immediately before or while operating the tractor and machine. Drugs and alcohol will affect an operator's alertness and concentration and ability to operate the collective machinery safely.

Before operating the tractor and machine, a machine operator on prescription or over-the-counter medication must consult a medical professional regarding any side effects of the medication that would hinder their ability to operate the equipment safely.

Supervisors must **never** allow anyone to operate the collective machinery when it is known that their alertness or coordination is impaired. Serious injury or death could occur to the operator and/or bystanders if the operator is under the influence of drugs or alcohol.



Figure 4.2 – Do Not Use Drugs Or Alcohol

4.2 Tractor Requirements

The tractor used to operate the machine must have sufficient capacity to lift, pull and operate the Power Take Off (PTO) at the machines rated speed (1000 rpm) while travelling at a working ground speed for the conditions and quantity of material of the work site. Operating the machine with a tractor which does not meet the requirements set by Spearhead may cause the tractor and/or machine damage, potentially risking danger to the operator and bystanders.

The working tractor **must** effectively offer the following characteristics to fit any of the Stubble Master machines.

Tractor Requirement (1)	Machine	
	Stubble Master 500	Stubble Master 730
Driver Protection	Approved cab (for country of use) with protective structure or Roll Over Protection Structure (ROPS) and seat belt. See local tractor standards (2)	
Safety Devices	Slow Moving (SMV) emblem, lighting, PTO master shield. See local tractor standards (3)	
Horsepower Requirement	120hp/89kW (4)	160HP/119kW (4)
Drawbar	Standard or K80 hitch to meet the requirements of Section 1.5.2.2	
Hydraulics	2 double acting hydraulic spool valves	
Front End Weights	Required in order to maintain the 20% weight required on the front axle (5)	
Power Take Off (PTO)	1000 RPM 1" 3/8 spline 6-spline, 8-spline or 21-spline; see Section 1.5.2.1	

Table 4.1 - Tractor Requirements and Capabilities

Notes:

- (1) Spearhead constantly reviews and improves product designs and reserve the right to change this information. Contact your Spearhead Sales representative if you have any queries.
- (2) The tractor must be fitted with a locally approved cab or Roll Over Protection Structure (ROPS) and have a seat belt to protect the operator from falling from the tractor or during a rolling over incident. Only operate the tractor when seated in the operator's seat with the seat belt securely fastened.
- (3) All guarding must be maintained to perfect working condition. Always replace shields and guards that were removed for access to service or repair the tractor or machine. Never operate machine/tractor without all safety devices in position.
- (4) Variations in power requirement can depend on the vegetation to be cut, terrain condition, operator experience and the physical condition of the machine and/or tractor. Running a machine on an overly large tractor may cause damage through overpowering the machine in heavy working conditions.
- (5) Front end weight is critical to maintain steering control and prevent the tractor from rearing up. Front weight and weight carriers can be purchased through an authorized tractor dealership.
- (6) Refer to the tractor owner's manual for instructions on how to change PTO speeds on models with more than one speed.

4.3 Connecting & Disconnecting Hydraulic Hoses & Electric Cables



CAUTION! Relieve hydraulic pressure before disconnecting lines or working on the system. This can be done by pushing and pulling/pushing the selected tractor lever/button. Only once this has been completed and suitable safety glasses and impenetrable gloves have been put on can the hydraulic hoses be removed from the tractor.

Connecting

With the tractor switched off and secured in position on level ground, relieve the hydraulic pressure from the tractor by moving the hydraulic control levers/buttons back and forth several times.

Stubble Master machines feature quick release hydraulic couplers and when connecting the hoses to the tractor it is important to keep the hoses, quick couplers and swivels free of contamination and dirt. If any component is deemed dirty ensure that it is cleaned with some clean rag before proceeding to fit the hoses. Never disconnect a hydraulic hoses and leave quick coupler end exposed. Utilise the coloured plastic caps supplied on the hoses

to keep them contaminant free. Ensure that the tractors hose ports are capped or clean before connecting the hydraulic hoses from the machine.

The electrical connections between the lights on the machine and the tractor should also be kept clean to ensure a reliable connection and reduce corrosion.

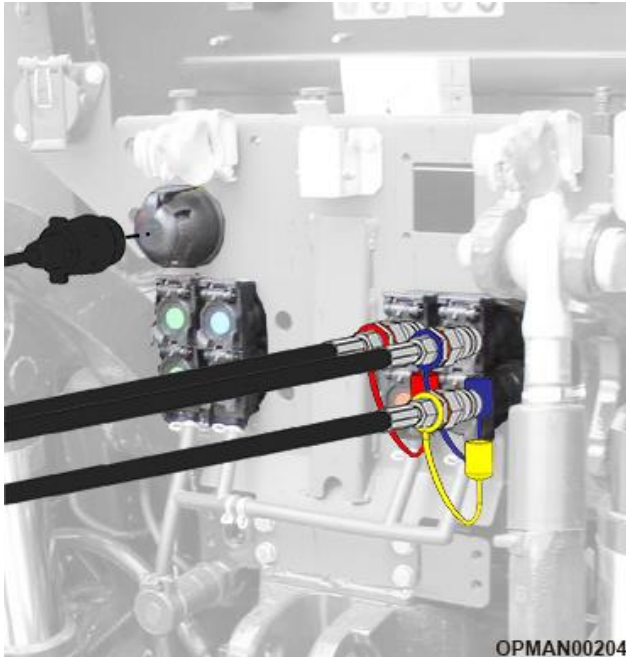

Figure 4.3
Stubble Master Hose & Light
Connections

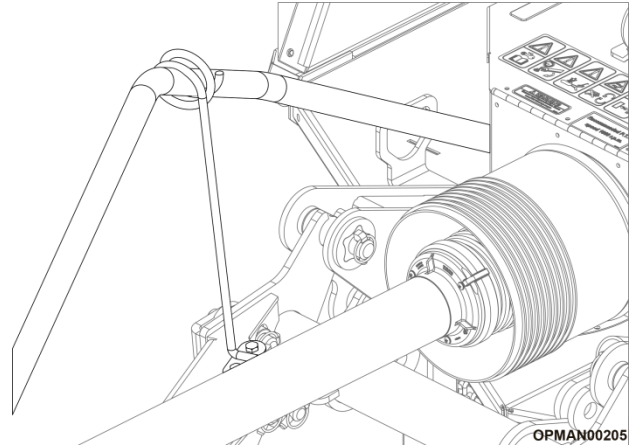

Figure 4.4
Stubble Master Drawbar Hose Guide

Ensuring that the quick couplers are clean; proceed to fit the hydraulic hoses. On all Stubble Master machines for visual reference **red hose cover caps relate to the wing lifting rams** and **blue and yellow hoses cover caps relate to the centre lift ram(s)**. Under the preference of the operator and which service they wish to use on the tractor, fit the wing lift ram hose into one bank of services on the tractor and the centre lift hoses into another; see Figure 4.3.

It is not critical as to which service the hoses are fitted to as long as it's from the same bank. Swapping the hoses over will cause the action in the tractor to be mirrored opposite; it is down to the preference of the operator in how they wish to operate the controls in the tractor. For all machines it is important to ensure that the hydraulic hoses are positively seated into the tractor.

Finally fit and fully seat the 7-pin machine electrical plug into the tractors socket.

IMPORTANT: Ensure that all the hydraulic hoses and the lighting cable are collated together and placed through the hydraulic hose guide on the machine; see Figure 4.4. This is to ensure that they do not touch the PTO shaft, bind when turning or get pinched/kinked in use.

For guidance as to the layout of the hydraulic hoses, see the full hydraulic hosing diagrams found in Section 5.6.5. It is important to state that Stubble Master wing rams are not independent and not able to be controlled independently.

With relation to Figure 4.3, there may be some variances in the layout of all of these items depending on the tractor manufacturer. Figure 4.3 is for visual reference only. Ensure that the operator fully understands the operations of the tractor before proceeding to use the machine by fully reading the tractor manufacturers operator manual.

Before proceeding to take the machine onto the road, ensure that all lights work.

Disconnecting

IMPORTANT: Depending on whether the machine is going to be left folded or unfolded, the machine should be secure so it doesn't move. If the machine is destined to be left folded ensure that the machine is safely secured with the ratchet strap to ensure that the wings do not drop when the hydraulic hoses are put into float or being disconnected. If the machine is destined to be left unfolded, ensure that the machine is lowered fully to the ground and is resting on the machine stands.

With the tractor switched off and secured in position on level ground, relieve the hydraulic pressure from the tractor by moving the hydraulic control levers/buttons back and forth several times.

Stubble Master machines feature quick release hydraulic couplers so they can be removed by first pushing in and then pulling out the connections. When disconnecting the hoses to the tractor it is important to keep the hoses, quick couplers and swivels free of contamination and dirt. Never disconnect a hydraulic hose and leave the quick coupler end exposed. Utilise the coloured plastic caps supplied on the hoses to keep them contaminant free. Ensure that the tractors hose ports are capped and clean before leaving the hydraulic hoses with the machine. If any component is deemed dirty ensure that it is cleaned with some clean rag.

The electrical connections between the lights on the machine and the tractor can be removed similarly by pulling on the connection. Like the hydraulic hoses, the electrical connections should be kept clean to ensure a reliable connection and reduced corrosion.

4.4 Hitching & Unhitching The Machine



DANGER! Always switch off the tractor completely, place the transmission in park, and set the parking brake before attempting to connect or disconnect the machine from the tractor.



WARNING! Only use clevis or K80 drawbar hitches for connecting to the machine. Hook hitches should not be used.

Spearhead claims no responsibility to damages to operator, personnel or machine by a hook hitch being used to trail.

4.4.1 Adjustable Pick-up Hitch

With tractors fitted with an adjustable pick-up hitch the machine can be rested on the skids and lifted by the means of the tractor to the desired height. Then proceed to fit the hydraulic hoses as shown in Section 4.3.

4.4.2 Fixed Pick-up Hitch

Hitching

On tractors without an adjustable pick-up hitch option, the machine will be required to be adjusted using the fixed stands with hydraulics to make the towing eye the same level as the hitch of the tractor. Measuring between machine and tractor will be required.

These sections of instructions are written on the assumption that the machine is being connected to the tractor whilst it is being held up by the machine stands.

- Centre axle lift rams have **all 10 spacers fitted** and the machine is lowered onto them.
- Wing axle lift rams have **no spacers fitted** and the rams are fully closed. (i.e. the machine is at its narrowest).
- The provided wheel chocks are in place so that the machine will not move when the hydraulics are adjusted; see Figure 3.2.

To adjust the machine to the correct height:

- 4.4.2.1 Ensuring that the machine stands are in their highest position, connect the hydraulic hoses of the machine to the tractor following the guidance given in Section 4.3.



WARNING! When filling the axle rams, the wing axle rams will extend and push the wheels outwards; see Figure 4.5.

It is **important** that the machine has sufficient free space, including vertically to ensure it doesn't come in contact with other objects e.g. another parked machine or roof/wall.

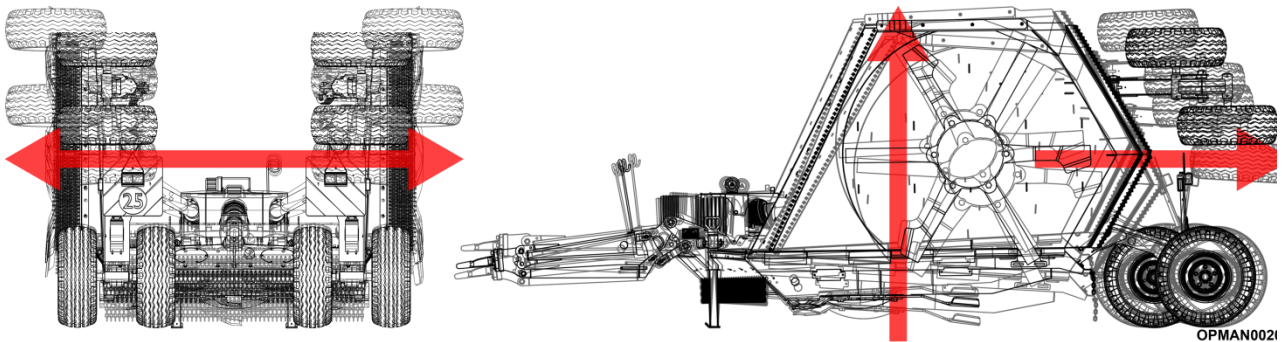

Figure 4.5
Stubble Master Wing Axle Movement Warning

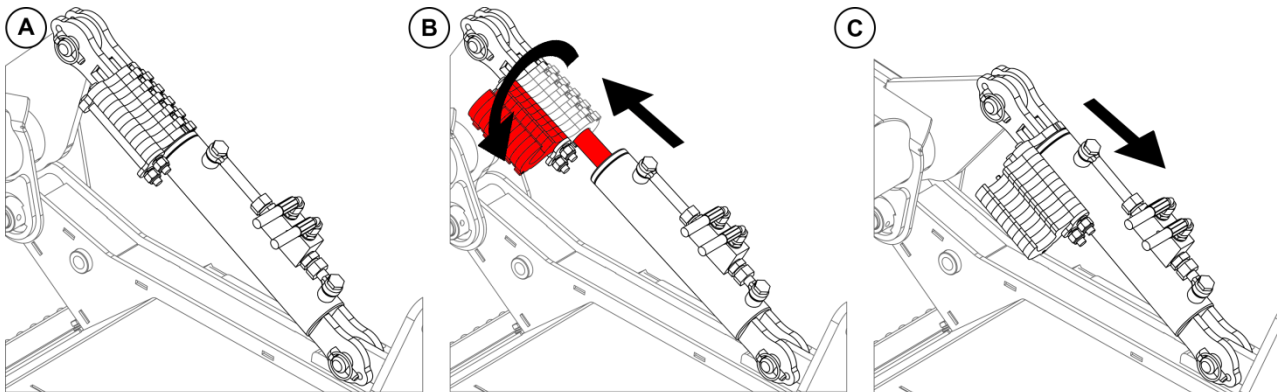

Figure 4.6
Stubble Master Centre Lift Ram Height Adjustment

- 4.4.2.2 Ensuring the hoses are seated properly, enter the tractor cab and use the tractors hydraulic control levers/buttons to completely fill the centre and wing axle lift ram cylinders with oil and raise the machine to create a clearance between the end of the ram and the spacer; see Figure 4.6 (B).
- 4.4.2.3 Switch off the tractor engine off and ensuring the tractor parking brake is engaged leave the driver's seat and proceed to remove all the ram spacers from both of the centre axle lift rams; see Figure 4.6 (B).
- 4.4.2.4 Adjust the height of the centre axle using the tractors hydraulic control levers/buttons until the same height is achieved between the towing eye and clevis hitch of the tractor; see Figure 4.7.

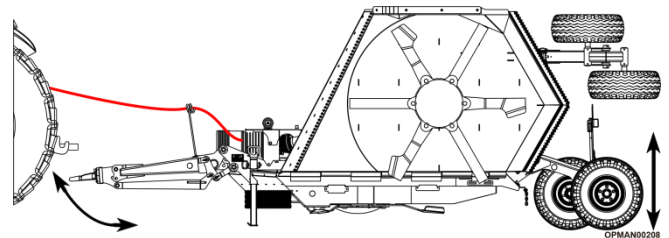

Figure 4.7 – Towing Eye Height Adjustment

- 4.4.2.5 Once the mulcher is at the same height as the tractor, carefully reverse the tractor to the mulcher and line up the towing eye with the clevis pin hole/K80 ball.

Make sure that there are no bystanders or other personnel in between tractor and machine during this process. Ensure that before leaving the tractor the engine is switched off and the handbrake is applied.

4.4.2.6 If the machine is fitted with either a standard or swivel towing eye, wear pads should be placed between the towing eye and the clevis hitch; see Figure 4.8.

Wear pads are supplied with the machine and should be periodically replaced when they become worn out to maximise longevity of the towing eye.

4.4.2.7 Install the towing pin and retaining lynch pin or K80 latch.

4.4.2.8 Fit the drawbar retention chain; see Section 4.4.3.

4.4.2.9 Raise the machine fully. Switch off the tractor engine off and ensuring the tractor parking brake is engaged leave the driver's seat and proceed to **fit all 10 ram spacers** into both of the centre axle lift rams; see Figure 4.6 (A).

4.4.2.10 Raise the machine stands and secure with the provided lynch pins.

4.4.2.11 Return back to the tractor and fully lower the machine on the centre axle ram spacers and continue to use tractor hydraulics until the wing axle rams/wheels have closed up fully (i.e the machine is at its narrowest).

Spearhead offers three different towing hitch options for Stubble Master machines; standard, swivel and K80.

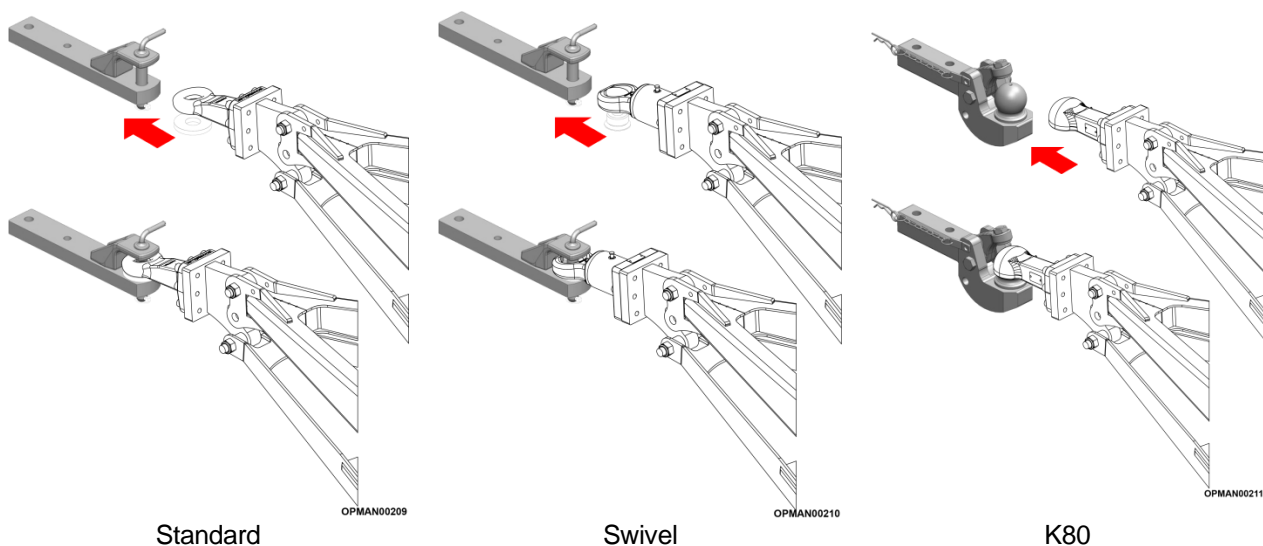
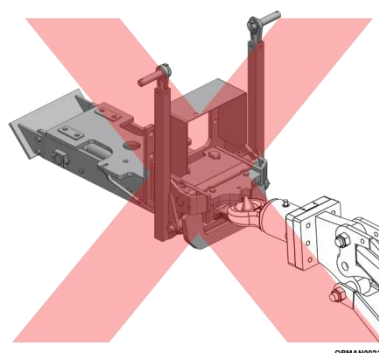

Figure 4.8 – Stubble Master Towing Eye Options



**Figure 4.9 – Do Not Use Tractor Pick Up Hitch!
(SWIVEL TOWING EYE ILLUSTRATED)**

Unhitching



DANGER! Always switch off the tractor completely, place the transmission in park, and set the parking brake before attempting to connect or disconnect the machine from the tractor

Unhitching the machine is a reverse operation of the hitching process stated in the previous section. Ensure that the input shaft has been removed following the guidance given in Section 4.5.1.

IMPORTANT: Unhitching and planning to store the machine should be carried out on a level and firm ground to prevent the machine from rolling away. If the machine is destined to be left folded ensure that the machine is safely secured with the ratchet strap to ensure that the wings do not drop. If the machine is destined to be left unfolded, ensure that the machine is lowered fully to the ground and is resting on the machine skids.

4.4.2.12 Remove the provided wheel chocks from the machine and chock the centre axle wheels. Both chocks must be placed under one of the centre axle wheels to stop the machine from rolling.

These can be found on the front of both of the light boards, see Figure 3.2.

4.4.2.13 For tractors fitted with a fixed pick-up hitch, adjust the centre deck height via the tractor hydraulics so the stand can be fixed at the correct height with the securing pin; see Figure 4.7.

For tractors fitted with an adjustable pick-up hitch, it is possible to lower the machine onto the front skid instead.

4.4.2.14 Following the guidance given in Section 4.3, remove the hydraulic hoses from the tractor.

4.4.2.15 Ensuring the tractor and machine will remain stationary, remove the towing eye pin from the drawbar and gently drive the tractor away.

4.4.2.16 Collect the towing eye wear pad and safely store it somewhere so it is available for next use of the machine.

4.4.2.17 Ensure that all hydraulic hoses quick-release coupling ends are capped and kept off the floor and the input shaft is resting on the plated bracket to ensure these items don't get damaged. If the machine is not destined to be used for an extended period, fully disconnect the input shaft and consider bringing it indoors to maintain its condition.

For extended guidance on how to safely store the machine; see Section 5.11.

4.4.3 Safety Towing Chain

Further safety precautions should be placed between the tractor and machine with the addition of the safety chain. This should be securely fastened to the carrying tractor in a secure, permanent location and looped through the machine drawbar as shown in Figure 4.10.

The safety chain is there as a precautionary safety measure to aid the controlling of the machine in case the towing eye becomes disconnected from the tractor drawbar.

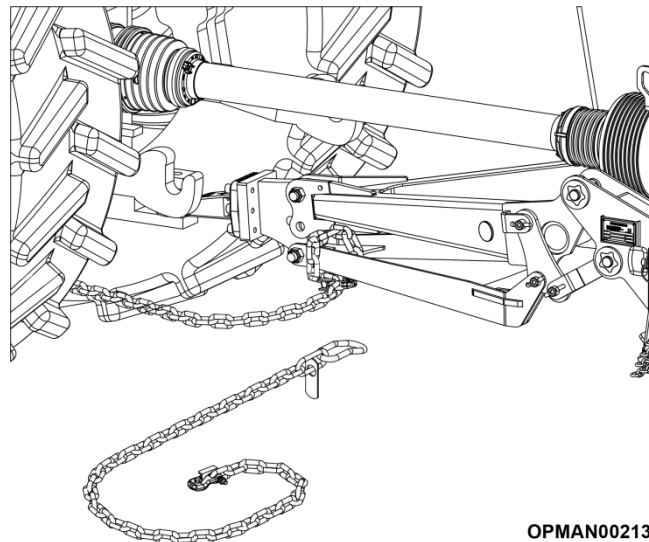

OPMAN00213

Figure 4.10 – Safety Towing Chain



DANGER! Never attach the mulcher to the tractor with a pin without a retaining lynch pin. Always ensure that the safety chain is securely fitted between the tractor and machine.

4.5 PTO Shaft



CAUTION! Many of the equipment components listed in this section used to carry out processes are heavy (25kg/60lbs+), and special lifting procedures are recommended to reduce potential user lifting injuries. Use mechanical lifting assistances, two people and other proper lifting techniques when connecting the input PTO shaft between the machine and tractor.

4.5.1 Fitting & Removal Of The Input PTO Shaft

Fitting

Make sure before proceeding to try to fit the input PTO shaft between the tractor and machine that the specification of the shaft is the correct speed, size and has the correct quantity of splines for the machine and the tractor can offer the machines required PTO speed.

Furthermore, ensure that it's been adjusted to the correct length for use between the machine and the given tractor as stated in Section 3.3.1.



DANGER! Do not use PTO adaptors to attach a non-matching implement driveline to a tractor PTO. Use of an adaptor can double the operating speed of the implement resulting in excessive vibration, thrown objects, blade/driveline failures due to changes in the machines design intended use. PTO adaptors also increase the exposed working length increasing the probability of entanglement with external objects. If the shaft is incorrect for the tractor; contact your local Spearhead dealer for assistance.



WARNING! When attaching the machine input shaft to the tractor power take-off, it is important that the connecting yoke spring activated locking collar slides freely and the locking balls are seated securely in the groove on the tractors output PTO shaft.

Push and pull the input shaft back and forth several times to ensure it is securely attached. An input shaft not attached correctly to the tractor PTO shaft could come loose and result in personal injury and damage to the machine.

Both the input shaft yoke and tractor PTO shaft must be dirt free and a light smearing of grease should be applied prior to attachment.

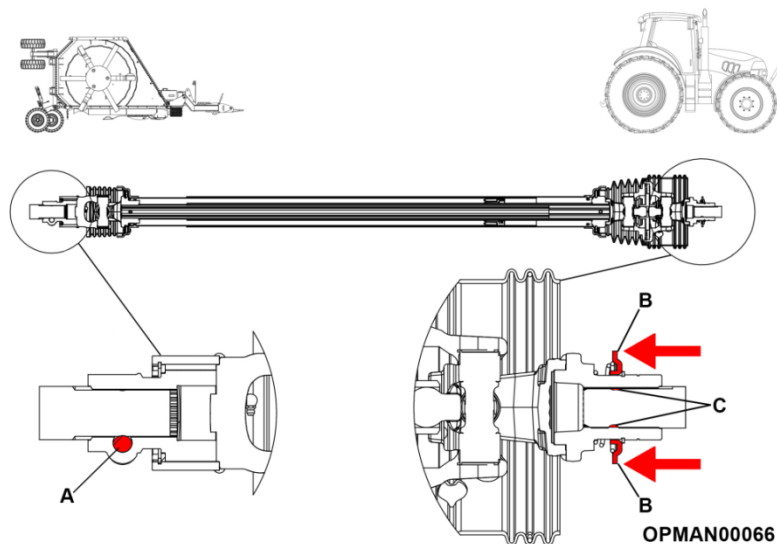

Figure 4.11 – Stubble Master Input Shaft Fitting & Removal

Fitting - Machine End



Equipment Required

- Torque wrench (see required settings in Torque Settings section)
- 22mm hex socket
- NLGI #2 Molybdenum Disulphide grease with paint brush/distributor

Proceed as follows:

- 4.5.1.1 Proceed to remove the taper pin, flat washer and nut from the machine end of the input PTO shaft. See Figure 4.11.
- 4.5.1.2 Install the input PTO shaft onto the splitter gearbox lining up the slot in the splitter gearbox shaft with where the input shaft taper pin will be placed; see Figure 4.11 (A). Replace the removed taper pin, flat washer and nut and tighten to a torque of 230Nm (170 ft/lbs).

It is best practice, when fitting the input shaft to wipe a small quantity of grease (NLGI #2 Molybdenum Disulphide) onto the splines to aid assembly and later removal.

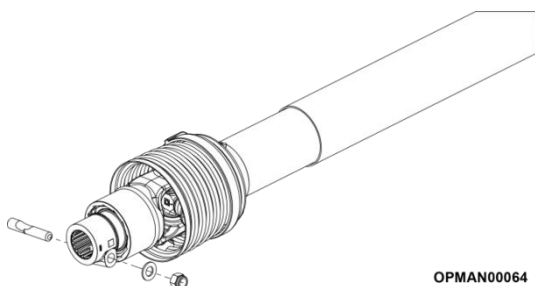

Figure 4.12 – Remove Taper Pin

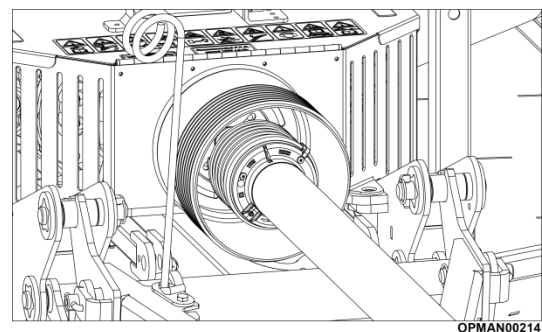

Figure 4.13 – Fit To Stubble Master

Fitting - Tractor End

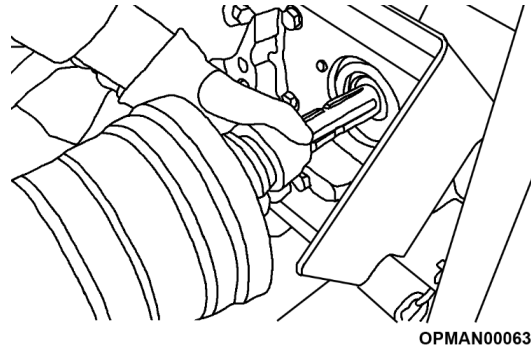

Figure 4.13 – Fit Input Shaft To Tractor

Proceed as follows:

- 4.5.1.3 Pull the input shaft yoke collar back and align the grooves and splines with those of the PTO output shaft of the tractor; see Figure 4.11 (B).
- 4.5.1.4 Push the driveline yoke onto the tractor output PTO shaft, release the locking collar and position the yoke of the input shaft until the locking collar balls are seated onto the tractors output PTO shaft; see Figure 4.11 (C).
- 4.5.1.5 To ensure that the input PTO shaft is secure, push and pull the shaft back and forth several times.

It is best practice, when fitting the input shaft to wipe a small quantity of grease (NLGI #2 Molybdenum Disulphide) onto the splines to aid assembly and later removal.

Removal



Equipment Required

- 22mm (M14) socket or spanner
- NLGI #2 Molybdenum Disulphide grease with paint brush/distributor

Removing the input shaft works in a reverse fashion from what is stated in the fitting section; by removing the shaft from the tractor end first. Ensure that the PTO is disengaged, tractor engine is stopped and the handbrake is applied before proceeding to remove the shaft.

It is best practice, when removing the input shaft, to wipe a small quantity of grease (NLGI #2 Molybdenum Disulphide) onto the splines of the exposed shaft end to prevent corrosion.

If the machine is not going to be used for an extended length of time the input shaft should be removed completely and stored indoors to maintain its condition.

Proceed as follows:

- 4.5.1.6 Pull the input shaft yoke collar back and pull back the shaft off the output splined shaft of the tractor; see Figure 4.11 (B).
- 4.5.1.7 If the shaft is not destined to be removed completely, utilise the machines PTO support bracket to rest the PTO shaft on; see Figure 4.15. This will ensure that the shaft doesn't get contaminated with dirt.

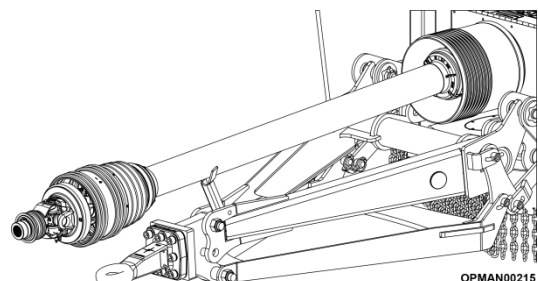

Figure 4.15 – PTO Support Bracket

- 4.5.1.8 To then completely remove the shaft, remove the taper pin, flat washer and nut from the machine end; see Figure 4.12.
- 4.5.1.9 Refit the removed taper pin, flat washer and nut for safe keeping.

- 4.5.1.10 It is best practice, when removing the input shaft to wipe a small quantity of grease (NLGI #2 Molybdenum Disulphide) onto the splines at each end to aid later refitting to the tractor.

4.5.2 PTO Shaft Specifications

Stubble Master machines are sold to operate at 1000 rpm.



DANGER! Do not use PTO adaptors to attach a non-matching implement driveline to a tractor PTO. Use of an adaptor can double the operating speed of the implement resulting in excessive vibration, thrown objects, blade/driveline failures due to changes in the machines design intended use. PTO adaptors also increase the exposed working length increasing the probability of entanglement with external objects. If the shaft is incorrect for the tractor; contact your local Spearhead dealer for assistance.

It is important to only operate at these speeds as a **maximum** and that the input PTO shaft is of the correct specification for the machine and tractor. See Table 4.2 for input shaft speed options and the spline quantity options.

Machine	PTO Speed	Number Of Splines
Stubble Master 500/730	1000 rpm	6
		8
		21

Table 4.2 – Input Shaft/PTO Speed Options

Stubble Master 500 machines feature a 2 plate slip clutch on each of the rotor gearboxes with an overrun on the input shaft.

Stubble Master 730 machines feature a combination of 2 and 4 plate slip clutches on each of the rotor gearboxes with an overrun on the input shaft.

NOTE: Some tractors offer the ability to change the PTO operating speed between 540/1000 RPM. Ensure that the correct PTO operating speed is selected for the machine. Refer to the tractor owner's manual for instructions on how to change PTO operating speed before proceeding to start the machine.

4.6 Unfolding & Folding The Machine

Unfolding

The machine when received from Spearhead is virtually complete and components are set correctly, requiring minimum time to ready the machine for use.



WARNING! When operating a fully assembled machine, do not release the ratchet securing strap until the hoses are attached to the tractor and each of the wing lift ram cylinders are filled with oil. Always ensure that bystanders are kept well away from the falling area of the wings.

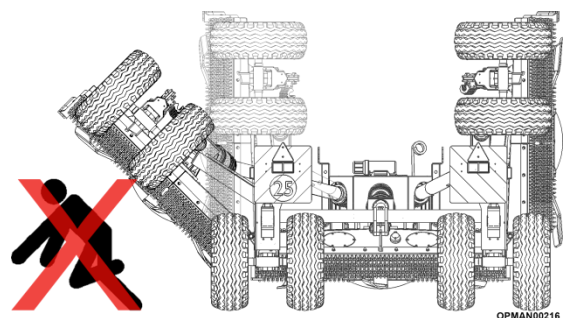

Figure 4.16 – Bystanders Under Wing

To lower the wings of the machine, connect the hydraulic hoses of the machine to the tractor; see Section 4.3. Once the hoses have been connected and seated properly, enter the tractor cab and use the tractors hydraulic control levers/buttons to completely fill the wing lift ram cylinders with oil. Leave the tractor once they're correctly filled.

Ensuring yourself and any bystanders/operator are kept well away from the falling area of the wing, proceed to the following:

- 4.6.1.1 Fully raise the centre axle of the machine off the ground using the tractors hydraulic control levers/buttons. Continue to hold the button/lever in order to fully extend the wing axle lift rams.
- 4.6.1.2 Remove the ratchet securing strap; see Figure 4.17.

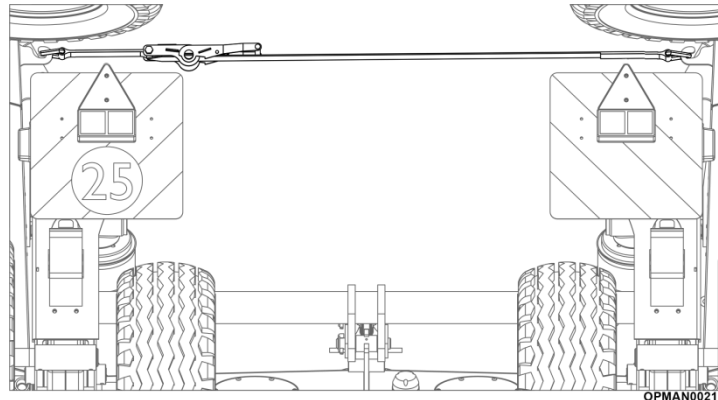

Figure 4.17
Stubble Master 500/730 Wing Retention Strap

- 4.6.1.3 Return to the tractor, ensuring the bystanders are still kept well away from the falling area of the wing use the tractors hydraulic control levers/buttons to release the wings to the ground.

All Stubble Master machines feature single-acting wing rams which utilise the weight of complete wings in order to lower themselves to the ground.
- 4.6.1.4 Remove all ram spacers from centre axle rams.
- 4.6.1.5 Raise and lower both wings, repeating the process several times to remove any potentially trapped air in the system. If the hydraulic system comes across as being "spongy" this could indicate air in the system. Continue to cycle the wings up and down until the sponginess has disappeared.



WARNING! If the machine wings fall down rapidly; have the cylinders and/or hoses checked/repaired/replaced before proceeding to use the machine again.

- 4.6.1.6 Set up the centre and wing ram spacers to give the correct required cutting height; see Section ??.

Folding

Folding the machine is carried out in a reverse fashion to the unfolding of the machine.

- 4.6.1.7 Fully raise the centre and wing axle rams of the machine off the ground and remove all wing axle ram spacers.
- 4.6.1.8 Fit the 10 ram spacers into both of the centre axle lift rams.
- 4.6.1.9 From the tractor seat, ensuring the bystanders are kept well away from the falling/raising area of the wing use the tractors hydraulic control levers/buttons to lift the wings off the ground.
- 4.6.1.10 Fit the ratchet securing strap; see Figure 4.17.
- 4.6.1.11 Use the tractors hydraulic control levers/buttons to close up the centre axle lift rams onto the spacers. Continue to hold the lever/button until the wing axle rams have also closed in completely, in order to make the machine as narrow as possible.

- 4.6.1.12 If the machine from now is not planned to be used, relieve hydraulic pressure before disconnecting the hydraulic hoses.

This can be done by pushing and pulling/pushing the selected tractor lever/button. Only once this has been completed and then suitable safety glasses and impenetrable gloves have been put on can the hydraulic hoses be removed from the tractor.

4.7 Setting Up The Machine

It is important to set the machine up properly front to back and with regards to its wings to ensure for safe operation and efficient working ability. A properly set up machine will give a more uniform cut, follow ground contours better and distribute its cut material more evenly out of the rear of the machine. It will also require reduced tractor work and effort from the operator.

Setting up the machine should always be carried out with the wings of the machine folded down. See Section 4.6 for the correct way to safely unfold the machine.

4.7.1 Front To Rear

	<p>Equipment Required</p> <ul style="list-style-type: none"> • Tape measure
-----------------------------------------------------------------------------------	---------------------------------------------------------------------------------------------------



WARNING! It is mandatory to switch the combustion engine off and disengage PTO and ensure that the tractor and machine is stopped, the ignition key is removed from the dashboard and the parking brake is engaged before leaving the driver's seat and proceeding to adjust the levelling of the machine.

Once coupled to the tractor, check the machine is cutting level from the front to the rear. Factory settings commonly change for shipping/transport and therefore will not give an even cut when operating for the first time.

Ensure that the machine has the correct towing eye option fitted for the tractor; see Section 1.5.2.2 for towing eye options.

To level the machine front to rear:

- 4.7.1.1 Place the machine on a level concrete surface, with the machine lowered onto its skids.
- 4.7.1.2 Measure from each end of the top of the hinge bar to the ground; see Figure 4.19 to determine the height of the front and rear of the machine.

IMPORTANT: Measurements need to be taken from the same side of the machine.

- 4.7.1.3 Loosen the locking nut; see Figure 4.20 (A).
- 4.7.1.4 Turn the barrel; see Figure 4.20 (B) anticlockwise to raise the front of the machine and clockwise to lower the front of the machine. The machine should be set at **12.5mm – 25mm (1/2" to 1") higher at the front of the machine to the rear.**
- 4.7.1.5 Once set at the correct height tighten the locking nut again; see Figure 4.20 (A).

IMPORTANT: Ensure that the machine tyre pressures are set correctly. See Section 5.7.1 for correct tyre pressures for the particular machine model and fitted tyre option.

NOTE: Keep in mind that the tyres may sink in soft conditions when the machine is in use altering the actual cut height; see Figure 4.21. As a safe precaution, set the cutting height slightly higher on set-up to cater for this sinking. Assess the working area after and then adjust again if required.

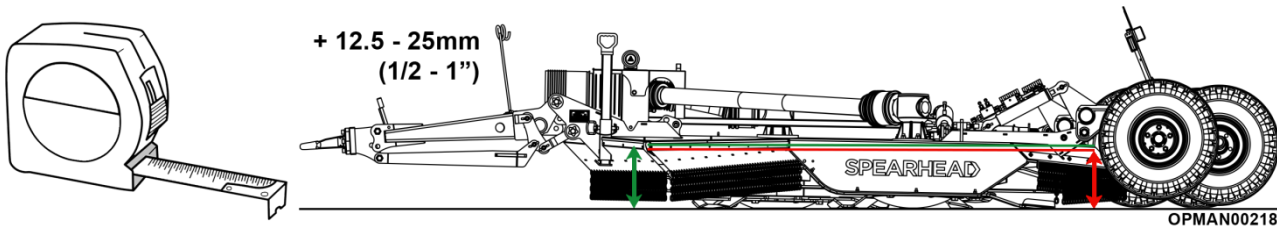

Figure 4.18 – Stubble Master 500/730 Front To Rear Machine Levelling
(Stubble Master 500 model shown)

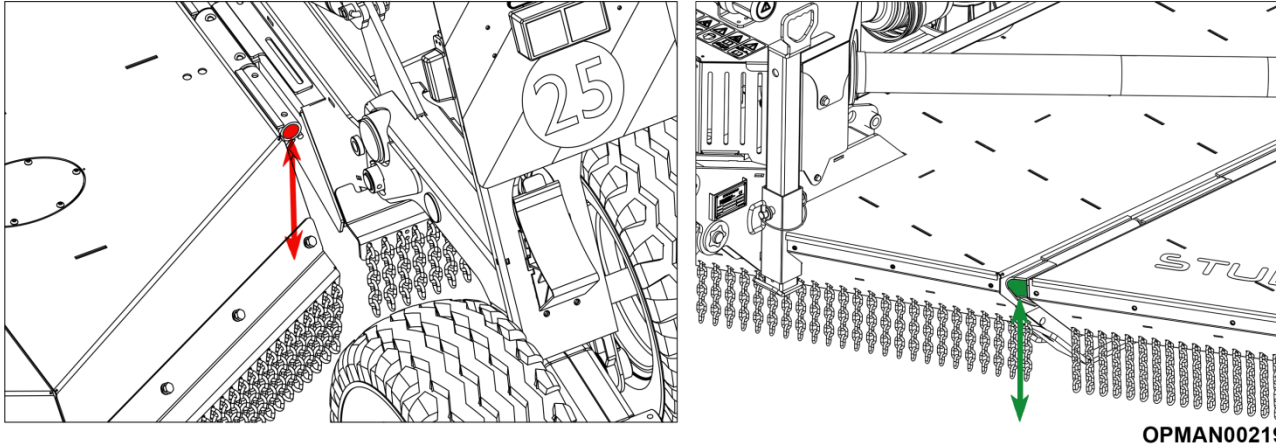

Figure 4.19 – Stubble Master 500/730 Front To Rear Machine Levelling
(Stubble Master 500 model shown)

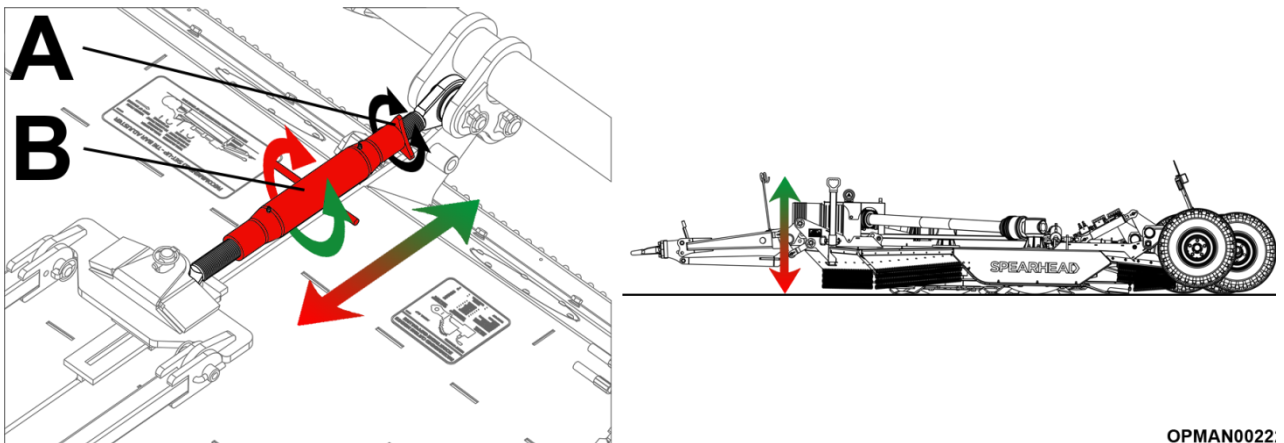
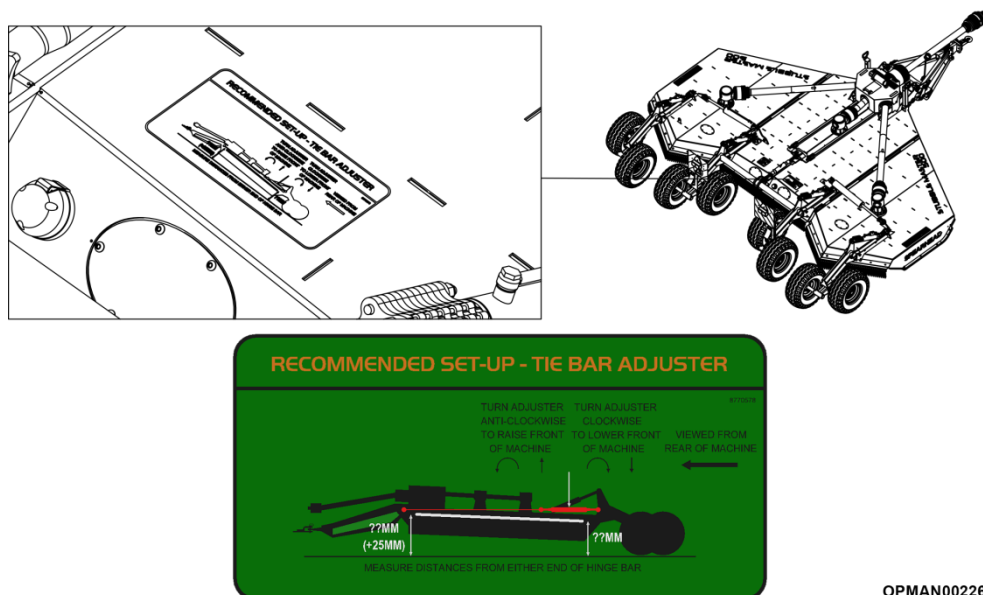

Figure 4.20 – Stubble Master 500/730 Front To Rear Machine Levelling
(Stubble Master 500 model shown)



Figure 4.21 – Tyre Sinking

Guidance to setting up the machine front to rear can be found in addition to this section on a decal found towards the rear of the centre deck of the machine; see Figure 4.22.



OPMAN00226

Figure 4.22 – Centre Deck Tie Bar Adjustment Decal & Location

4.7.2 Wings

Levelling the wings left to right is **most critical with low cutting heights** (75mm and below). Machines roll in work due to ground contours, soft ground supporting the wings and suspension give. It is advisable to prevent regular and excessive contact of the wing blades and anti-scalp dishes with the ground as this will cause them to wear more quickly. The additional load can also temporarily put excessive strain on the machine driveline leading to potential premature clutch wear and gearbox failures.

With the machine in the working position and the wings folded down it may be necessary to alter the height of the wing to ensure each rotor is cutting level.

We recommend the wings are set 12 – 25mm (½" – 1") higher than the centre chassis, to maintain a level cut; see Figure 4.23.

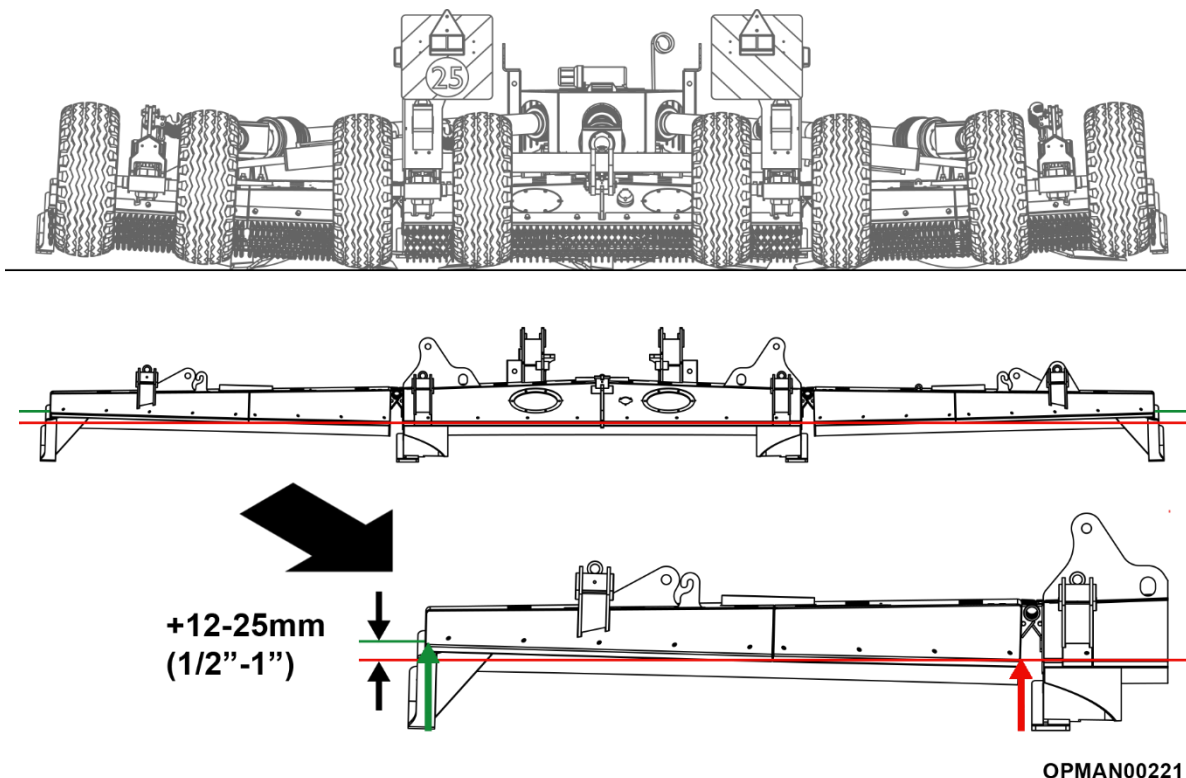

OPMAN00221

Figure 4.23 – Stubble Master Wing Height Adjustment
(Stubble Master 500 model shown)

	Equipment Required
	<ul style="list-style-type: none"> • Tape measure • 36mm hex spanner

IMPORTANT: It is important that the machine is set up correctly front to rear first before proceeding to set the wing height following the guidance given in Section 4.7.2.

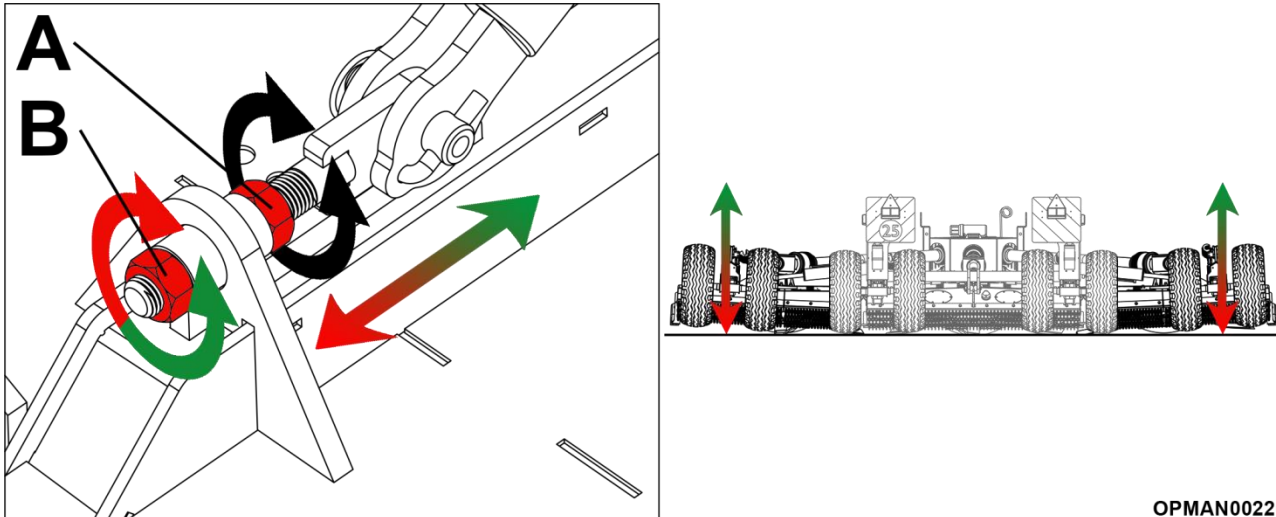

OPMAN0022

Figure 4.24 – Left To Right Machine Levelling Wing Axle Adjustment

(Stubble Master 500 model shown)

To level the machine left to right:

4.7.2.1 Place the machine on a level concrete surface, with the machine lowered onto its skids.

IMPORTANT: The machine must rest on its skids so the weight is removed from the drawbar

4.7.2.2 Measure from each end of the top of the chain guards on each wing to the ground; see Figure 4.23.

4.7.2.3 Loosen the locking nuts; see Figure 4.24 (A) on the wing.

4.7.2.4 Turn the adjustment nut, see Figure 4.24 (B) anticlockwise to raise the rear axle and clockwise to lower the rear axle. The machine should be set at 12.5mm – 25mm (1/2" to 1") higher at the outside of the wing to the inside.

Raising the axle will increase the height on the outside and lowering will decrease the height.

4.7.2.5 Once set at the correct height tighten the locking nuts again; see Figure 4.24 (A).

4.7.2.6 Repeat process on the opposite wing.

IMPORTANT: Ensure that the machine tyre pressures are set correctly. See Section 5.7.1 for correct tyre pressures for the particular fitted tyre option.

NOTE: Keep in mind that the tyres may sink in soft conditions when the machine is in use altering the actual cut height; see Figure 4.21. As a safe precaution, set the cutting height slightly higher on set-up to cater for this sinking. Assess the working area after and then adjust again if required.

4.8 Setting Cutting Height

IMPORTANT: This section is written on the provision that the machine has been set up correctly front to rear and with regards to its wings following the guidance given in Section 4.7.1 and 4.7.2.

To alter the minimum height of cut, fully raise the machine. Ensure that the PTO is disengaged, tractor engine is stopped and the handbrake is applied before proceeding to leave the tractor.

Proceed to the rear of the machine and insert or remove the correct quantity of ram spacer stops following the guidance given in Table 4.3. It is important that all rams are spaced equally to ensure a level cut.

Once the spacers have all been inserted across the whole width of the machine; the machine is ready for use.

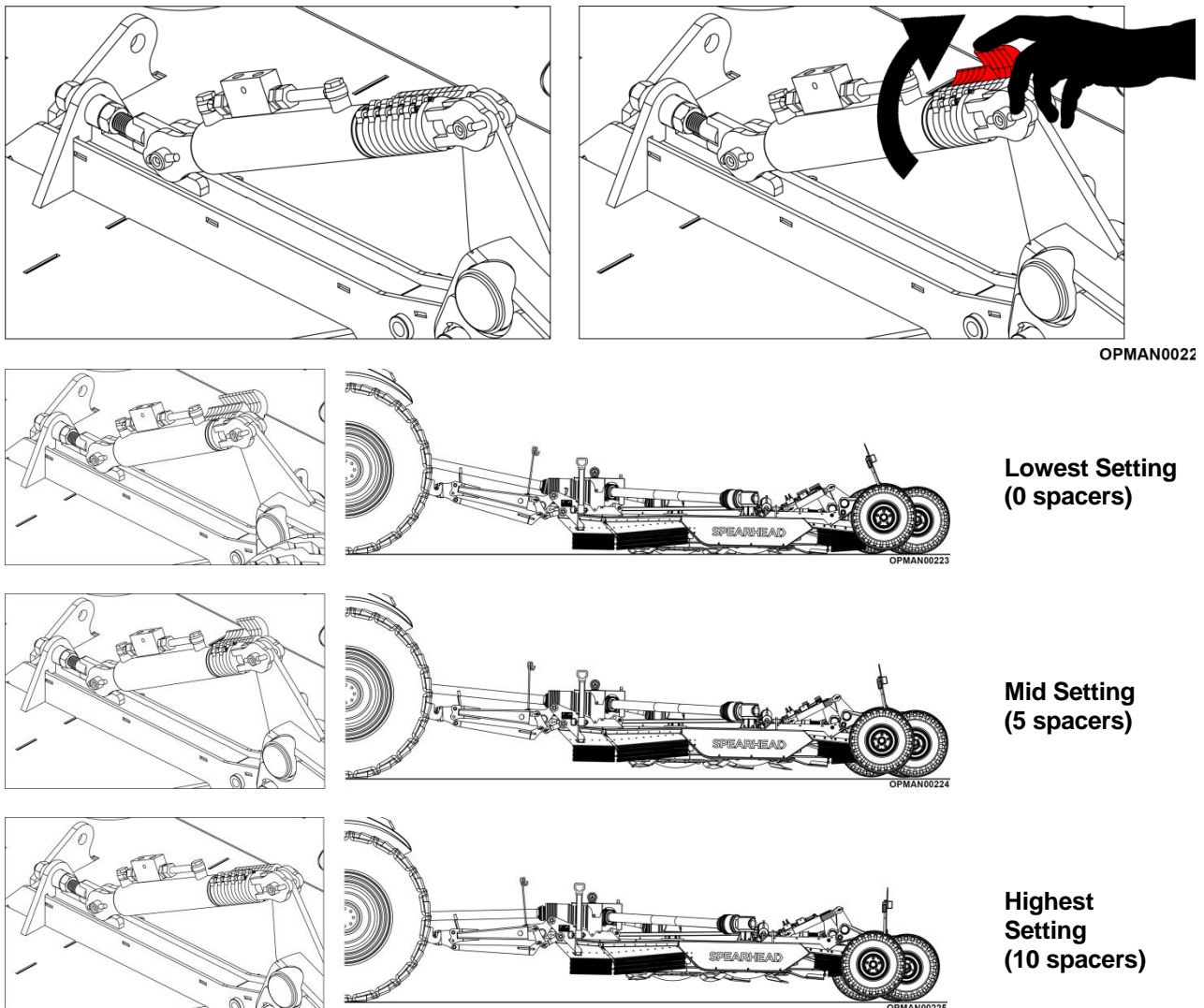

Figure 4.25 – Stubble Master Cutting Height Spacer Setting Visual

Table 4.3 shows a **reference** guide as to the minimum height of cut that will result.

This table of data is just for reference to create a ballpark figure for the customer to start from and assumes:

- Tyre pressures are correct
- Levelling is carried out on perfectly level and firm ground
- A brand new machine with no worn components
- The machine is perfectly set levelled front to rear as shown in Section 4.7.1
- The machine is perfectly set levelled left to right as shown in Section 4.7.2
- The machine is perfectly manufactured and there is no tolerance variation in components

Due to this Spearhead shows the data below as a reference holding no responsibility for the machine not achieving the **exact** quantities given in Table 4.3. It is important for the operator to try out the machine at the work site with the expectation that they will need to adjust the machine after to get exactly what they require to fit the working conditions.

Crop Type.	Cutting Height.	No. Of Spacers.
Cereals (Wheat, Barley e.t.c.)	80-100mm (3" - 4")	6-7
Oilseed Rape	60-80mm (2.5" - 3")	5-6
Maize (Silage)	40-60mm (1.5" - 2.5")	4-5
Maize (Corn)	50-100mm (2" - 4")	4-7
Grass	60-80mm (2.5" - 3")	6-7
Grass Seed	30/100mm (1.25"/4")	3/7

Table 4.3 – Stubble Master Cutting Height Spacer Setting Guidance

Table 4.4 gives guidance to the correct way to transport machines with the wings folded. Stubble Master machines should be set with all spacers placed in the centre axle lift rams to ensure the machine does not collide with any ground objects when it is being transported. All wing ram spacers should be removed from the wing axle lift rams prior to folding to make the machine as narrow as possible. See Section 4.6 for guidance to folding the machine.

Setting	Deck.	No. Of Spacers.
Transport	Centre	10
	Wing	0

Table 4.4 – Stubble Master Transport Height Spacer Setting Guidance

The guidance given in Tables 4.3 and 4.4 is further given on a decal found near the rear of the centre deck of the machine, giving guidance in how to set-up the machine correctly for the given crop material; see Figure 4.26.

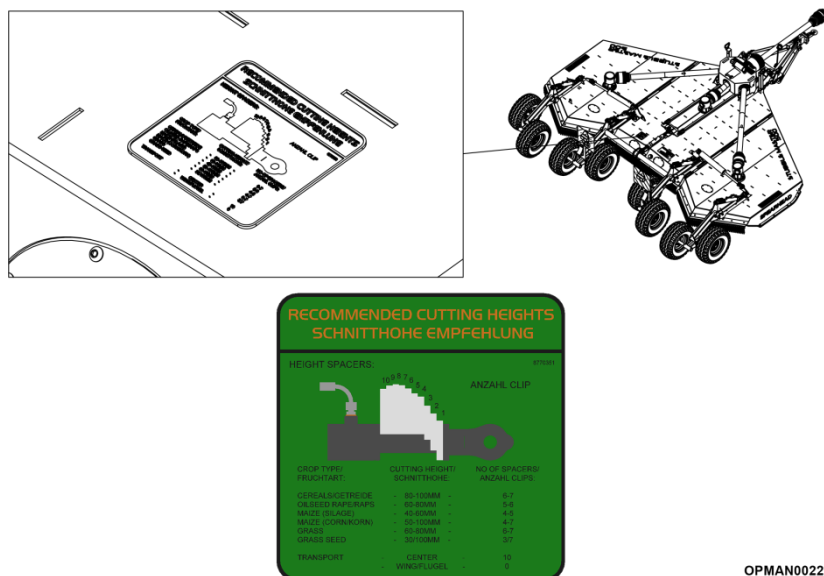

Figure 4.26 – Centre Deck Recommended Cutting Height Decal & Location

By using the machine for extended periods at very low cuttings heights will accelerate wear on blade components and cause greater strain on the machine drivelines and potential chance of failure.

4.9 Work Site Assessment

4.9.1 Foreign Debris Hazards

The destined work site to use the machine should be thoroughly checked and familiarised following the guidance given in Section 2.3.4 to assess the working area for hazards; removable and fixed.

Items should be assessed, removed or clearly marked (e.g. if too heavy to move) before mowing:

- Items and ground characteristics which could cause a reduction in the tractors stability and traction and operator safety and ease of control in operation
- Insufficient lighting
- Foreign objects which could be picked up and then flung by the machine damaging and causing risk to bystanders, operator, tractor or the nearby environment. Items seen on the surface and buried deeply in the material. For example rocks, tree stumps and manhole covers
- Foreign objects which could be picked up and then damage the machine; for example wire
- Low level objects which could come into collision with the tractor and/or machine
- Items which could create a fire risk

In overgrown areas which could potentially hide debris that could be struck by the blades, the area should be inspected and large debris removed, mowed at an intermediate height and then re-inspected closely with any remaining debris being removed. Then mow at the desired final height. This will also bring benefits to operations with reduced power requirements to mow, reduce wear and tear on the machine drivetrain, spread cut material better, reduce windrowing, and give a better overall finish.

Always wear your seat belt securely fastened and only operate the tractor and mulcher with the Roll-over Protection Structure (ROPS) in the raised position. If the tractor or mulcher hits a tree stump, rock, or bump, a sudden movement could throw you off of the seat and under the tractor and/or mulcher. The seat belt is your best protection from falling off the tractor and the ROPS provides protection from being crushed during a tractor roll-over.



OPMAN00170

Figure 4.27 – Inspect The Work Site

It is important to inspect the machine to ensure all mandatory fixed and removable guarding is in position and in correct working order before proceeding to use the machine. For guidance on the various guarding found on Stubble Master machines; see Section 2.6.



WARNING! Extreme care should be taken when operating near loose objects such as gravel, rocks, wire, and other debris. Inspect the area before mowing. Foreign objects should be removed from the site to prevent machine damage and/or bodily injury or even death. Any objects that cannot be removed must be clearly marked and carefully avoided by the operator. Stop mowing immediately if blades strike a foreign object.

IMPORTANT: Repair all damage and make certain rotor or blade carrier is balanced before resuming mowing.



WARNING! Many varied objects, such as wire, cable, rope, or chains, can become entangled in the cutting area of the mulcher deck. These items can swing outside the confines of the safe cutting area of the machine at greater velocities than the blades. Such a situation is extremely hazardous and could result in serious injury or even death. Inspect the cutting area for such objects before mowing. Remove any like object from the site. Never allow the cutting blades to contact such items.

4.9.2 Stopping The Machine In An Emergency



DANGER! If the machine hits an object, becomes jammed, suddenly develops vibration or any other potentially harmful change happens to the machine.

Stop the machine immediately!

If you hit a solid object or foreign debris:

- 4.9.2.1 Return the tractor to idle engine speed immediately.
- 4.9.2.2 Disengage the PTO.
- 4.9.2.3 Wait for all machine rotating parts to stop, then raise the mulcher and move the tractor and machine off the object.
- 4.9.2.4 With **extreme** caution, if a blocked foreign component has caused the machine to suddenly operate incorrectly or altogether ensure that all the correct levels of Personal Protection Equipment (PPE) is worn for safety purposes. **Consider gaining extra personnel** for assistance.
- 4.9.2.5 If the cause of sudden incorrect running of the machine is due to the machine colliding or hitting a foreign object, inspect the area and remove, or mark the location of the debris so it's not hit again.
- 4.9.2.6 Inspect the condition of the machine and make any needed repairs **before** proceeding to use the machine again. Make sure the blades are not damaged and the carrier is balanced before resuming operation.

4.9.3 Bystanders



DANGER! Machines are capable under adverse conditions of throwing objects for great distances 90m (300 ft) or more and causing serious injury or death. Follow safety messages carefully.

It is of utmost importance that the tractor and machine is stopped immediately if a bystander comes within 90m (300 ft) while operating. The engine should be idled and the PTO disengaged. Do not restart work until the bystander is well past the 90m (300 ft) and then reassessed that there aren't any other new bystanders inside the danger zone.

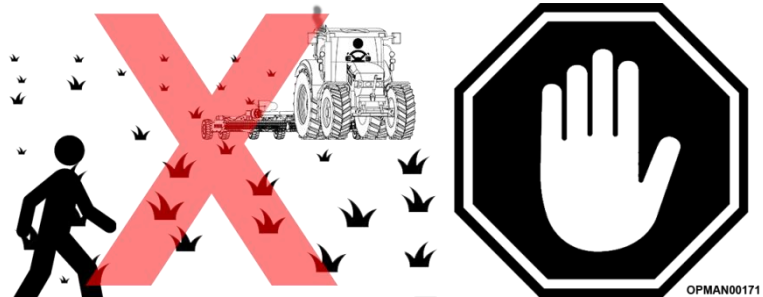

Figure 4.28 –Bystanders Out Of Working Area

It is of utmost importance to inspect the destined worksite before commencing work following the guidance given in Section 2.3.4 and Section 4.9.1.

4.9.4 Weather

Mow only in conditions where you have clear visibility in daylight or with adequate artificial lighting. Never mow in darkness or foggy conditions where you cannot clearly see **at least 90m (300 feet)** in front and to the sides of the tractor and mulcher. Make sure that you can clearly see and identify passersby, steep slopes, ditches, drop-offs, overhead obstructions, power lines, debris and foreign objects.

If you are unable to clearly see these type of items do not begin mowing.

4.9.5 Fire

Follow the following guidelines to reduce the risk of equipment and stubble fires while operating, servicing, and repairing the machine and tractor:

- Ensure the **tractor is equipped with a fire extinguisher** in an easy to access location
- **Do not** operate the machine on a tractor with an underframe exhaust
- **Do not** smoke or have an open flame near the machine and tractor
- **Do not** drive into burning debris or freshly burnt areas
- Ensure slip clutches are properly adjusted to prevent excessive slippage and plate heating. See Section 5.4.3 for clutch settings
- Never allow clippings or debris to collect near drivelines, slip clutches, and gearboxes
- Periodically shut down the tractor and machine and clean clippings and collected debris from the machine deck



Figure 4.29 – Beware Of Fire Hazards

4.10 Safe Driving Practices

In order to safely operate the machine in work with the tractor requires the operator to have a thorough knowledge and experience of the tractor they're using and safety precautions they should take whilst driving with the attached machine.

With regards to the tractor and the surrounding environment it is important that the operator can:

4.10.1.1 Ensure the tractor has been properly serviced and maintained. Do not operate the tractor with weak/faulty brakes or worn tyres.

4.10.1.2 Ensure the tractor has the capacity to handle the weight of the machine; see Section 1.5.1.

Failure to have at least 20% sufficient load over the front axle or to drive at inappropriate speeds on undulating terrain may result in a loss of directional control.

4.10.1.3 Ensure the tractor operating controls are set for safe transport. Consult the tractor manufacturers operators manual.



WARNING! Transport only at speeds where the machine and tractor can be maintained in control. Drive **conservatively**. Serious accidents and injuries can result from operating this equipment at high speeds.

4.10.1.4 Before using the tractor and machine ensure that the machine is only operated at safe speeds; on and off road (including work).



Figure 4.30 – Follow Safe Driving Practices



DANGER! Steering should be taken at slow speeds to maintain machine stability. Violently changing direction will greatly reduce machine stability resulting in loss of steering control, potentially turning over the machine and/or tractor causing serious injury, or even death

- 4.10.1.5 The operator should start at slow speeds and familiarise themselves of the operating and handling characteristics of the tractor in combination with the fitted machine off road before proceeding to drive the machine onto the public highway. Gentle steering and braking should be adhered to maintain control and overall stability
- 4.10.1.6 Tractor independent brakes should be locked together and the differential lock should be disengaged.
- 4.10.1.7 Before transporting the tractor and machine, determine the legal maximum transport speeds for the equipment conforming to local jurisdictions and comfortable transport speeds for the operator. Only increase speeds safely when conditions allow or the operator is comfortable to do so.

Transport the machine only at safe speeds which allow you to properly control the machine and at a **maximum** speed of 20 mph (32 kph). Drive for the conditions and reduce speed if required. Increasing speeds, operating down a hill or on wet or rain slick roads; increases stopping distances.

- 4.10.1.8 Make certain that the local jurisdiction legal safety requirement items are fitted. For example a “Slow Moving Vehicle” (SMV) sign is installed and tractor flashing warning lights. Check the local jurisdiction to determine whether the flashing warning beacons are required to be switched on when the machine is working.

Make sure all these safety awareness items are clearly visible and legible and follow all local traffic regulations. If the item is in anyway not working correctly or is faded; replace.



DANGER! The machine may be taller and wider than the tractor. Be careful when operating or transporting the machine to prevent the machine from running into or striking sign posts, barriers, walls, cars or any other solid objects. Such an impact could cause the tractor and/or machine to violently change direction or balance resulting in loss of steering control, serious injury, or even death.

- 4.10.1.9 Be aware of other road users and bystanders and make the machine aware to other users. Check your side view mirrors frequently and remember vehicles will approach quickly because of the tractor's slower speed. Gain eye contact with other people to gauge they've seen the tractors presence.
- 4.10.1.10 When operating on public roads, have consideration for other road users. Pull to the side of the road occasionally to allow all following traffic to pass. Do not exceed the legal speed limit set in your local jurisdiction for agricultural tractors. Always stay alert when transporting the tractor and machine on public roads. Use caution and reduce speed if other vehicles or pedestrians are in the area.
- 4.10.1.11 Make sure all tractor and machine lighting are functioning correctly. Older tractors may not feature as many/bright lights as modern tractors. Consider upgrading the lights by consulting your authorized tractor dealer to ensure that the tractor and machine presence is seen.
- 4.10.1.12 Be extremely cautious when the piece of equipment that is being towed is wider than the tractor tire width and/or extends beyond the lane of the road.
- 4.10.1.13 It is of utmost importance that safety decals are kept clean and replaced if they are no longer legible, damaged or lost completely. Safety decals can be purchased readily from a local Spearhead dealer.

4.11 Using The Machine

4.11.1 Engaging The Power Take-off (PTO)

Only operate the machine from the tractor operator's seat with the seatbelt securely fastened. The tractor must be equipped with a ROPS cab.



WARNING! Do not let the blades turn when the decks are raised for any reason; including clearance or for turning. Raising the mulcher deck exposes the cutting blades which creates a potentially serious hazard and could cause serious injury or even death from objects thrown from the blades.



WARNING! Do not put hands or feet under mulcher decks. Blade contact can result in serious injury or even death. Stay away until all motion has stopped and the decks are securely blocked up.

Before engaging the PTO, make certain that the area is clear of bystanders and passersby. The machine must be completely lowered to its desired cutting position. **Never** engage the PTO with the implement in the raised position.

4.11.1.1 Set the tractor engine speed at approximately 1,000 RPM before engaging the PTO.

4.11.1.2 Shift/press the PTO control to the on position.

4.11.1.3 Slowly increase the engine speed until the PTO is operating at the rated speed.

IMPORTANT: If you hear unusual noises or see or feel abnormal vibrations, disengage the PTO immediately. Inspect the implement to determine the cause of the noise or vibration and repair the abnormality before proceeding to use the machine.

4.11.2 Disengaging the Power Take-off (PTO)

To shut down the machine:

4.11.2.1 First bring the tractor to a complete stop.

4.11.2.2 Decrease engine RPM to idle then disengage the PTO.

The machine will come to a complete stop within a suitable amount of time.

IMPORTANT: Do not engage or disengage the machine at a high RPM unless there is an emergency situation.

Park the tractor on a level surface, place the transmission in park or neutral and apply the parking brake, lower the machine to the ground, shut down the engine, remove the key, and wait for all motion to come to a complete stop before exiting the tractor.

4.11.3 Forward & Power Take-off Speed

Once the power take-off has been engaged following the guidance given in Section 4.11.1, start off driving at a slow speed and gradually increase while maintaining complete control of the tractor.

Moving slowly at first will prevent the tractor from rearing up and loss of steering control. The tractor should never be operated at speeds that cannot be safely handled or which will prevent the operator from stopping quickly during an emergency. If the power steering or engine ceases operating, stop the tractor immediately as the tractor will be difficult to control.

Spearhead flex wing machines are designed to cut vegetation up to 100mm (4") diameter. Sharp blades will produce a cleaner cut and require less power. Travel at a speed that allows the mulcher sufficient time to cut through the vegetation and maintain the PTO operating speed to prevent overloading the mulcher and tractor. Choose a driving pattern that gives maximum pass length and least turning.

Speed for mowing will dependent upon the height, type, and density of the material to be cut. Recommended speed for efficient mulching performance is between 2 and 5 mph (3-8 kmh). Operate the machine at its full rated PTO speed (1000 rpm), to maintain blade speed for a clean cut. See the splitter gearbox guard for a guidance decal on the rated required operating speed for the machine.



Figure 4.31 – Tractor Driving Guidance

Refer to the tractor operator's manual or the tractor instrument panel for the engine speed and gear to provide the required PTO and desired ground speed. Make sure that the machine is operating at its full rated speed before entering the vegetation to be cut. If it becomes necessary to temporarily regulate engine speed, increase or decrease the throttle gradually.



WARNING! Do not exceed the rated PTO speed for the machine. Excessive PTO speed can cause driveline or blade failures resulting in serious injury or death. See the machine splitter gearbox guard for guidance on the correct operating PTO speed for the machine.

Forward speed is achieved by transmission gear selection and not by the engine operating speed. The operator may be required to experiment with several gear range combinations to determine the best gear and range which provides the most ideal performance from the mulcher and most efficient tractor operation. As the severity of cutting conditions increase, the ground speed should be decreased by selecting a lower gear to maintain the proper operating PTO speed.

Under certain conditions, tractor tires may flatten some stubble down preventing them from being cut at the same height as the rest of the width of the cutting area. When this occurs, reduce the tractor ground speed while maintaining the operating speed of the PTO. A slower ground speed will permit stubble to partially rebound and be cut. Taking a partial cut may also help produce a cleaner cut.



WARNING! Never use any Stubble Master machine in reverse direction. Seek alternate methods of cutting if a desired area cannot be accessed with the machine and tractor.



WARNING! Do not mow with two machines in the same area except with cabbed tractors with the windows closed.

4.11.4 Cornering

Drive the tractor with the 3-Point lift arms in the raised position and place the tractor PTO selector lever into neutral in order to protect the mulcher driveline and drawbar when turning.

Perform turns with the tractor and mulcher at slow speeds to determine how the tractor handles with the attached mulcher. Determine the safe speed to maintain proper control of the tractor when making turns. When turning with a towed implement, the overall working length of the unit is increased. Allow additional clearance for the mulcher when turning.

To avoid overturns, drive the tractor with care and at safe speeds, especially when operating over rough ground, crossing ditches or slopes, and turning corners.

Use extreme caution when operating on steep slopes. Keep the tractor in a low gear when going downhill. **Do not** coast or free-wheel downhill.

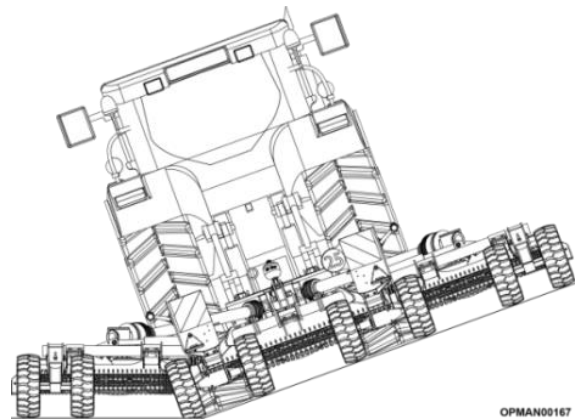

OPMAN00167

Figure 4.32 – Tractor Stability

When reaching the end of the cutting path; raise the machine before turning. **Never** raise the mulcher wings while the blades are turning.

When turning, reduce the tractor engine RPM to around 50% of the usual working RPM when cutting with the machine. Remaining at working RPM can cause premature wear on the input shaft and place pressure on the tractor PTO shaft and could cause extensive mechanical damage to the machine and tractor.

4.11.5 Crossing Ditches & Steep Inclines



WARNING! Damage resulting from bottoming out the input shaft inner profile and its outer housing may allow the input shaft to come loose from the tractor which could cause bodily injury to the operator or bystanders and/or extensive damage to the tractor or machine.

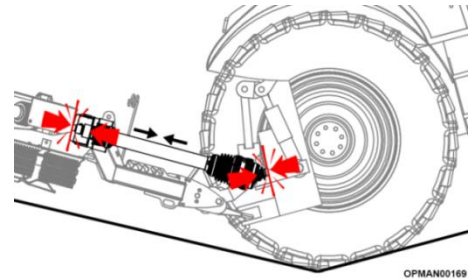
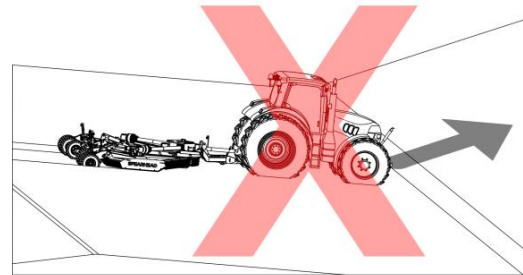

Figure 4.33 – Beware Of Bottoming Input Shaft

When crossing ditches with steep banks or going up sharp inclines, it is possible that the two halves of the input PTO shaft can become excessively overlapped so much that it will bottom out. This type of operation is deemed abusive and can cause serious damage to the tractor and machine drivelines by pushing the PTO into the tractor and through the support bearings or downward onto the PTO shaft, breaking it off, tractor or mulcher end.



When confronted with an incline or ditch, **do not approach from an angle which is perpendicular or straight on** as damaged to over collapse of the driveline may occur. When crossing such terrain, the implement should be fully lowered for a lower centre of gravity and added stability.

Inclines and ditches **should be approached along a line which is at an angle** as shown in Figure 4.34. This type of path will reduce the possibility of bottoming out the driveline and resulting in damage to machine and/or tractor. If the gradient is so steep that such an approach increases the possibility of a tractor roll-over, select an alternate crossing path.

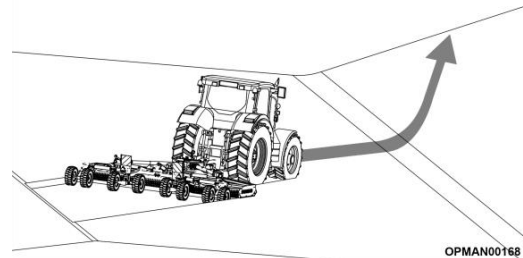

Figure 4.34 – Approach Ditches At An Angle

When operating the tractor and machine across slopes and inclines, through ditches, and other uneven terrain conditions, it is important to maintain sufficient deck to ground clearance. Blade contact with the ground may cause soil, rocks and other debris to be thrown out from under the mulcher resulting in possible injury and/or property damage. Ground contact also produces a severe shock load on the mulcher drive and to the mulcher blades resulting in possible damage and premature wear.

4.11.6 Un-level Ground

When mowing across uneven areas such as road shoulders, ditch edges, and other uneven terrain, position the mulcher so that one support wheel is near the highest point to prevent blades from cutting into gravel or dirt; see Figure 4.35. Contact with the ground will cause accelerated wear on the machine blades and/or blade carrier and cause severe shock loads on the machine driveline resulting in premature damage to these components. Blades contacting the ground may cause objects to be thrown out from under the mulcher deck. Always avoid operating the mulcher at a height or position which may cause the blades to contact the ground. Cutting into the berm or edge of the ditch will cause abnormal and accelerated blade wear and possible blade component failure.

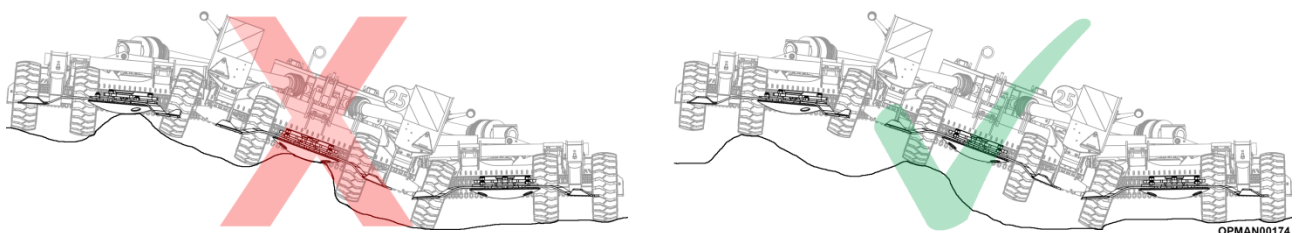

Figure 4.35 – Uneven Ground, Ride On The Tyres Not The Blade Carrier

4.12 Road Transporting The Machine

IMPORTANT: Fully read and understand Section 4.10 with regards to safe driving practice.

Fold the machine, following the guidance given in Section 4.6.

IMPORTANT: Ensure that the ratchet strap is fitted to ensure that the wings do not drop when being transported.



DANGER! When the wings are folded for transport, the centre of gravity is raised and possibility of overturning is increased. Drive slowly and use extreme caution when turning on hillsides. Overturning the machine could result in the tractor and/or machine turning over resulting in serious injury or death. Never fold machine wings on un-level surfaces.

Raise the centre lift ram to raise the machine sufficiently off the ground in order to give ground clearance over road obstacles, yet low enough to maintain on road stability.

Spearhead recommends setting the machine up with all **10 spacers placed in the centre lift rams and no spacers in both of the wing axle lift rams**; see Table 4.4. This is to ensure that the machine will **clear obstacles below the blade carrier** to its best ability as well as being as **narrow as possible when transporting on the road**.

Make sure that the safety tow chain is secured between the tractor and the machine before entering a public road.

When the machine is folded, the tractor rear lights may be obscured by the folded machine (depending on the tractor). Ensure the 7 pin plug is fitted into the rear of the tractor to ensure that all brake lights and turning signals work correctly on the machine.



Figure 4.36 – Follow Safe Driving Practices



WARNING! Only tow the machine behind a properly sized and equipped tractor which exceeds the weight of the machine by at least 20%; see machine weights in Section 1.5.1.

Never tow the machine behind a truck or other type of vehicle. **Never** tow two machines behind each other in tandem. **Never** tow the machine at speeds over 20 mph (32 kmh).



DANGER! Never allow children or other persons to ride on the tractor or machine. Falling off can result in serious injury or death.

4.13 Transporting The Machine On A Trailer

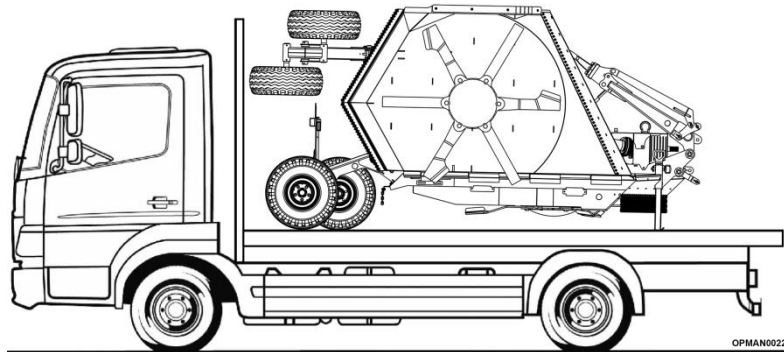

Figure 4.41 – Transporting Machine On A Trailer

Before transporting a machine (potentially plus tractor), measure the height and width dimensions and gross weight of the complete loaded unit. Ensure that the load will be in compliance with the legal limits set for the areas that will be travelled through during transit.

Use adequately sized and rated trailers and equipment to transport the tractor and machine. Consult an authorized dealer to determine the proper equipment required. Using adequately sized chains, heavy duty straps, cables and/or binders, securely tie down both the front and rear of the machine.

Arrange the straps so that when tightened, the straps are pulling downward and against themselves. Carefully tighten the securing strap or other fasteners to apply maximum tension and to ensure that no machine components get damaged. Use extreme care when attaching and removing the securing devices as the extreme tension involved when released has the potential to inflict serious injury.

While hauling the tractor and implement, make occasional stops to check that the machine has not moved or shifted and that the securing devices have maintained tension. If during transport a hard braking, sharp turning or swerving action was performed, stop at the next safe location to inspect the security of the load.

(This page is left blank intentionally)

5 Maintenance



WARNING! Before proceeding to carry out any maintenance on the Stubble Master machine, ensure that you have **thoroughly** read and understand Section 2.4 “Safe Maintenance” with regards to the correct and safe maintenance procedures of looking after the machine. This section gives safe guidance to ensure the wellbeing on the maintenance personnel as well as the machine itself.

5.1 Periodic Maintenance

Perform service, repairs, lubrication and maintenance procedures outlined throughout Section 5 to ensure the longevity and reliability of the Stubble Master machine.

In general:

- 5.1.1.1 Inspect for loose or missing fasteners, worn or broken parts, leaky or loose fittings, worn bushes and any other moving parts which are worn or missing.
- 5.1.1.2 Replace any worn or broken parts with genuine Spearhead parts under the guidance of the specific section stated in Section 5.
- 5.1.1.3 Lubricate the machine specified by the lubrication schedule as stated in Section 5.2.
- 5.1.1.4 **Never** lubricate, adjust or remove material while it is running or in motion.
- 5.1.1.5 Torque all bolts and nuts to the settings specified in Section 5.9.

5.2 Lubrication & Greasing



CAUTION! When working with/checking the hydraulic system on the machine always wear safety glasses and impenetrable gloves. This also applies when working with gearboxes and gearbox oil. Use paper or cardboard to search for leaks and not hands or any other body parts.



CAUTION! Keep hands and body away from pin holes and nozzles ejecting hydraulic fluid. Ingested or penetrated hydraulic fluid in the body can become gangrenous. Removal must be carried out professionally by a suitable Doctor.

The mechanical components of the machine in use must be lubricated to avoid wear and heat build-up. Lubrication may be through the use of grease or oil. Oil allows higher relative speeds of items such as gearboxes, whereas grease is generally used to lubricate items such as bearings or bushes. In both cases it is important to ensure lubrication is given to these various items to ensure their longevity and reliability in use.

5.2.1 Gearboxes

	<p>Equipment Required</p> <ul style="list-style-type: none"> • SAE EP80-90W or GL-4/GL-5 oil • 17mm hex spanner (splitter gearbox guard) • 19mm hex spanner (dipstick) • 24mm hex spanner (drain for splitter gearbox) • 13mm hex spanner (drain for centre/wing gearbox)
--	-------------------------------------------------------------------------------------------------------------------------------------------------------------------------------------------------------------------------------------------------------------------------------------------------------------------------------------

The gearboxes have been filled to the correct quantities prior to shipment. However, the oil level should be **checked on the dipstick before operating the machine for the first time and regularly thereafter**. It is important to fill and maintain the gearboxes with the correct quantities of oil. Overfilling the gearbox with oil does not improve lubrication and may cause overheating. Using an under filled gearbox can cause overheating and premature wear to components such as seals.

The quantity of oil to use in each of the respective gearboxes is determined by the filling marks on the dipstick and the guide quantity to the amount of oil required for the particular gearbox is given approximately in Table 5.1.

There are grooves marked in the dipstick with Figure 5.2 (A) showing the upper level and Figure 5.2 (B) showing the lower level.

Spearhead and the gearbox manufacturer, Bondioli & Pavesi, recommend **SAE EP80-90W or GL-4/GL-5 oil** to fill its gearboxes. **Any different or higher SAE grade of oil is not recommended.**

	Stubble Master 500/730
Splitter Gearbox (A)	2.65 litres (4.66 pints)
Rotor Gearbox (B)	2.10 litres (3.70 pints)

Table 5.1 – Stubble Master Gearbox Oil Capacities

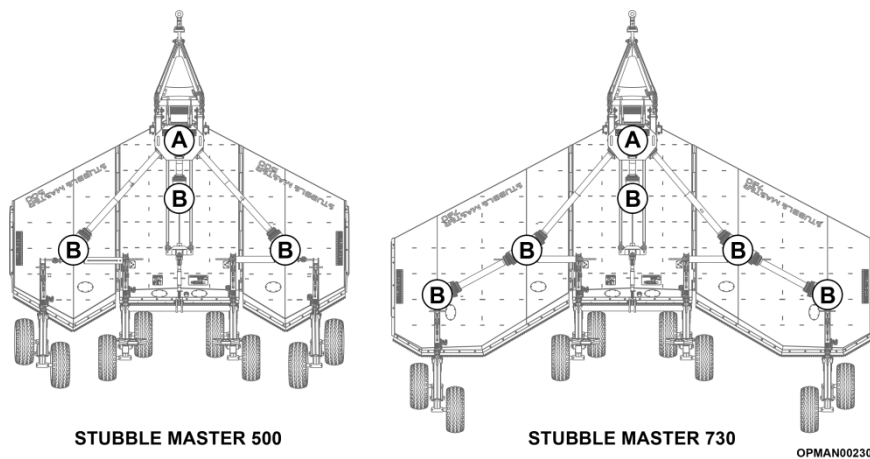

Figure 5.1 - Stubble Master Gearbox Oil Capacity Locations

Changing the oil regularly prevents problems associated with deterioration, moisture build up in the oil and the potential presence of metallic particles which form early in the machines life. Oil changes are recommended on Stubble Master machines **after the first 50 hours, and then every 500 hours thereafter.**

To drain the oil, each of the gearboxes is fitted with a **drain plug**. With reference to Figure 5.3, the locations of these drain plugs highlighted in red can vary. If there are facilities to vacuum draw the oil out of the respective gearbox, the oil can be changed through the fill hole/dipstick location instead which is considerably easier.

The positioning of the dipstick can vary between gearboxes, due to their engineering restrictions. However, they should always be at the top. The drain plugs for gearboxes are always located near the bottom of the gearbox; see Figure 5.3.

The gearbox should not require additional lubricant unless the box is cracked or a seal is leaking. It is recommended that the oil level is **checked every day before operation** and additional oil added if it's required to bring it up to the upper level mark Figure 5.2 (A) **before proceeding to use the machine.** The splitter gearbox guard has a cut-out in order to check the oil level without having to open the guard.

Stubble Master splitter box gearboxes (Figure 5.1 (A)) have a guard to protect the casing. In order to check the oil level in this gearbox requires the removal of the two bolts to hinge the guard open to access the gearbox dipstick; see Figure 5.2.

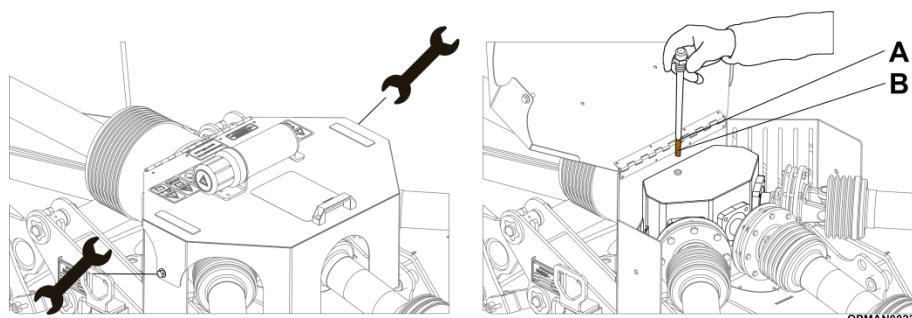

Figure 5.2 – Stubble Master Oil Dipstick Marks

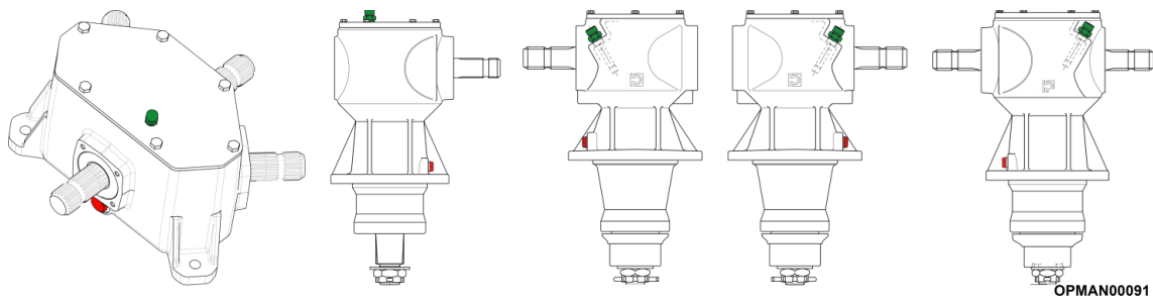

Figure 5.3
Stubble Master Gearbox Level & Drain Plug Varying Locations

5.2.2 PTO Shaft



Equipment Required

- Manually operated grease gun supplying NLGI #2 Molybdenum Disulphide Grease to M6/M8 grease nipples

IMPORTANT: Proper and correct frequency of lubrication of all the rotating and sliding parts of the various PTO shafts fitted to the machine is essential for the correct function, longevity and reliability of the shaft. Insufficient lubrication or contamination is one of the most frequent causes of PTO shafts.

The joints, telescopic member and shields must be lubricated at intervals related to the environment and working conditions for the machine.

Bondioli & Pavesi recommend **NLGI #2 Molybdenum Disulphide Grease** on all crosses, telescoping members and shields. This grease contains additives which offer corrosion resistance, strength and adhesion at extreme pressures (EP) along with other benefitting properties.

When lubricating cross kits, pump grease until the grease purges from all four bearing caps. **Pump the grease gradually.** Avoid high pressures, especially those possible from pneumatic equipment.

The U-joint and CV joint assemblies on each of the different shafts are accessible by rotating the plastic safety shield until the cut-out hole allows the grease point to be exposed. When maintaining the shafts inspect the U-joint for movement by holding the shaft on either side of the U-joint and if there is noticeable play in the driveline, replace the U-joint before it causes severe damage to the driveline.

Figure 5.4 shows each of the respective shafts for the various Stubble Master machines.

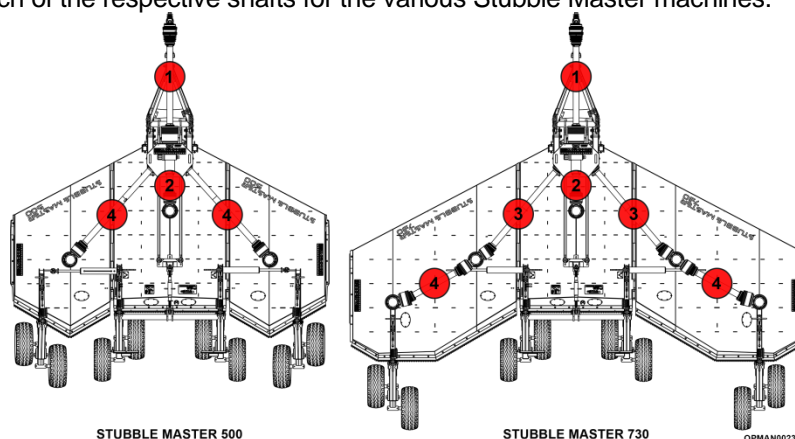

Figure 5.4 – Stubble Master Input Shaft Type Locations

Item No.	Shaft Type.
1	Input Shaft
2	Centre Shaft
3	Inner Shaft
4	Outer Shaft

Table 5.2 – Stubble Master Input Shaft Type Locations

NOTE: All values throughout this section are given on the assumption that a **manually operated grease gun** is used to carry out the greasing procedures giving a **predicted quantity of 0.8-1.0g of grease per pump**.

For reference to the required grease maintenance points on each of the respective shafts see below.



WARNING! It is mandatory to switch the combustion engine off and disengage PTO and ensure that the tractor and machine is stopped, the ignition key is removed from the dashboard and the parking brake is engaged before leaving the driver's seat and proceeding to carry out maintenance on any of the PTO shafts.

Input Shaft (1)

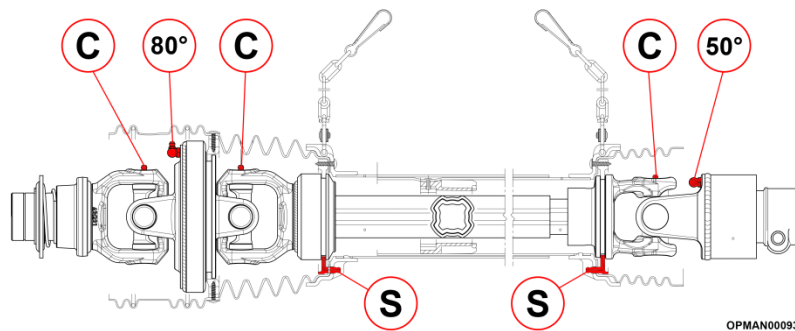

Figure 5.5 – Stubble Master Input Shaft Grease Locations

Model	PTO Input Speed (Shaft Size)	Quantity of Pumps			
		(C) - Cross	(S) – Shield Bearings	(80°) - 80° CV Joint	(50°) – (50°) CV Joint
Stubble Master 500	1000 (S6)	13	6	60	6
Stubble Master 730	1000 (S8)	22	6	80	7

Table 5.3 – Stubble Master Input Shaft Grease Quantities

Centre Shaft (2)

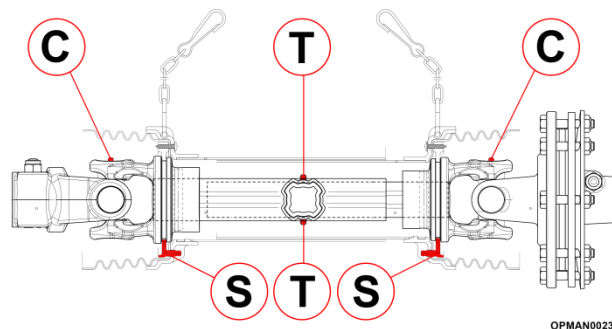

Figure 5.6 – Stubble Master Centre Shaft Grease Location

Model	PTO Input Speed (Shaft Size)	Quantity of Pumps		
		(C) - Cross	(S) – Shield Bearings	(T) – Telescopic Members
Stubble Master 500/730	1000 (S6)	13	6	20

Table 5.4 – Stubble Master Centre Shaft Grease Quantities

Inner Wing Shaft (3)

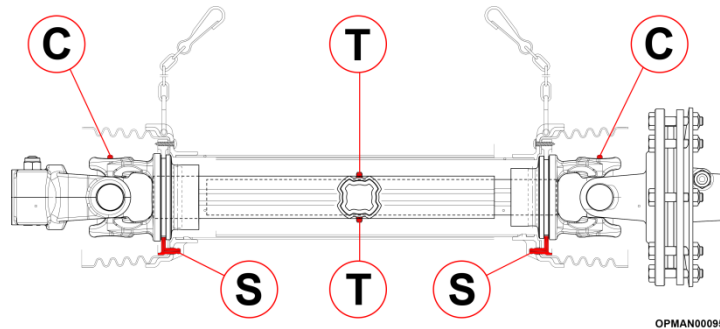

Figure 5.7 – Stubble Master Inner/Outer Wing Shaft Grease Locations

Model	PTO Input Speed (Shaft Size)	Quantity of Pumps		
		(C) - Cross	(S) – Shield Bearings	(T) – Telescopic Members
Stubble Master 730	1000 (S6)	13	6	20

Table 5.5 – Stubble Master Inner Wing Shaft Grease Quantities

Outer Wing Shaft (4)

Refer to Figure 5.7 for reference to grease points

Model	PTO Input Speed (Shaft Size)	Quantity of Pumps		
		(C) - Cross	(S) – Shield Bearings	(T) – Telescopic Members
Stubble Master 500/730	1000 (S6)	13	6	20

Table 5.6 – Stubble Master Outer Wing Shaft Grease Quantities

5.2.3 General Machine Greasing Point Locations

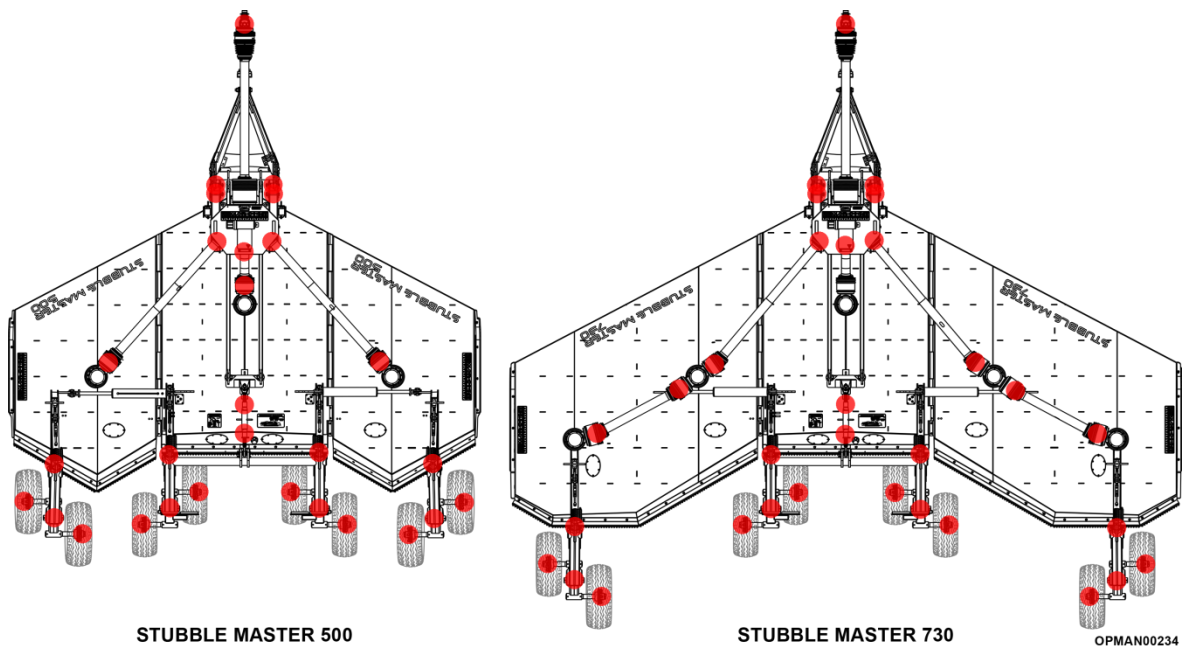

Figure 5.8 – Stubble Master Grease Point Locations

See Section 5.2.4 for reference to the routine greasing schedule for each of the relevant locations on each of the Stubble Master machines.

5.2.4 Greasing Schedule



Equipment Required

- Manually operated grease gun supplying NLGI #2 Molybdenum Disulphide Grease to M6/M8 grease nipples

With reference to the position of grease points in Figure 5.8, the following greasing schedule should be adhered to, to ensure reliability and longevity in components.

IMPORTANT: With extended and harder working conditions, these greasing times may need to be shortened to compensate for the machine more intensive work requirements.

NOTE: All values throughout this section are given on the assumption that a **manually operated grease gun** is used to carry out the greasing procedures giving a **predicted quantity of 0.8-1.0g of grease per pump**.



WARNING! It is mandatory to switch the combustion engine off and disengage PTO and ensure that the tractor and machine is stopped, the ignition key is removed from the dashboard and the parking brake is engaged before leaving the driver's seat and proceeding to carry out maintenance on any of the PTO shafts.

Grease Point	Qty (pumps)	Frequency
Input PTO Shaft	See Section 5.2.2 - Input Shaft (1)	
Centre Shaft	See Section 5.2.2 - Centre Shaft (2)	
Inner Wing PTO Shaft	See Section 5.2.2 – Inner Wing Shaft (3)	
Outer Wing PTO Shaft	See Section 5.2.2 – Outer Wing Shaft (4)	
Drawbar	2	Every 8 hours
Tie Bar Adjuster	2	Every 8 hours
Axle Mount Bushes	4	Every 8 hours
Wheel Bogies	2	Every 8 hours
Wheel Hubs	2	Every 8 hours

Table 5.7
Greasing Schedule For Various Components

5.3 PTO Shaft

Spearhead Stubble Master machines feature Bondioli & Pavesi gearboxes and PTO drive shafts. PTO shafts require routine maintenance and sometimes more demanding maintenance requirements to ensure their longevity and reliability of service.

For frequent greasing requirements of the various driveline shafts on the machine; see Section 5.2.2.

5.3.1 Size Adjustment & Fitting To The Tractor

The input PTO shaft supplied with the Stubble Master machine will be of standard supply as it came from the original manufacturer.

The input PTO shaft will be required to be modified/adjusted in order to fit the desired operating tractor. For guidance in how to carry this out; see Section 3.3.4.

For fitting the input PTO shaft between the machine and the tractor; see Section 4.5.

5.3.2 Greasing

For the greasing requirements on all Stubble Master input, wing and centre shafts, refer to Section 5.2.2.

5.3.3 Input PTO shaft - Bearing Ring Replacement

Plastic wear bearing rings are found inside the PTO assembly to give a replaceable wearing surface between the metal PTO shaft and the outer plastic safety shield/cone. Due to the parts design aim, the wear rings inside the PTO assembly **will be required to be replaced over the working life of the PTO shaft** to ensure that the outer plastic safety shield/cone doesn't wear through and expose the rotating PTO shaft found inside.

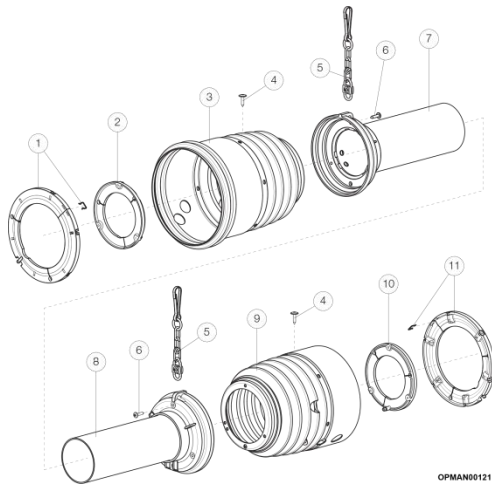

Item.	Description.
1	Support bearing for 80° CV joints with retaining spring
2	Outer pipe support bearing
3	Shield for 80° joint
4	Flanged screw
5	Chain
6	Self-tapping screw
7	Taper + outer pipe
8	Taper + inner pipe
9	Shield for 50° joint
10	Inner pipe support bearing
11	Support bearing for 50° CV joints with retaining spring

Figure 5.9/Table 5.8 - Input Shaft Safety & Wearing Components

Following this section will allow the successful removal and replacement of the bearing spacer wear rings.

Input PTO shaft - Bearing Ring Replacement – DISASSEMBLY



Equipment Required

- Phillips head screwdriver
- Flat head screwdriver

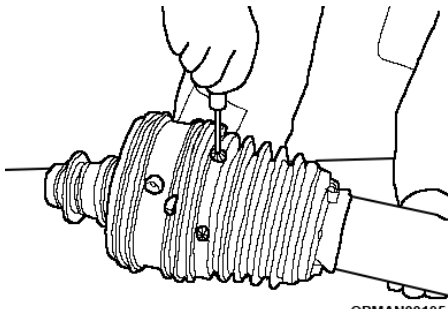

OPMAN00105

Figure 5.10

- 5.3.3.1 Remove the screws arranged radially around the circumference of the CV cone

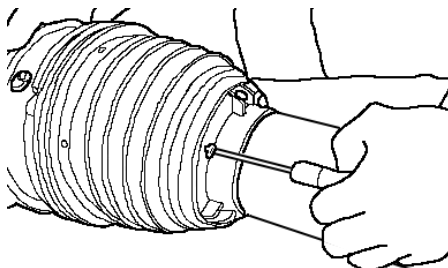

OPMAN00106

Figure 5.11

- 5.3.3.2 Remove the screws from the base of the cone

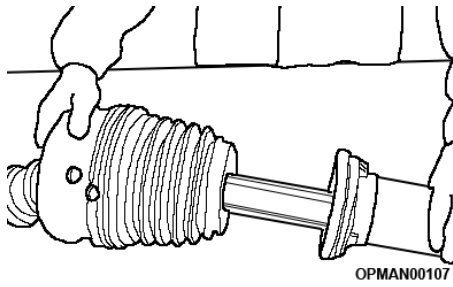

Figure 5.12

5.3.3.3 Remove the base cone and the shield tube

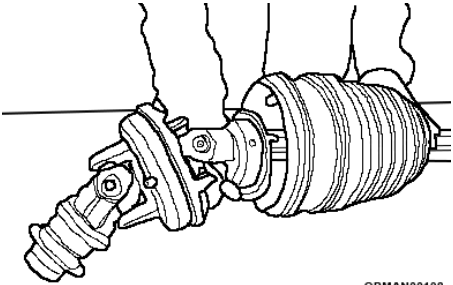

Figure 5.13

5.3.3.4 Remove the CV cone

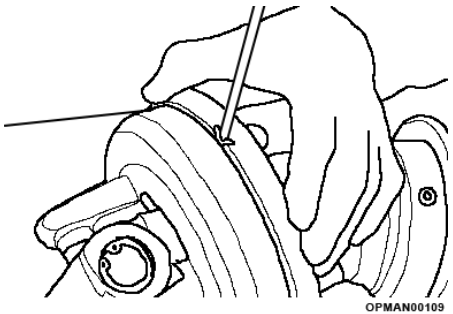

Figure 5.14

5.3.3.5 Disengage the retaining spring, leaving it inserted in one of the two holes of the bearing ring to avoid losing it

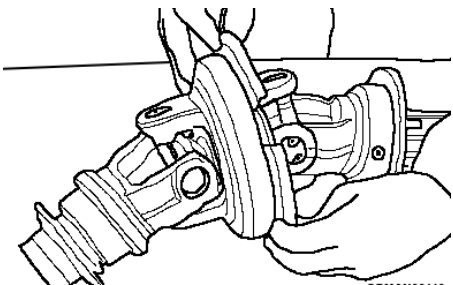

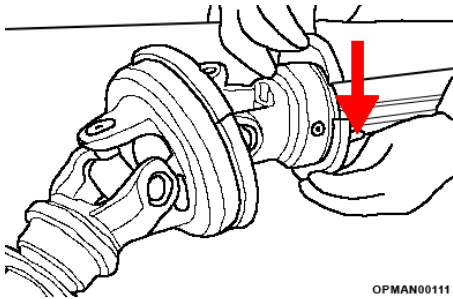

Figure 5.15

5.3.3.6 Spread the bearing rings and remove from their groove

Input PTO shaft - Bearing Ring Replacement – REASSEMBLY

	<p>Equipment Required</p> <ul style="list-style-type: none"> • Phillips head screwdriver • Flat head screwdriver • NLGI #2 Molybdenum Disulphide grease with paint brush/distributor
-----------------------------------------------------------------------------------	------------------------------------------------------------------------------------------------------------------------------------------------------------------------------------------------------------------------------



OPMAN00111

Figure 5.16

- 5.3.3.7 Grease the bearing grooves. Fit the bearing ring into the yoke groove with the grease fitting facing the drive tube

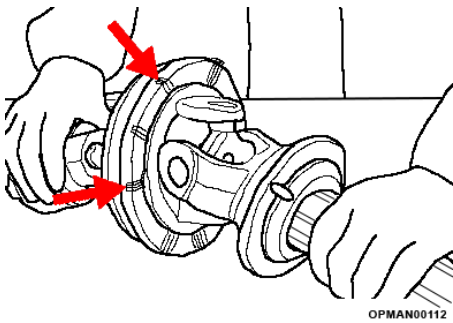

OPMAN00112

Figure 5.17

- 5.3.3.8 Install the bearing ring on the CV body with the reference pins facing the inner yoke

50° CV joints feature a bearing ring equipped with a grease fitting

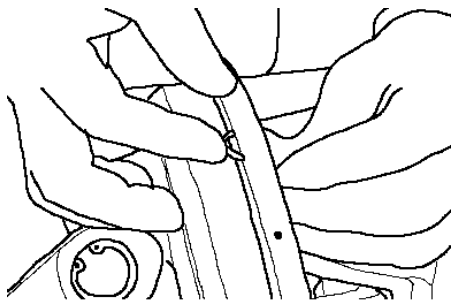

OPMAN00113

Figure 5.18

- 5.3.3.9 Connect the retaining springs to the two edges of the bearing ring

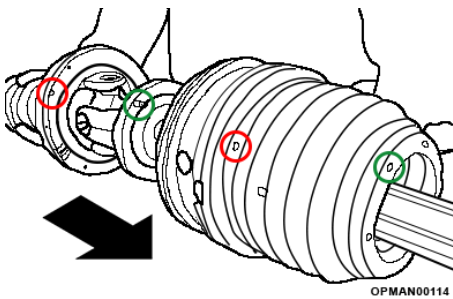

OPMAN00114

Figure 5.19

- 5.3.3.10 Slide the CV cone onto the CV body and align the radial holes with the bearing ring reference pins. Align the hole at the base of the CV cone with the grease fitting on the smaller bearing ring

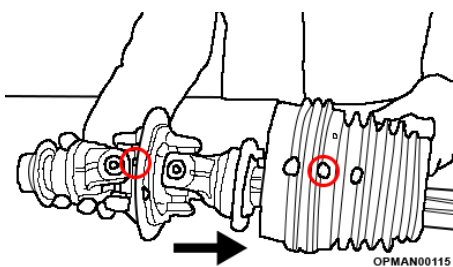

OPMAN00115

Figure 5.20

- 5.3.3.11 In the case of 50° CV joints only: insert the shield strip, aligning the reference pins and also the additional hole of the shield strip with the grease fitting of the large ring

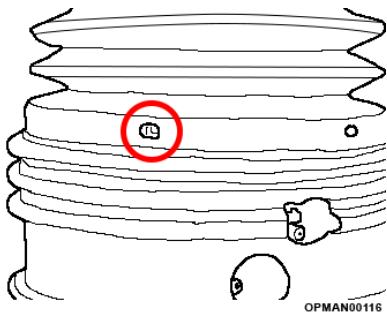

Figure 5.21

- 5.3.3.12 Ensure that the radial holes of the CV cone are aligned with the holes on the reference pins of the bearing ring

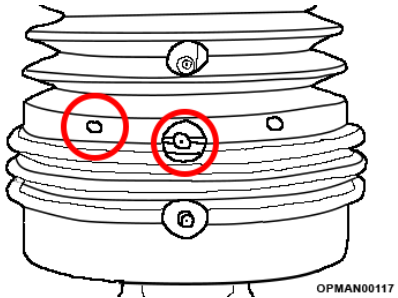

Figure 5.22

- 5.3.3.13 For 50° CV joints only, ensure that the radial holes of the shield strip are aligned with the holes on the reference pins of the bearing ring and that the access hole on the CV cone is aligned with the grease fitting of the bearing ring

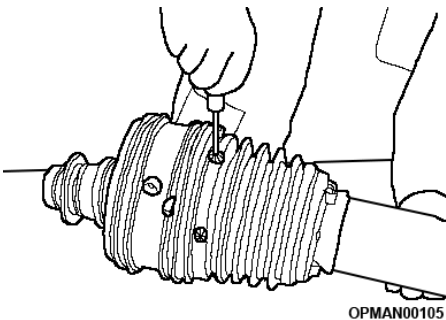

Figure 5.23

- 5.3.3.14 Tighten the 6 flange head screws of the protection strip. The use of an electric screwdriver is not recommended

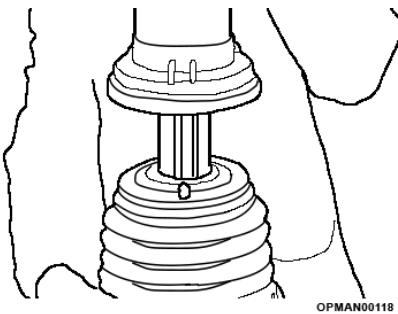

Figure 5.24

- 5.3.3.15 Fit the base cone and tube, inserting the grease fitting in the hole on the base cone

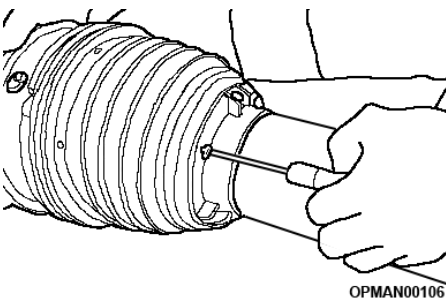
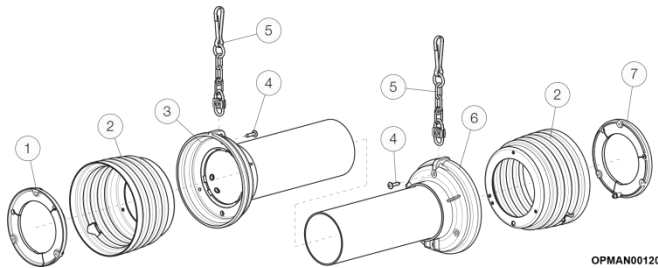

Figure 5.25

- 5.3.3.16 Tighten the 3 screws. The use of an electric screwdriver is not recommended

5.3.4 Wing PTO shaft - Bearing Ring Replacement

Plastic wear bearing rings are found inside the PTO assembly to give a replaceable wearing surface between the metal PTO shaft and the outer plastic safety shield/cone. Due to the parts design aim, the wear rings inside the PTO assembly will be required to be replaced over the working life of the PTO shaft to ensure that the outer plastic safety shield/cone doesn't wear through and expose the rotating PTO shaft found inside.



Item.	Description.
1	Outer pipe support bearing
2	End shield
3	Taper + outer pipe
4	Self-tapping screw
5	Chain
6	Taper + inner pipe
7	Inner pipe support bearing

Figure 5.27/Table 5.9 – Wing Shaft Safety & Wearing Components

Following this section will allow the successful removal and replacement of the bearing spacer wear rings.

Disassembly

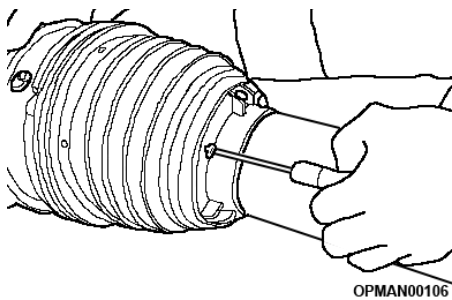
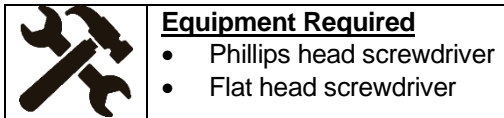

5.3.4.1 Remove the Philips head screws

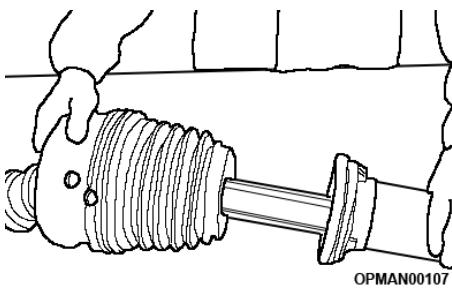

5.3.4.2 Remove the base cone and shield tube

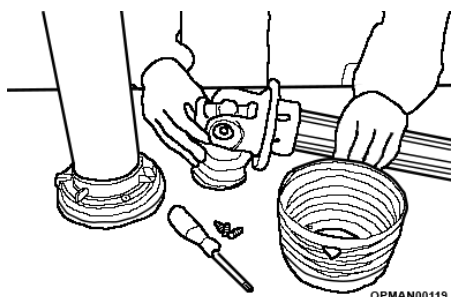

5.3.4.3 Remove the outer cone and the bearing ring

Reassembly

	<p>Equipment Required</p> <ul style="list-style-type: none"> • Phillips head screwdriver • Flat head screwdriver • NLGI #2 Molybdenum Disulphide grease with paint brush/distributor
-----------------------------------------------------------------------------------	------------------------------------------------------------------------------------------------------------------------------------------------------------------------------------------------------------------------------

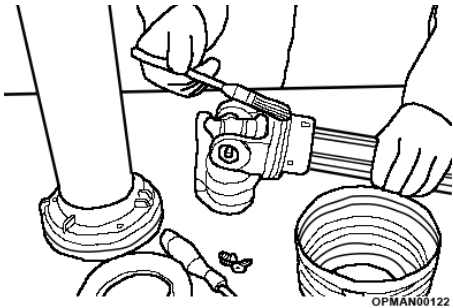

Figure 5.31

5.3.4.4 Grease the bearing groove on inner yokes

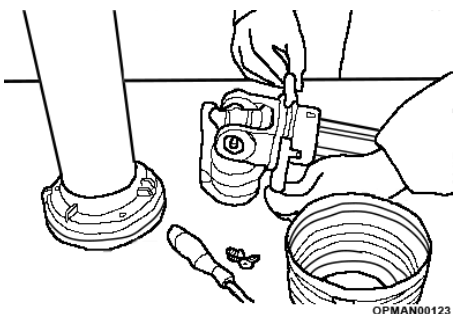

Figure 5.32

5.3.4.5 Fit the bearing ring into the yoke groove with the grease fitting facing the drive tube

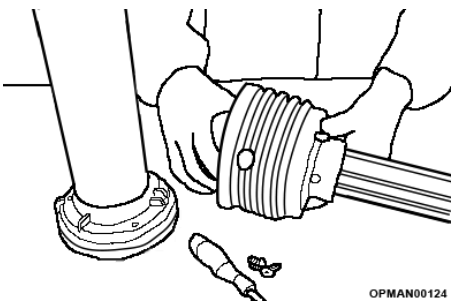

Figure 5.33

5.3.4.6 Install the outer cone, inserting the grease fitting through the proper hole

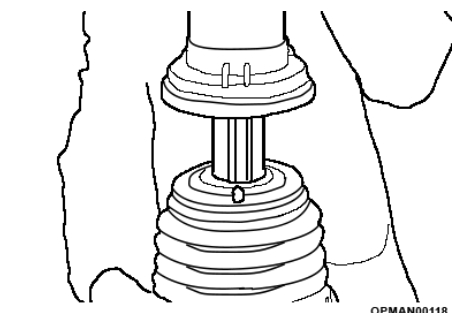

Figure 5.34

5.3.4.7 Install the base cone and shield tube

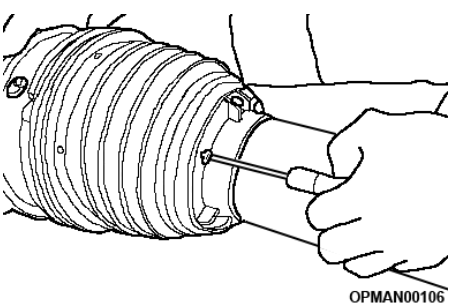

Figure 5.35

5.3.4.8 Tighten the Philips head screws. The use of an electric screwdriver is not recommended

5.4 Slip Clutch

To prevent gearbox damage all rotors are protected by slip clutches fitted to each of the drive shafts. FV friction slip clutches are found on the Stubble Master machine range, equipped with special Belleville springs designed to apply pressure that varies with the amount of compression.

In use, the compression of the spring **has to be adjusted periodically to compensate for lining wear and to maintain the correct clutch setting**. Clutch settings are stated in Section 5.4.3 for each of the respective Stubble Master machines.

5.4.1 Slip Clutch Disassembly & Servicing

Breakdown Of Components

Depending on the model of Stubble Master purchased there will be 180mm and/or 202mm clutches with either 2 and/or 4 friction linings. All versions have metal surfaces that are specially treated to help prevent sticking and corrosion of the friction linings.

Figure 5.36 and Figure 5.37 give a full breakdown of the slip clutches and where each type can be found on a machine.

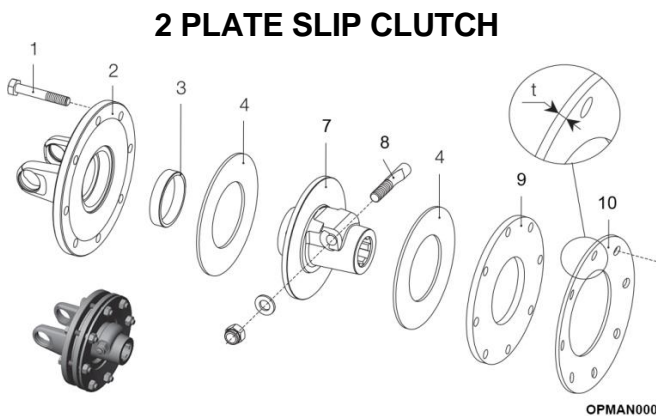

Figure 5.36

Applicable To:

- Stubble Master 500/730 centre shaft (reference: Figure 5.6)
- Stubble Master 500/730 outer wing shaft (reference: Figure 5.7)

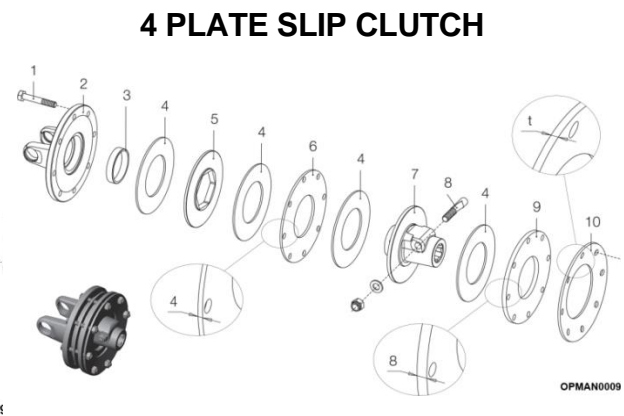

Figure 5.37

Applicable To:

- Stubble Master 730 inner wing shaft (reference: Figure 5.7)

1	Bolt
2	Flange yoke
3	Bushing
4	Friction lining
5	Driving plate
6	Inner plate (sp=4mm)
7	Hub
8	Taper pin kit
9	Pressure plate
10	Belleville spring

Table 5.10 – Slip Clutch Components

Disassembly

	Equipment Required
	• Digital Vernier caliper/micrometre
	• 19mm hex sockets/spanner
	• 2 x 17mm hex sockets/spanners

The following section refers to the disassembly operations of a slip clutch. This procedure can be carried out in the same fashion for either of the slip clutches shown earlier in the section.

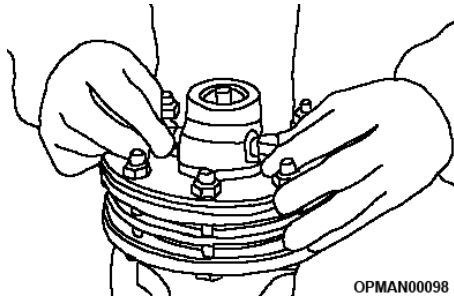

OPMAN00098

Figure 5.38

5.4.1.1 Remove the taper pin

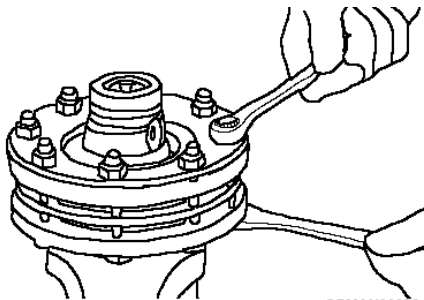

OPMAN00099

Figure 5.39

5.4.1.2 Unscrew progressively the 8 bolts in order to reduce the pressure uniformly on the discs and linings

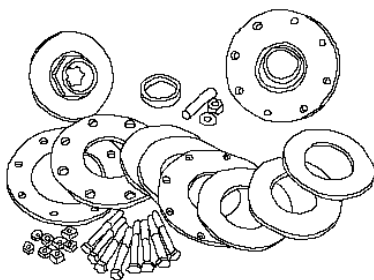

OPMAN00100

Figure 5.40

5.4.1.3 Remove the springs, discs and linings from the slip clutch

5.4.1.4 Verify the efficiency of all the parts of the slip clutch. Replace worn or damaged components with genuine Spearhead parts

NOTE: Clutch linings 'as new' thickness is 3.2mm. Replace the clutch linings when the thickness is reduced to 2.5mm.

Clean all metallic surfaces, especially those in contact with the clutch linings.

Reassembly

The following section refers to the reassembly operations of a slip clutch. This procedure can be carried out in the same fashion for either of the slip clutches shown in the Disassembly section.

	<p>Equipment Required</p> <ul style="list-style-type: none"> • Digital Vernier caliper/micrometre • 19mm hex sockets/spanner • 2 x 17mm hex sockets/spanners • NLGI #2 Molybdenum Disulphide grease with paint brush/distributor
-----------------------------------------------------------------------------------	-----------------------------------------------------------------------------------------------------------------------------------------------------------------------------------------------------------------------------------------------------------------------------------

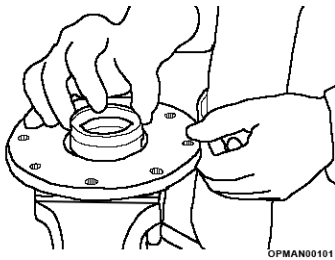

OPMAN00101

Figure 5.41

- 5.4.1.5 Apply a film of grease on the bushing surfaces and insert it into the flange yoke. Avoid excessive grease on the bushing

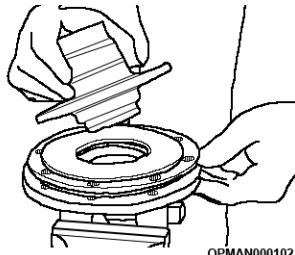

OPMAN00102

Figure 5.42

- 5.4.1.6 Assemble in sequence the other parts as shown in Figure 5.36 and Figure 5.37, depending on the PTO shaft in question

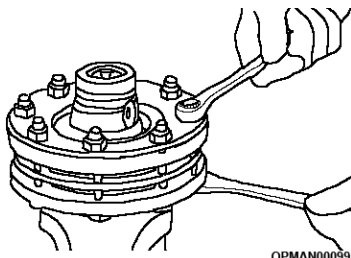

OPMAN00099

Figure 5.43

- 5.4.1.7 Insert the 8 screw with their heads on the flange yoke side

- 5.4.1.8 Turn all the nuts in contact with the spring

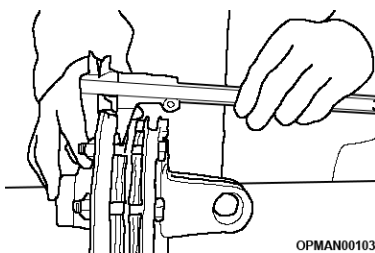

OPMAN00103

Figure 5.44

- 5.4.1.9 Tight progressively the bolts (e.g. half a turn per time) in order to uniformly compress the Belleville spring to its required compression "h"; see Figure 5.45

For slip clutch settings see Section 5.4.3 and select the correct machine/particular shaft required. The clutch setting is listed under column "h"

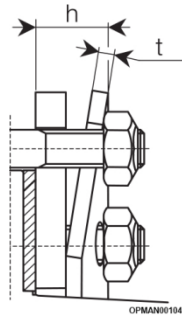

Figure 5.45

IMPORTANT: Do not over-tighten the bolts; this may endanger the function of the clutch.

IMPORTANT: Spearhead recommends to not modify the torque settings given in Section 5.4.3. Damages to implement, driveline or tractor may occur. Spearhead declines all responsibility for damage to implement, driveline or tractor caused by modifying **any** of the slip clutch settings on Stubble Master machines in any other way than described in this manual. **If you are unsure of the procedure**, or need additional assistance, please **contact your local Spearhead dealer, qualified service centre or Spearhead**.

5.4.2 Freeing Seized Clutch Plates



Equipment Required

- Digital Vernier caliper/micrometre
- 2 x 17mm hex sockets/spanners

If the machine has been **laid up for any length of time**, there is a risk of the clutch plates rusting and **seizing together**. Never operate the machine if it is in/potentially in this condition, as there will be no protection to the driveline and gearboxes against shock loading.

To free the clutch plates:

- 5.4.2.1 Slacken all compression spring bolts off the clutch plates; see Section 5.4.1.2.
- 5.4.2.2 Mark the outer plates in order to give a visual reference to if the clutch plates have freed or moved.
- 5.4.2.3 Run the machine **temporarily** in an aim to cause the clutch to slip with the tractor speed at around 1000 rpm.
- 5.4.2.4 Retighten the compression bolts to the correct distance for the particular clutch in question; see Section 5.4.1.5 to 5.4.1.9.

IMPORTANT: Do not over-tighten the bolts; this may endanger the function of the clutch.

If you are unsure of the procedure, or need additional assistance, please **contact your local Spearhead dealer, qualified service centre or Spearhead**.

As a procedure to stop the above listed problem occurring, Spearhead recommends that slip clutches are released when the machine is laid up for any longer than 7 days.

5.4.3 Clutch Settings

The tables listed out throughout this section give the settings for the various clutches on each of the Stubble Master machines.

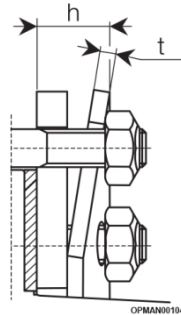

Figure 5.46 – Clutch Setting Dimension Guidance

Stubble Master 500 Clutch Settings

Machine	Clutch	Shaft Part No.	Qty Plates/Size	Clutch Setting (h)*
Stubble Master 500	Centre Shaft	5770225	2 plate/202mm	19mm
	Wing Shaft	5770230	2 plate/202mm	17.5mm

Table 5.11

NOTE: The height “h” of the spring must be measured next to each bolt and may be ± 0.2 mm of the given value

Stubble Master 730 Clutch Settings

Machine	Clutch	Shaft Part No.	Qty Plates/Size	Clutch Setting (h)*
Stubble Master 730	Centre Shaft	5770225	2 plate/202mm	19mm
	Inner Wing Shaft	5770231	4 plate/180mm	18.5mm
	Outer Wing Shaft	5770207	2 plate/202mm	18mm

Table 5.12

NOTE: The height “h” of the spring must be measured next to each bolt and may be ± 0.2 mm of the given value

5.5 Blades & Anti-Scalp Dishes

5.5.1 Blade Options

Stubble Master machines come with a combination of two different blade types; standard “Stubble Master” lifting blades and “Starcut” mulching blades. The blades are used in combination to create an effective double cut technique where the material is initially cut, lifted and then cut again and mulched.

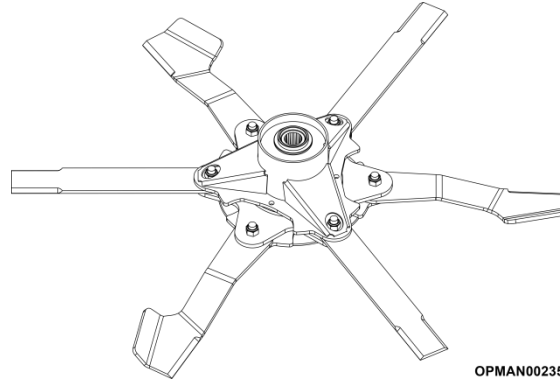

Figure 5.47 – Stubble Master Blade Assembly

5.5.2 Blade Inspection

Inspect the machine blades before each use to determine that they are properly installed, secure and in good condition. Replace any blade sets that are bent, excessively nicked, worn or have any other damage. If any blade is damaged it is important to replace **all three** blades on that rotor to retain the balance of the particular rotor. Failure to replace such abnormally damaged blades may lead to catastrophic failure of the blade and ejection of the broken part with tremendous force which may cause bodily injury or death.

See Table 5.15 for some visual indications of worn blades; the standard Stubble Master type and the Starcut blades.



	New		New
	Worn		Worn
Standard Stubble Master Blades		Starcut Blades	

Table 5.15 – Stubble Master/Starcut Worn/New Blade Comparison



DANGER! When carrying out maintenance work on or near the blades be careful of free-swinging blades over-centering and falling. Ensure Personal Protection Equipment (PPE) is worn.

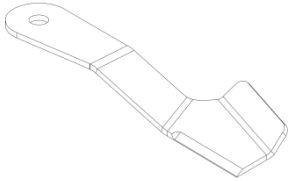
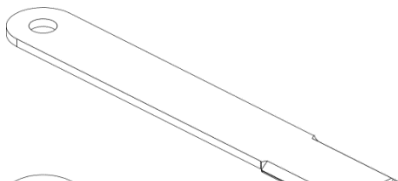
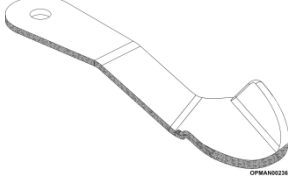

WARNING! Avoid personal injury. **Never work** under the machine without fixed support stands to ensure that the deck does not fall.

When servicing or inspecting blades of any type when the machine wings are folded, **it is important to ensure that the blade carrier and blade assembly is moved into its “dropped” position** to ensure nothing suddenly falls due to the force of gravity. When the Stubble Master machine is folded this should automatically happen, but if it hasn’t, hold the blades towards the outside and gradually rotate and pre-place them into their dropped

position; as shown in Figure 5.47. This will ensure that personnel do not get hit by falling blades or pinched/trapped between the blade and the carrier.

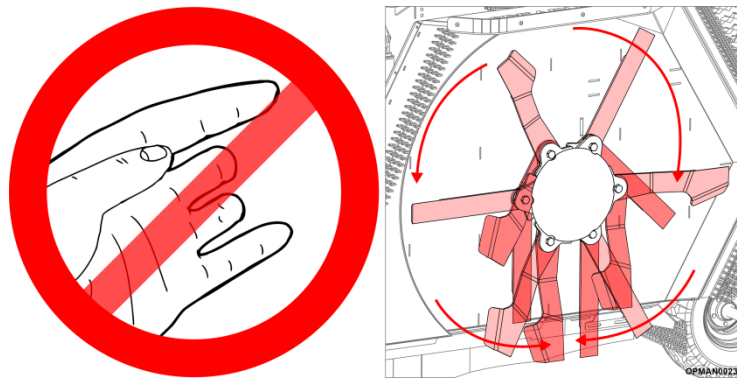

Figure 5.47 – Beware Of Falling Blades

Carefully wiggle the blade carrier assemblies and check each of the rotors for looseness of fasteners. Retighten any loose parts to the correct torque figure. See Section 5.4.3 for torque settings. **Blade carrier fasteners should be checked after the first hour and then every 8 hours thereafter.**



Equipment Required

- Torque wrench (see required settings in Torque Settings section)
- 2 x 36mm hex sockets/spanner

IMPORTANT: Operating with loose blade components will damage the blade carrier and blades. Whenever the blades have been removed or replaced, the tightness of components should be checked after the first hour and then every 8 hours thereafter.

When proceeding to inspect the blades, if any are showing any signs of severe wear, damage or cracking, they must be replaced immediately. Never attempt to weld the blades, as this will make them very brittle and dangerous. **Do not take risks with cutting blades – if in doubt replace.**



WARNING! Inspect the area before mowing. Foreign objects should be removed from the site prior to beginning work to prevent machine damage and/or operator, bystander or the environment. Any objects that cannot be removed must be clearly marked and carefully avoided by the operator.



WARNING! Pay special attention when working with the machine and do not allow the machine to touch fixed objects such as road drains, walls, shafts, curbs, guard rails, tracks etc. as these could break the blades or blade carrier which could cause debris to be thrown at very high speed from the machine. As a precaution fit 5 ram spacers into each of the centre and axle rams to raise the cutting height of the machine to ensure they do not collide when the machine is in work.

As a preventative measure and to **reduce blade wear and potential detrimental damage, inspect the destined working area of the machine to determine where foreign object hazards are.** Remove these hazards and if they aren't easily removable, place visual markers where items are to ensure that the tractor and machine does not come into contact with these hazards.

IMPORTANT: Always use genuine Spearhead parts when carrying out repairs and maintenance with thoughts to longevity and reliability of the machine and personnel safety. Spearhead blades are made of special heat-treated alloy steel. Substitute blades may not meet specifications and may fail in a hazardous manner that could cause injury.

Spearhead declines all responsibility for damage and/or injury caused by use of **anything** other than the blade carriers/blades which are supplied with the machine as new or sold as a spare part replacement sold by a genuine Spearhead parts dealer on Stubble Master machines.

See Section 7 for guidance on spare parts. The machine serial number will be required to be quoted. Serial plate location guidance can be found in Figure 1.5.

5.5.3 Blade Sharpening & Straightening

Spearhead **does not** recommend sharpening worn blades. **It is important that all the blades on a rotor, are of the same weight and length and are all present** to ensure the rotor remains balanced. By sharpening blades there is a chance of them overheating, which will affect the hardness of the blades; compromising safety to the operator, machine and bystanders.



DANGER! Never attempt to straighten or weld on blades. This is likely to cause potential cracks and other damage to the blade. Subsequent failure and possible serious injury will occur from thrown blades.

NOTE: Spearhead declines all responsibility for damage and/or injury caused by sharpening/straightening and/or modifying ANY of the standard or 'Starcut' blades on any Stubble Master machines. **If you are unsure of the condition** of your blades, and feel you need additional assistance, please **contact your local Spearhead dealer, qualified service centre or Spearhead**.

5.5.4 Blade Removal & Replacement



Equipment Required

- Torque wrench (see required settings in Torque Settings section)
- 36mm hex sockets/spanner
- 36mm hex spanner



WARNING! It is mandatory to switch the combustion engine off and disengage PTO and ensure that the tractor and machine is stopped, the ignition key is removed from the dashboard and the parking brake is engaged before leaving the driver's seat and proceeding to adjust the levelling of the machine.

Before proceeding to remove and replace the blades of the machine, correctly assess the condition of the blades by reading the guidance given in Section 5.5.2.

If blade replacement is required, in order to not need to remove the lower blade carrier of the rotor, remove and replace each of the blades of the machine one at a time. When replacing rotor assemblies with new blades, due to their free swinging ability, **it is important to fit new hardened bushes into the blades at the same time**. This can ensure the rotor is remained balanced. **Blade bolts and nuts should be replaced whenever blades and bushes** are removed; whether the blades or bushes are requiring replacement or not.

Standard Stubble Master blades are handed. It is important to **make a note of the direction** of the particular rotor in question and to ensure that the correct blade is fitted to the rotor and **correctly orientated**. For guidance on the rotation directions of each of the rotors, see Section 1.4.

Figure 5.49 shows the left-hand and right-hand blades definitions and the direction in which they're meant to cut. Starcut blades can be replaced in a similar fashion; however they are not handed.

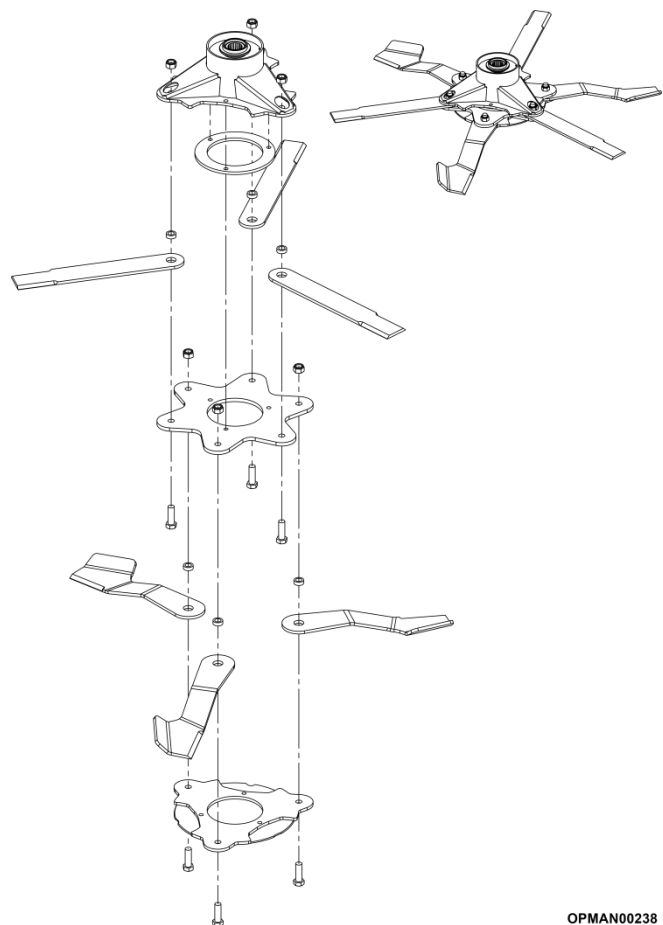

Figure 5.48 – Stubble Master Blade Carrier Assembly

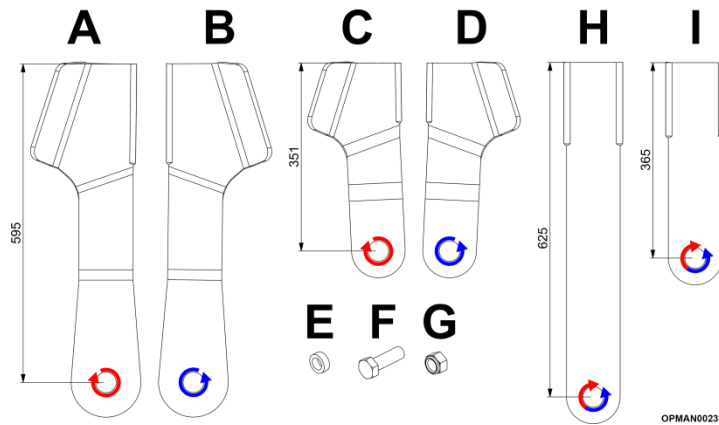

Figure 5.49
Stubble Master Range Standard Blade Components & Starcut Blades

Blade Quantities

Blade		Quantity Required	
		Stubble Master 500	Stubble Master 730
A	7770751	3	3
B	7770752	6	6
C	7770753	-	3
D	7770754	-	3
E	7770707	18	30
F	2770413	18	30
G	2770414	18	30
H	046001	9	9
I	062001	-	6

Table 5.16

5.5.5 Blade Bolt Inspection

Blade bolts are prone to getting damaged when coming in contact with foreign or solid objects which can seriously compromise the wellbeing of machine, the operator and bystanders. Neglecting damaged blade bolts can cause serious injury or death.

Inspect the heads of blade bolts daily for:

- Visible cracks
- Wear on the recessed area of the head of the bolt
- Gouges and chipped areas



DANGER! Failure to inspect daily and replace worn or damaged blade bolts may lead to catastrophic failure of the blades and ejection of the broken part which may cause serious bodily injury or death.

If any of these visual damages are found, replace **all blade bolts, nuts and bushes** on that rotor **immediately**.

IMPORTANT: Always replace blade bolts, nuts and bushes with new components whenever the machine blades are removed and/or replaced.



WARNING! Inspect the area before mowing. Foreign objects should be removed from the site prior to beginning work to prevent machine damage and/or operator, bystander or the environment. Any objects that cannot be removed must be clearly marked and carefully avoided by the operator.



WARNING! Pay special attention when working with the machine and do not allow the machine to touch fixed objects such as road drains, walls, shafts, curbs, guard rails, tracks etc. as these could break the blades or blade carrier which could cause debris to be thrown at very high speed from the machine. As a precaution fit 5 ram spacers into each of the centre and axle rams to raise the cutting height of the machine to ensure they do not collide when the machine is in work.

As a preventative measure inspect the destined working area of the machine to determine where foreign object hazards are. Remove these hazards and if they aren't easily removable, place visual markers where items are to ensure that the tractor and machine does not come into contact with these hazards.

5.5.6 Anti-scalp Dish Inspection

Anti-scalp dish lower blade carriers are found on the bottom of each of the rotors of the machine to protect the blades and the driveline. However, like the blades are potentially prone to coming into contact with immovable objects while the machine is in work. **Inspect the machine anti-scalp dishes before each use to determine that they are properly installed, secure and in good condition. Replace any blade carriers which are excessively nicked, worn or have any other damage.**

See Section 5.5.2 for some visual indications of worn anti-scalp dish lower blade carriers.

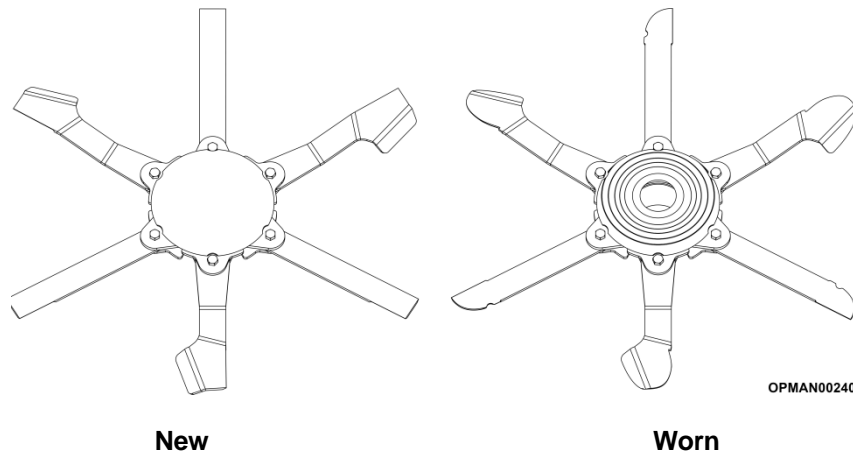

Figure 5.50 – New vs Worn Anti-scalp Dish Comparison



DANGER! When carrying out maintenance work on or near the blade carrier be careful of free-swinging blades over-centering and falling. It is recommended that Personal Protection Equipment (PPE) is worn.



WARNING! Avoid personal injury. **Never work** under the machine without fixed support stands to ensure that the deck does not fall.

When servicing or inspecting any anti-scalp dish lower blade carrier of any type when the machine wings are folded, it is important to ensure that the blade carrier and blade assembly is moved into its “dropped” position to ensure nothing suddenly falls due to the force of gravity. When the Stubble Master machine is folded this should automatically happen, but for any reason if it hasn't, sufficiently hold the blades towards the outside and gradually rotate and pre-place them into their dropped position; as shown in Figure 5.51. This will ensure that personnel do not get hit by falling blades or pinched/trapped between the blade and the carrier.

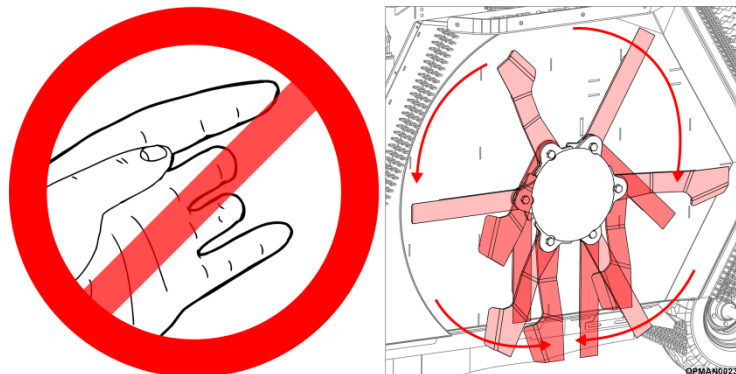



Figure 5.51 – Beware Of Falling Blades

	<p>Equipment Required</p> <ul style="list-style-type: none"> • Torque wrench (see required settings in Torque Settings section) • 36mm hex sockets/spanner • 36mm hex spanner
-----------------------------------------------------------------------------------	-----------------------------------------------------------------------------------------------------------------------------------------------------------------------------------------------------------------------

Carefully wiggle the blade carrier assemblies and check each of the rotors for looseness of fasteners. Retighten any loose parts to the correct torque figure. See Section 5.4.3 for torque settings. Blade carrier fasteners should be checked after the first hour and then every 8 hours thereafter.

IMPORTANT: Operating with loose blade components will damage the blade carrier and blades. Whenever the blades and blade carrier have been removed or replaced, **the tightness of components should be checked after the first hour and then every 8 hours** thereafter.



WARNING! Inspect the area before mowing. Foreign objects should be removed from the site prior to beginning work to prevent machine damage and/or operator, bystander or the environment. Any objects that cannot be removed must be clearly marked and carefully avoided by the operator.



WARNING! Pay special attention when working with the machine and do not allow the machine to touch fixed objects such as road drains, walls, shafts, curbs, guard rails, tracks etc. as these could break the blades or blade carrier which could cause debris to be thrown at very high speed from the machine.

As a preventative measure and to reduce blade and blade carrier wear and potential detrimental damage, inspect the destined working area of the machine to determine where foreign object hazards are. Remove these hazards and if they aren't easily removable, place visual markers where items are to ensure that the tractor and machine do not come into contact with these hazards.

IMPORTANT: Always use genuine Spearhead parts when carrying out repairs and maintenance with thoughts to longevity and reliability of the machine and personnel safety. Spearhead blade carriers are made of special heat-treated alloy steel. Substitute blade carriers may not meet specifications and may fail in a hazardous manner that could cause injury.

Spearhead declines all responsibility for damage and/or injury caused by use of **anything** other than the blade carriers/blades which are supplied with the machine as new or sold as a spare part replacement sold by a genuine Spearhead parts dealer on Stubble Master machines.

See Section 7 for guidance on spare parts. The machine serial number will be required to be quoted. Serial plate location can be found in Figure 1.7.

5.5.7 Anti-scalp Dish, Blade & Blade Carrier Removal & Replacement

IMPORTANT: Throughout this section be aware of the blade carrier rotating. Before proceeding to carry out any of the operations stated in this section; see Section 5.5.2 with regards to handling blade carrier assemblies safely.

Anti-scalp Dish, Blade & Blade Carrier Removal

	<p>Equipment Required</p> <ul style="list-style-type: none"> • Torque wrench (see required settings in Torque Settings section) • 36mm hex sockets/spanner • 36mm hex spanner • 55mm hex spanner • Needle nose pliers
-------------------------------------------------------------------------------------	---------------------------------------------------------------------------------------------------------------------------------------------------------------------------------------------------------------------------------------------------------------------------------

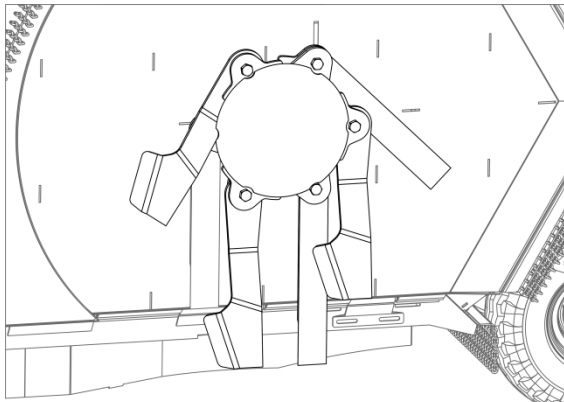

Figure 5.52

- 5.5.7.1 Ensuring that the blades and blade carrier are in their “dropped” and static position.

Remove the first standard blade and replace its fasteners after.

Repeat the process for the other two standard blades.



DANGER! When carrying out maintenance work on or near the blade carrier, be careful of free-swinging blades over-centering and falling. It is recommended that Personal Protection Equipment (PPE) is worn.

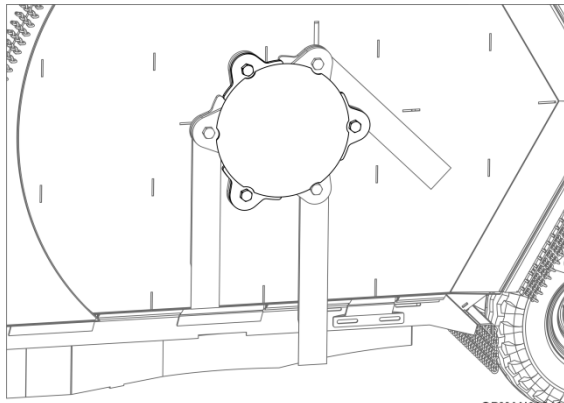

Figure 5.53

- 5.5.7.2 Fully remove the three blade standard fasteners and remove the anti-scalp dish assembly.

Remove the blade carrier spacer also.

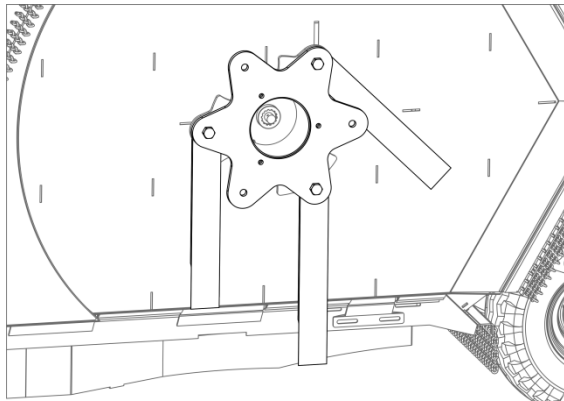

Figure 5.54

- 5.5.7.3 Remove the three bolts holding the Starcut blades and remove the Starcut blades and carrier (and the Starcut blade option blades if fitted).

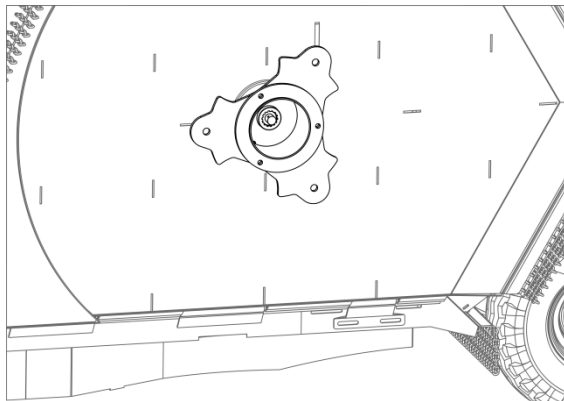

Figure 5.55

- 5.5.7.4 Remove the spacer plate, split pin and untighten the castle nut and free the upper blade carrier off the splined shaft.

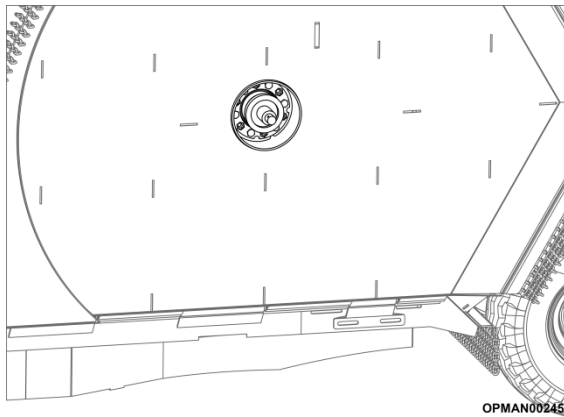

Figure 5.56

- 5.5.7.5 Inspect the underside of the gearbox and the gearbox seal protector for damage and ingressed debris.

Anti-scalp Dish, Blade & Blade Carrier Installation

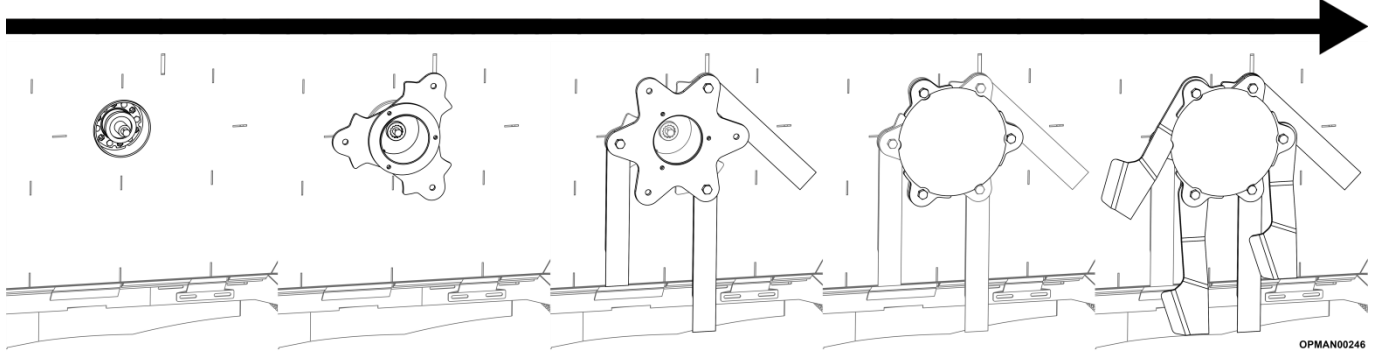



Figure 5.57
Anti-scalp Dish, Blade & Blade Carrier Installation

	<p>Equipment Required</p> <ul style="list-style-type: none"> • 36mm hex sockets/spanner • 36mm hex spanner • 55mm hex spanner • Needle nose pliers • NLGI #2 Molybdenum Disulphide grease with paint brush/distributor
-------------------------------------------------------------------------------------	----------------------------------------------------------------------------------------------------------------------------------------------------------------------------------------------------------------------------------------------------------------------------------

The complete blade carrier and blade assembly can be reassembled in a reverse fashion shown in the removal procedure.

Always assess the condition of all the components to see they're fit for purpose before reassembling.

- See Section 5.5.2 for assessing the condition of machine cutting blades.
- See Section 5.5.6 for assessing the condition of machine anti-scalp lower blade carriers.

Before reassembling the blade and blade carrier assembly assess the gearbox seal protector and seal ensuring it is in good condition and undamaged. Ensure the gearbox oil seal is not damaged and no ingressed wire or other material is in the protector. Before reassembly in general ensure that all components are checked for their condition and cleanliness.



DANGER! Failure to replace a worn or damaged gearbox shaft and/or upper blade carrier may lead to catastrophic failure of the carrier assembly and ejection of broken parts which may cause serious bodily injury or death.

When fitting the upper blade carrier to the gearbox shaft ensure that there is no play between the splines. **If in doubt replace.** Neglecting play in a worn gearbox shaft and/or upper blade carrier splines can cause serious injury or death. It can also create abnormal vibrations in the machine which in turn can damage other machine components.

IMPORTANT: Stop and do not use the machine when there is vibration in the machine, as this may cause breakage and serious damage. Find the cause of the vibration or have it inspected by personnel assigned by Spearhead and do not use the machine until the cause is identified and eliminated.

IMPORTANT: Always replace blade bolts and nuts and blade bushes with brand new items whenever blades are removed and/or replaced. For torque settings on the components; see Section 5.9.

IMPORTANT: Always use genuine Spearhead parts when carrying out repairs and maintenance with thoughts to longevity and reliability of the machine and personnel safety. Genuine Spearhead parts are made to specific standards to give performance and safety. Substitute components may not meet specifications and may fail in a hazardous manner that could cause injury.

Spearhead declines all responsibility for damage and/or injury caused by use of **anything** other than the genuine Spearhead parts on Stubble Master machines.

See Section 7 for guidance on spare parts. The machine serial number will be required to be quoted. For guidance on finding the serial plate location; see Figure 1.5.

5.6 Hydraulic Components

	Equipment Required
	<ul style="list-style-type: none"> • 2 x 19mm hex spanners • 2 x 8mm allen head socket/key • 2 x 22mm hex spanners • 2 x 27mm hex spanners • 6mm hex spanner

Before proceeding to carry out any maintenance requirements on the hydraulic system, ensure that you have thoroughly read and understood Section 2.4 on how to safely go about carrying out maintenance requirements to the machine, including how to approach the hydraulic system and its components. Section 2.3 should also be read to understand how to safely operate and use the machine in general.



CAUTION! Relieve hydraulic pressure before disconnecting the hydraulic hoses or working on the system. This can be done by pushing and pulling/pushing the selected tractor lever/button. Only once this has been completed and then suitable safety glasses and impenetrable gloves have been put on can the hydraulic hoses be removed from the tractor.



CAUTION! When working with/checking the hydraulic system on the machine always wear safety glasses and impenetrable gloves. This also applies when working with gearboxes and gearbox oil. Use paper or cardboard to search for leaks and not hands or any other body parts.



CAUTION! Keep hands and body away from pin holes and nozzles ejecting hydraulic fluid. Ingested or penetrated hydraulic fluid in the body can become gangrenous. Removal must be carried out professionally by a suitable Doctor.



CAUTION! Ensure all hydraulic hoses, lines and connections in good condition and tight before applying pressure.



CAUTION! Do not change any factory-set hydraulic settings to avoid component or equipment failures.



CAUTION! Ensure maintenance personnel wear suitable PPE clothing when maintaining the machine to ensure risk of impact or skin injuries. Suitable footwear and gloves are an example. For example frequent or prolonged contact with hydraulic oil may cause dermatitis and other skin disorders including (more rarely) skin cancer when not wear impenetrable gloves. Worn parts may have sharp edges.



CAUTION! Follow the guidance of the lubricant manufacturer with regards to handling oils, solvents, cleansers and other chemical agents.

5.6.1 Ram Inspection

Hydraulic rams should be inspected on a daily basis before commencing work. Ensure all hydraulic hoses, lines and connections in good condition and tight before applying pressure.

Inspect the ram and the accompanying fitted items to it:

- Check for play and wear in either end of the ram pear pin bushes and replace if necessary.
- Replace the ram immediately if there is any apparent distortion or corrosion on the plated ram rod.

If there is a leak apparent, determine where the cause of this leak is from. Causes could be due to the hydraulic ram, hose adaptors or the hydraulic hoses. **Replace the component at fault if in any doubt before proceeding to use the machine.** Hydraulic ram seal spares kits are available.

Where parts are broken, damaged and deemed not fit for use; replace with genuine Spearhead parts using the online Interactive Parts facility at:

<https://my.spearheadmachinery.com/parts/public-interactive-parts-database/>

You will require the machine serial number. Assistance to its location can be found in Section 1.3.

5.6.2 Wing Ram Replacement

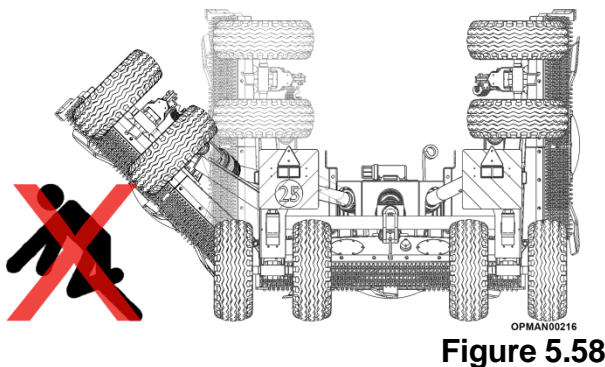
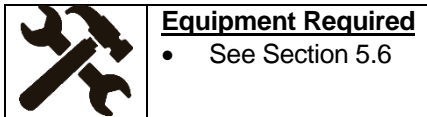

Figure 5.58

5.6.2.1 Clear the area of all personnel before lowering the wings; see Figure 5.58.

5.6.2.2 From the tractor seat with your belt fastened, lower the machine wings to the ground.



WARNING! When operating a fully assembled machine, do not release the ratchet securing strap until the hoses are attached to the tractor and each of the wing lift ram cylinders are filled with oil. Always ensure that bystanders are kept well away from the falling area of the wings.

5.6.2.3 Shut off the tractor and engage the parking brake before dismantling the tractor.

5.6.2.4 Fully support the centre and wing decks of the machine with fixed stands or substantial blocks; see Figure 5.59.

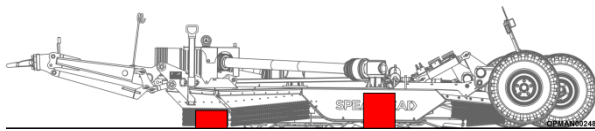

Figure 5.59

5.6.2.5 Release all oil pressure from the circuit by using the tractors hydraulic control levers/buttons back/forth in/out e.t.c.

5.6.2.6 Remove the input PTO shaft between the machine and tractor. Guidance to using the PTO shaft is given in Section 4.5.1.

5.6.2.7 Put on suitable safety glasses and impenetrable gloves and proceed to remove the hydraulic hoses from the tractors quick connect points following the guidance given in Section 4.3.

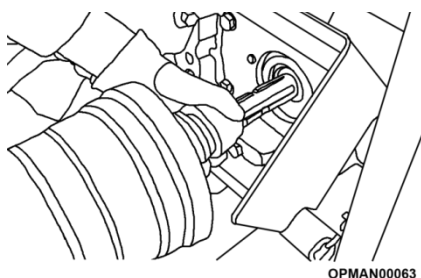

Figure 5.60

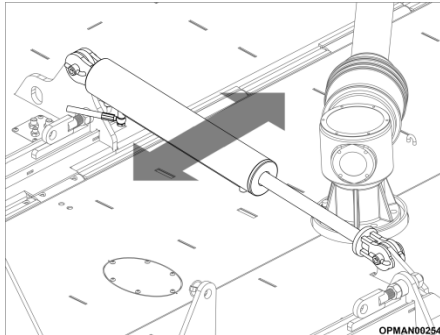

Figure 5.61

- 5.6.2.8 Check to see that the hydraulic cylinder destined to be removed is not under pressure.

There should be some slight movement in the ram by moving the ram by hand; see Figure 5.61. If no movement can be made; the system may still be under pressure.



DANGER! Do not allow anyone or any part of your body to be underneath the implement wing.

- 5.6.2.9 If no pressure in the ram is ensured, slowly loosen the hydraulic hose connections to the ram cylinder.



CAUTION! Do not loosen the hydraulic connections to the cylinder until all pressure has been relieved from the system.

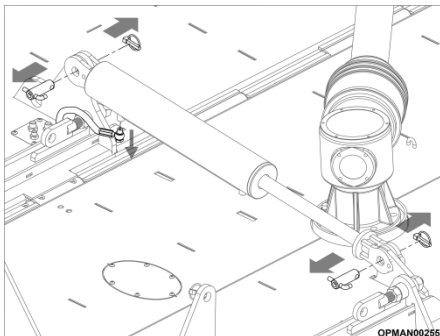

Figure 5.62

- 5.6.2.10 Ensuring that the hydraulic ram is movable and that the machine is supported substantially so it will not in reaction move, remove the cylinder pear pins from each of end of the ram. The cylinder may be heavy, use proper lifting techniques to lift and handle the cylinder and if needed get assistance in lifting from another person

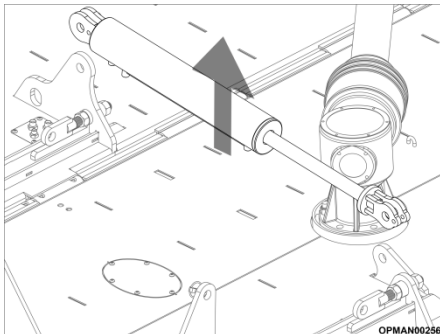

Figure 5.63

- 5.6.2.11 Inspect the hydraulic rams condition; see Section 5.6.1. Inspect the hydraulic ram port adaptors and seals to see they're serviceable and able to be used on the replacement ram.

- 5.6.2.12 Measure the distance between the cylinder pin holes on the old ram and extend the new cylinder to that length before installing.

- 5.6.2.13 Install the new cylinder in place and install both cylinder pins and pear pins in place.

- 5.6.2.14 Ensuring that you're still wearing suitable safety glasses and impenetrable gloves, reconnect the hydraulic hose(s) to the cylinder and tighten the fittings.

- 5.6.2.15 Reconnect the implement hoses to the tractor.

- 5.6.2.16 Get into the tractor seat and fasten your seat belt. Clear the area of all persons before attempting to raise the wing. From the tractor seat, start the tractor and operate the control valve to raise the wing.

- 5.6.2.17 Look for signs of oil leaks. If an oil leak exists, shut the tractor down and remove all oil pressure in the lines by moving the valve control handles back and forward.

Retighten any loose fittings and connections and if a hose is leaking, replace the hose with a new hose.

- 5.6.2.18 If there are no leaks, raise and lower the wing completely at least three full cycles to remove any air trapped in the circuit.

- 5.6.2.19 Check the hydraulic reservoir of the tractor to ensure there is sufficient oil.
- 5.6.2.20 If the wing is to remain in the raised position attach the wing transport strap; see Figure 4.17.
- 5.6.2.21 If the machine is planned to be used straight after, inspect the machine to ensure that it will achieve a level cut. See Section 4.7 for guidance on levelling the machine.

5.6.3 Axle Lift Ram Replacement

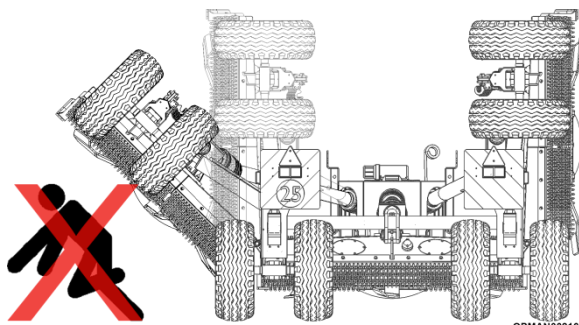
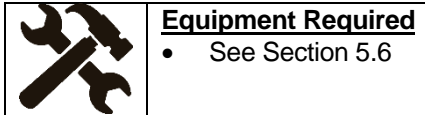

Figure 5.64

- 5.6.3.1 Clear the area of all personnel before lowering the wings; see Figure 5.64.
- 5.6.3.2 From the tractor seat with your belt fastened, lower the machine wings to the ground following the guidance given in Section 4.2.



WARNING! When operating a fully assembled machine, do not release the ratchet securing strap until the hoses are attached to the tractor and each of the wing lift ram cylinders are filled with oil. Always ensure that bystanders are kept well away from the falling area of the wings.

- 5.6.3.3 Shut off the tractor, engage the parking brake, place the tractor transmission into the parked position and remove the key before dismantling the tractor.

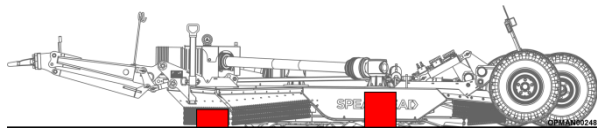

Figure 5.65

- 5.6.3.4 Fully support the centre and wing decks of the machine with fixed stands or substantial blocks; see Figure 5.65.

- 5.6.3.5 Release all oil pressure from the circuit by using the tractors hydraulic control levers/buttons back/forth in/out e.t.c.

- 5.6.3.6 Remove the input PTO shaft between the machine and tractor. Guidance to using the PTO shaft is given in Section 4.5.1.

- 5.6.3.7 Put on suitable safety glasses and impenetrable gloves and proceed to remove the hydraulic hoses from the tractors quick connect points following the guidance given in Section 4.3.

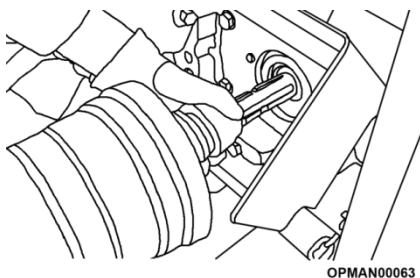

Figure 5.66

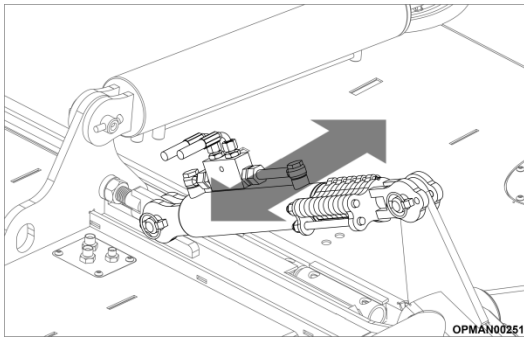

Figure 5.67

- 5.6.3.8 Check to see that the hydraulic cylinder destined to be removed is not under pressure.

There should be some slight movement in the ram by moving the ram by hand. If no movement can be made; the system may still be under pressure.



DANGER! Do not allow anyone or any part of your body to be underneath the implement deck.

- 5.6.3.9 If no pressure in the ram is sure, slowly loosen the hydraulic hose connections to the ram cylinder.



CAUTION! Do not loosen the hydraulic connections to the cylinder until all pressure has been relieved from the system.

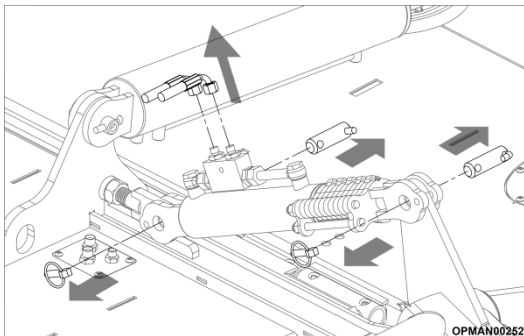

Figure 5.69

- 5.6.3.10 Ensuring that the hydraulic ram can move and that the machine is supported substantially so it will not in reaction move, remove the cylinder pear pins from each of end of the ram. The cylinder may be heavy, use proper lifting techniques to lift and handle the cylinder and if needed get assistance in lifting from another person.

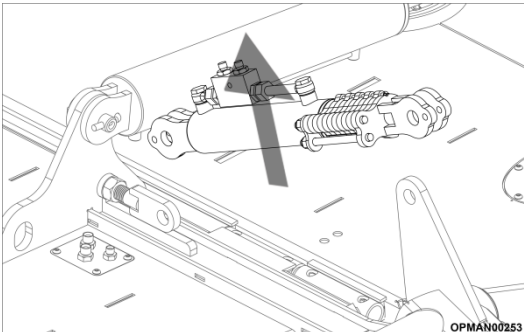

Figure 5.70

- 5.6.3.11 Inspect the hydraulic rams condition. If the hydraulic ram port adaptors and seals are serviceable, they can be removed and installed on the replacement ram.

- 5.6.3.12 Measure the distance between the cylinder pin holes and extend the new cylinder to that length.

- 5.6.3.13 Install the cylinder in place and install both cylinder pins and retaining bolts in place.

- 5.6.3.14 Ensuring that you're still wearing suitable safety glasses and impenetrable gloves, reconnect the hydraulic hose(s) to the cylinder and tighten the fittings.

- 5.6.3.15 Reconnect the implement hoses to the tractor.

- 5.6.3.16 Get into the tractor seat and fasten your seat belt. Clear the area of all persons before attempting to raise the decks. From the tractor seat, start the tractor and operate the control valve to raise the decks.

- 5.6.3.17 Look for signs of oil leaks. If an oil leak exists, shut the tractor down and remove all oil pressure in the lines by moving the valve control handles back and forward.

Retighten any loose fittings and connections and if a hose is leaking, replace the hose with a new hose.

- 5.6.3.18 If there are no leaks, raise and lower the decks completely at least three full cycles to remove any air trapped in the circuit

5.6.3.19 Check the hydraulic reservoir of the tractor to ensure there is sufficient oil.

5.6.3.20 If the machine is planned to be used straight after, inspect the machine to ensure that it will achieve a level cut. See Section 4.7 for guidance on levelling the machine.

5.6.4 Hoses

	<p>Equipment Required</p> <ul style="list-style-type: none"> • See Section 5.6
-----------------------------------------------------------------------------------	------------------------------------------------------------------------------------------------------

Replace pinched and broken hydraulic hoses at once. Tighten any hydraulic fitting with fluid leaking from it. If fluid still leaks, loosen the fitting, apply a pipe thread compound to the threads and tighten. Care must be exercised when tightening hydraulic fittings. Too much tightening can cause the fittings to crack and require replacement fittings.

Hydraulic hose fitting torque setting are found in Section 5.9.2.

Although a small amount of oil will present from bleeding at all hydraulic fittings, significant amount of oil leaking from around the breather plug on the cylinder indicates that the seal in the cylinder is worn out. Replace the seals in the cylinder immediately before the cylinder is damaged or too much hydraulic fluid is lost.



CAUTION! Do not use the machine if the tractor hydraulic oil temperature exceeds 93° (200°F).

5.6.5 Machine Hose Diagrams

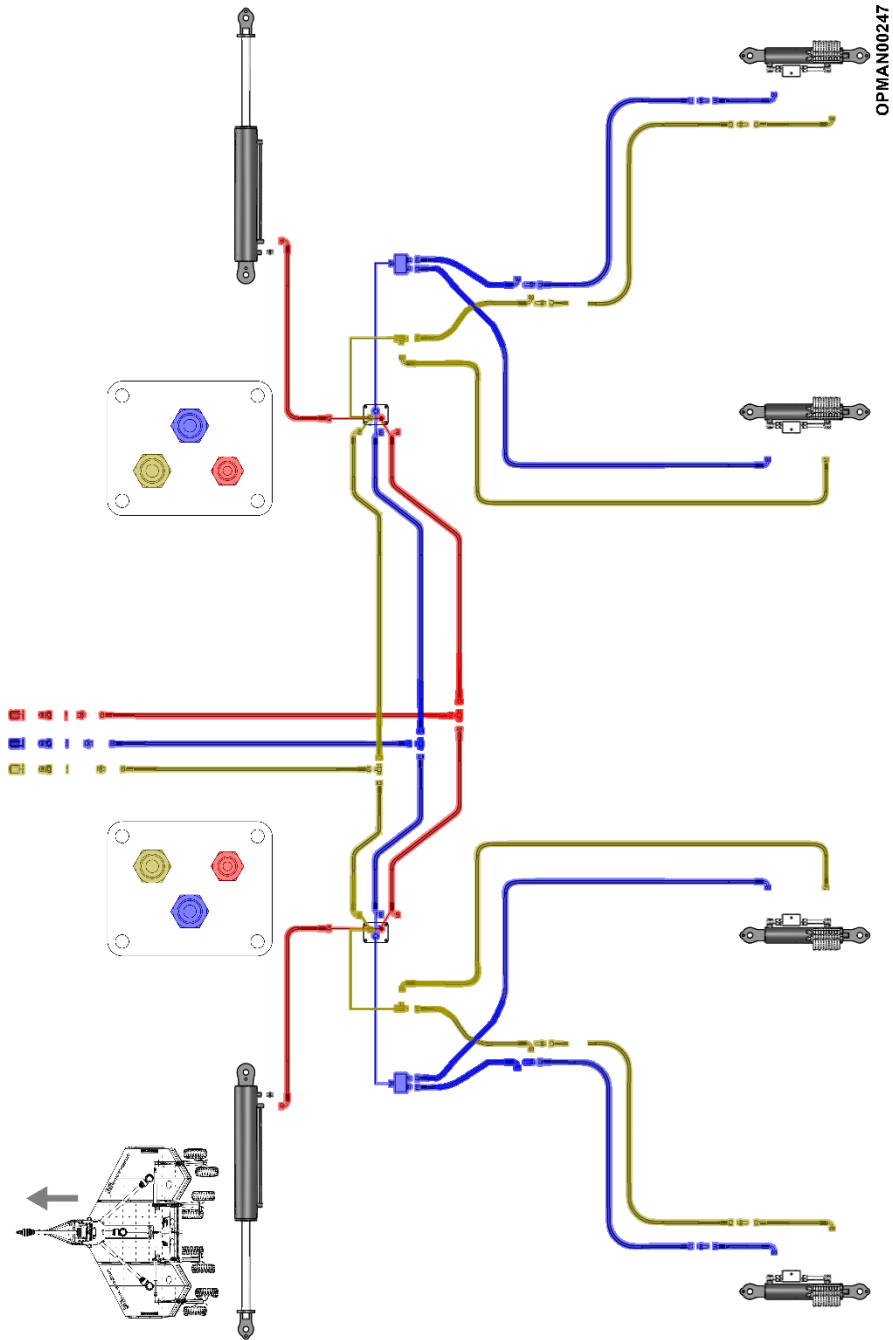

Figure 5.71 – Stubble Master 500/730 Hose Diagram

5.7 Wheels, Hubs & Tyres



Equipment Required

- Torque wrench (see required settings in Torque Settings section)
- 24mm hex sockets/spanner

Before installing/removing any wheels and tyres make certain that the machine is jacked up high enough for them to be easily fitted and to ensure that the machine is securely supported with fixed supports so it cannot move.

When installing any of the various Stubble Master wheel options ensure that the **domed side of the lug nut is against the wheel**; see Figure 5.73.

When installing any of the various Stubble Master wheel options ensure that the **flat of the wheel face is against the hub face**; see Figure 5.73.

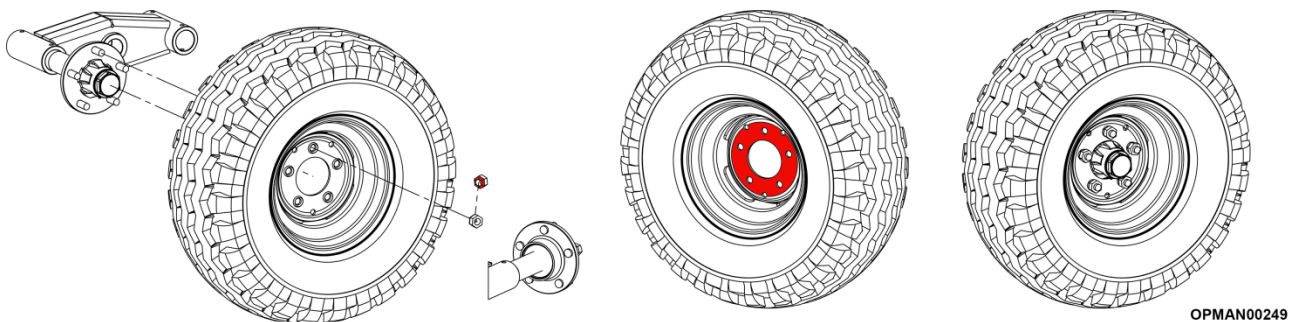

Figure 5.73 – Stubble Master Wheel & Wheel Nut Orientation

When making reference to the “split” wheel options shown in Section 1.5.2.3; namely the:

- Forklift truck tyre

It is important when removing these wheels to ensure that the **wheel/hub nuts are loosened; rather than the split rim nuts** so the wheel rim doesn't split apart during work/transport to and from the work site; causing danger to the operators, bystanders and the machine. See Figure 5.74 for guidance for the correct nuts to loosen.

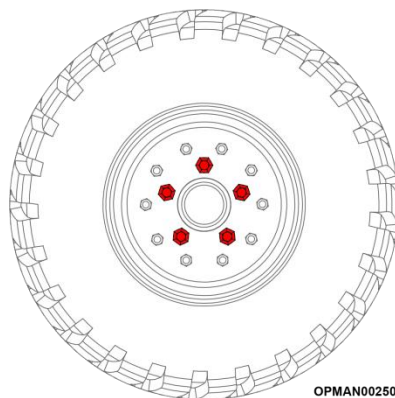



Figure 5.74 – Stubble Master Forklift Truck Tyre Wheel Nuts To Loosen

The Implement tyres (standard and aramide) feature a single piece rim, so do not need this level of caution; however hub bolt fixing torques should be adhered to. For torque settings; see Section 5.9.

IMPORTANT: Do not use any other wheel/tyre than those recommended/supplied by Spearhead. Spearhead declines all responsibility for damage and/or injury caused by use of **anything** other than the wheels/tyres which are supplied with the machine as new or sold as a spare part replacement sold by a Spearhead dealer on Stubble Master machines. **If you are unsure of the correct wheel/tyre for the machine,** or need additional assistance, please **contact your local Spearhead dealer, qualified service centre or Spearhead.**

5.7.1 Tyre Pressures

	Equipment Required
	<ul style="list-style-type: none"> Air supply with Schrader valve

Tyre pressures should be **checked weekly** and when they're cold to ensure their longevity and wellbeing as well as the safety and stability of the machine in use and to ensure level cutting when the machine is in work.

Machine Model.	Tyre Type.	Tyre Pressure.
Stubble Master 500/730	Implement/Aramide Implement	29 psi/2 bar
	Forklift Truck Tyre	40 psi/2.75 bar

Table 5.18 – Stubble Master Tyre Pressures

5.7.2 Hub Greasing

	Equipment Required
	<ul style="list-style-type: none"> Manually operated grease gun supplying NLGI #2 Molybdenum Disulphide Grease to M6/M8 grease nipples

Spearhead Stubble Master wheel hubs feature grease nipples which **need to be greased at least once a week** (dependant on amount of machine use). They are found on all hubs shown in the position on Figure 5.75.

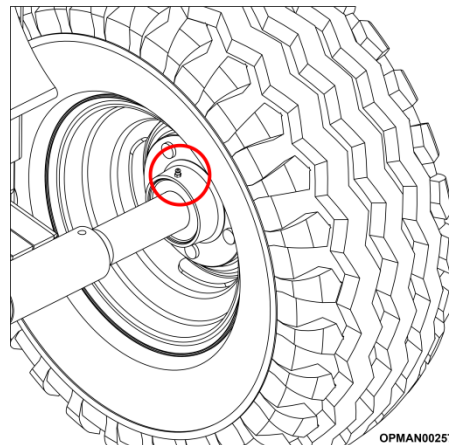

Figure 5.75 – Stubble Master Wheel Hub Greasing Location

5.7.3 Maximum Road Operating Speed

The various tyre options available on Stubble Master machines are designed to operate at a **maximum of 20 mph (32 kmh)**. Ensure before proceeding to take the machine onto the public highway, ensure that the wheel/tyre fitted to the machine is suitable for road use. **Do not exceed 20 mph (32 kmh) on any tyre option** and drive with compliance to the Highway Code (or other local driving authority/body) and road conditions.

5.8 Other Key Components



IMPORTANT: Before starting, safety checks on tractor and machine must be carried out with regard to: functionality, road safety and accident prevention rules.

5.8.1 Pins & Bushes

Pins

Pins should be inspected regularly to ensure they are not worn, damaged or loose.

Ensure all pins and accompanying fasteners are tight and routinely checked following the guidance given on the Maintenance Sheet; see Section 5.10.

Ensure that the pins have not been worn in such a way to create a step. Make sure the pin is not bent and the head is not damaged. If in any doubt, replace.

Bushes

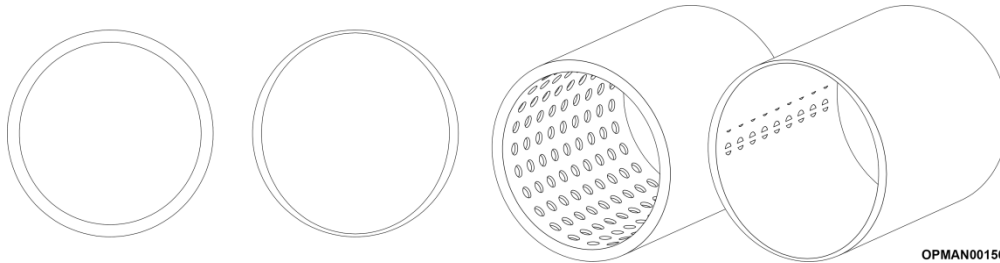

Figure 5.76 – New & Worn Bush Comparison

The machine should be inspected regularly to ensure the bushes are not worn. Worn bushes should be replaced when there is excess movement. Bushes will wear oversize or oval with indication on the interior showing the oil galleries being worn away. To prevent premature wear grease the bushes (where applicable) following the greasing schedule; see Section 5.2.4.

5.8.2 Skids



Equipment Required

- 19mm allen head socket/key
- 17mm hex socket/spanner

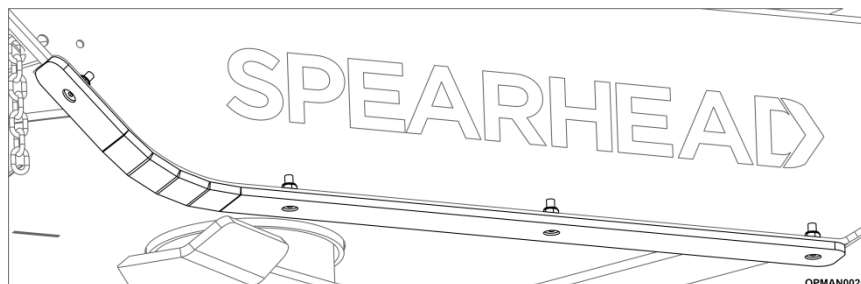

Figure 5.77 – Stubble Master Wing Skid

Spearhead machine skids are fitted to protect the machine deck fabrications from permanent damage. Premature wear can be caused to the skids through the machine being set too low, allowing the skids to drag along the ground causing an earlier requirement for replacement. Dragging the skids on the ground or running the skids into solid objects can contribute to early frame failure of the machine. Replace worn skids as required. **Failure to replace skids and using the machine without will cause permanent damage to the deck fabrications.**

5.9 Torque Settings

5.9.1 Nuts & Bolts

Specific Fastener Requirements

On Stubble Master machines, there are some special fasteners/components which require specific torque settings to ensure they operate safely.

Use	Machine	Size	Grade	Torque Setting	
				Nm	Ft-lb
Gearbox Bolts	All	M16	8.8	280	206
Blade Bolts	All	M24	8.8	540-800	398-590
Axle Bolts	All	M24	12.9	1500	1106
Wheel Nuts	All			270	199

Table 5.19 – Stubble Master Specific Fastener Torque Settings

Non-specific Fastener Requirements

The below tables give reference to the **maximum** recommended tightening torques for standard, zinc plated finished bolts on Spearhead machines. **These settings can be applied to hex, socket countersunk and socket button screws.**

Size	Grade					
	8.8		10.9		12.9	
	Nm	Ft-lb	Nm	Ft-lb	Nm	Ft-lb
M5	5	3	7	5	8	6
M6	14	10	12	9	14	10
M8	34	25	29	21	34	25
M10	68	50	57	42	68	50
M12	119	88	99	73	119	88
M14	189	139	158	116	189	139
M16	295	218	246	181	295	218
M18	406	299	338	249	406	299
M20	576	424	480	354	576	424
M22	783	577	652	481	783	577
M24	995	734	829	612	995	734
M30	1977	1458	1647	1215	1977	1458

Table 5.20 – Standard Fastener Torque Settings

5.9.2 Hydraulic Fittings

Throughout all Stubble Master machines, BSP adaptors and hoses are used. See the relevant headings for adaptors and hoses.

Port Adaptors With Bonded Seals

The below tables give reference to the **maximum** recommended tightening torques for standard, BSP port adaptors found on Stubble Master machines.

Size	Thread	Torque Setting		Spanner Size
		Nm	Ft-lb	
1/4"	BSP	34	25	19mm
3/8"	BSP	47	35	22mm
1/2"	BSP	102	75	27mm

Table 5.21 – Stubble Master Adaptor Torque Settings

Hydraulic Hoses

The below tables give reference to the **maximum** recommended tightening torques for standard, hydraulic hoses on Stubble Master machines.

Size	Thread	Torque Setting		Spanner Size
		Nm	Ft-lb	
1/4"	BSP	18	13	19mm
3/8"	BSP	31	23	22mm

Table 5.22 – Stubble Master Hydraulic Hose Torque Settings

5.10 Machine Inspection Record

	MACHINE INSPECTION RECORD (For Stubble Master 500/730)	Pre-delivery inspection:	Select
		Installation inspection:	Select
		Daily pre-work inspection:	Select
Model:	Serial No:		
Inspector name (print):	Inspection date:		
Company/Position:			
Inspector signature:			
Visual Checks		Comments	OK
Check that an operator's instruction manual in the correct language for the working territory is in the machine document holder.			
Check that the operator's instruction manual is filled in and serial number is present and matches the serial number of the machine.			
Warning decals are present, clean and in good order			
Inspect main fabrications and damage – decks, axles, drawbar e.t.c.			
Inspect all hosing for damage – kinks, twists chafing or weeping			
Ensure hydraulic hoses are routed to tractor through the hose guide			
Inspect all hydraulic rams for damage and oil leaks			
Inspect all hydraulic ram breathers are present			
Inspect all lighting on the machine to ensure it is operating correctly			
Inspect to see all warning decals are present, legible and clean			
Inspect PTO shaft and cone guards for integrity and condition			
Inspect to see all protection chains are present			
Inspect to see all fixed guarding protection is present			
Ensure that each of the axle rams have an equal amount of spacers inserted to ensure safe machine operation and a level cut			
Ensure when fitting the machine to the tractor that a wear pad is placed between the towing eye and hitch of the tractor			
Ensure when fitting the machine to the tractor that the safety chain is fitted between the tractor and drawbar			
Inspect blade condition against the operator's manual guidance			
Inspect that the correct blades are fitted for the given rotor direction against the operator's manual			
Inspect blade carrier anti-scalp dish condition against the operator's manual guidance			

Mechanical Checks	Comments	OK
Check all hydraulic hoses and adaptors for tightness and tighten to the correct torque setting given in the operator's instruction manual		
Ensure the oil gearbox quantity is to the level plug on each gearbox. Consult the maintenance schedule to see whether an oil change is scheduled		
Ensure the gearbox breather are present and free from dirt		
Check the gearbox mounting fasteners are tight to the correct torque setting given in the operator's instruction manual		
Randomly test for loose nuts and bolts. Tighten to manual settings		
Check all clutch settings against operator's manual values		
Check driveshaft retaining bolts torque setting against operator's manual values		
Grease all grease points in accordance with the operator's manual		

Inspect the skids for condition and tightness of its fasteners		
Check that the input PTO shaft is correctly seated at both the tractor and machine end		
Ensure the PTO retaining chain is fitted stopping guard rotation		
Inspect each of the PTO bearing wear rings for wear		
Ensure the towing eye is angled correctly with the guidance given in the operator's manual		
Check machine tyre pressures against the operator's manual		
Check tractor tyre condition and pressures against the tractor operator's manual		
Check wheel nut tightness against operator's instruction manual		
Check wheel bearings for play and movement		
Ensure the tie bar is adjusted correctly so the front and rear of the machine are setup correctly. See operator's manual for guidance		
Ensure retention strap is fitted for transport		
Tractor spec meets spec requirement of the machine (PTO rpm/HP)		
Inspect blade bolts for condition and tightness against operator's manual torque values		
Ensure that the blades are free-swinging		

Running Checks	Comments	OK
Once all visual and mechanical checks have been made, follow the running checks below		
Pressurise hydraulic rams and inspect for leaks		
Check wings lower unaided		
Fully raise and lower the machine, checking for pinch points on the chassis		
Run the machine to operating speed to check for vibration. If vibration is present check the "Troubleshooting" section in the operator's manual		
Check for excess noise and heat build-up in components		

Other comments:

Disclaimer: All guidance and maintenance advise to be carried out on the machine as written in this inspection record is deemed on the provision that the operator/maintenance operative has fully read and understood the specific operators manual for the given model of machine and follows the guidance and safety precautions described within it.

Spearhead claims no responsibility to any machine and/or physical harm caused by anything other than the practice guidelines stated in its specific machine model operators manual.

Spearhead Machinery Ltd
Station Road, Salford Priors, Evesham, Worcestershire, WR11 8SW, England
Tel: +44 (0)1789 491860

5.11 Machine Storage

Follow the following sections for guidance to correctly storing Stubble Master machines out of working use and preparing back into correct working condition.

5.11.1 Preparing The Machine For Storage

Following seasonal use it is important to prepare the machine for storage, thinking of the preservation of parts condition and ease of reintroduction when bringing the machine back into work after periods of no use.

Follow the following points:

5.11.1.1 Thoroughly wash the machine removing all traces of grass and dirt.

Great care should be taken when using pressure washers. **Do not** hold the pressure washer lance close to the paintwork and items containing seals as this can cause damage and discolouration.

Spearhead does not recommend using steam cleaners.

5.11.1.2 Unload the spring tension out of slip clutch assembly to free the clutch plates, to ensure they do not seize.

At this point check the condition of the friction plates, if there is any sign of overheating, wear or cracking; replace with new.

5.11.1.3 Remove and store the input PTO shaft and splitter/centre rotor gearbox coupling.

5.11.1.4 Inflate tyres (including wing tyres) to the correct pressure as stated in Section 5.7.1.

5.11.1.5 Grease all grease points following the guidance given in Section 5.2.3 and 5.2.4.

5.11.1.6 Liberally place oil along the complete length of each of the wing hinges.

5.11.1.7 Liberally smear grease along the length of exposed plated hydraulic ram shafts and any other exposed threaded item.

5.11.1.8 Tighten all fasteners, pins and hoses to the recommended torque.

5.11.1.9 Use touch up paint available from Spearhead where necessary to preserve the appearance of the machine.

5.11.1.10 Ideally store the machine in the dry indoors, on a firm surface or stands, away from the elements. This will greatly preserve the machines physical appearance and condition.

It is also best practice to inspect the machine for worn/damaged items which will be required to be replaced before entering work again in the new season. Consult the maintenance schedule for the machine (Section 5.10) as well as other specific maintenance task sections to see what could be required to be done to the machine.

Ordering replacement parts at the beginning of this period with plenty of time will potentially reduce the delays of reintroduction into work with out of stock items. Many other local operators will be carrying out the same procedure at the same time.



OPMAN00182

Figure 5.78 – Prepare For Storage

Where parts are broken, damaged and deemed not fit for use; replace with genuine Spearhead parts using the online Interactive Parts facility at

<https://my.spearheadmachinery.com/parts/public-interactive-parts-database/>

You will require the machine serial number. Assistance to its location can be found in Section 1.3.

Spearhead Stubble Master flex wing mulchers are designed to withstand the most rigorous conditions and with a little care and attention will give many years of trouble free service. So as not to invalidate the warranty and to avoid problem, use only genuine Spearhead parts and make sure the machine is not driven at a speed in excess of 1000 rpm on the PTO.

5.11.2 Returning The Machine Back To Work

Returning the machine back to work, in most cases, is similar to preparing the machine for storage shown in Section 5.11.1. If the procedure shown in that section is adhered to, a lot of the preparation work will have already been done to quickly reintroduce the machine back into work condition.

Follow the following points:

- 5.11.2.1 Depending on the period of the machine being unused and whether the machine has been stored outside, the machine may require cleaning.

Great care should be taken when using pressure washers. **Do not** hold the pressure washer lance close to the paintwork and items containing seals as this can cause damage and discolouration.

Spearhead does not recommend using steam cleaners.

- 5.11.2.2 Disassemble each of the machine clutches and with emery cloth remove all traces of rust on the metal clutch plates (if present). Reset the spring tension on each of the slip clutches following the guidance shown in Section 5.4.

Check the condition of the friction plates, if there is any sign of overheating, wear or cracking; replace with new. Do not attempt to use the machine with damaged slip clutch plates.

- 5.11.2.3 Fit the input PTO shaft and splitter/centre rotor gearbox coupling following the guidance given in Section 3.4.1 and torque the taper pin to 230Nm (170 ft/lbs).

- 5.11.2.4 Inflate tyres (including wing tyres) to the correct pressure as stated in Section 5.7.1.

- 5.11.2.5 If not carried out before storage, grease all grease points following the guidance given in Section 5.2.

- 5.11.2.6 If not carried out before storage, tighten all fasteners, pins and hoses to the recommended torque.

- 5.11.2.7 Remove the smeared grease found along the length of exposed plated hydraulic ram shafts and any other exposed threaded item which were put on during the storage period.

- 5.11.2.8 Carry out a full machine inspection, using the Machine Inspection Record guide sheet found in Section 5.10.

Where parts are broken, damaged and deemed not fit for use; replace with genuine Spearhead parts using the online Interactive Parts facility at:

<https://my.spearheadmachinery.com/parts/public-interactive-parts-database/>

You will require the machine serial number. Assistance to its location can be found in Section 1.3

Spearhead Stubble Master flex wing mulchers are designed to withstand the most rigorous conditions and with a little care and attention will give many years of trouble free service. So as not to invalidate the warranty and to avoid problem, use only genuine Spearhead parts and make sure the machine is not driven at a speed in excess of 1000 rpm on the PTO.

6 Troubleshooting

	Symptom	Possible Cause	Remedy
6.1	Irregular cut	a) Worn, bent or broken blades	Replace blades immediately. <ul style="list-style-type: none"> • Raise cutting height to avoid striking objects • Remove/avoid obstacles such as rocks • Check rotor speed • Ensure steady initial starting of the machine
		b) PTO input speed too slow	Check PTO input speed and increase to maximum indicated; see Section 2.5.1
		c) Machine is not level to the ground	Level the machine front to rear and left to right. See Section 4.7.1 and Section 4.7.2
		d) Clogged material due to excessive ground speed	Reduce tractor speed over ground and check correct PTO input speed
		e) Unequal quantity of spacers in axle rams	Ensure that all axle hydraulic rams have an equal quantity of spacers inserted
6.2	Machine noise	a) Loose bolts	Check and tighten to the correct torque. See Section 5.9
		b) Damage to a fabrication or cracks	Repair fabrication in specialised, approved workshop or replace component with genuine part
		c) Vibration	See "Vibration" symptom heading below
6.3	Gearbox noise	a) Lack of oil	Fill to level mark on gearbox
		b) Worn gears	Replace gears with genuine Spearhead part
		c) Worn bearings	Replace bearings with genuine Spearhead part
6.4	Vibration!	a) Lost/broken blades (see 6.5)	Replace all blades on that rotor
		b) Bent gearbox rotor	Replace gearbox shaft and seals
		c) Worn gearbox bearings	Replace bearings and seals
		d) PTO speed too high	Reduce PTO speed to the correct operating speed
6.5	Broken/damaged blades	a) Blades struck object	Raise cutting height to avoid striking objects again Remove/avoid obstacles such as rocks
		b) PTO going too fast	Reduce PTO speed to the correct operating speed
		c) Blades sped up too quickly	Ensure a steady engagement into driving the PTO with a low tractor engine speed
		d) Excess play in blade mounting	Worn blades bushes. Bolts loose, tighten to torque setting as stated in Section 5.9.
6.6	Damaged/worn blade carrier	a) Blade carrier struck object	Raise cutting height to avoid striking objects again Remove/avoid obstacles such as rocks
		b) PTO going too fast	Reduce PTO speed to the correct operating speed
		c) Blade carrier sped up too quickly	Ensure a steady engagement into driving the PTO with a low tractor engine speed
		d) Excess play in blade mounting	Worn blades bushes. Bolts loose, tighten to torque setting as stated in Section 5.9
		e) Failure to keep tight centre retaining nut	Tighten nut and secure with split pin
6.7	Damaged gearbox	a) Seized slip clutch	Free slip clutch by following the guidance in Section 5.4.2 and reset clutch settings to the correct setting following Section 5.4.3
		b) PTO shaft telescopic guard bottoming out	Shorten the telescopic following the guidance in Section 3.3.4
		c) Engaged PTO drive with too much speed	Ensure a steady engagement into driving the PTO with a low tractor engine speed
		d) Lack of grease on sliding tubes of drive shaft	Remove and split the PTO shaft following guidance in Section 5.3 and grease the two halves

6.8	Gearbox overheating	a) Incorrect oil level	Fill to level mark on gearbox
		b) Incorrect grade of oil	Drain existing oil and refill using EP80/90W or GL-4/GL-5
		c) Incorrect operating speed	Operate the PTO speed at the correct speed as stated on the decal on the splitter gearbox
		d) Machine overloaded	Reduce tractor/machine forward speed
		e) Build-up of material around the gearbox	Stop the machine. Being careful of heat, clear the material around the gearbox
6.9	Damage to PTO shaft	a) Seized slip clutch	Free slip clutch by following the guidance in Section 5.4.2 and reset clutch settings to the correct setting following Section 5.4.3
		b) PTO shaft telescopic guard bottoming out	Shorten the telescopic following the guidance in Section 3.3.4
		c) Engaged PTO drive with too much speed	Ensure a steady engagement into driving the PTO with a low tractor engine speed
		d) Turning the machine too sharply	Avoid turning the machine too tightly. See Section 4.10 on the guidance to correctly driving the machine
		e) Not enough overlap	Purchase another input shaft and cut to the correct length (to give sufficient overlap) following the guidance given in Section 3.3.4
		f) Lack of grease	Grease various locations on the shaft following the guidance given in Section 5.3.2
		g) Build-up of material under drive shaft	Stop the machine. Being careful of heat, clear the material under the drive shaft
6.10	Slip clutch overheating	a) Machine overloaded	Reduce tractor/machine forward speed
		b) Incorrect operating speed	Operate the PTO speed at the correct speed as stated on the decal on the splitter gearbox
		c) Incorrect clutch setting	Reset clutch settings to the correct setting following Section 5.4
		d) Blades hitting the ground	Raise cutting height to avoid striking objects and/or remove/avoid/mark obstacles such as rocks
6.11	Gearbox oil leak	a) Damaged output shaft oil seal	Inspect the gearbox seal protector for foreign material (e.g. wire). Remove and replace oil seal
		b) Faulty breather	Remove the breather and clean or replace
		c) Damaged gasket	Remove the covering plate/housing and replace gasket
		d) Incorrect oil level	Fill to level mark on gearbox
6.12	Metal fatigue on fabrication	a) Too fast working/transportation speed	Slow down! See Section 4.10 on the guidance to correctly driving the machine correctly in work and during transportation
		b) Machine wings aren't floating and following the ground contours correctly	Check tractor spool
		c) Used in a poor manner/condition	See Section 4.10 on the guidance to correctly driving the machine correctly in work and during transportation. See Section 5 on the guidance to correctly maintaining the machine
6.13	Excessive skid wear	a) Running the machine too low	Adjust the machine to the correct height following the guidance in Section 4.8.

7 Spare Parts

7.1 How To Obtain The Correct Spare Part Numbers

For correct part numbers; use the Spearhead interactive online parts books. These are available at <https://my.spearheadmachinery.com/parts/public-interactive-parts-database/>. You will need to enter the machine serial number; see Figure 1.4.

7.1.1.1 Enter the serial number.

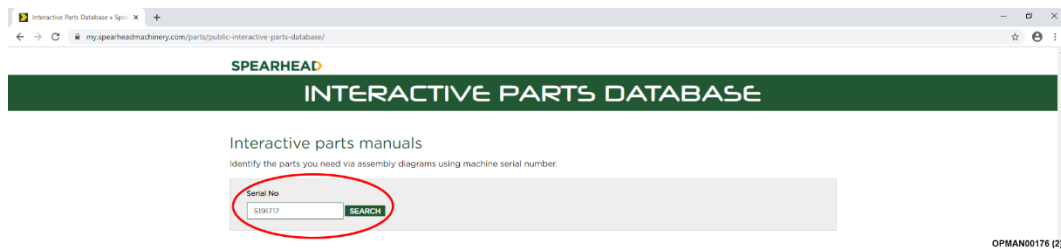

Figure 7.1 – Type In Serial Number

7.1.1.2 After entering the serial number a specification for the machine will appear. Click on the serial number; see Figure 7.2.

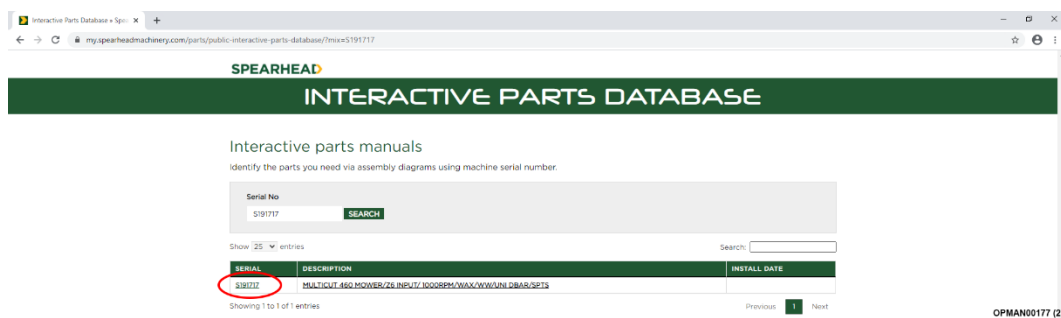

Figure 7.2 – Click On Serial Number

7.1.1.3 After clicking on the serial number a full parts breakdown, specific to the machine serial number will appear showing the various parts and assemblies of the machine. Click on the specific assembly picture required; see Figure 7.3.

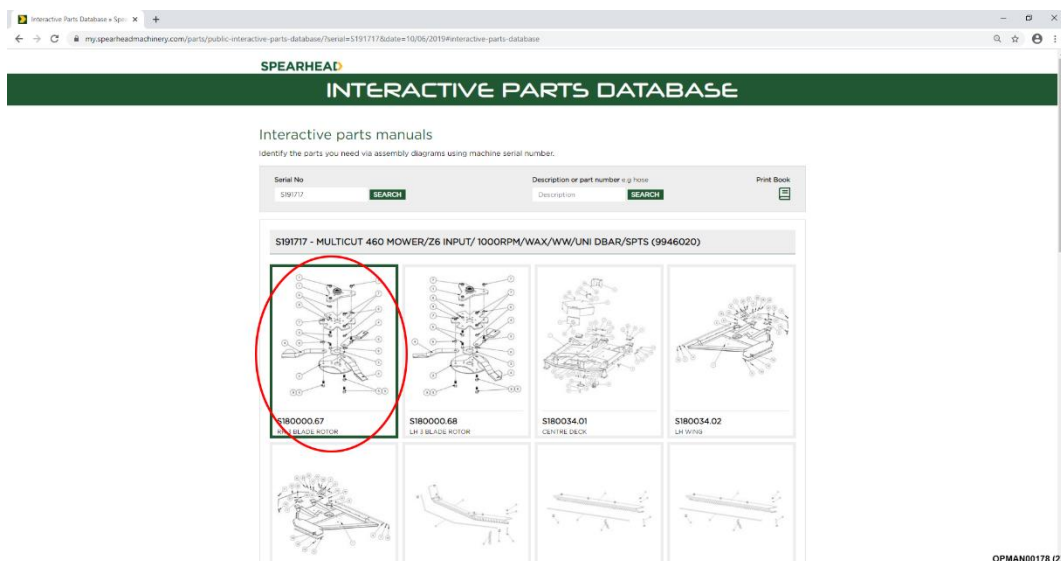

Figure 7.3 – Click On Assembly

- 7.1.1.4 You will finally be presented with a full exploded parts breakdown for that particular assembly, giving part numbers and the quantities required; see Figure 7.4.

The screenshot displays the 'INTERACTIVE PARTS DATABASE' interface. It features a search bar with 'Serial No' and 'Description or part number' fields. Below the search bar is a table titled 'Print Part List and diagram' with the following data:

Ref	Part No	Description	QTY
1	1770602-342	CHIM BLADE CARRIER UPPER (102)	1
2	1770609	LOWER BLADE CARRIER (102)	1
3	1770604-3	SPACER	1
4	7770700	BLADE - RH C/W PIN 25	3
5	277045	BOLT	6
6	7770707	BLADE BUSH	6
7	277044	NUT	6
8	046053	CARRIER	1
9	2770464	WASHER	2

To the right of the table is an exploded view diagram of the assembly, with numbered callouts (1-9) corresponding to the parts in the table. The interface also includes a 'Print Book' button and a 'Serial No' field with the value '59177'.

Figure 7.4 – Exploded Parts Breakdown With Bill Of Materials

7.2 Spare Parts Ordering

It is important to note that when it comes to ordering replacement parts, that this can **only** be carried out through a Spearhead dealer. **Spearhead does not accept direct customer parts orders over email, fax or telephone.**

For guidance on finding your local Spearhead dealer; see Section 7.3.

7.3 Dealer Network

Spearhead has an extensive dealer network which can offer genuine replacement parts.

In order to make it easier to find your local Spearhead dealer, the Spearhead website has a Dealer Locator facility.

<http://www.spearheadmachinery.com/dealer-locator/>

To find your local Spearhead dealer enter your location or postcode into the “Your location” box and then press “Search”; see Figure 7.5.

The screenshot shows the 'DEALER LOCATOR' page on the Spearhead website. The search bar contains 'Evesham' and the search radius is set to '25 mi'. The results show 23 dealers. A map of the United Kingdom is displayed, with a green circle indicating the search radius centered on Evesham. The map also shows other countries like Ireland, Denmark, Netherlands, and Germany.

Figure 7.5 – Dealer Locator

Notes

Notes