

**Spearhead Machinery
Operator Instruction Manual For**

DESTROYER FLAIL

2.00m cut width, 540 or 1000 PTO input

Vegetation control forestry mulcher

8999124EN v2.1

IMPORTANT

Verification Of Warranty Registration

Dealer Warranty Information & Registration Verification

It is imperative that the selling dealer registers this machine with Spearhead before delivery to the end user.

Failure to do so may affect the validity of the machine warranty.

To register machines go to the Spearhead Machinery Limited web site at:

<https://my.spearheadmachinery.com/warranty/machine-registration/>

Should you experience any problems registering a machine in this manner please contact the Spearhead Service Department on 01789 491860.

Confirm to the customer that the machine has been registered in the section below.

Registration Verification

Model Type:		Destroyer Flail
Model Number:		99 _____
Serial Numbers:	Machine:	S _____
	Cutting Implement:	S _____
	Other:	
Name Of Owner:		
Name Of Installing Dealer:		
Dealer Address:		
Dealer Signature:		
Date Of Delivery / Installation:		
Date Of Warranty Registration:		

IMPORTANT

At the point of transfer of ownership record the above information. Note the serial number of your machine and always quote it in any communication with us or your dealer. (The serial number plate is located on the machine mainframe.) This is particularly important when ordering spares. Remember to include all numbers and letters.

The information given throughout this manual is correct at the time of publication. However, in the course of constant development of Spearhead machines, changes in specification are inevitable. Should you find the information given in this book to be at variance with the machine in your possession, you are advised to contact the Spearhead Service department where up-to-date information will be provided.

The manual can contain standard and optional features and is not to be used as a machine specification. The machine has been tested and is considered safe if carefully used. Ensure your operator is properly trained in its use and maintenance.

(This page is left blank intentionally)

Destroyer Flail Flail Mulcher

This manual contains the instructions for installation, use and maintenance of the Destroyer Flail 200F Flail mulcher hereafter more simply called the "Mulcher."

The Mulcher is designed and built to mulch branches, overgrown vegetation and logs up to 18 cm in diameter. Any different use should be considered improper and therefore potentially dangerous to the safety of the operator and any exposed persons. This manual is integral to the Mulcher, defines the purpose for which it was built and contains all the information required for proper and safe use.

Regular machine operation depends on its correct use and adequate maintenance: it is advisable, therefore, to follow these instructions carefully to prevent any situation that could compromise the machine's operation and durability. It is also important to follow that which is described in this manual since Spearhead declines any liability resulting from negligence of from not observing these norms, since it would result in the warranty being annulled.

It is mandatory to verify upon delivery that the mulcher is integral and complete in all its parts. Any complaints must be presented in writing within 8 (eight) days from receiving the machine. Spearhead can however be contacted at any time for immediate and precise technical assistance and anything required for optimum operation and maximum performance of the equipment. Upon receiving the product, carefully read the manual and carefully follow the instructions contained in it.

IMPORTANT

This operator's manual should be regarded as part of the machine. Suppliers of both new and second-hand machines are advised to retain documentary evidence that this manual was provided with the machine.

This machine is designed solely for ground vegetation control and must not be used for any other purpose. Use in any other way is considered as contrary to the intended use. Compliance with, and strict adherence to, the conditions of operation, service, and repair, as specified by the manufacturer, also constitute essential elements of the intended use.

This machine should be operated, serviced, and repaired only by persons who are familiar with its characteristics and who are acquainted with the relevant safety procedures.

Accident prevention regulations, all other generally recognised regulations on safety and occupational medicine, and all road traffic regulations must always be observed.

Any arbitrary modifications carried out to this machine may relieve the manufacturer of liability for any resulting damage or injury.

It is potentially hazardous to fit or use any parts other than genuine **Spearhead** parts.

The company disclaims all liability for the consequences of such use which, in addition, voids the machine warranty.

(This page is left blank intentionally)

Contents List

1	Description and Main Characteristics	8
1.1	Mulcher Description	8
1.2	Intended Usage	9
1.2.1	Allowed Uses	9
1.2.2	Improper Uses	9
1.3	Machine Identification	9
1.4	Technical Data	10
1.5	Sound Level	10
2	General Safety And Accident Prevention Standards	12
2.1	Level Of Danger	12
2.2	Terminology	12
2.3	Danger Plates And Warning	14
2.3.1	Proposition 65	16
2.4	Clothing	17
2.5	Ecology And Pollution	17
2.5.1	Disposal	17
2.5.2	Storage	17
2.6	Safe Use	18
2.7	Safe Maintenance	19
3	Installing The Mulcher	20
3.1	Delivery	20
3.2	First Use	21
3.2.1	Prior To Installation	21
3.2.2	Application To The Tractor	21
3.2.3	Input PTO Shaft	22
4	Usage Instructions	26
4.1	Before Use	26
4.2	Machine Settings	27
4.2.1	Adjustment Of The Skids And Roller	27
4.2.2	Adjustment Of Working Height	28
4.3	Using The Mulcher	28
4.4	After Use	30
4.5	Safety Devices	31
4.6	Machine Transport Procedure	32
5	Maintenance	34
5.1	Periodic Maintenance	35
5.1.1	Maintenance On The Teeth	35
5.1.2	Belt Maintenance	36
5.2	Clutch Settings	37
5.3	Cleaning The Mulcher	38
5.4	Lubricants	38
6	Troubleshooting	40
7	Spare Parts	42
7.1	How To Obtain The Correct Spare Part Numbers	42
7.2	Spare Parts Ordering	43
7.3	Dealer Network	43

(This page is left blank intentionally)

1 Description and Main Characteristics

1.1 Mulcher Description

With reference to Figure 1, the mulcher is a machine designed and built exclusively for mulching operations directly on the field. It shreds plant remains, allowing you to mulch branches, overgrown vegetation and logs. It must not be used for other uses or with other materials. The mulcher consists of the following parts:

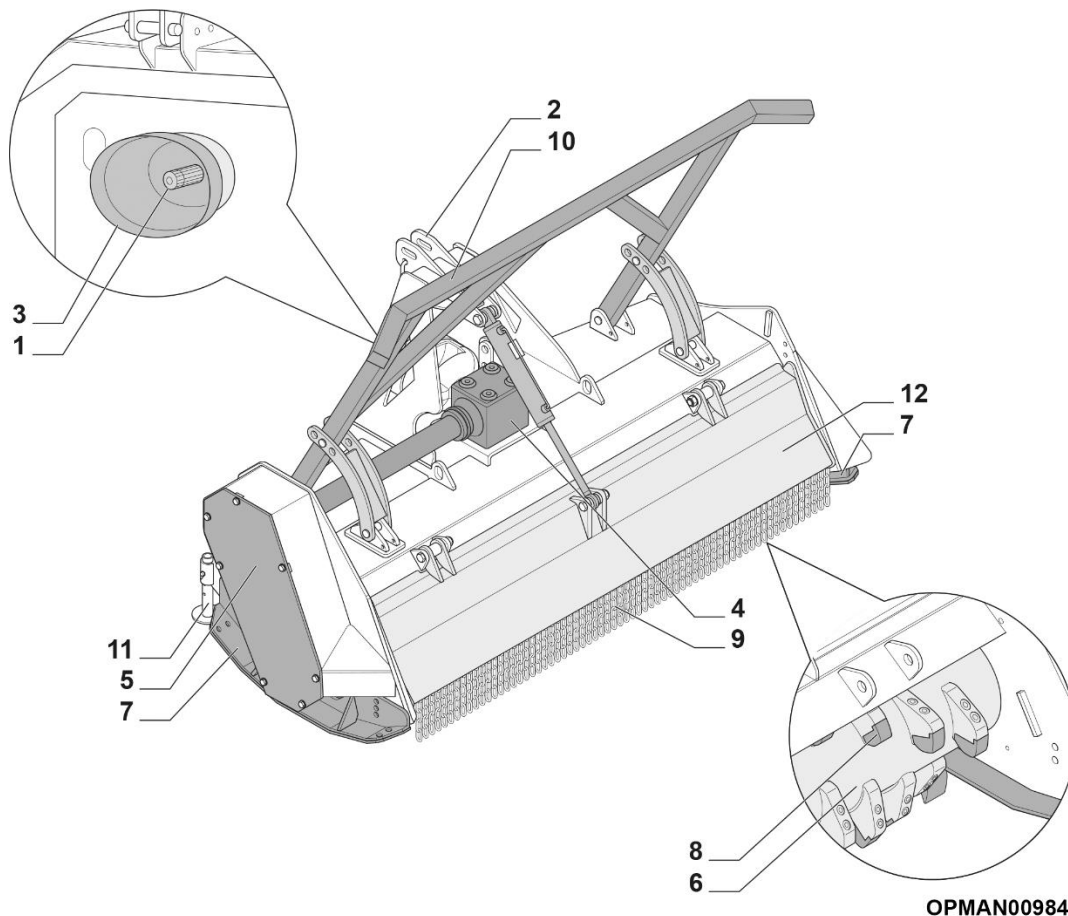

Figure 1

Item No.	Description
1	Input PTO
2	Headstock
3	Input PTO Protection Cone
4	Gearbox
5	Belt Guard Cover
6	Rotor Shaft

Table 1

Item No.	Description.
7	Skid
8	Cutting Tooth
9	Protection Chains
10	Push Frame (Manual)
11	Stand
12	Rear Opening Hood

1.2 Intended Usage

1.2.1 Allowed Uses

The mulcher is designed and built to mulch branches, overgrown vegetation and trunks up to 18 cm in diameter.

When the mulcher works it guarantees the required level of safety even in the presence of an insignificant malfunction of its components or hazardous operating conditions, however, always within the permitted uses.

With reference to the above, the following are considered allowed uses:

- Using the mulcher to mow crop residue.

The mulcher must not be used for purposes other than those described in this manual.

1.2.2 Improper Uses

The mulcher, due to its typical construction, may also be suitable for uses other than from those foreseen by the manufacturer. For this reason Spearhead has selected, as non-exhaustive examples, a series of improper uses that can be reasonably foreseen, which are:

- Using the mulcher to mulch trunks with a diameter exceeding 18 cm;
- Using the mulcher to mulch or cut hedges;
- Using the mulcher for shredding purposes near frequented areas.

The uses listed above and those not specifically indicated in this manual, including reasonably foreseeable improper uses, are **strictly prohibited**.



Spearhead declines any and all liability for damages caused by the Mulcher to persons, animals or property, resulting from use other than that described in this manual, or due to damage caused by negligence or by not observing the instructions contained in this manual.

1.3 Machine Identification

Each machine is equipped with a serial plate; see Figure 2 that includes the following data in this order:

1. UKCA Conformity Marking.
2. Machine Whole Goods Code (WGC).
3. Serial number of the machine.
4. Mass in kg.
5. Production Year (year of construction).
6. Design conformity standard.
7. Machine Product Group Code.
8. EU Authorised Representative QR scan code.
9. Manufacturer marking with name and address.
10. EAC Eurasian/Russian Conformity Marking.
11. EC European Conformity Marking.
12. Product Group Code.

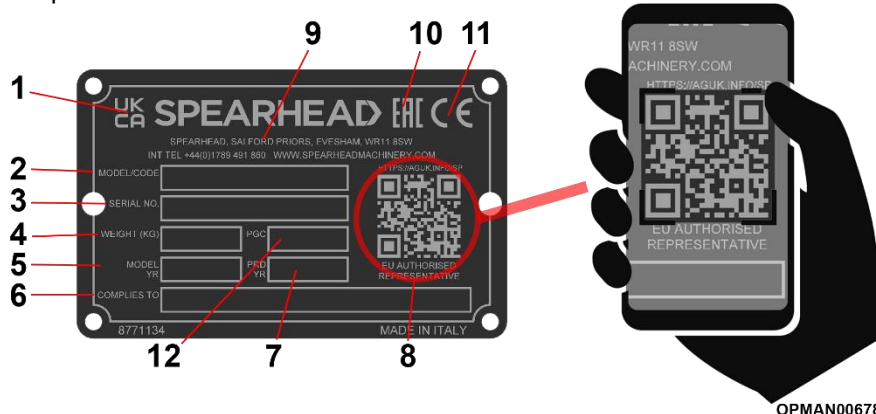

Figure 2 – Serial Plate

Data on the Spearhead manufacturer's plate should always be referred to when requesting assistance and/or requiring replacement spare parts.

This data can identify the machine and its characteristics and specification for its particular time of manufacture, certifying that it responds to current regulations. For this reason the plate should never therefore be removed nor be used for other purposes; if the machine is dismantled, it should be destroyed to prevent any form of abuse.

By utilising a smart phone and scanning the Authorised Representative QR scan code found on the right-hand side of the serial plate (ref 8, Figure 2) using a suitable QR scanning App, you can find details for Spearhead Machinery authorised representatives for its various territories.

1.4 Technical Data

Model	Working Width (cm)	Minimum Tractor HP Requirement	Number of Teeth	Weight (kg)	Dimensions (W x L x H) cm
Destroyer Flail 200F	190	80	60	1150	234 x 112 x112

Table 2

Hitch to the tractor	3-point universal
Hitch category	CAT 1-2
PTO input speed	540/1000 rpm
Primary transmission	Input Shaft
Secondary transmission	Belts
Cut height adjustment	Mechanical
Minimum tractor weight	See Section 4.6

1.5 Sound Level

The air noise level created by the Mulcher under operating conditions was detected using a sound level meter with integrator.

The measurements were carried out at the operator station with the Mulcher activated empty. Tests performed under the conditions indicated by the standard produced the following results:

Tractor with open cab:

Equivalent weighted sound pressure average level: $L_{pAm} = 80.7 \text{ dB(A)}$.

Tractor with closed cab:

Equivalent weighted sound pressure average level: $L_{pAm} = 78.8 \text{ dB(A)}$.

-Sound power level: $L_{wA} = 107.1 \text{ dB(A)}$.

(This page is left blank intentionally)

2 General Safety And Accident Prevention Standards

2.1 Level Of Danger

The safety of the operator and exposed persons is the main concern of the designer and the manufacturer of the machine. When designing a new machine, one tries to plan for all possible danger situations and risks connected to using the machine, adopting the steps necessary to make the equipment as safe as possible. **The number of accidents remains very high however, especially due to incautious and awkward use of the machine. It is therefore recommended to carefully read this manual and this section, regarding safety standards, avoiding behaviour that is inappropriate or in contrast with the instructions contained in this manual**

Pay attention to the following danger signal where contained in this manual and follow safety instructions.



DANGER! This signal warns that if the described operations are not carried out properly, they will cause serious injury, death or long-term health risks.



WARNING! This signal warns that if the described operations are not carried out properly, they may cause serious injury, death or long-term health risks.



CAUTION! This signal warns that if the described operations are not carried out properly, they may cause damage to the machine.

2.2 Terminology

The indicated levels of danger refer to specific risk situation that may occur during machine use and may involve the same machine, the operator and any exposed persons. With the purpose of highlighting situations or operations that may result in risks, the meanings of terms used in this manual are indicated here:

- **HAZARDOUS AREA:** Any area in and/or around a machine where the presence of an exposed person constitutes a risk to the health and safety of said person.
- **EXPOSED PERSON:** A person fully or partly in a hazardous area.
- **OPERATOR:** The person or personnel in charge of the installation, the operation, the adjusting, the cleaning, the repairing and the moving of the machine.
- **USER:** the person, entity or company, who purchased or rented the machine and intends to use it according to the intended use foreseen by the manufacturer.
- **SPECIALISED PERSONNEL:** any person specifically trained and approved to carry out maintenance or repair interventions that require particular knowledge of the machine, its operation, the installed safety devices, intervention modes. It must be capable of recognising danger present on the actual machine, therefore avoiding at risk situations.
- **RISK:** a combination of the probability and seriousness of injury or damage to health which can arise in a dangerous situation.
- **GUARD:** a part of the machine that is used to specifically guarantee protection by way of a material barrier.

- **PROTECTION DEVICE:** a device that reduces risk (unlike the guard) either on its own or together with the guard.
- **INTENDED USE:** the use of the machine in accordance with the information provided in the operator's manual.
- **REASONABLE FORESEEABLE MISUSE:** the use of the machine different to the information provided in the operator's instructions, which may be the result of readily predictable human behaviour.
- **GENUINE SPEARHEAD DEALER/ AUTHORIZED TRACTOR DEALER:** The Genuine Spearhead Dealer/ Authorized Tractor Dealer, legally authorised by the Manufacturer, is formed by specialised staff able to carry out all types of assistance, maintenance and repair work, even of a certain complexity, required to maintain the machine in perfect working order.



WARNING! Carefully read the following rules. If the instructions described are not followed, a situation may arise which causes irreparable damage to the machine or property, or injury – even severe – to people or animals.

Spearhead declines all responsibility for damage caused by not complying with the safety and injury prevention regulations described below. Spearhead also declines any responsibility for damage caused by improper use of the machine and/ or as a result of modifications made without authorisation by the manufacturer.

2.3 Danger Plates And Warning

The Mulcher is equipped with pictograms (labels) warning about residual risks present on the machine that it were not possible to eliminate. Figure 3 shows the meaning of symbols contained in the pictograms. The operator must memorise the meaning of the symbols.

The labels should always be kept clean and replaced immediately if they are fully or partially detached or damaged.

ATTENZIONE - Avviare lentamente per evitare dannose sollecitazioni agli organi di trasmissione.
ATTENTION - Démarrer lentement pour éviter des sollicitations dangereuses aux organes de transmission.
ATTENTION - Start slowly to prevent dangerous shock loads to transmission components.
ACHTUNG - Langsam anlaufen lassen, um Überlastung der Antriebsorgane zu vermeiden.
CUIDADO - Arrancar lentamente para evitar esfuerzos peligrosos a los organos de transmission

5470159

Plates with indications and particular warnings for maintenance and a correct use of some parts of the machine. The respect of these plates lengthens the duration and the efficiency of the Mulcher.

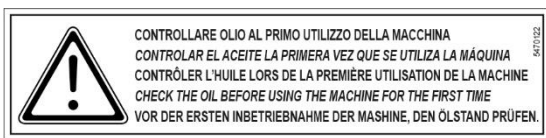

5470152

Check the oil level the first time the machine is used.

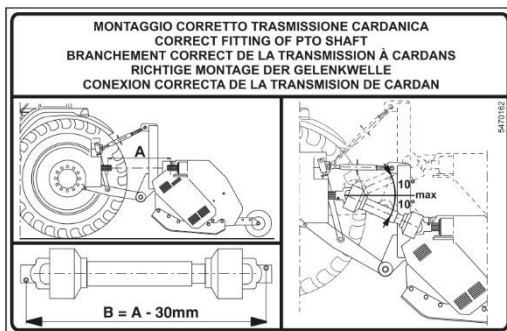

5470152

Indicates the correct functioning of the input PTO shaft.

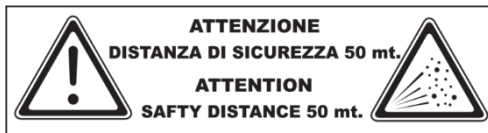

Keep clear from the moving machine;
 Keep at a safe distance.
 Keep away from moving parts.



CPMAN00388

Lifting point

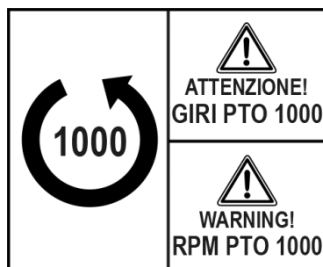

PTO maximum operating speed.

Do not exceed the stated maximum operation speed as stated on the decal near the gearbox of the machine.



Read the use and maintenance manual with care prior to starting up the machine.



Risk of cutting off feet.
Keep at a safe distance.
Do not remove protections before halting and disconnecting the machine.



Always disconnect the machine from the tractor prior to any maintenance and/or lubrication work.



Risk of cutting off hands.
Keep at a safe distance.
Do not remove protections before halting and disconnecting the machine.



Risk of falling.
It is prohibited to climb onto the machine.



Risk of entanglement in the PTO shaft.
Keep away from moving parts.



Risk of ejected objects.
Stay at a safe distance.



Risk of crushing.
Do not stand between the machine and the tractor.



Risk of entanglement on belts.
Do not approach moving parts.



Greasing point.

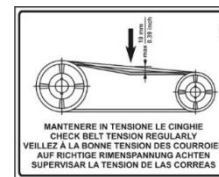

Indicates maximum adjustment movement (1cm = 5 Kg) of the belt, for correct transmission.



Use the protection mask

Use protection gloves

Use protection muffs

Use the protective overalls

Use protective footwear



Operating, servicing and maintaining this equipment can expose you to chemicals which are known to the State of California to cause cancer and birth defects or other reproductive harm.

Figure 3

Figure 4 shows an indication of the precise points on the machine where labels are usually applied by the manufacturer.

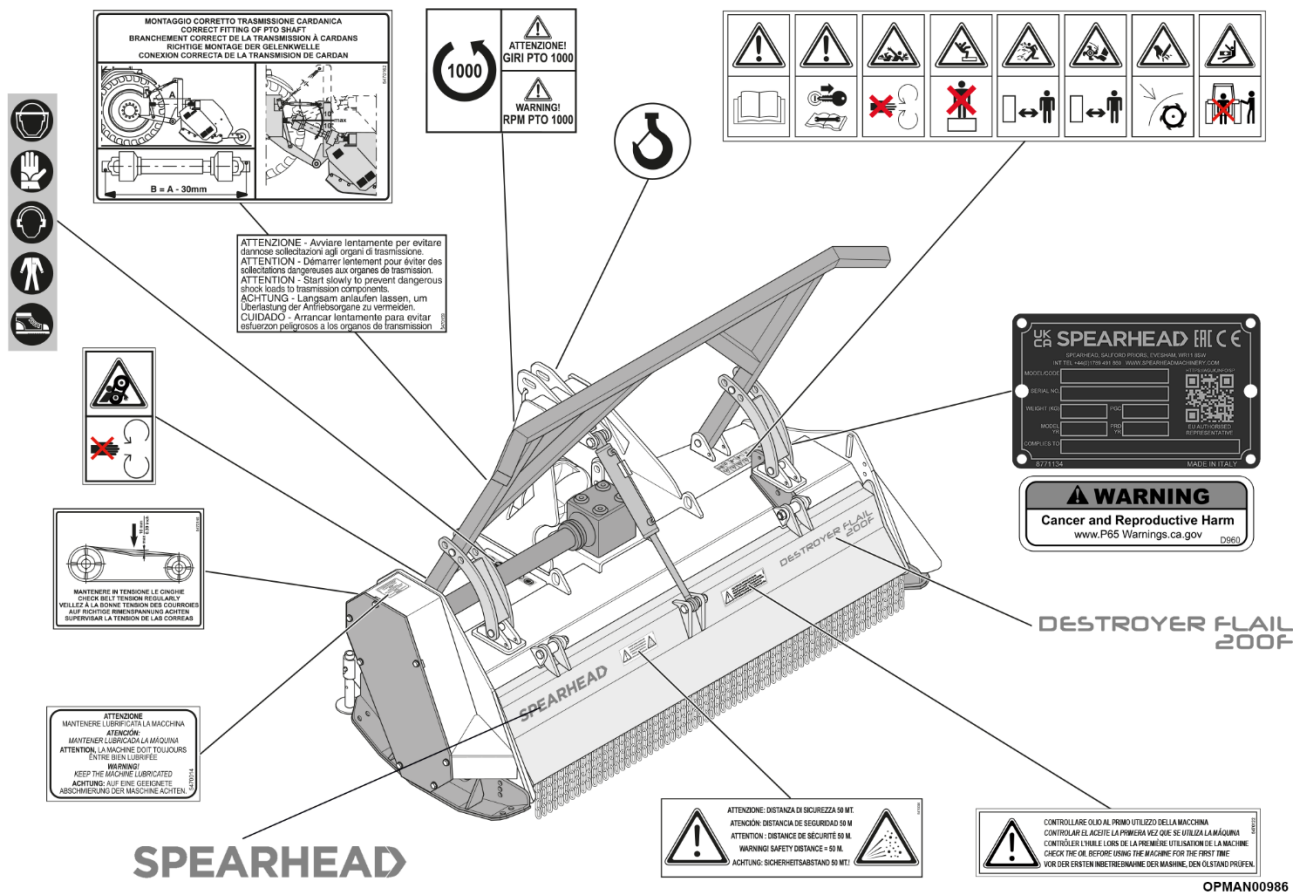

Figure 4

2.3.1 Proposition 65



Operating, servicing and maintaining this equipment can expose you to chemicals including gasoline, diesel fuel, lubricants, petroleum products, engine exhaust, carbon monoxide, and phthalates, which are known to the State of California to cause cancer and birth defects or other reproductive harm.

To minimize exposure, avoid breathing exhaust, do not idle the engine except as necessary, service your vehicle in a well-ventilated area and wear gloves and wash your hands frequently when servicing your vehicle. Battery posts, terminals and related accessories contain lead and lead compounds, chemicals known to the state of California to cause cancer, birth defects or other reproductive harm.

For more information go to www.P65Warnings.ca.gov.

This website, operated by California's Office of Environmental Health Hazard Assessment, provides information about these chemicals and how individuals may be exposed to them.

2.4 Clothing

In general, it is necessary to wear suitable clothing for the work to be carried out. In particular, as far as Mulcher use, obey the following provisions:

- **It is mandatory** to use clothing, which is as suitable as possible, meaning not too loose and without any protruding or moving parts (for example ties or necklaces). Do not wear belts, rings and chains. Always use sturdy safety footwear. Long hair must be tied using a specific cap.
- **It is mandatory** to use protective goggles or a mask before proceeding with the work in order to protect the face and eyes from vegetable fragments which may be projected outwards during mowing.
- **It is mandatory** to use protective muffs in order to safeguard hearing from noise from the equipment during work

2.5 Ecology And Pollution

Below are the minimum provisions to be followed in order to reduce the risk of environmental impact connected to the use of the machine:

- If the Country where the machine is used foresees specific sound emission limits, it is best to adapt to the provisions in these standards, if necessary, being supplied with suitable protective equipment (earplugs, muffs, etc.).
- **It is mandatory** to respect current legislation of the Country where the Mulcher is used, related to use and disposal of lubricants and products used for machine cleaning and maintenance, observing the recommendations of the manufacturer of those products.
- If replacing worn parts or during demolition, one must follow anti-pollution laws foreseen in the country where the Mulcher is used.
- **It is prohibited** to pour products used for cleaning or polluting substances into the sewerage drain, on the ground, in watercourses, or into the environment.
- **It is mandatory** to collect products used for cleaning and polluting substances in appropriate containers, store them and deliver them to companies authorised for their disposal.

2.5.1 Disposal

If deciding not to use the Mulcher, it is best to take a few precautions in order to avoid the risk of environmental pollution. The various parts of the machine must be treated as if they were special waste. One must proceed by taking apart the equipment, grouping the various parts and components in similar parts (rubber, metal, plastic, etc.), providing for disposal of these parts separately, according to existing anti-pollution laws of the Country where the machine was used. Please note that, in general, **exhausted lubricating oil, rubber parts and scrap metals are special waste.**

2.5.2 Storage

If the machine is to be set aside for a long period, it is recommended to:

- Treat the Mulcher according to the instructions contained in the "5.2. Cleaning the Mulcher" paragraph;
- Check the machine and have any damaged parts replaced;
- Fully tighten all screws and bolts, in particular those which secure the teeth;
- Perform a general thorough lubrication;
- Place the Mulcher in a dry area where it cannot be touched by persons not authorised to use it and rest it on struts of wood.
- Protect the entire machine with a tarpaulin.

If these operations are carried out properly, the user will find the Mulcher in perfect condition when it is required again.

If the Mulcher is to be dismantled, comply with the relative anti-pollution legislation of the Country of use.

It should not be forgotten that the Manufacturer is always available if you require any assistance or spare parts.

2.6 Safe Use

- **It is prohibited** to use the Mulcher in ways that are different from the indications contained in the paragraph "1.6. Intended use".
- **It is prohibited** to use or have the Mulcher used by anyone who has not read and completely understood the information contained in this manual.
- **It is prohibited** to use or have the Mulcher used by personnel that are not competent or properly trained or not in good health or physical condition.
- **It is forbidden** to drive the agricultural tractor attached to the Mulcher or have it driven by personnel without an appropriate driving licence.
- **It is forbidden** to approach or stop near the Mulcher when the machine is running.
- **It is forbidden** to stop between the agricultural tractor and the Mulcher (area taken up by the input PTO shaft) if the combustion engine is running.
- **It is forbidden** to abandon the driver's seat on the agricultural tractor with the combustion engine running when the Mulcher is running.
- **It is forbidden** to alter, tamper with or bypass the safety devices provided by the manufacturer.
- **It is forbidden** to operate when the labels indicating the warning signs are missing or damaged. Have them immediately replaced with other labels having the same meaning.
- **It is forbidden** to use the Mulcher when even one split pin, elastic pins or shims supplied with the machine is missing.
- **It is prohibited** to come close and/or touch moving parts during the work.
- **It is prohibited** to tamper with, remove, damage or exclude any part of the machine.
- **It is forbidden** to deposit items on the Mulcher which can harm persons or animals, or damage property should they fall.
- **It is forbidden** to abandon the Mulcher and leave it unattended. The machine and the work area should always be monitored.
- **It is forbidden** to transport persons or items on board the Mulcher while driving with the tractor.
- **It is mandatory** to check that all the safety devices of the Mulcher are intact and functional before using it.
- **It is mandatory** to check that the agricultural tractor on which the Mulcher is installed is of adequate power, weight and configuration, compatible with the model fitted.
- **It is mandatory** to disconnect the input PTO shaft from the PTO and set the control lever of the tractor hydraulic lifter in the blocked position when driving on the road with the Mulcher lifted.
- **It is mandatory** to use the type of input PTO shaft indicated by the manufacturer of the Mulcher.
- **It is mandatory** to set the control lever of the lifter in the blocked position before connecting or disconnecting the Mulcher from the three-point hitch of the tractor.
- **It is mandatory** to comply with highway regulations in force in the country where the Mulcher is used.
- **It is mandatory** to verify that the ground on which the tractor moves is level and sturdy, before using the machine.
- **It is mandatory** for the environment where the machine operates to have adequate lighting. Insufficient or excessive lighting may pose a risk to the operator.
- **It is mandatory** to familiarize yourself with the control devices and their functions prior to starting work;
- **It is mandatory** to make sure that the maximum number of revolutions of the PTO is set to 540/1000 rpm before powering it.
- **It is mandatory** to make sure that the input PTO shaft is connected properly and is fitted with the security devices required before powering the PTO.
- **It is mandatory** to use suitable clothing. Strictly avoid long or loose clothing that could be caught in any way by moving parts. Wear suitable helmets, glasses, gloves, footwear, etc.
- **It is mandatory** to disconnect the input PTO shaft connecting the gearbox of the Mulcher to the tractor PTO before starting any maintenance.
- **It is mandatory** to lower the Mulcher attached to the lifter unit, switch the combustion engine off and remove the ignition key from the dashboard of the tractor before leaving the driver's seat and engaging the parking brake.
- **It is mandatory** for the interventions and adjustments to always be performed with the machine switched off and disconnected from the power.
- **It is mandatory** to stop the machine and inspect it if abnormal vibration is noted or have it inspected by personnel assigned by the manufacturer until the causes are identified and eliminated.
- **It is mandatory** to contact a dealer if the machine stops during operations or a component malfunction.
- **It is mandatory** to always verify, before starting up the Mulcher, that no persons and/or animals are within 50 metres in any direction from the machine.

- **It is mandatory**, if the agricultural tractor has no closed cabin, for the operator to use ear protectors and a dust mask if the working ground lifts a considerable amount of dust. Ensure that the tractor is fitted with a Rollover Protection Structure (ROPS).
- **It is mandatory** to periodically verify that the screws and bolts are tightened and secure, especially those that secure the teeth.
- **It is mandatory** to use the types of lubricating oils indicated by the manufacturer.
- **It is mandatory** to periodically check the integrity and functionality of the safety devices.
- **It is mandatory** to comply with the laws in force in the country of installation on the use and disposal of products used for cleaning and performing maintenance on the machine, considering the recommendations of the manufacturer of the given products.
- **It is mandatory** for the Mulcher to be handled without being subjected to impact with other objects which could compromise the optimal functionality.
- **It is mandatory** for the Mulcher to be lifted adequately and with suitable lifting accessories and harness and according to the regulations in force in the country where these operations take place.
- **It is mandatory** for maintenance on the Mulcher to only be performed by skilled and specialized personnel, in strict compliance with the instructions in this manual, and any worn or damaged parts should be replaced.
- **It is mandatory** to always use original spare parts when carrying out repairs and maintenance.
- **It is mandatory** to set the Mulcher in a safe place which is protected from the elements, when the work is completed.

The Mulcher has been designed and built in accordance with current safety regulations. Special maintenance (repairs) must only be performed by qualified personnel and original spare parts must be used.

2.7 Safe Maintenance

In order to guarantee safe maintenance of the Mulcher it is necessary to respect the following provisions:

- **It is prohibited** to remove or tamper with the safety devices.
- **Periodically check** safety device integrity and operation.
- **Periodically check** screws and bolts tightness.
- **It is mandatory** to periodically verify the condition of the hoses. They must not be cut or have abrasions, otherwise immediately replace them with other hoses having the same characteristics.
- **It is mandatory** to comply with the recommended oils.
- **It is mandatory** to switch the tractor engine off and always disconnect the input PTO shaft before cleaning or performing maintenance on the Mulcher.
- **It is mandatory** to strictly perform maintenance on the Mulcher according to the instructions in this manual and replace the damaged or worn parts with original spare parts only.
- **It is mandatory** for maintenance on the Mulcher to only be performed by skilled and specialized personnel, in strict compliance with the instructions in this manual.
- **It is mandatory** to always use original spare parts when performing repairs and maintenance on the Mulcher. Using non-original parts immediately renders the warranty null and void and can compromise the durability and reliability of the machine.
- **It is mandatory** for parts or components of the Mulcher to be lifted adequately and with suitable lifting accessories and harness and according to the regulations in force in the country where these operations take place.
- **It is forbidden** to perform welding, flame-cutting or with a tool or holes on the structure of the Mulcher.
- **The dangers** signalled on the machine by way of pictograms (labels) of suitable dimensions, applied on the Mulcher in easy to see places.
- These signals give the proper indications in an essential manner in order to avoid danger and prevent the risk of damage or injury. These signs must always be kept clean and immediately replaced when removed, even partially, or damaged: **it is prohibited** to operate the Mulcher when even one of these signs is missing from the spot where it was installed by the Manufacturer.
- **It is mandatory** to save and keep this manual for the entire life of the Mulcher.

3 Installing The Mulcher

Before starting to use the Mulcher, **it is mandatory** to read and perfectly understand the instructions contained below.



WARNING! Read the instructions contained in the chapter, "2. General Safety And Accident Prevention Standards".

3.1 Delivery

The Mulcher is supplied fully assembled and protected with a "heat-shrink" plastic cover. Handles protrude from the cover for lifting and vertical handling of the Mulcher with straps or cables able to withstand the machine's weight, as illustrated in Figure 5.

To transport by carriage, make sure that the Mulcher is securely anchored to the floor with suitable standard ropes or straps, in accordance with the requirements set out in the "4.4. After Use" paragraph.

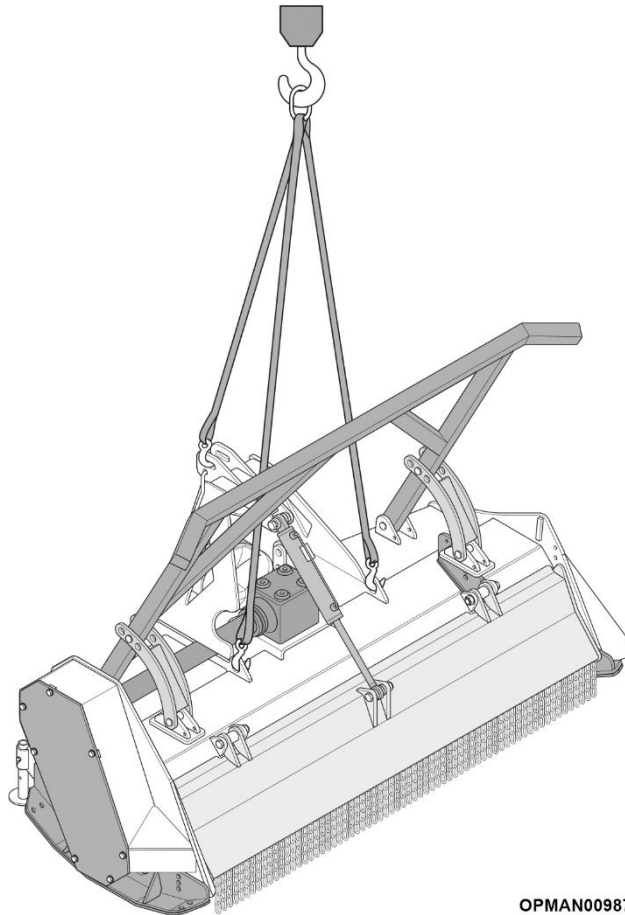

OPMAN00987

Figure 5



WARNING! The machine must be lifted with maximum care and by using lifting devices suitable for the weight and size of the same.



WARNING! Due to the danger of this operation, it must be performed by expert and responsible personnel. For the lifting device to be used **it is mandatory** to comply with the safety regulations prescribed by the laws in force in the country where the machine is used. Do not touch the Mulcher and do not stop within the operating range of the crane.

After transportation, remove the protection film and check that the machine was not damaged in any way. Spearhead cannot be held responsible for any damage caused by handling carried out any differently from that described in the manual.

3.2 First Use



DANGER! Connecting the Mulcher to the agricultural tractor is a very dangerous phase. Ensure you carry out the entire operation in strict compliance with the instructions.

The Mulcher features a gearbox with a 1" 3/8 spline power take-off that can be adapted to any agricultural tractor PTO with an input PTO shaft.

Upon the first installation, simply remove the machine from the packaging and set it up correctly.

The installation, adjustment and testing of the Mulcher involve hazardous operations. Carefully read all the instructions described in this manual. If in doubt, contact the Manufacturer directly.

In any case, before commissioning the Mulcher, immediately after transport, check that the supply is intact and complete. The Mulcher can be installed and subsequently removed from the agricultural tractor according to the requirements of the user.



DANGER! Spearhead cannot be held liable for damage to persons, animals or property, caused by noncompliance with the safety and accident prevention regulations or operations which do not conform to the information provided in the user and installation instructions.

3.2.1 Prior To Installation

Before installing the Mulcher, it is advisable to check the suitability, good condition and adjustment of the agricultural tractor on which it will be installed:

- Begin by first checking the power in kW or hp and the minimum mass required of the agricultural tractor. They must match the minimum characteristics stipulated by the Manufacturer of the Mulcher, which are indicated in this manual in the "1.4. Technical Data" paragraph;
- Move the tractor to the place where the Mulcher was deposited after being transported and stop it in a safe and practical position for assembly to be performed on level ground;
- Lift the Mulcher with a lifting device of adequate capacity and move the machine near the rear part of the tractor, in line with the three-point hitch support. Move the tractor in reverse to attach the equipment to it;



WARNING! Due to the danger of this operation, it must be performed by expert and responsible personnel. Do not touch the Mulcher and do not stop within the operating range of the lifting device.

3.2.2 Application To The Tractor



WARNING! Clean and clear the installation area from any obstruction before starting to work. The area must be specifically closed off and personnel not assigned to the works must be made to move away. The available means must be verified to be intact and suitable. The operator must also tighten all the bolts and fittings properly, using suitable tools.



DANGER! All the following assembly and installation operations must be carried out with the tractor engine switched off.

The application of the Mulcher to the tractor must take place on flat ground. All the Mulchers are applicable to any tractor equipped with a universal three-point hitch.

The Manufacturer declines all responsibility for the breakage of the tractor.

Proceed as follows for the coupling (see Figure 6):

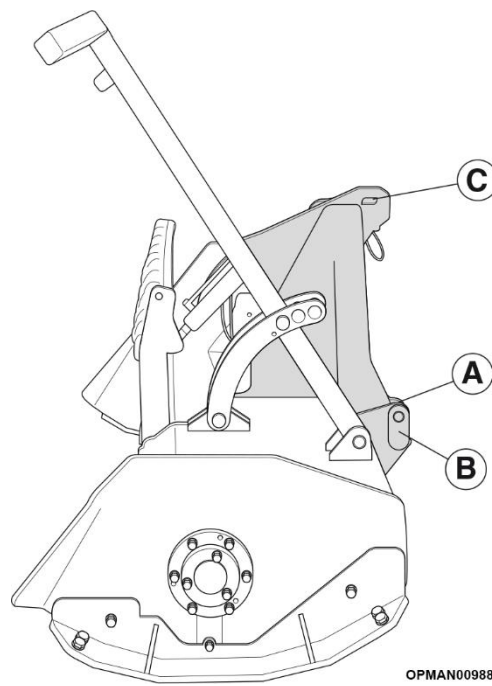

Figure 6

- 3.2.2.1 Use appropriate protective gloves to move the tractor until the tractor lower link arms are inside the plates (A) and (B). Insert the pin into the pre-set hole and secure it with the split pins.
- 3.2.2.2 Switch the tractor off and engage the parking brake.
- 3.2.2.3 Lock the lower link arms on the tractor with the appropriate chains and parallel tighteners: this precaution must take place to avoid any sideways movement of the Mulcher.
- 3.2.2.4 Engage the Input PTO shaft and make sure that it is perfectly locked on the power take-off.
- 3.2.2.5 Verify that the protection rotates freely and secure it with the appropriate chain. Remove the support from the Input PTO shaft.
- 3.2.2.6 Connect the top link (C), securing it with the appropriate pins and split pins.
- 3.2.2.7 Use the adjustable top link to correctly adjust the pitch angle of the front of the machine, making sure that the skid of the Mulcher is parallel to the ground. This is very important to obtain parallelism between the Mulcher power take-off and the tractor power take-off.

Operating in these conditions means limiting the stresses on the power take-off and life of the Input PTO shaft and the Mulcher itself.

The correct position of the tractor/Mulcher unit is such when the Mulcher is at a distance from the tractor so that the input PTO shaft does not extend beyond 5-10 cm from the maximum closing position.

- 3.2.2.8 Engage the PTO and accelerate up to a minimum of 400 rpm. Then test lift the Mulcher to verify proper operation.

3.2.3 Input PTO Shaft

It is mandatory to only use the input PTO shaft supplied as standard by Spearhead; see Figure 7. The Company assumes no liability if an input PTO other than the one supplied is used.



DANGER! An input PTO shaft applied to a tractor is a mechanical part, which, when operating, can be extremely dangerous for those using it. Therefore, you must be extremely careful regarding operations that involve these mechanical parts.



CAUTION! Before starting the power take-off, ensure that the rotation speed is the same as that required for the Mulcher (540 / 1000 rpm).



WARNING! Spearhead declines any and all liability for damages caused by the Mulcher to persons, animals or property, resulting from use other than that described in this manual, or due to damage caused by negligence or by not observing the instructions contained in this manual.



CAUTION! It is forbidden to operate with the input PTO shaft worn or damaged. Before starting to work, replace the input PTO shaft.

For any spare parts only contact the Authorised Centres.

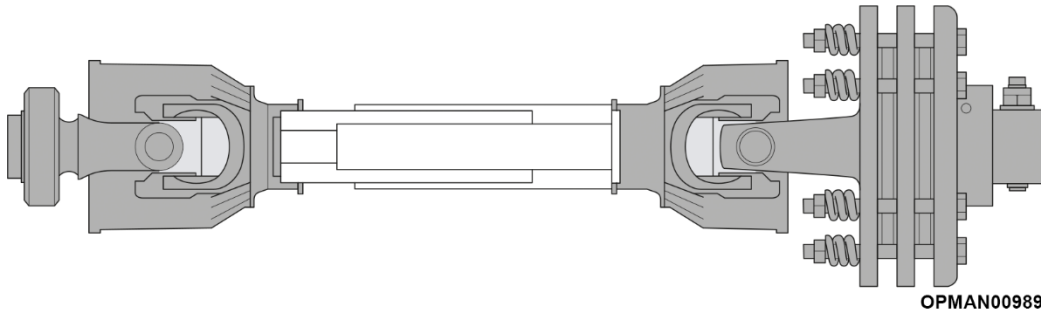

Figure 7

The mulcher is fitted with a free-wheel in the gearbox and can be applied to a tractor with no double clutch, without the danger that the inertia of the rotor preventing the stopping of the mulcher/tractor assembly.



CAUTION! The manufacturer of the cardan shaft recommends that no changes be made to it. The Cardan shaft rotates at a significant speed and is subjected to balancing before being placed on the market. Therefore, any changes could cause imbalance, which affect the integrity of the cardan shaft. When the cardan shaft is at its maximum length in any work conditions, the telescopic pipes should overlap by at least 1/3 of their length, as illustrated in (Figure 8). When operating at full power, the minimum play should be 4 cm. Before start-up, check that the safety chains are on the protection devices to prevent them from rotating together with the cardan shaft; also check that the protection devices are in perfect condition. Lastly, check that the cardan shaft is suitable for transmitting the power required for the Mulcher. When in doubt, contact the Manufacturer.

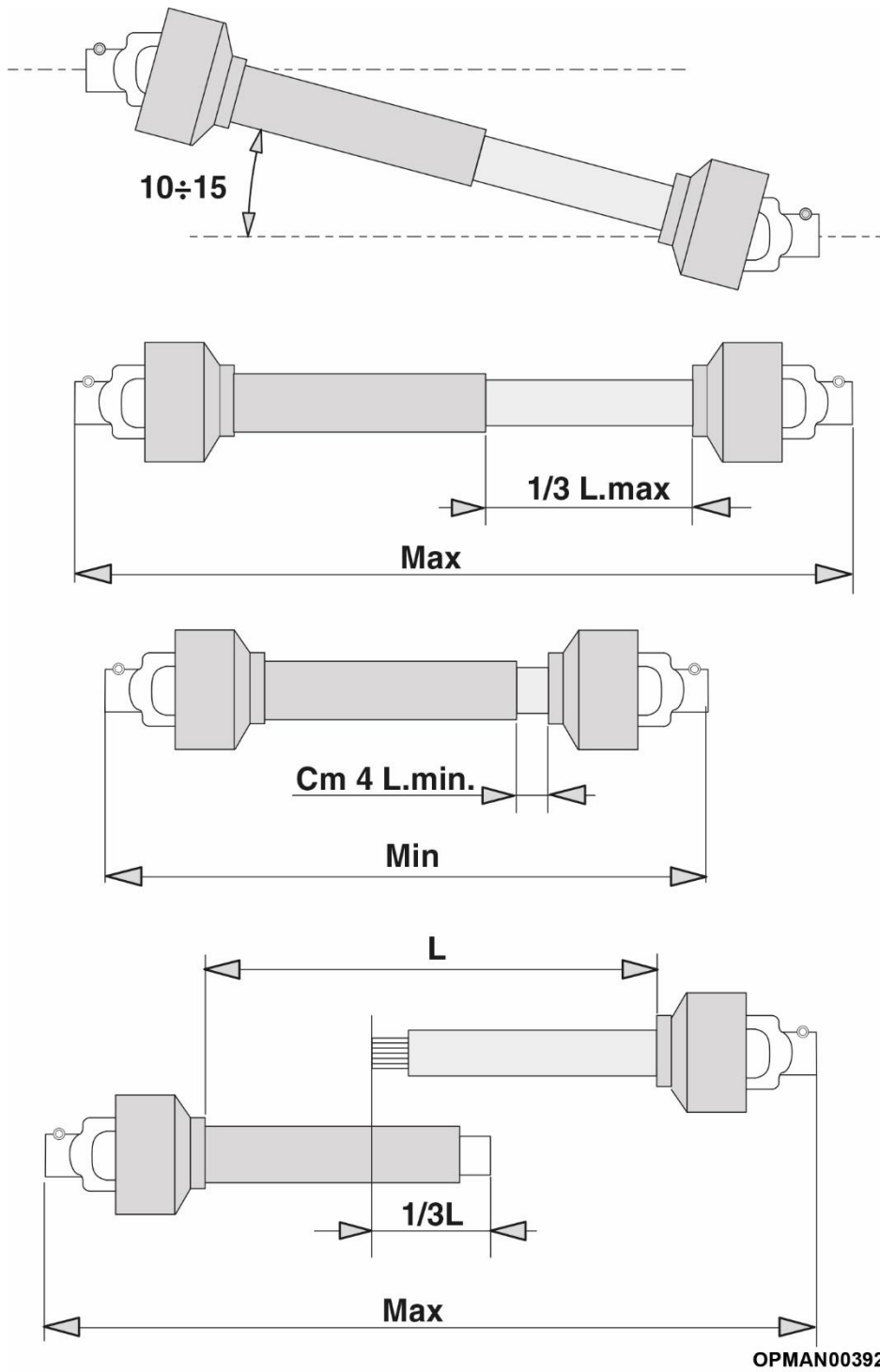

Figure 8

(This page is left blank intentionally)

4 Usage Instructions

4.1 Before Use

Prior to starting up the Mulcher, carry out the following operations;

- Check that all the screws and nuts are fastened, especially those that secure the teeth;
- Verify that the hydraulic hoses are in good working order;
- Check that the input PTO shaft is inserted correctly between the gearbox and the tractor PTO and also check the operation of the hydraulic services.



WARNING! Before operating the Mulcher, check the efficiency of the power systems and familiarize yourself with the controls.

During transport and every time, the Mulcher must be lifted with the tractor it is fastened to, the lifting device should be adjusted so that the machine is lifted from the ground by about 35 cm (see Figure 9).

Furthermore, verify that all blocking devices are activated so that the Mulcher is absolutely safe.

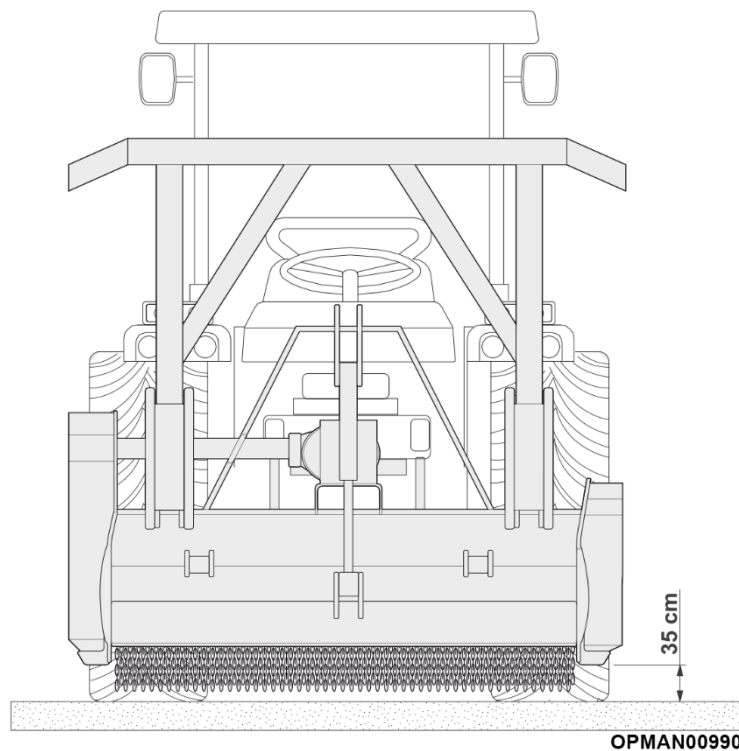

Figure 9

4.2 Machine Settings

A number of adjustments can be made on the Mulcher to help the operator in the various working conditions that may arise.



DANGER! All adjustments must be made with the machine switched off, the parking brake engaged and the PTO disabled.

4.2.1 Adjustment Of The Skids And Roller

Adjust the position of the skids so that the teeth do not come out of the plane made by the two skids. In this way, even if there are irregularities in the ground, the teeth will not penetrate the ground itself. It is important to check that the Mulcher is perfectly parallel to the ground in order to obtain perfect operation.

- 4.2.1.1 Place the machine on a level surface with two spacers of approx. 12 cm set inside the machine at the rotor ends. Brake the tractor, switch it off and remove the keys from the dashboard.
- 4.2.1.2 Remove the bolts (D), see Figure 10.
- 4.2.1.3 Adjust the position on the skid (E) taking care to move it by the same amount, both in front and at the back.
- 4.2.1.4 Reassemble bolts (D) and tighten them.
- 4.2.1.5 Perform the same operation for the opposite skid.
- 4.2.1.6 Start up the tractor and move the machine.

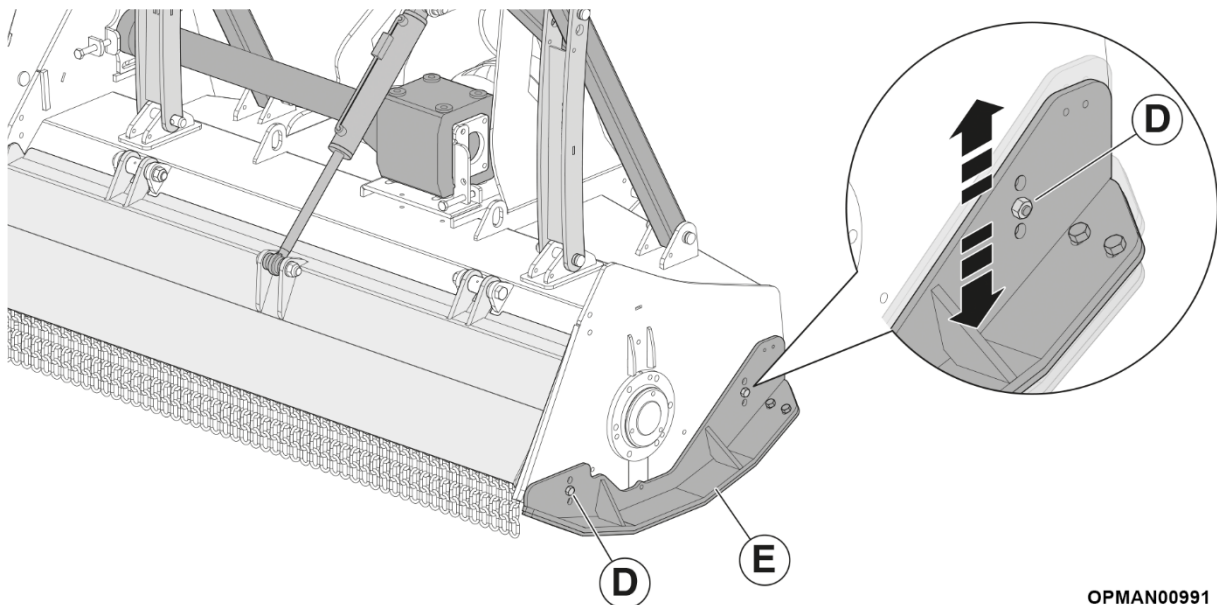

Figure 10

OPMAN00991

4.2.2 Adjustment Of Working Height

Adjust the position of the skids so that the teeth do not come out of the plane made by the two skids. In this way, even if there are irregularities in the ground, the teeth will not penetrate the ground itself. It is important to check that the Mulcher is perfectly parallel to the ground in order to obtain perfect operation.

The adjustment must be carried out using the adjustable top link between the tractor and machine; Figure 11.

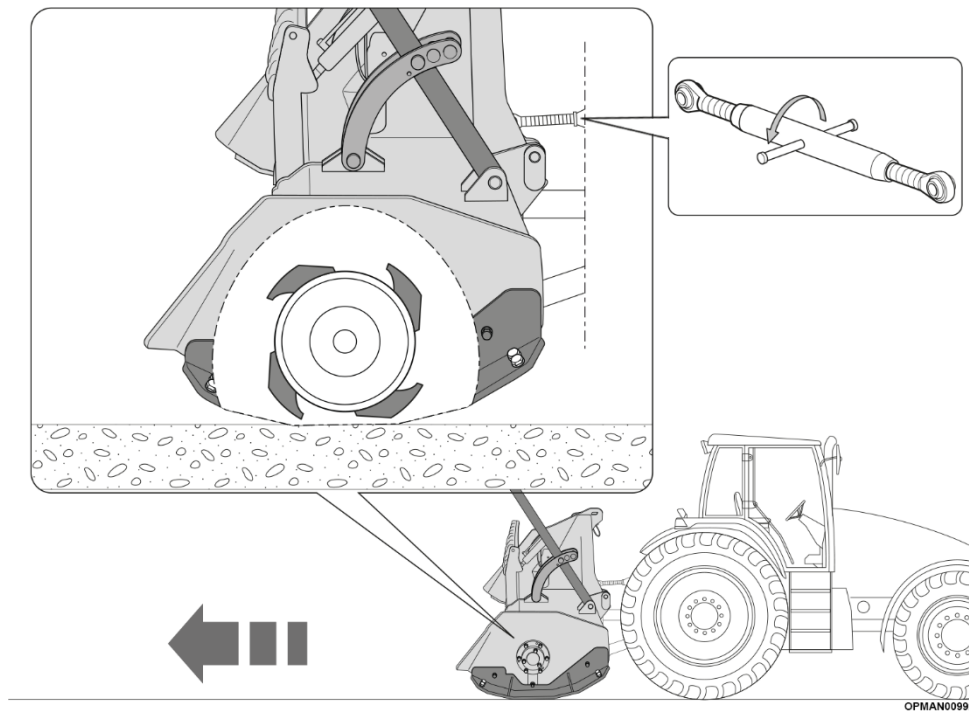

Figure 11

4.3 Using The Mulcher

After having familiarized yourself well with the controls, worn the PPE (personal protective equipment) required, set the machine in the desired working position, and having connected the gearbox and secured it properly to the tractor PTO by means of the input PTO shaft and hydraulic hoses to the tractor's hydraulic services, start the tractor engine, disengage the parking brake, and engage the PTO while maintaining the engine at low rpm.

Before starting work, make sure that there are no exposed persons and/or animals near the machine. Otherwise, have them move away.

On start-up, move slowly with the tractor, gradually and slowly lower the Mulcher until it reaches the ground. Then, the engine can be brought to the work speed.

It is recommended not to press the accelerator pedal rapidly when the tractor is stationary, and the PTO is engaged, and the Mulcher is not running. This can cause damage to the machine and the tractor.

The processed material is shredded correctly by maintaining the tractor at a low forward speed and the rotor rotating at a constant speed.

N.B: Spearhead recommends that you always use a tractor equipped with a closed cab.



WARNING! The speed of the tractor with the Mulcher working must never exceed 5km/h in order to avoid breakage or damage.



DANGER! During work, stones or other objects found in the terrain can be lifted and projected by the rotating teeth. Constantly check that there are no persons or animals within the operating range of the Mulcher (Figure 12).



WARNING! Spearhead declines any and all liability for damages caused by the Mulcher to persons, animals or property, resulting from use other than that described in this manual, or due to damage caused by negligence or by not observing the instructions contained in this manual.



WARNING! Avoid letting the Mulcher rotate idly. During work, avoid making turns with the Mulcher lowered and do not work in reverse. **It is mandatory** to always lift the Mulcher when changing direction or reversing the machine and tractor.

During transportation and any time when it becomes necessary to lift the Mulcher, it is necessary to adjust the tractor linkage so that the Mulcher itself is lifted more than about 30-35cm from the ground.

Avoid driving on public roads when the Mulcher is dirty with earth, grass or at any time when it produces dirt or obstructs the traffic on the roads.

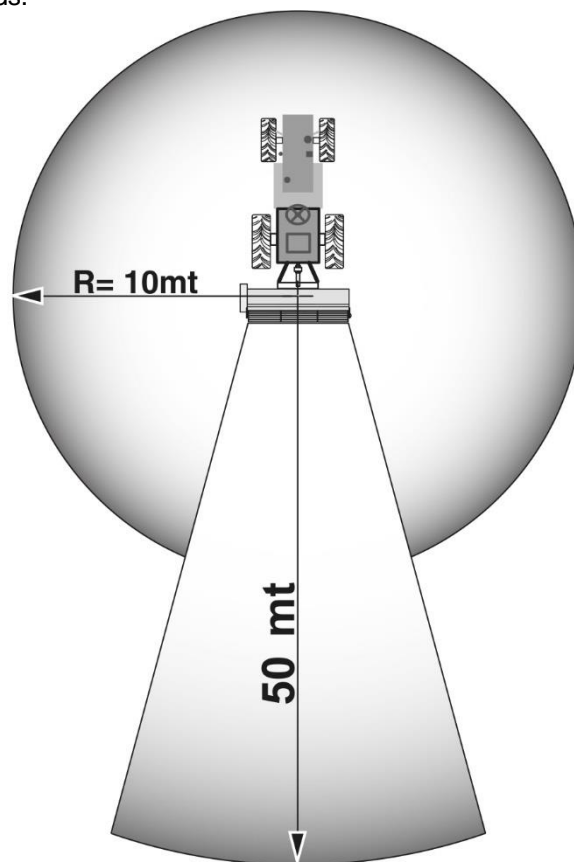

OPMAN00397

Figure 12



WARNING! Pay utmost attention to the shape and arrangement of the logs to avoid cutting trees that might hit the operator when they fall.

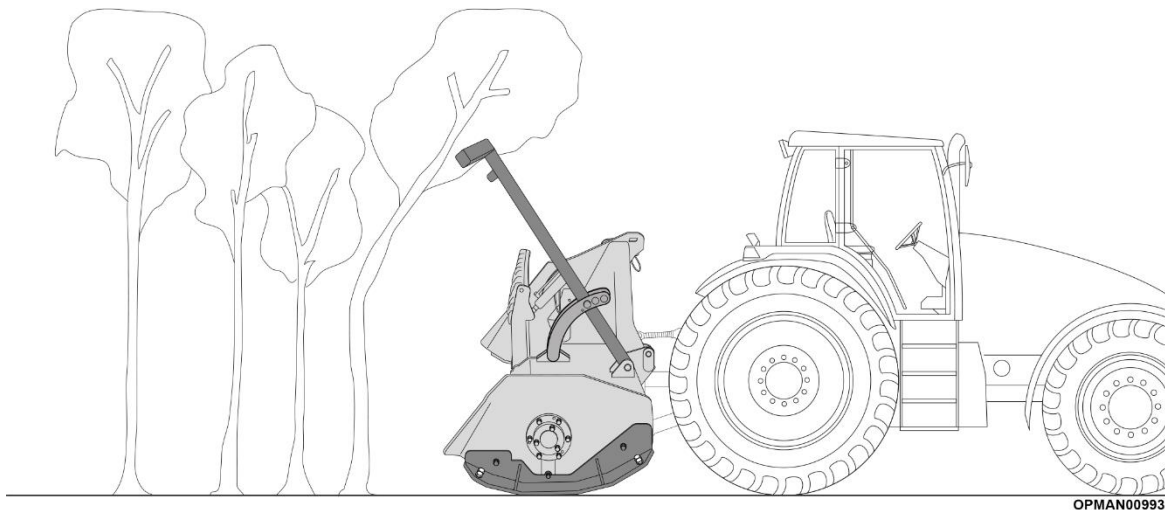

Figure 13

4.4 After Use

A few guidelines must be complied with when the work is complete, in order to make sure the Mulcher is stable when released from the tractor:

- Move to the storage area of the Mulcher, making sure that the supporting surface is flat and free from obstructing material.
- Place the Mulcher on the ground by lowering the linkages of the tractor lifter.
- Raise the rear roller so that the Mulcher rests on the skids acting on the three-point hitch.
- Switch the tractor off and engage the parking brake.
- Before leaving the driver's seat of the tractor remove the ignition key from the dashboard.
- Disconnect the input PTO shaft that connects the gearbox with the tractor PTO.
- Release the top link from the three-point hitch by releasing the appropriate pins and split pins.
- Release the chains and tensioners of the tractor lower linkages.
- Release the pins from the lower linkages by releasing the relevant split pins.
- Climb into the driver's seat of the tractor, start up and move the tractor away from the Mulcher.
- Use the specific supporting feet in the parking position (Figure 14).

Store the equipment, preferably in a covered area, on a suitable and flat surface. Follow the instructions in the "2.5.2. Storage" paragraph of this manual.

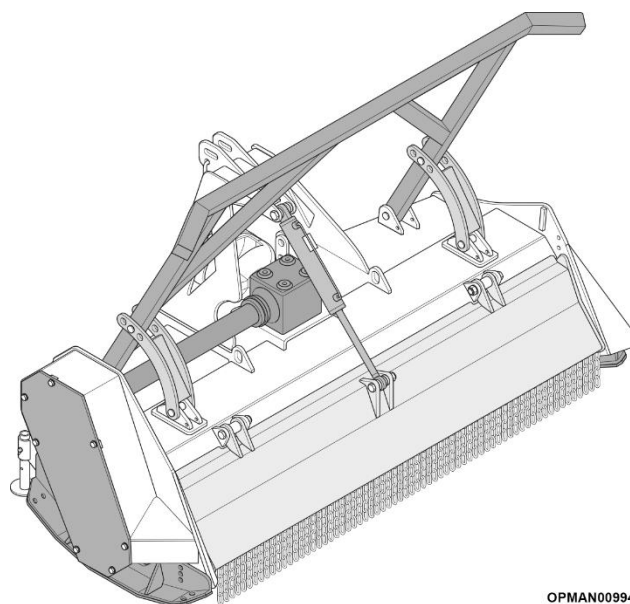

Figure 14

4.5 Safety Devices

There are safety devices in the Mulcher to safeguard the operator.



WARNING! The safety devices must not be tampered or excluded. They should always be kept in perfect working order.

The following are installed:

- **Fixed input PTO protection** covers both crosses and prevents hands from being introduced into the rotating area of the input PTO shaft.
- **Fixed belt protection** covers both belts and prevents hands from being introduced into the transmission area.
- A **safety protection** consisting of a number of sheet metal flaps placed in the lower part of the machine prevents the soil and/or fragments of plants from being projected outwards.
- The **warning pictograms of the residual risk** essentially indicate an existing danger, a prohibition or requirements that are to be met for the operator's safety and for the Mulcher to operate correctly and remain intact.

4.6 Machine Transport Procedure



WARNING! Proceed at a moderate speed, as the mass of the tractor with flail Mulcher lifted changes the stability of the tractor-machine unit, influencing the steering and braking capacity.

It is important to remember that the front axle should have sufficient weight with a load equal to at least 20% of the weight of the agricultural tractor. Check the overall weight and stability of the tractor using the formula indicated below and apply the appropriate weights if necessary.

Influence of the weight of the flail Mulcher	less than or equal	Influence of the weight of the tractor
$M \times (S + E)$	\leq	$0.2 \times T \times i \times Z \times (D + I)$

where:

- i** tractor wheelbase
- D** distance of the front axle from the front ballast
- S** distance between the centre of the rear axle and the centre of the lower link arms of the tractor
- E** distance of the centre of the lower link arms of the tractor from the centre of gravity of the flail Mulcher (750mm)
- T** weight of the tractor + 75kg (operator)
- Z** weight of the ballast
- M** weight of the flail Mulcher, see "1.4. Technical Data" paragraph

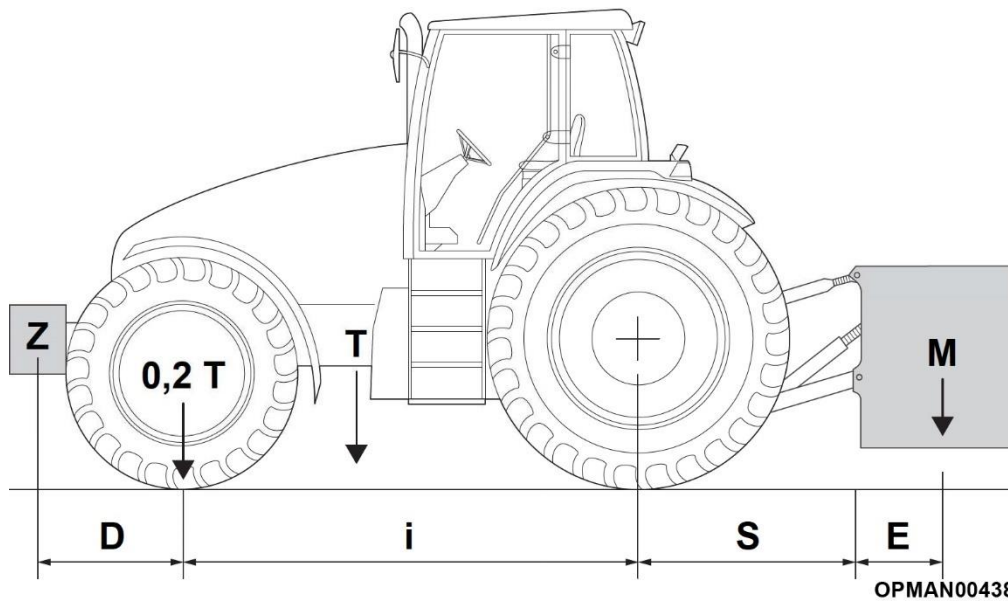

Figure 15

If the machine is combined with an agricultural tractor registered and approved before 6th May 1997, it is also necessary check the compliance with the following relation:

$$M < 0.3 \times T$$

(This page is left blank intentionally)

5 Maintenance

Routine maintenance operations are listed below. More extensive maintenance operations (re-pairs of parts or components) can be carried out by specialised personnel authorised by the manufacturer.



WARNING! The schedule is for information purposes only and depends on normal operation conditions. Conditions can in fact change depending on the service, the environment and on frequency of use. If conditions are particularly awkward, the frequency of maintenance operations should be amended accordingly.



WARNING! It is mandatory to make sure that the input PTO shaft connecting the gearbox of the Mulcher is disconnected from the agricultural tractor PTO before starting any maintenance.



WARNING! After maintenance, always restore any safety devices that may have been removed, so that they are in place before new work is started.

It is recommended to always use oil of the same type and quality as used previously when refilling or changing the oil. Greasing points should be cleaned carefully before lubrication, to prevent mud, dust or foreign bodies from mixing with the lubricant.

- **It is mandatory** that any repair and/or maintenance intervention be carried out by an operator with suitable physical and intellectual requirements.
- **It is mandatory** to verify that during maintenance or repair operations; unauthorised personnel are kept away from the Mulcher.
- **It is prohibited** to deactivate protection and safety devices. When it becomes necessary to deactivate these devices in order to carry out more extensive maintenance, the operation must only be completed for more extensive maintenance and only by a maintenance mechanic, who will guarantee operator safety and avoid any damage to the machine, as well as restoring the effectiveness of the same devices at the end of maintenance operations.
- **It is mandatory** to switch the engine of the agricultural tractor which the Mulcher is connected to off before performing any maintenance or mechanical setting and disconnect the input PTO shaft.
- **It is recommended** to perform all maintenance that is not covered in this manual in an authorised service centre.
- Before restarting the Mulcher after lubrication and/or maintenance, **it is mandatory** to wait for the authorization of the mechanical maintenance technician who must verify that:
 - the works have been completed;
 - the Mulcher works perfectly;
 - the safety devices are in their correct place and fully functional;
 - no other operations are being performed on the Mulcher.

5.1 Periodic Maintenance

In order to guarantee proper operation of the Mulcher and improved operator safety, it is necessary to periodically intervene with controls and maintenance operations listed in the table shown below.

	Upon The First Use	The First 8 Works Hours	Every 8 Work Hours	Every 50 Work Hours	Every 400 Work Hours
General check	X	X			
Tightening of screws and bolts	X	X	X		
Checking for wear and tear on teeth and their locking screws	X		X	X	
Greasing yokes and Input PTO shaft	X	X		X	
Greasing pivot points	X		X		
Verify gearbox oil level	X			X	
Complete change of gearbox oil	X				X
Check transmission belt tension	X		X		
Tightening taper locks and pulleys (with torque wrench) (44Nm)	X		X		

Table 3



WARNING! The machine must be checked by an authorised concessionary if any of its parts are worn or in poor condition.



WARNING! Replace the hydraulic hoses each time they are damaged or, in any case, before the sixth year. The used hydraulic oil must be properly collected and must not be dispersed into the environment since, according to the laws in force, it is classified as dangerous waste and for this reason it must be given to the proper collecting centres. Please, refer directly to the closest company for the collection of the used oils.

5.1.1 Maintenance On The Teeth



WARNING! Spearhead is not liable for damage caused by vibrations generated by rotor shafts which have not been balanced after the teeth have been replaced. Any requests for replacement under warranty or reimbursement for damage caused due to the rotors malfunctioning will not be accepted.

The teeth with which the Mulcher is equipped are suitable for working on grounds of normal condition. **It is mandatory** to check their integrity and the degree of wear every day. Should the tooth break or get damaged during work, **they must be replaced immediately. Replacing a single tooth is generally not recommended.** This can only be done when all other teeth are in excellent condition and in any case, in order not to compromise the proper operation of the rotor, **it is mandatory** to also replace the opposite tooth so as not to cause an imbalance in the rotor. **It is recommended** to always replace all the teeth and not just the damaged ones, in order to guarantee proper operation.

After changing the teeth, **it is mandatory** to subject the rotor to electronic balancing to guarantee the Mulcher works properly, free from vibrations that can cause serious damage to the machine.

To replace worn or broken teeth it is necessary to:

- position the Mulcher and tractor on flat ground;
- raise the Mulcher with the linkages to the maximum height possible;
- place adequate support stands under the Mulcher on both sides for the machine to be perfectly stable;
- stop the tractor and put on the emergency brake;
- be equipped with adequate spanners and proceed with the replacement of the teeth: forcibly tighten the securing bolts;
- before installation, weigh the individual teeth as differences in weight are inevitable;
- select pairs of teeth that have the same weight and mount them on the rotor in opposite diametrical positions.

The quality, integrity of the Mulcher and its safety depend on the care dedicated to the teeth, which must be replaced immediately if damaged. Normal wear is exceeded and enhanced when working on sandy terrain or if

the Mulcher is too low and therefore, impact with obstacles occurs more often and distortion or cracks can be caused to the teeth.

Damage to the teeth will inevitably deteriorate the quality of work and increase vibration, possibly damage the Mulcher and partially or totally damage the teeth resulting in metal fragments being dangerously projected at high speed into the area where the machine operates. When replacing the teeth, **it is mandatory** to check that the seat of the flail bolt is not ovalized and its size is not more than 2 mm more than the original diameter.

For worn teeth and bolts (see Figure 16):

- Tooth wear is directly proportional to the work done.
- Bolts fix the teeth to the rotor shaft using two bolts, see Figure 16. Each time a tooth is replaced, the two bolts also be replaced with new items.

When finished, remove the support stands, start up the tractor, lower the Mulcher and turn off the tractor.



CAUTION! Only use original spare parts.

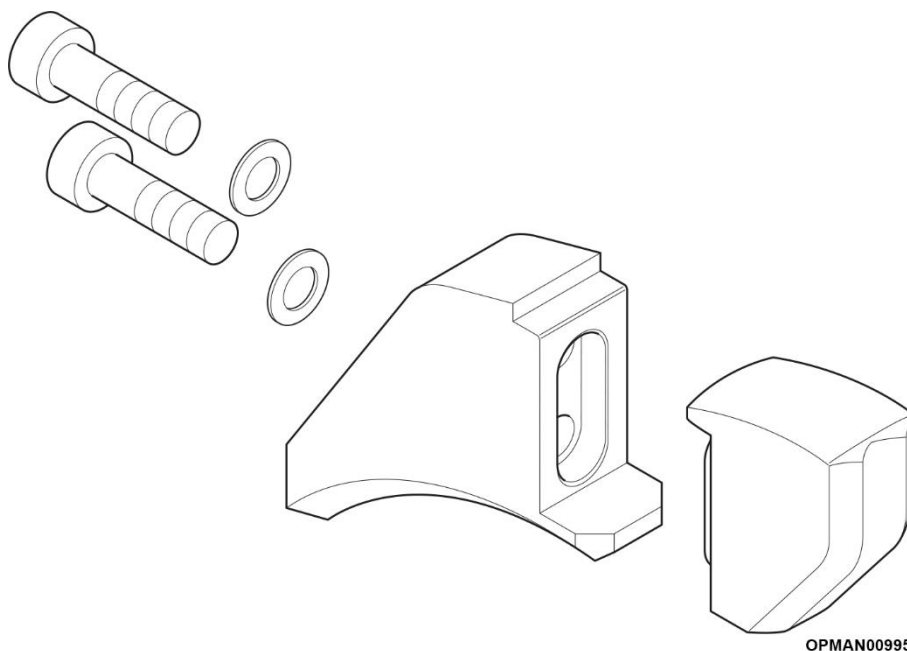

Figure 16

5.1.2 Belt Maintenance

The driving force is transmitted to the rotor shaft of the Mulcher by belts with adjustable tension. Periodically, or if the belts malfunction or slip, check the tension of the transmission belts from the appropriate slit and, if necessary, replace them.

With reference to Figure 17, operations to be carried out are the following:

- Remove the nuts fastening the belt guard (A);
- Remove the guard;
- Loosen the 4 bolts securing the gearbox (B);
- Loosen and adjust the nuts and bolts (C) and (D) to adjust the tension of the belts;

It is advisable to be equipped with a metal ruler of adequate length and, placing it on the edge of the two pulleys, it must touch all four edges of the pulleys themselves.

Press on the belts, in the central area between the two pulleys, with a force of **5kg**: the force must cause a deformation on the individual belt of **1cm**.

At this point:

- Tighten the bolts that secure the gearbox and cross-tube;

- Reassemble the previously removed belt guard.

The belts are stretched when working over time: when replacing a worn or broken belt, for an equal distribution of forces, **it is mandatory** to replace the entire set of belts.

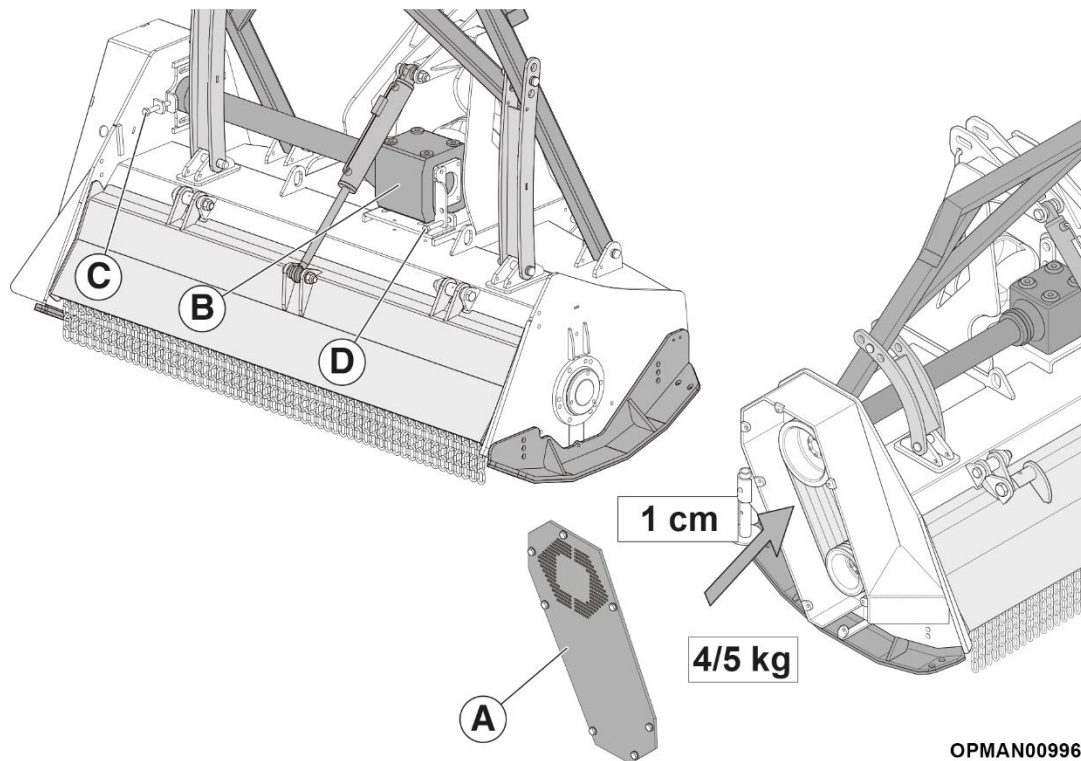

Figure 17

5.2 Clutch Settings

The Destroyer Flail is fitted with a spring clutch which requires initial setup and periodic maintenance and inspection to ensure it is working correctly.

The spring clutch springs need to be measured and set to allow for the correct level of protection to the machine during use. The length setting "d" is shown in Figure 18 with the setting requirement listed in Table 4.

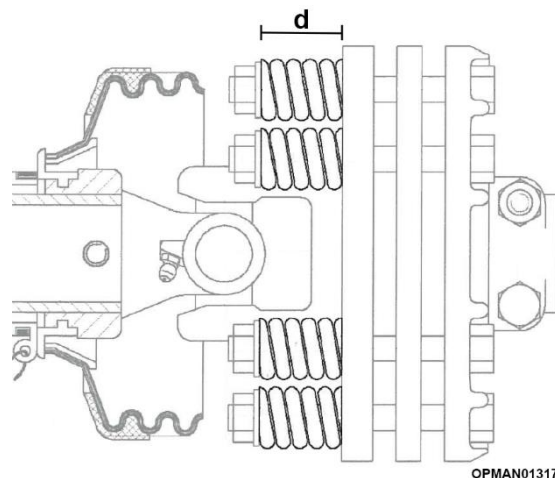

Figure 18

Item	Setting "d"
Input Driveshaft Clutch	43mm (1 1/16")

Table 4

5.3 Cleaning The Mulcher



DANGER! This operation is extremely hazardous so the following instructions must be followed.

- Wear protective gloves and shut off the engine of the agricultural tractor, subsequently disconnecting the input PTO shaft;
- For cleaning at the end of work, before completely stopping the machine, leave it on for 20-30 seconds so that any material residue is ejected;
- The Mulcher must be cleaned using an air jet, water with non-hazardous chemicals and cloths.
- Eliminate any residue of material or dust from the external surface of the machine.

5.4 Lubricants

With reference to Figure 19, following lubricants are to be used for the different parts of the machine:

- For the transmission box (1): SHELL SPIRAX S2 A 80W-90 or equivalent responding the API - GL5/MIL-L-2105C specifications is recommended. The quantity of oil is **1.2 lt.** Do not exceed the prescribed quantity;
- For all (2) and (3) greasing points: SHELL RETINAX WB 2 equivalent is recommended.

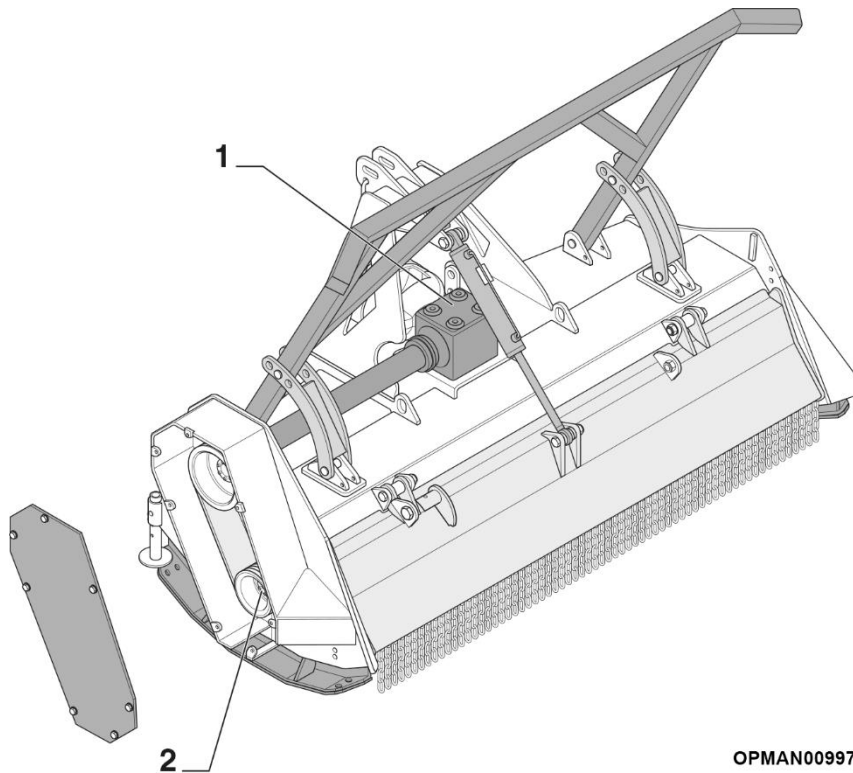

OPMAN00997

Figure 19

(This page is left blank intentionally)

6 Troubleshooting

If the Mulcher malfunctions, search the causes and the solution of the problems in the following table:

Problem	Cause	Remedy
Excessive cutting of the product to be cut	Mulcher too low	Slightly raise the Mulcher from the ground, adjusting the height
	Forward speed too slow	Increase the forward speed
Limited cutting of the material to be cut	Mulcher too high	Slightly lower the Mulcher from the ground, adjusting the height
	Forward speed too high	Reduce the forward speed
	Terrain too wet or muddy	Wait for the terrain to dry
Rotor clogging	Terrain too wet or muddy	Wait for the terrain to dry
	Mulcher too low	Raise the Mulcher from the ground
	Forward speed too high	Reduce the forward speed
Drop in rotor speed	Belt overheating	Adjust belt tension
The Mulcher bounces on the ground or vibrates	Foreign bodies stuck between the teeth	Clean the rotor and teeth
	Teeth mounted incorrectly, without the helical layout or with the edge penetrating the terrain	Check and re-install the teeth
	Worn or broken teeth	Replace the teeth
	Deformation of the rotor due to foreign bodies having hit the central part	Replace the rotor. Contact the Spearhead service centre
Roller support bearing seizure	No oil lubrication	Verify oil level

(This page is left blank intentionally)

7 Spare Parts

7.1 How To Obtain The Correct Spare Part Numbers

For correct part numbers; use the Spearhead interactive online parts books. These are available at <https://my.spearheadmachinery.com/parts/public-interactive-parts-database/>. You will need to enter the machine serial number; see Figure 19.

7.1.1.1 Enter the serial number.

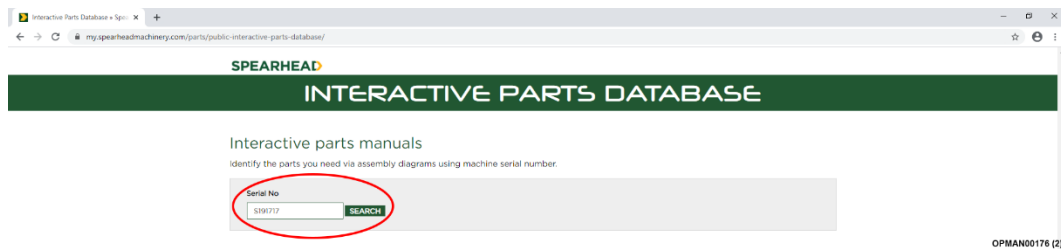

Figure 19 – Type In Serial Number

7.1.1.2 After entering the serial number a specification for the machine will appear. Click on the serial number; see Figure 20.

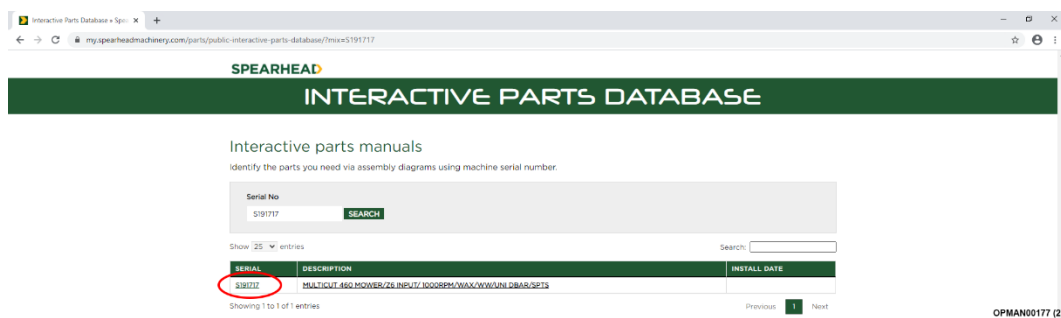

Figure 20 – Click On Serial Number

7.1.1.3 After clicking on the serial number a full parts breakdown, specific to the machine serial number will appear showing the various parts and assemblies of the machine. Click on the specific assembly picture required; see Figure 21.

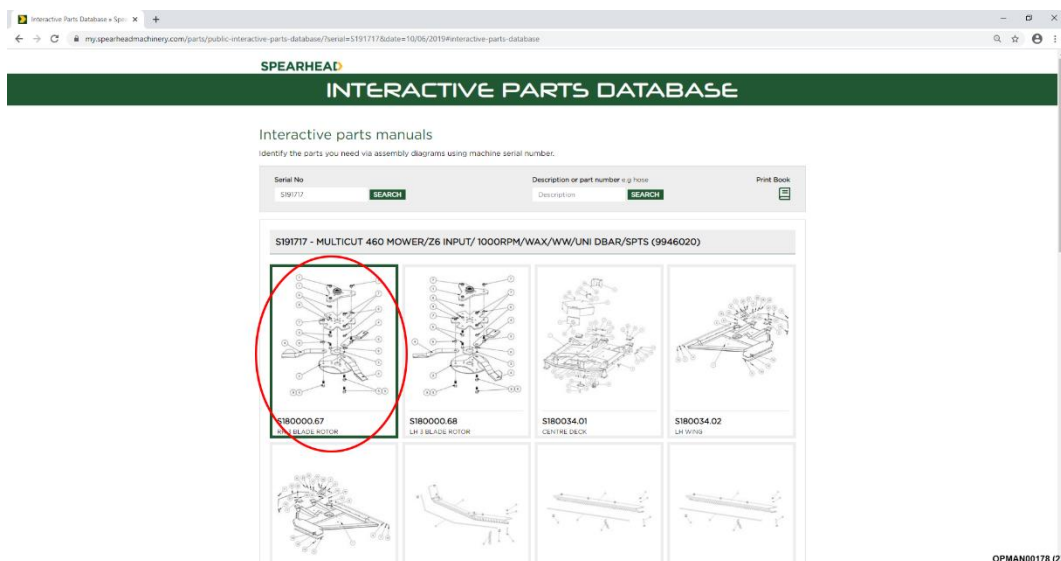

Figure 21 – Click On Assembly

- 7.1.1.4 You will finally be presented with a full exploded parts breakdown for that particular assembly, giving part numbers and the quantities required; see Figure 22.

The screenshot displays the 'Interactive Parts Database' interface. At the top, there is a search bar with 'Serial No' and 'Description or part number' fields. Below the search bar, a table lists the parts for an exploded view. The table has columns for 'Ref', 'Part No', 'Description', and 'QTY'. The parts listed are:

Ref	Part No	Description	QTY
1	1770602-342	CHIMBLADE CARRIER UPPER (100)	1
2	1770609	LOWER BLADE CARRIER (100)	1
3	1770604-3	SPACER	1
4	7770700	BLADE - RH C/W PIN 25	3
5	277045	BOLT	6
6	7770707	BLADE BUSH	6
7	277044	NUT	6
8	046053	CARRIER	1
9	2770464	WASHER	2

To the right of the table is an exploded view diagram of the assembly, with numbered callouts (1-9) corresponding to the parts in the BOM table. The interface also includes a 'Print Part List and diagram' button and a 'Print Book' icon.

Figure 22 – Exploded Parts Breakdown With Bill Of Materials

7.2 Spare Parts Ordering

It is important to note that when it comes to ordering replacement parts, that this can **only** be carried out through a Spearhead dealer. **Spearhead does not accept direct customer parts orders over email, fax or telephone.**

For guidance on finding your local Spearhead dealer; see Section 7.3.

7.3 Dealer Network

Spearhead has an extensive dealer network which can offer genuine replacement parts.

In order to make it easier to find your local Spearhead dealer, the Spearhead website has a Dealer Locator facility.

<http://www.spearheadmachinery.com/dealer-locator/>

To find your local Spearhead dealer enter your location or postcode into the “Your location” box and then press “Search”; see Figure 23.

The screenshot shows the 'DEALER LOCATOR' page on the Spearhead website. The search bar is labeled 'Your location' and contains the text 'Evesham', which is circled in red. Below the search bar, there is a map of the United Kingdom and surrounding regions (Ireland, Netherlands, Germany, Belgium). The map shows several green location markers. The search radius is set to 25 miles, and the results are 23. The website header includes the Spearhead logo and navigation links: Home, Products, Dealer Locator, About, Owners Hub, Used Machinery, News, Contact. The footer includes the text 'Tallis Ameer Group, Histon on the Green, Evesham, Worcestershire WR11 2QT, United Kingdom' and the reference code 'OPMAN00175'.

Figure 23 – Dealer Locator

Notes

Notes