

# Spearhead

## ROTARY DITCH CLEANER

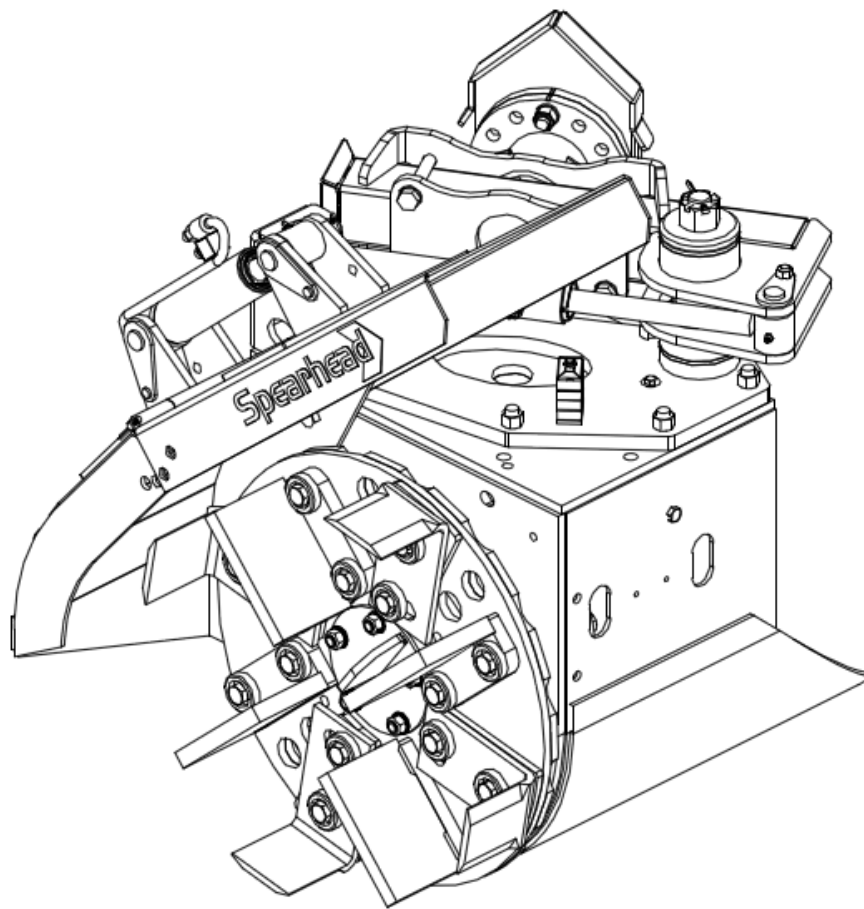

Edition 1.0 - Feb 2015  
Part No. 8999088

### HANDBOOK & PARTS MANUAL

# Spearhead Rotary Ditch Cleaner

## IMPORTANT

### VERIFICATION OF WARRANTY REGISTRATION



#### DEALER WARRANTY INFORMATION & REGISTRATION VERIFICATION

It is imperative that the selling dealer registers this machine with Spearhead Machinery Limited before delivery to the end user – failure to do so may affect the validity of the machine warranty.

To register machines go to the Spearhead Machinery Limited web site at [www.spearheadmachinery.com](http://www.spearheadmachinery.com), log onto 'Dealer Inside' and select the 'Machine Registration button' which can be found in the Service Section of the site. Confirm to the customer that the machine has been registered in the section below.

Should you experience any problems registering a machine in this manner please contact the Spearhead Service Department on 01789 491867.

#### Registration Verification

Dealer Name:	.....		
Dealer Address:	.....		
Customer Name:	.....		
Date of Warranty Registration:	...../...../.....	Dealer Signature:	.....

#### NOTE TO CUSTOMER / OWNER

Please ensure that the above section has been completed and signed by the selling dealer to verify that your machine has been registered with Spearhead Machinery Limited.

IMPORTANT: During the initial 'bedding in' period of a new machine it is the customer's responsibility to regularly inspect all nuts, bolts and hose connections for tightness and re-tighten if required. New hydraulic connections occasionally weep small amounts of oil as the seals and joints settle in – where this occurs it can be cured by re-tightening the connection – refer to torque settings chart below. The tasks stated above should be performed on an hourly basis during the first day of work and at least daily thereafter as part of the machines general maintenance procedure.

#### CAUTION: DO NOT OVER TORQUE HYDRAULIC FITTINGS AND HOSES

#### TORQUE SETTINGS FOR HYDRAULIC FITTINGS

HYDRAULIC HOSE ENDS		
BSP	Setting	Metric
1/4"	18 Nm	19 mm
3/8"	31 Nm	22 mm
1/2"	49 Nm	27 mm
5/8"	60 Nm	30 mm
3/4"	80 Nm	32 mm
1"	125 Nm	41 mm
1.1/4"	190 Nm	50 mm
1.1/2"	250 Nm	55 mm
2"	420 Nm	70 mm

PORT ADAPTORS WITH BONDED SEALS		
BSP	Setting	Metric
1/4"	34 Nm	19 mm
3/8"	47 Nm	22 mm
1/2"	102 Nm	27 mm
5/8"	122 Nm	30 mm
3/4"	149 Nm	32 mm
1"	203 Nm	41 mm
1.1/4"	305 Nm	50 mm
1.1/2"	305 Nm	55 mm
2"	400 Nm	70 mm

# Spearhead Rotary Ditch Cleaner

---

## WARRANTY POLICY

### WARRANTY REGISTRATION

All machines must be registered, by the selling dealer with Spearhead Machinery Ltd, before delivery to the end user. On receipt of the goods it is the buyer's responsibility to check that the Verification of Warranty Registration in the Operator's Manual has been completed by the selling dealer.

### 1. LIMITED WARRANTIES

- 1.01. All machines supplied by Spearhead Machinery Limited are warranted to be free from defects in material and workmanship from the date of sale to the original purchaser for a period of 12 months, unless a different period is specified.
- 1.02. All spare parts supplied by Spearhead Machinery Limited are warranted to be free from defects in material and workmanship from the date of sale to the original purchaser for a period of 6 months.
- 1.03. The manufacturer will replace or repair for the purchaser any part or parts found, upon examination at its factory, to be defective under normal use and service due to defects in material or workmanship. Returned parts must be complete and unexamined.
- 1.04. This warranty does not apply to any part of the goods, which has been subjected to improper or abnormal use, negligence, alteration, modification, fitment of non-genuine parts, accident damage, or damage resulting from contact with overhead power lines, damage caused by foreign objects (e.g. stones, iron, material other than vegetation), failure due to lack of maintenance, use of incorrect oil or lubricants, contamination of the oil, or which has served its normal life. This warranty does not apply to any expendable items such as blades, flails, bushes, belts, flap kits, skids, shields, guards, wear pads or pneumatic tyres.
- 1.05. Temporary repairs and consequential loss - i.e. oil, downtime and associated parts are specifically excluded from the warranty.
- 1.06. Warranty on hoses is limited to 12 months and does not include hoses which have suffered external damage. Only complete hoses may be returned under warranty, any which have been cut or repaired will be rejected.
- 1.07. Machines must be repaired immediately a problem arises. Continued use of the machine after a problem has occurred can result in further component failures, for which Spearhead Machinery Ltd cannot be held liable, and may have safety implications.
- 1.08. Except as provided herein, no employee, agent, dealer or other person is authorised to give any warranties of any nature on behalf of Spearhead Machinery Ltd.
- 1.09. For machine warranty periods in excess of 12 months the following additional exclusions shall apply:
  - 1.09.1. Hoses, external seals, exposed pipes and hydraulic tank breathers.
  - 1.09.2. Filters
  - 1.09.3. Rubber mountings
  - 1.09.4. External electric wiring.
  - 1.09.5. Labour and mileage costs.
- 1.10. All service work, particularly filter changes, must be carried out in accordance with the manufacturer's service schedule. Failure to comply will invalidate the warranty. In the event of a claim, proof of the service work being carried out may be required.

*NB Warranty cover will be invalid if any non-genuine parts have been fitted or used. Use of non-genuine parts may seriously affect the machine's performance and safety. Spearhead Machinery Ltd cannot be held responsible for any failures or safety implications that arise due to the use of non-genuine parts.*

# Spearhead Rotary Ditch Cleaner

---

## 2. REMEDIES AND PROCEDURES

- 2.01. The warranty is not effective unless the Selling Dealer registers the machine, via the Spearhead Machinery web site and confirms the registration to the purchaser by completing the confirmation form in the operator's manual.
- 2.02. Any fault must be reported to an authorised Spearhead Machinery dealer as soon as it occurs. Continued use of a machine, after a fault has occurred, can result in further component failure for which Spearhead Machinery Ltd cannot be held liable.
- 2.03. Repairs should be undertaken within two days of the failure. Claims submitted for repairs undertaken more than 2 weeks after a failure has occurred, or 2 days after the parts were supplied will be rejected, unless the delay has been authorised by Spearhead Machinery Ltd.
- 2.04. All claims must be submitted, by an authorised Spearhead Machinery Service Dealer, within 30 days of the date of repair.
- 2.05. Following examination of the claim and parts the manufacturer will pay, at their discretion, for any valid claim the cost of any parts and an appropriate labour allowance if applicable.
- 2.06. The submission of a claim is not a guarantee of payment.
- 2.07. Any decision reached by Spearhead Machinery Ltd is final.

## 3. LIMITATION OF LIABILITY

- 3.01. The manufacturer disclaims any express (except as set forth herein) and implied warranties with respect to the goods including, but not limited to, merchantability and fitness for a particular purpose.
- 3.02. The manufacturer makes no warranty as to the design, capability, capacity or suitability for use of the goods.
- 3.03. Except as provided herein, the manufacturer shall have no liability or responsibility to the purchaser or any other person or entity with respect to any liability, loss, or damage caused or alleged to be caused directly or indirectly by the goods including, but not limited to, any indirect, special, consequential, or incidental damages resulting from the use or operation of the goods or any breach of this warranty. Notwithstanding the above limitations and warranties, the manufacturer's liability hereunder for damages incurred by the purchaser or others shall not exceed the price of the goods.
- 3.04. No action arising out of any claimed breach of this warranty or transactions under this warranty may be brought more than one (1) year after the cause of the action has occurred.

## 4. MISCELLANEOUS

- 4.01. The manufacturer may waive compliance with any of the terms of this limited warranty, but no waiver of any terms shall be deemed to be a waiver of any other term.
- 4.02. If any provision of this limited warranty shall violate any applicable law and is held to be unenforceable, then the invalidity of such provision shall not invalidate any other provisions herein.
- 4.03. Applicable law may provide rights and benefits to the purchaser in addition to those provided herein.

# Spearhead Rotary Ditch Cleaner

---

## CE Declaration of Conformity, Conforming to EU Machinery Directive 2006/42/EC

We, Spearhead Machinery Ltd, Green View, Salford Priors, Evesham,  
Worcestershire, WR11 8SW hereby declare that:

*Product*.....  
*Product Code*.....  
*Serial No*.....  
*Type*.....

Manufactured by: Alamo Manufacturing Services (UK) Limited, Station Road,  
Salford Priors, Evesham, Worcestershire, WR11 8SW

Complies with the required provisions of the Machinery Directive 2006/42/EC.  
The Machinery Directive is supported by the following harmonized standards:

- BS EN ISO 14121-1 (2007) Safety of Machinery – Risk Assessment, Part 1: Principles Part 2: Practical Guide and Examples of Methods.
- BS EN ISO 12100-1 (2010) Safety of Machinery – Part 1: Basic Terminology and Methodology Part 2: Technical Principles.
- BS EN 349 (1993) + A1 (2008) Safety of Machinery – Minimum Distances to avoid the Entrapment of Human Body Parts.
- BS EN 953 (1998) Safety of Machinery – Guards General Requirements for the Design and Construction of Fixed and Movable Guards.
- BS EN 982 (1996) + A1 (2008) Safety Requirements for Fluid Power Systems and their Components. Hydraulics.

The EC Declaration only applies if the machine stated above is used in  
accordance with the operating instructions.

*Signed*



(On behalf of Spearhead Machinery Ltd)

*Status*

General Manager

*Date*

.....

# Spearhead Rotary Ditch Cleaner

---

## Contents

General Information.....	7
Safety Information.....	8
Additional Safety Advice.....	12
Flows and Pressures.....	13
Fitting.....	13
Cross Port Relief Valve Kit.....	15
Operation.....	16
Maintenance.....	17
Overhead Power Lines.....	19
Parts Book Contents.....	21

# Spearhead Rotary Ditch Cleaner

---

## General Information

Read this manual before fitting or operating the machine. Whenever any doubt exists contact your dealer or the Spearhead Service Department for assistance.

**Use only use Spearhead Genuine Parts on Spearhead equipment and machines.**

DEFINITIONS The following definitions apply throughout this manual:

### WARNING:

An operating procedure, technique etc., which can result in personal injury or loss of life if not observed carefully.

### CAUTION:

An operating procedure, technique etc., which can result in the damage of either machine or equipment if not observed carefully.

### NOTE:

An operating procedure, technique etc., which is considered essential to emphasise.

### LEFT AND RIGHT HAND:

This term is applicable to the machine when fitted to the tractor and viewed from the rear.

This also applies to tractor references.

## MACHINE & DEALER INFORMATION

*Record the Serial Number of your machine on this page and always quote this number when ordering parts. Whenever information concerning the machine is requested remember to also state the make and model of tractor to which the machine is fitted.*

<b>Machine Serial Number:</b>	<b>Installation Date:</b>
<b>Machine Model details:</b>	
<b>Dealer Name:</b>	
<b>Dealer Address:</b>	
<b>Dealer Telephone No:</b>	
<b>Dealer Email Address:</b>	

# Spearhead Rotary Ditch Cleaner

---

## Safety Information



## SAFETY INFORMATION

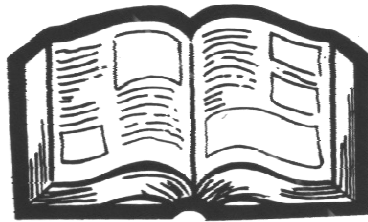



# Spearhead Rotary Ditch Cleaner

---

This machine has the potential to be extremely dangerous, in the wrong hands it can kill or maim. It is therefore imperative that the owner, and the operator of this machine, read the following section to ensure that they are both fully aware of the dangers that do, or may exist, and their responsibilities surrounding its use.

The operator of this machine is responsible not only for their own safety but equally for the safety of others who may come into the close proximity of the machine, as the owner you are responsible for both.

## **POTENTIAL SIGNIFICANT DANGERS ASSOCIATED WITH THE USE OF THIS MACHINE:**

- ▲ *Being hit by debris thrown by rotating components.*
- ▲ *Being hit by machine parts ejected through damage during use.*
- ▲ *Being caught on a rotating power take-off (PTO) shaft.*
- ▲ *Being caught in other moving parts i.e.: belts, pulleys and cutting heads.*
- ▲ *Electrocution from Overhead Power Lines (by contact with or 'flashover' from).*
- ▲ *Being hit by cutting heads or machine arms as they move.*
- ▲ *Becoming trapped between tractor and machine when hitching or unhitching.*
- ▲ *Tractor overbalancing when machine arm is extended.*
- ▲ *Injection of high pressure oil from hydraulic hoses or couplings.*
- ▲ *Machine overbalancing when freestanding (out of use).*
- ▲ *Road traffic accidents due to collision or debris on the road.*

## **BEFORE USING THIS MACHINE YOU MUST:**

- ▲ *Ensure you read all sections of the operator handbook.*
- ▲ *Ensure the operator is, or has been, properly trained to use the machine.*
- ▲ *Ensure the operator has been issued with and reads the operator handbook.*
- ▲ *Ensure the operator understands and follows the instructions in operator handbook.*
- ▲ *Ensure the tractor front, rear and side(s) are fitted with metal mesh or polycarbonate guards of suitable size and strength to protect the operator against thrown debris or parts.*
- ▲ *Ensure tractor guards are fitted correctly, are undamaged and kept properly maintained.*
- ▲ *Ensure that all machine guards are in position, are undamaged, and are kept maintained in accordance with the manufacturer's recommendations.*

# Spearhead Rotary Ditch Cleaner

---

- ▲ *Ensure flails and their fixings are of a type recommended by the manufacturer, are securely attached and that none are missing or damaged.*
- ▲ *Ensure hydraulic pipes are carefully and correctly routed to avoid damage by chaffing, stretching or pinching and that they are held in place with the correct fittings.*
- ▲ *Always follow the manufacturer's instructions for attachment and removal of the machine from the tractor.*
- ▲ *Check that the machine fittings and couplings are in good condition.*
- ▲ *Ensure the tractor meets the minimum weight recommendations of the machine manufacturer and that ballast is used as necessary.*
- ▲ *Always inspect the work area thoroughly before starting to note obstacles and remove wire, bottles, cans and other debris.*
- ▲ *Use clear suitably sized warning signs to alert others to the nature of the machine working within that area. Signs should be placed at both ends of the work site. (It is recommended that signs used are of a size and type specified by the Department of Transport and positioned in accordance with their and the Local Highways Authority guidelines).*
- ▲ *Ensure the operator is protected from noise. Ear defenders should be worn and tractor cab doors and windows must be kept closed. Machine controls should be routed through proprietary openings in the cab to enable all windows to be shut fully.*
- ▲ *Always work at a safe speed taking account of the conditions i.e.: terrain, highway proximity and obstacles around and above the machine.*
- ▲ *Extra special attention should be applied to Overhead Power Lines. Some of our machines are capable of reach in excess of 8 metres (26 feet) this means they have the potential to well exceed, by possibly 3 metres (9' 9"), the lowest legal minimum height of 5.2 metres from the ground for 11,000 and 33,000 volt power lines. It cannot be stressed enough the dangers that surround this capability, it is therefore vital that the operator is fully aware of the maximum height and reach of the machine, and that they are fully conversant with all aspects regarding the safe minimum distances that apply when working with machines in close proximity to Power Lines. (Further information on this subject can be obtained from the Health & Safety Executive or your Local Power Company).*
- ▲ *Always disengage the machine, kill the tractor engine, remove and pocket the key before dismounting for any reason.*
- ▲ *Always clear up all debris left at the work area, it may cause hazard to others.*
- ▲ *Always ensure when you remove your machine from the tractor that it is left in a safe and stable position using the stands and props provided and secured if necessary.*

# Spearhead Rotary Ditch Cleaner

---

## WHEN NOT TO USE THIS MACHINE:

- ▲ *Never attempt to use this machine if you have not been trained to do so.*
- ▲ *Never uses a machine until you have read and understood the operator handbook, are familiar with, and practiced the controls.*
- ▲ *Never use a machine that is poorly maintained.*
- ▲ *Never use a machine if guards are missing or damaged.*
- ▲ *Never use a machine on which the hydraulic system shows signs of wear or damage.*
- ▲ *Never fit, or use, a machine on a tractor that does not meet the manufacturer's minimum specification level.*
- ▲ *Never use a machine fitted to a tractor that does not have suitable front, rear and side(s) cab guarding made of metal mesh or polycarbonate.*
- ▲ *Never use the machine if the tractor cab guarding is damaged, deteriorating or badly fitted.*
- ▲ *Never turn a machine cutting head to an angle that causes debris to be ejected towards the cab.*
- ▲ *Never start or continue to work a machine if people are nearby or approaching - Stop and wait until they are at a safe distance before continuing.*
- ▲ *Never attempt to use a machine on materials in excess of its capability.*
- ▲ *Never use a machine to perform a task it has not been designed to do.*
- ▲ *Never operate the tractor or machine controls from any position other than from the driving seat, especially whilst hitching or unhitching the machine.*
- ▲ *Never carry out maintenance of a machine or a tractor whilst the engine is running – the engine should be switched off, the key removed and pocketed.*
- ▲ *Never leave a machine unattended in a raised position – it should be lowered to the ground in a safe position on a level firm site.*
- ▲ *Never leave a tractor with the key in or the engine running.*
- ▲ *Never carry out maintenance on any part or component of a machine that is raised unless that part or component has been properly substantially braced or supported.*
- ▲ *Never attempt to detect a hydraulic leak with your hand – use a piece of cardboard.*
- ▲ *Never allow children near to, or play on, a tractor or machine under any circumstances.*

# Spearhead Rotary Ditch Cleaner

---

## Additional Safety Advice

### TRAINING

Operators need to be competent and fully capable of operating this machine in a safe and efficient way prior to attempting to use it in any public place. We advise therefore that the prospective operator make use of relevant training courses available such as those run by the Agricultural Training Board, Agricultural Colleges, Dealers and Spearhead.

### WORKING IN PUBLIC PLACES

When working in public places such as roadsides, consideration should be paid to others in the vicinity. Stop the machine immediately when pedestrians, cyclists and horse riders etc. pass. Restart only when they are at a distance that causes no risk to their safety.

### WARNING SIGNS

It is advisable that any working area be covered by suitable warning signs and statutory in public places. Signs should be highly visible and well placed in order to give clear advanced warning of the hazard. Contact the Department of Transport or your Local Highways Authority to obtain detailed information on this subject. The latter should be contacted prior to working on the public highway advising them of the time and location of the intended work asking what is required by way of signs and procedure. – *'Non-authorised placement of road signs may create offences under the Highways Act'*.

### SUGGESTED WARNING SIGNS REQUIRED

*"Road works ahead" warning sign with a supplementary "Hedge cutting" plate. "For 1 mile" or appropriate shorter distance may be added to the plate.*

*"Road narrows" warning sign with supplementary "Single file traffic" plate.*

*White on blue "Keep right" arrow sign on rear of machine.*

### USE OF WARNING SIGNS

- ▲ *On two way roads one set of signs is needed facing traffic in each direction.*
- ▲ *Work should be within 1 mile of the signs.*
- ▲ *Work only when visibility is good and at times of low risk e.g.: NOT during 'rush-hour'.*
- ▲ *Vehicles should have an amber flashing beacon.*
- ▲ *Ideally, vehicles should be conspicuously coloured.*
- ▲ *Debris should be removed from the road and path as soon as practicable, and at regular intervals, wearing high visibility clothing and before removing the hazard warning signs.*
- ▲ *Collect all road signs promptly when the job is completed.*

---

**Although the information given here covers a wide range of safety subjects it is impossible to predict every eventuality that can occur under differing circumstances whilst operating this machine. No advice given here can replace 'good common sense' and 'total awareness' at all times but will go a long way towards the safe use of your Spearhead machine.**

---

# Spearhead Rotary Ditch Cleaner

---

## Flows and Pressures

<b>STANDARD SPEED VERSION</b>	-		<b>TWIGA MID</b>	<b>TWIGA PRO</b>
<i>Maximum continuous flow</i>	-	125 L/min	540 PTO MAX	540 PTO MAX
<i>Maximum continuous speed</i>	-	320RPM		
<i>Maximum continuous pressure</i>	-	210 Bar		
	-			
	-			
<b>OPERATING CONDITIONS FOR BOTH VERSIONS</b>				
<i>Return line pressure</i>	-	2 Bar min to 20 Bar max*		
<i>Maximum drain line pressure</i>	-	5 Bar		
<i>Optimum Viscosity</i>	-	35 – 200cSt		
<i>Optimum temperature</i>	-	40 - 70°C		
<i>Fluid Cleanliness</i>	-	NAS 9/ ISO 18/15		

**\* On non electric rotor control valve or non piston machines a Back Pressure Kit should be fitted or motor life will be seriously reduced.**

## FITTING

---

The Rotary Ditcher and Rotary Cleaner can be fitted only to Power Arm machines that are equipped with hydraulic slewing/breakaway action.

The procedure for fitting the units is as follows;

### Flailhead Removal

- Disconnect the flailhead hoses on both sides of the hose junction bracket.
- Unbolt the hose junction bracket from the angling jaw plate.
- Unbolt the flailhead from the mounting tube and remove together with the hoses and the junction bracket - *plug or cover the ends of the hoses to prevent access of contaminants during storage.*

### Fitting of Ditcher/Cleaner Unit

- Bolt the Ditcher/Cleaner to the dipper arm ensuring that the top plate is horizontal when the angling ram is approximately half extended - *i.e. at the mid-point of its stroke.*

On machines with piston hydraulics connect 'T' connection to the drain line on the machine or connect motor drain line as supplied in the kit (*see below*).

# Spearhead Rotary Ditch Cleaner

## Using Drain Line Supplied with the Kit

- If using the drain line supplied with the kit the hose guards should be removed from the Power Arms and the  $\frac{3}{8}$ " BSP drain hose from the Ditcher/Cleaner secured alongside, and attached to, the existing Power Arm hoses using the hose ties supplied.  
Note: - *Ensure that that sufficient 'slack' is allowed for over the arm pivots to permit the hoses to flex properly.*
- Refit hose guards.
- Unscrew the breather from the tank top and remove the 'O' ring from the union.
- Fit the  $\frac{3}{4}$ " BSP M/F adaptor onto the breather union together with the  $\frac{3}{4}$ " BSP bonded washer supplied.
- Refit the breather using the existing 'O' ring.
- Screw the  $\frac{3}{4}$ " BSP M/M union into the side of the breather extended adaptor using the  $\frac{3}{4}$ " BSP bonded washer supplied.
- Connect the motor drain hose.
- Connect up the 1" BSP hoses to the existing flail hoses using the 1" BSP union provided to give the rotation of cut required – see *diagram below*.

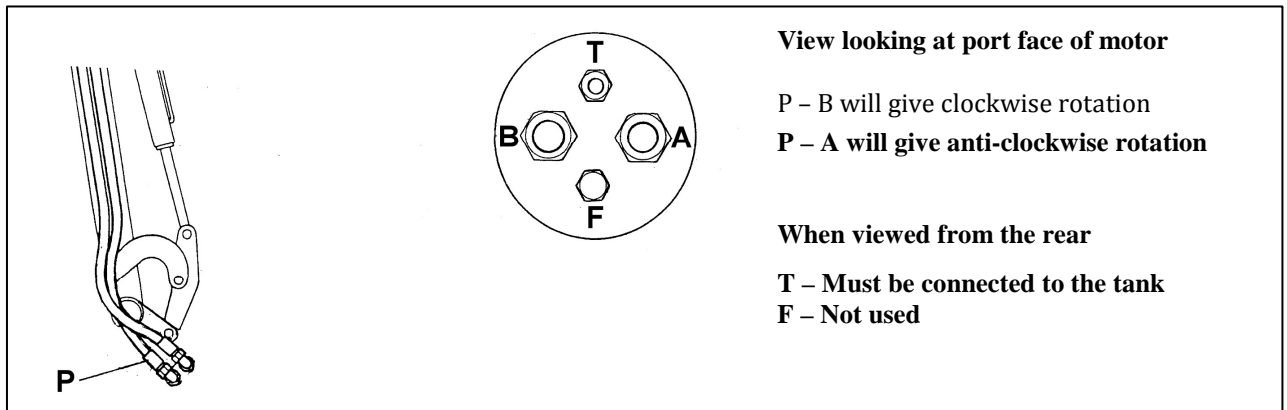

## BACK PRESSURE KIT - *Gear Hydraulic machines only*

**Note: Electric Reverse Gear and Piston Machines DO NOT require a Back Pressure Kit.**

A Back Pressure Kit is provided to prevent the motor from becoming 'starved' of oil during normal operation and whilst stopping and starting. The kit must be fitted in the return line hose from the motor and normally fits directly onto the motor control valve. This installation is as follows:

- The tank return 'T' (*complete with hose*) is disconnected from the valve, the back pressure valve is fitted onto the union and the 'T' reconnected onto the free end of the back pressure valve.
- Disconnect the pressure hose from the pump, fit the 1" BSP 'T' piece to the pressure port adaptor and reconnect the pressure hose.
- Complete the installation by joining the back pressure valve and the pressure line 'T' using the  $\frac{1}{4}$ " hose provided.

NOTE: *This installation allows the operator to select opposite rotation to clear a blockage.*

**CAUTION**  
**On reverting back to hedgecutting/mowing the Back Pressure Kit MUST BE REMOVED**

# Spearhead Rotary Ditch Cleaner

## Cross Port Relief Valve Kit

### CROSS PORT RELIEF VALVE KIT (Option)

Required for units fitted to Power Arms with 85HP hydraulic system.

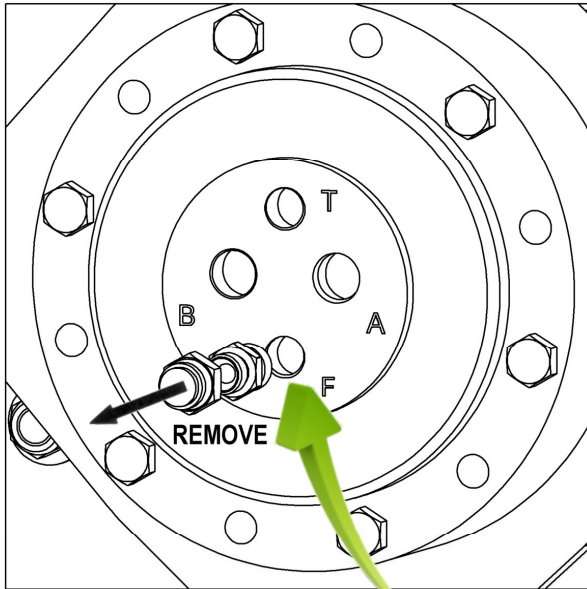

REPLACE WITH  
O-Ring Seal 8600908  
& Drain Plug 8581587

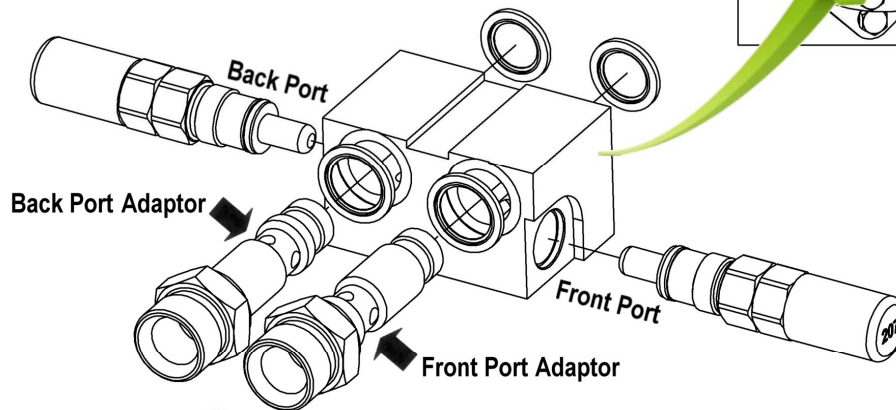
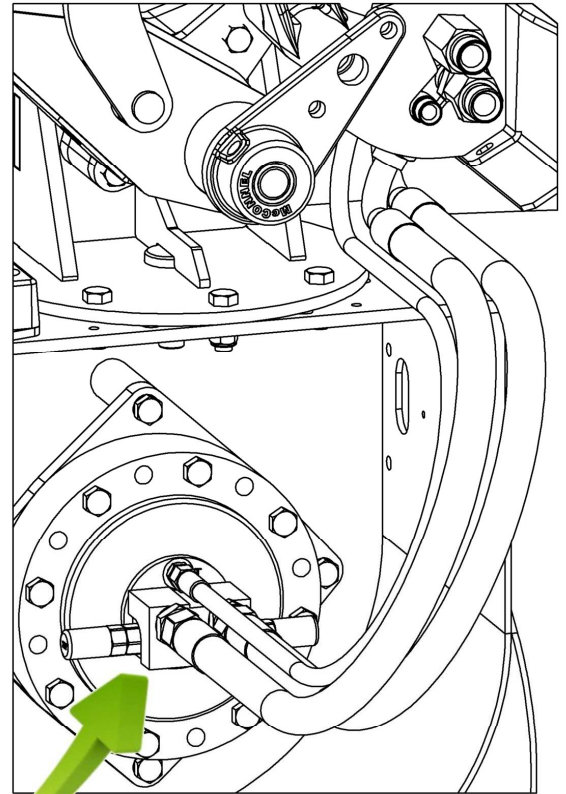

ENSURE CORRECT ADAPTOR IS FITTED TO THE CORRECT VALVE PORT  
CROSS DRILLED PORTS IN ADAPTOR MUST ALIGN WITH RELIEF VALVE

# Spearhead Rotary Ditch Cleaner

---

## Operation

### Read the Book First

Before attempting to operate this machine it is imperative that both the owner and operator has read, and fully understood, not only this manual but also that of any machine it is attached to, and that they are fully conversant with all operation and safety aspects surrounding its use.

- Check all nuts and bolts are tight and that the 1" BSP hose connections give the desired rotation of cut when the lever is operated such: -

- - Upward Cutting = Clockwise Rotation**
    - Downward Cutting = Anti-clockwise Rotation**
- } *When viewed from the front*

*If found to be opposite to above the 1" BSP hoses must be interchanged at the jointing union.*

- Examine the ditch for obstacles and dangerous materials e.g. metal, wire, glass, large stones etc. and remove before commencing.

### ADJUSTMENTS

#### Approach Angle

The Ditch Cleaner can be rotated on its mounting plate to give 5 approach angles to the ditch - this is achieved by removing the 3 mounting bolts enabling the main body to be pivoted about its central spindle to the required position.

#### Cutters

The double-edged blades and paddles can be adjusted to allow cutting with either a clockwise or anti-clockwise rotation - if using single-edged blades an opposite hand set of blades will be needed if it is required to cut with the opposite rotation.

#### Blades

The double-edged blades, which are slotted, pivot about the outer mounting bolt to allow for rotation of cut. For anti-clockwise cutting action (*when viewed from the front*) the blade is pivoted clockwise to the limit of the slot and visa-versa.

Blade options include:

Double edged blade (*Part No. 41.216.01*) – Good cutting performance in harder soils

Single edged blade (*Part No. 41936.01*) – L/H Standard Duty – good throwing performance.

Single edged blade (*Part No. 41936.02*) – R/H Standard Duty – good throwing performance.

Single edged blade (*Part No. 41936.03*) – L/H Heavy Duty – good throwing performance.

Single edged blade (*Part No. 41936.04*) – R/H Heavy Duty – good throwing performance.

**NOTE: Blades should be fitted in sets of 3 and be of similar weight in order to maintain rotor balance.**

#### Paddles

The function of the paddles is to aid the excavation of material from the cutting area. There are 2 possible positions available for mounting the paddles; the correct position will depend on the direction of cut – whichever the direction, the paddles should always be fitted with the paddle face leading and the paddle body sloping backwards from the rotation of cut.

#### Spoil Deflector

The spoil deflector consists of two sections, the first is fixed whilst the second pivots to allow a choice of 8 positions to control and guide the direction of thrown spoil. The adjustments allow the angle of cut and the outboard destination of the spoil to be selected for both right and left hand mounted machines. To deflect the spoil inboard a reverse chute and blade kit is available.



# Spearhead Rotary Ditch Cleaner

---

## Maintenance

### Ditch Cleaner Shaft Seal Replacement

1. Slacken evenly, the eight bolts (*item 330*) to release the output housing from the torque unit. NOTE THE ORIENTATION OF THE HOUSING TO THE TORQUE UNIT.
2. Carefully lift off the output housing taking care not to disturb the rotor in the torque unit when disengaging the spline drive.
3. Unlock washer (*item 270*) and release the nut (*item 260*) which holds the bearing under pre-load, remove both.
4. Supporting the housing (*item 160*) press the shaft out from the splined end. This will remove the cone of the inner bearing (*item 240*) from the shaft.
5. Remove from housing the bearing cone from the inner bearing (*item 240*).
6. Remove the shaft seal (*item 280*).
7. Clean all parts thoroughly.

### Re-Assembly

1. Press a new shaft seal (*item 280*) carefully and squarely into the output housing (*item 160*).
2. Press the bearing cup from the inner bearing (*item 240*) back into its bore in the housing, taking care to ensure it faces the correct way.
3. Fill the area between the end of the housing and the shaft seal with lithium based grease as stated on the attached assembly drawing.
4. Holding the keyed end of the shaft (*item 200*) vertically in a vice, lower the output housing onto it so that it sits squarely on the outer bearing (*item 230*).
5. Warm slightly, the inner bearing cone to help with assembly, then press it on to the shaft until it sits in the cone, ensuring that the bearing is installed the correct way.
6. Re-fit the locking tab and the locking nut and tighten the unit to 24-lbf ft.
7. Re-fit the locking tab. If the tab does not line up with any slot in the nut, tighten the nut to line up a tab with a slot in the nut.
8. Spin the housing to ensure the bearings are seated correctly and that there is no end play on them.
9. Check the 'O' ring (*item 300*) in the housing face is O K, then lower it onto the torque unit, taking care to align the splines correctly and that the output housing to the torque unit orientation is as it was before stripdown.
10. Re-fit and tighten evenly, the eight bolts (*item 330*). Check regularly during tightening that the shaft is free to rotate, thus ensuring that the alignment of the output housing and torque unit is correct.
11. Tighten the eight bolts to the recommended torque setting (*see diagram on following page*).

# Spearhead Rotary Ditch Cleaner

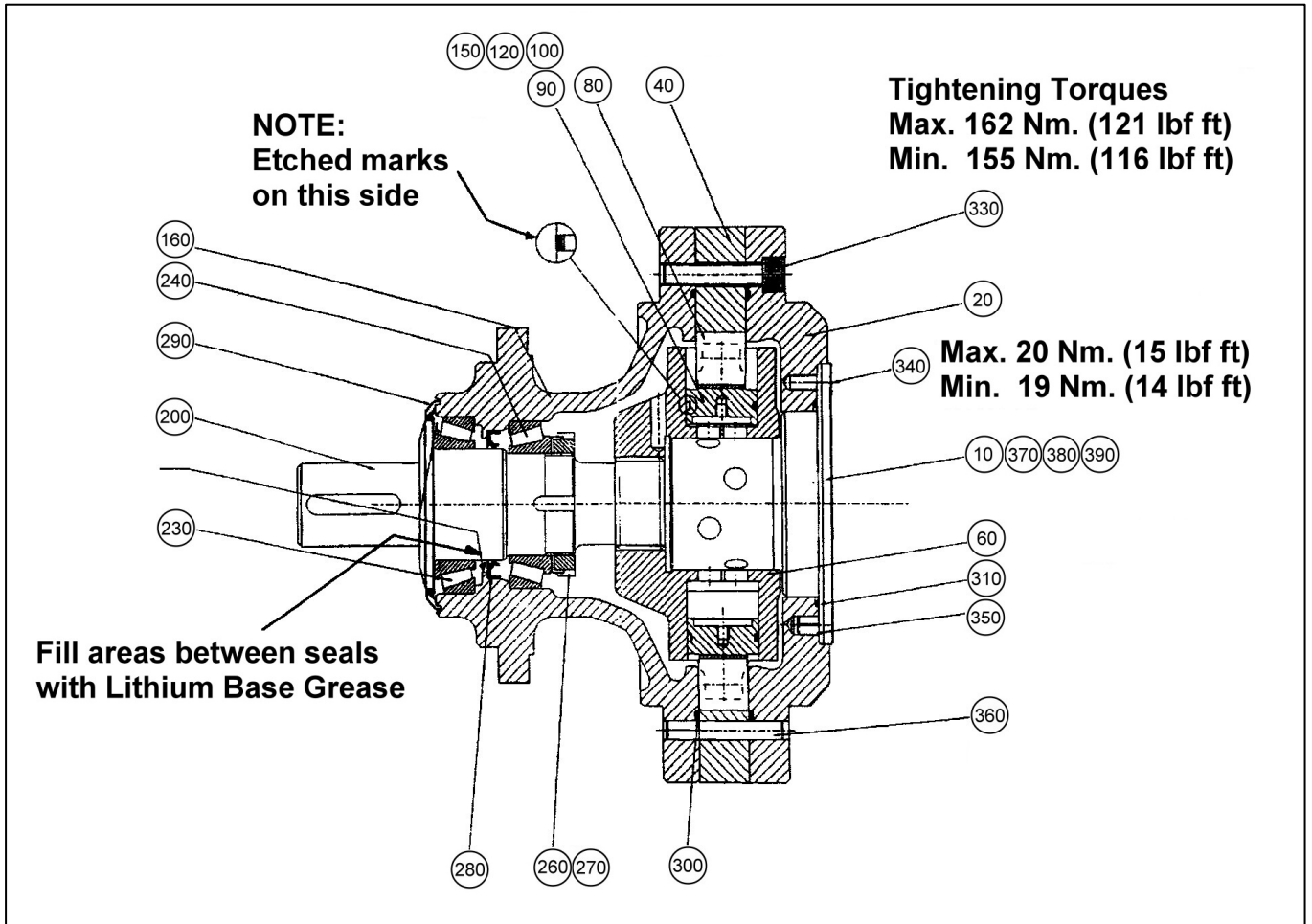

# Spearhead Rotary Ditch Cleaner

## Overhead Power Lines

It cannot be stressed enough the dangers involved when working in the vicinity of Overhead Power Lines (OHPLs). Some of our machines are capable of reach in excess of 8 metres (26'); they have the potential to well exceed, by possibly 3 metres (9' 9"), the lowest legal minimum height of 5.2 metres from the ground for 11,000 and 33,000 volt power lines.

Remember electrocution can occur without actually coming into contact with a power line as electricity can 'flashover' when machinery gets close to it.



**WARNING: All operators must read the following information and be aware of the risks and dangers involved when working in the vicinity of Overhead Power Lines (OHPLs).**

Wherever possible the safest option is always to avoid working in areas close to OHPLs. Where unavoidable, all operators must perform a risk assessment and implement a safe procedure and system of work – see following page for details.

All operators should perform a risk assessment before operating the machine within 10m horizontal distance of any OHPLs.

### Minimum Heights for Overhead Power Lines

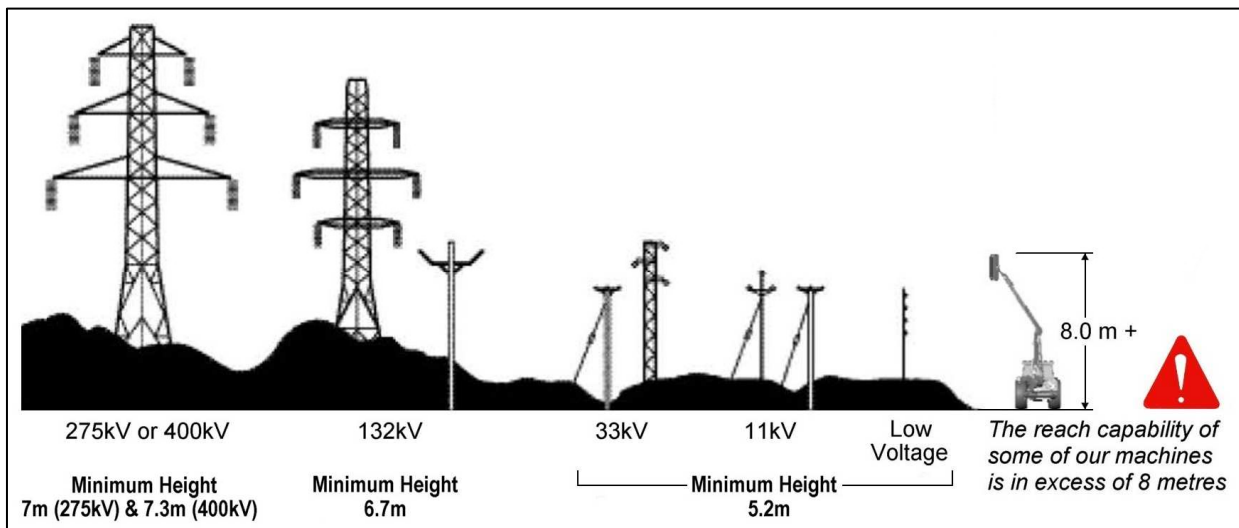

### Absolute Minimum Exclusion Zones for Specific Overhead Power Lines

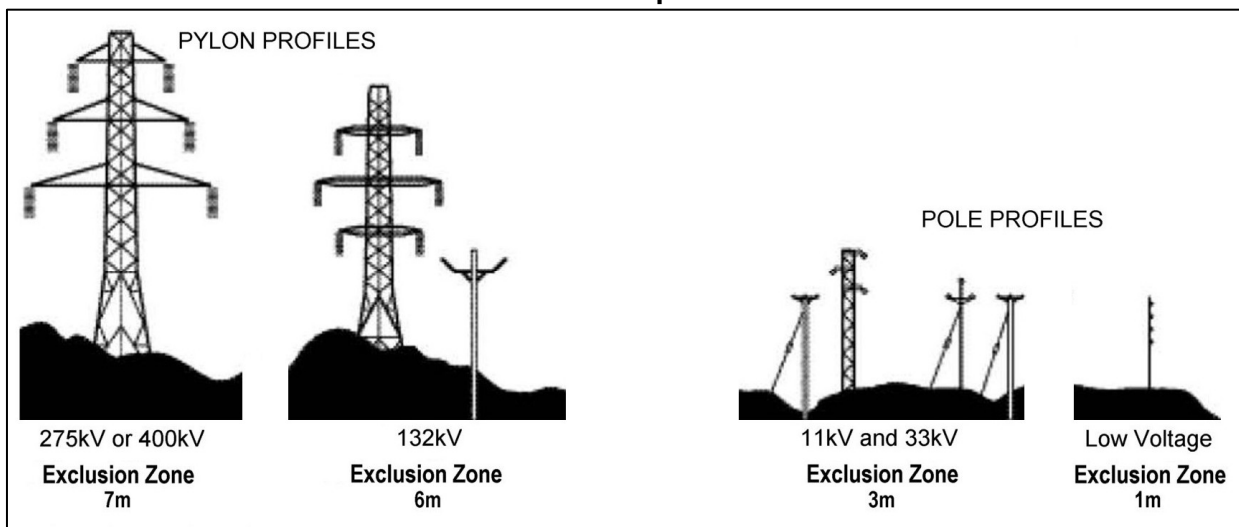

# Spearhead Rotary Ditch Cleaner

## Definitions of Exclusion Zones

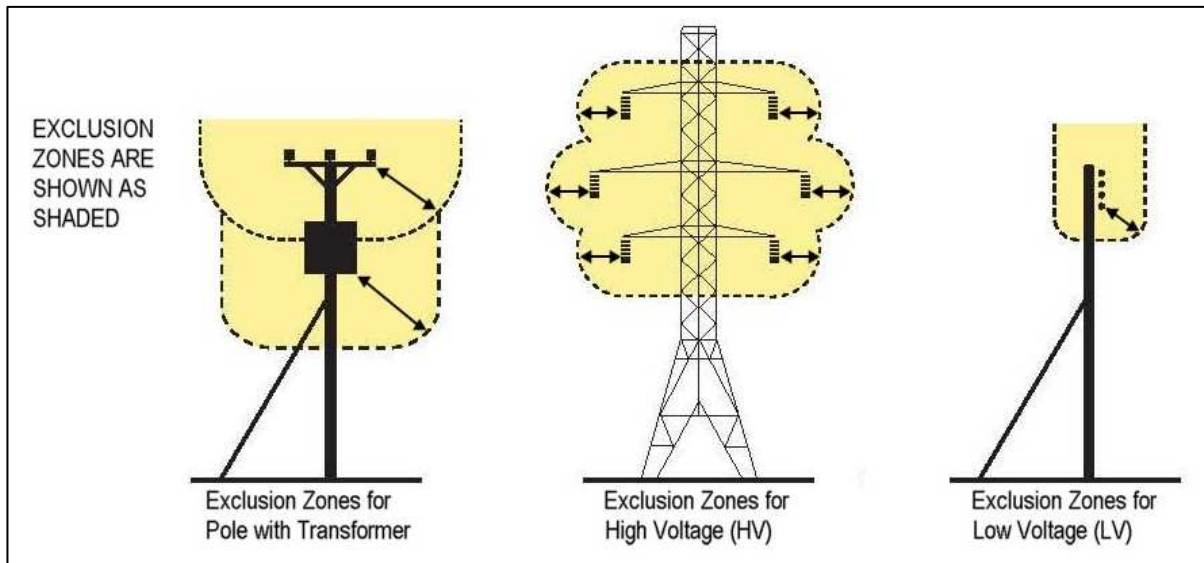

### Risk Assessment

Before starting to work near OHPLs you should always assess the risks. The following points should be observed;

**Know** the risks of contacting OHPLs and the risk of flashover.

**Find out** the maximum height and maximum vertical reach of your machine.

**Find out** the location and route of all Power Lines within the work area.

**Find out** the operating voltage of all Power Lines within the work area.

**Contact** the local Distribution Network Operator (DNO) who will be able to advise you on the operating voltage, safe minimum clearance distance for working and additional precautions required.

**Never** attempt operate the machine in an exclusion zones.

**Always** work with extreme caution and plan your work ahead to avoid high risk areas.

**If doubt exists** do not work in the area – never risk the safety of yourself or others.

### Emergency Action for Accidents Involving Electricity

- Never touch an overhead line - even if it has been brought down by machinery, or has fallen. Never assume lines are dead.
- When a machine is in contact with an overhead line, electrocution is possible if anyone touches both the machine and the ground. Stay in the machine and lower any raised parts in contact or drive the machine out of the lines if you can.
- If you need to get out to summon help or because of fire, jump out as far as you can without touching any wires or the machine - keep upright and away.
- Get the electricity company to disconnect the supply. Even if the line appears dead, do not touch it - automatic switching may reconnect the power.

Further information and leaflets on this and other agricultural safety subjects are available on the 'Health & Safety Executive' website at the following address:

[www.hse.gov.uk/pubns/agindex.htm](http://www.hse.gov.uk/pubns/agindex.htm)

# Spearhead Rotary Ditch Cleaner

---

## Parts Book Contents

Ordering Your Parts.....	22
6600944 – Rotary Ditcher Assembly LH Build.....	23
6600945 – Rotary Ditcher Assembly LH Build.....	24
6600946 – Rotary Ditcher Assembly RH Build.....	25
6600947 – Rotary Ditcher Assembly RH Build.....	26
6600764 – Hydraulic Cute LH Build.....	27
6600766 – Hydraulic Cute RH Build.....	28
6600769 – Cutting Disc/Blade Assembly.....	29
6600702 – Motor Module.....	31
6600733/734 – Hyd Rotation Module LH/RH.....	32
6600746 – Hydraulic Installation Module.....	34
6600744 – Hydraulic Installation Module.....	35
42949.01 – Back Pressure Valve Kit.....	37
23067.03 – Hydraulic Hose Kit.....	39
23067.02 – Hydraulic Hose Kit.....	40
6600765 – Relief Valve Kit.....	41

# Spearhead Rotary Ditch Cleaner

---

## Ordering Your Part's

When ordering parts please refer to your parts list to help your dealer with your order.

Part number and quantity  
Description  
Machine model number  
Serial number of the machine  
Delivery instructions (e.g. next day).

Delivery is normally via carrier direct to your dealer. Please check with your dealer for stock availability and arrangement of dispatch. Ensure you or your dealer has sufficient cover for parts requirement outside factory hours.

When ordering your seal kits please quote both codes stamped on the base of the cylinder.

### Important Note

The information contained in this manual is correct at the time of publication. However, in the course of constant development, changes in specification are inevitable. Should you find the information given in this book different to the machine it relates to, please contact the "After Sales Department" for advice.

### Key:

(LH) = Left hand  
(RH) = Right hand

# Spearhead Rotary Ditch Cleaner

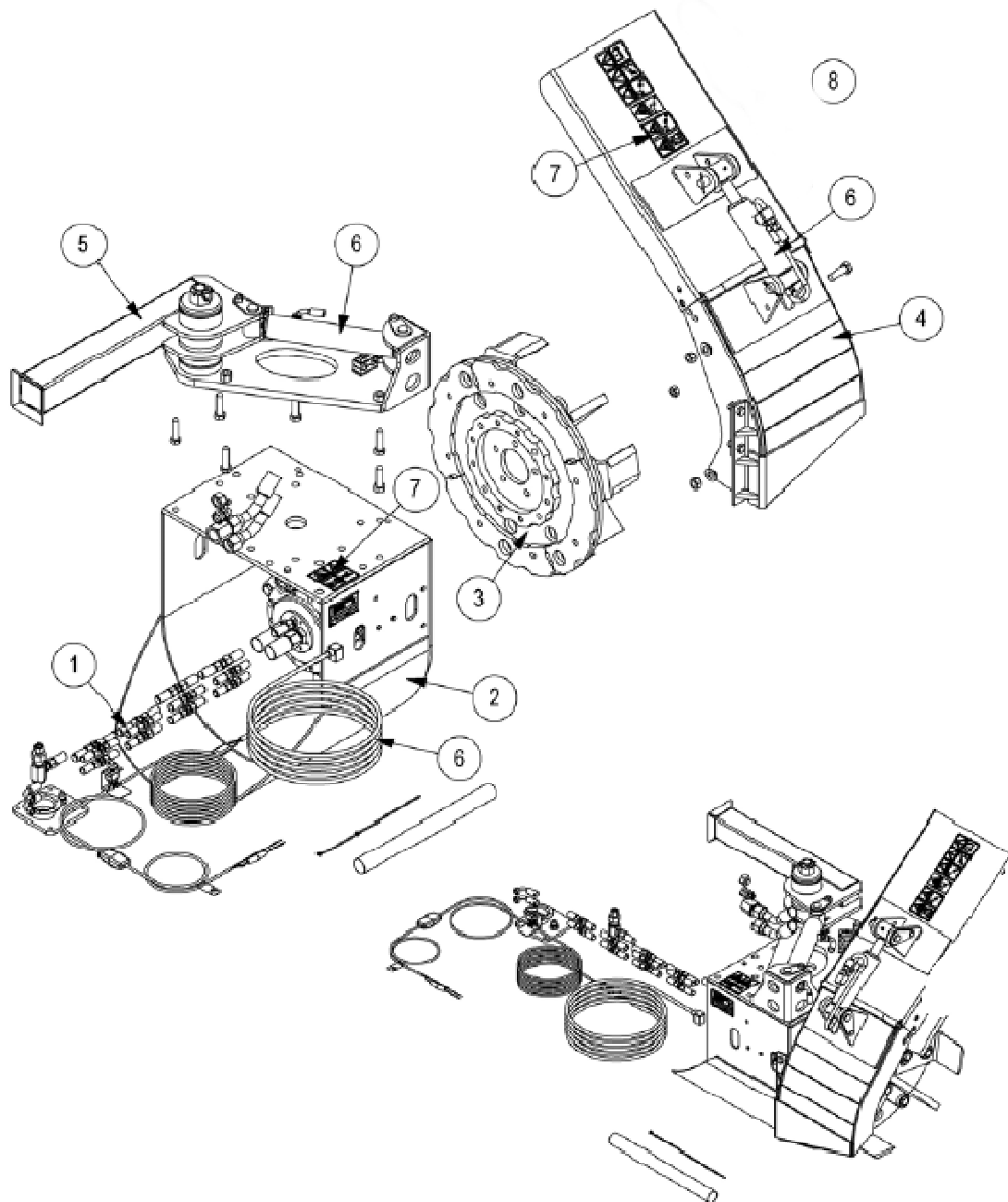

REF.	QTY.	PART No.	DESCRIPTION
		<b>6600944</b>	<b>ROTARY DITCHER ASSEMBLY - L/H build</b>
1	1	23067.02	HOSE KIT
2	1	6600702	MOTOR MODULE - HIGH SPEED
3	1	6600769	CUTTING DISC/BLADE ASSEMBLY
4	1	6600764	HYDRAULIC CHUTE LH (WIDE)
5	1	6600733	HYDRAULIC ROTATION MODULE LH
6	1	6600744	HYDRAULIC INSTALLATION MODULE
7	1	6600761	DECAL KIT - INSTRUCTIONS/WARNINGS
8	1	6600762	DECAL KIT

# Spearhead Rotary Ditch Cleaner

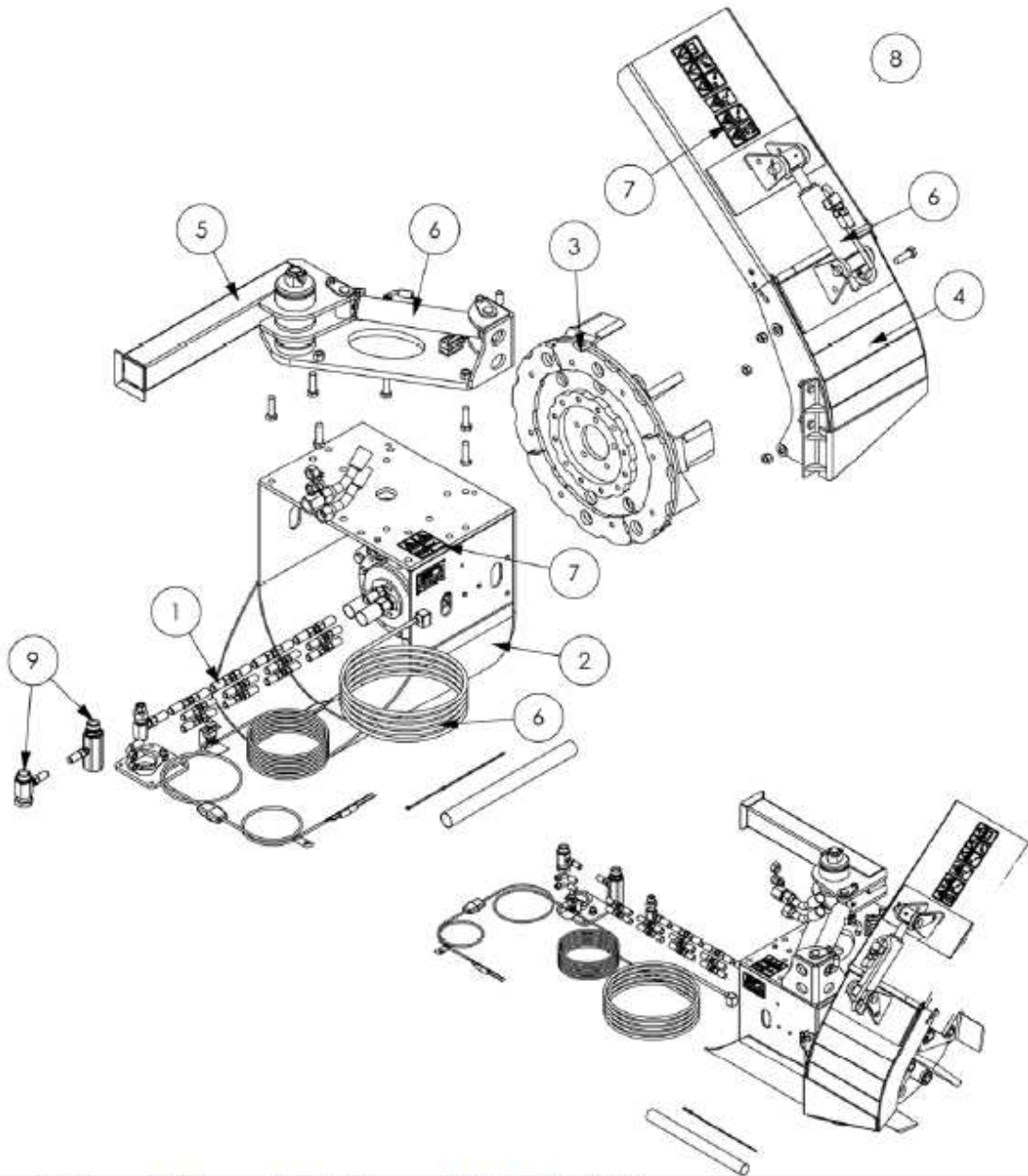

REF.	QTY.	PART No.	DESCRIPTION
		<b>6600945</b>	<b>ROTARY DITCHER ASSEMBLY - L/H build</b>
1	1	23067.02	HOSE KIT
2	1	6600702	MOTOR MODULE - HIGH SPEED
3	1	6600769	CUTTING DISC/BLADE ASSEMBLY
4	1	6600764	HYDRAULIC CHUTE LH (WIDE)
5	1	6600733	HYDRAULIC ROTATION MODULE LH
6	1	6600744	HYDRAULIC INSTALLATION MODULE
7	1	6600761	DECAL KIT - INSTRUCTIONS/WARNINGS
8	1	6600762	DECAL KIT
9	1	42949.01	BACK PRESSURE VALVE KIT



# Spearhead Rotary Ditch Cleaner

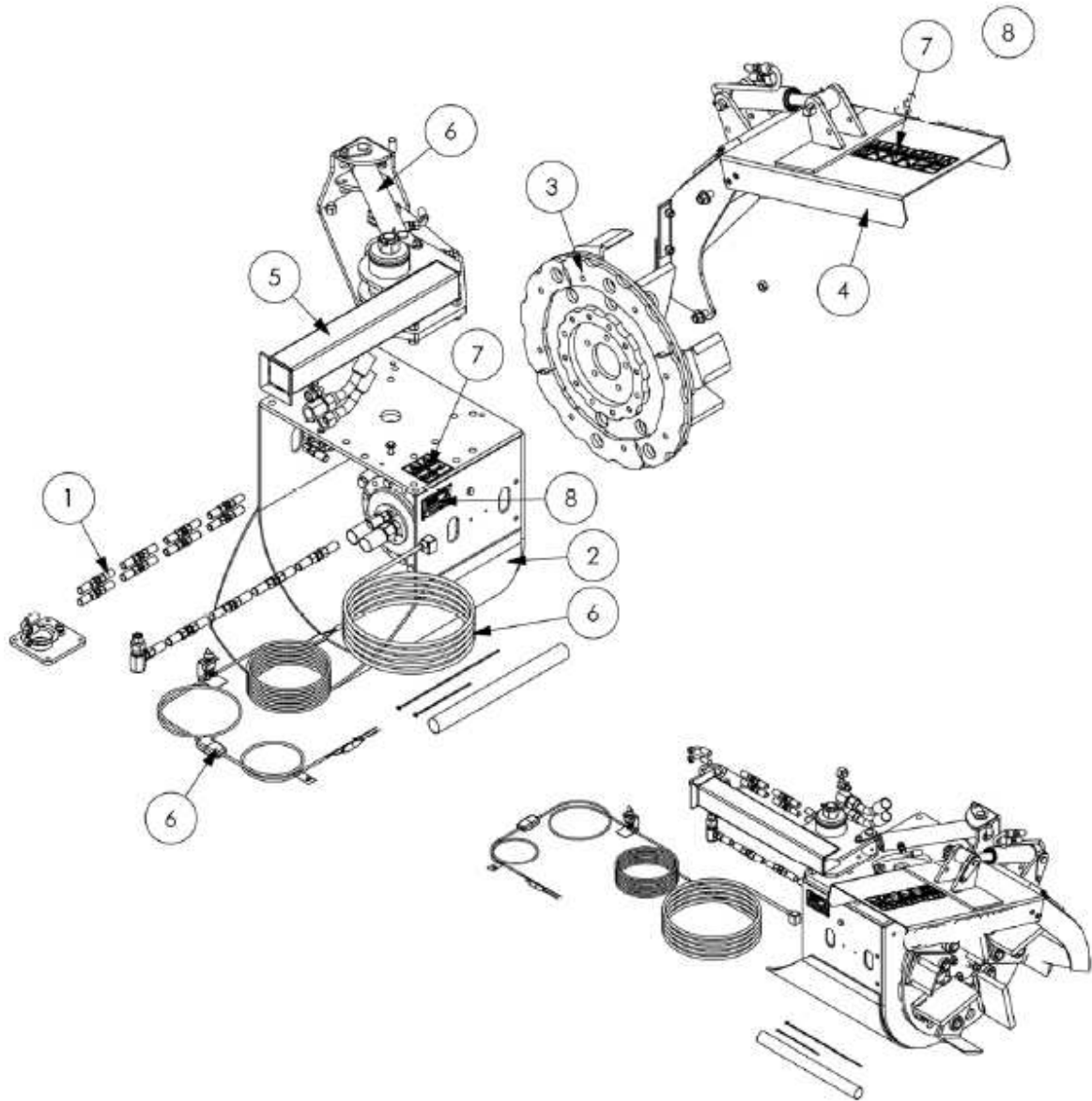

REF.	QTY.	PART No.	DESCRIPTION
		<b>6600946</b>	<b>ROTARY DITCHER ASSEMBLY - R/H build</b>
1	1	23067.02	HOSE KIT
2	1	6600702	MOTOR MODULE - HIGH SPEED
3	1	6600769	CUTTING DISC/BLADE ASSEMBLY
4	1	6600766	HYDRAULIC CHUTE RH (WIDE)
5	1	6600734	HYDRAULIC ROTATION MODULE RH
6	1	6600744	HYDRAULIC INSTALLATION MODULE
7	1	6600761	DECAL KIT - INSTRUCTIONS/WARNINGS
8	1	6600762	DECAL KIT

# Spearhead Rotary Ditch Cleaner

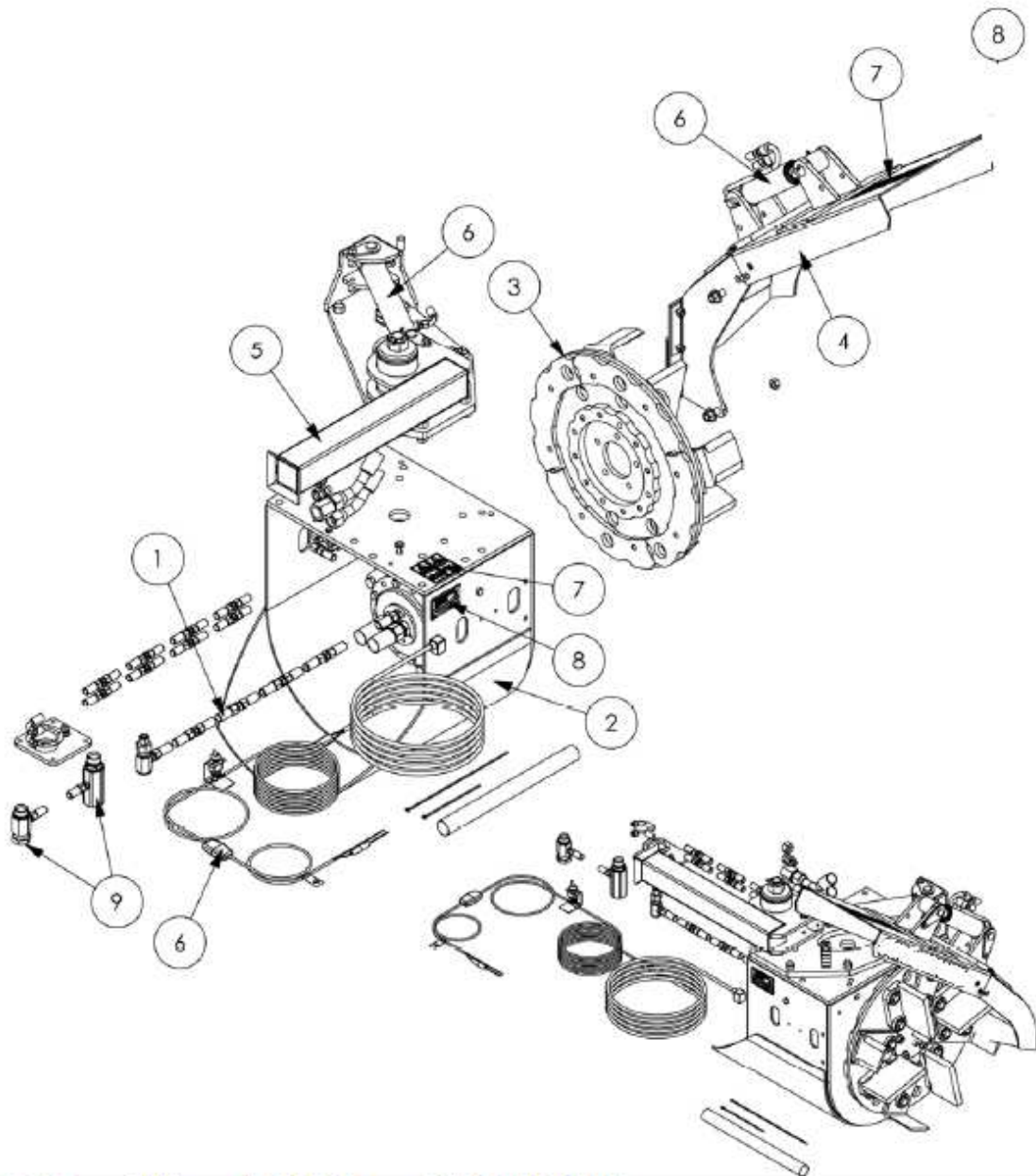

REF.	QTY.	PART No.	DESCRIPTION
		<b>6600947</b>	<b>ROTARY DITCHER ASSEMBLY - R/H build</b>
1	1	23067.02	HOSE KIT
2	1	6600702	MOTOR MODULE - HIGH SPEED
3	1	6600769	CUTTING DISC/BLADE ASSEMBLY
4	1	6600766	HYDRAULIC CHUTE RH (WIDE)
5	1	6600734	HYDRAULIC ROTATION MODULE RH
6	1	6600744	HYDRAULIC INSTALLATION MODULE
7	1	6600761	DECAL KIT - INSTRUCTIONS/WARNINGS
8	1	6600762	DECAL KIT
9	1	42949.01	BACK PRESSURE VALVE KIT

# Spearhead Rotary Ditch Cleaner

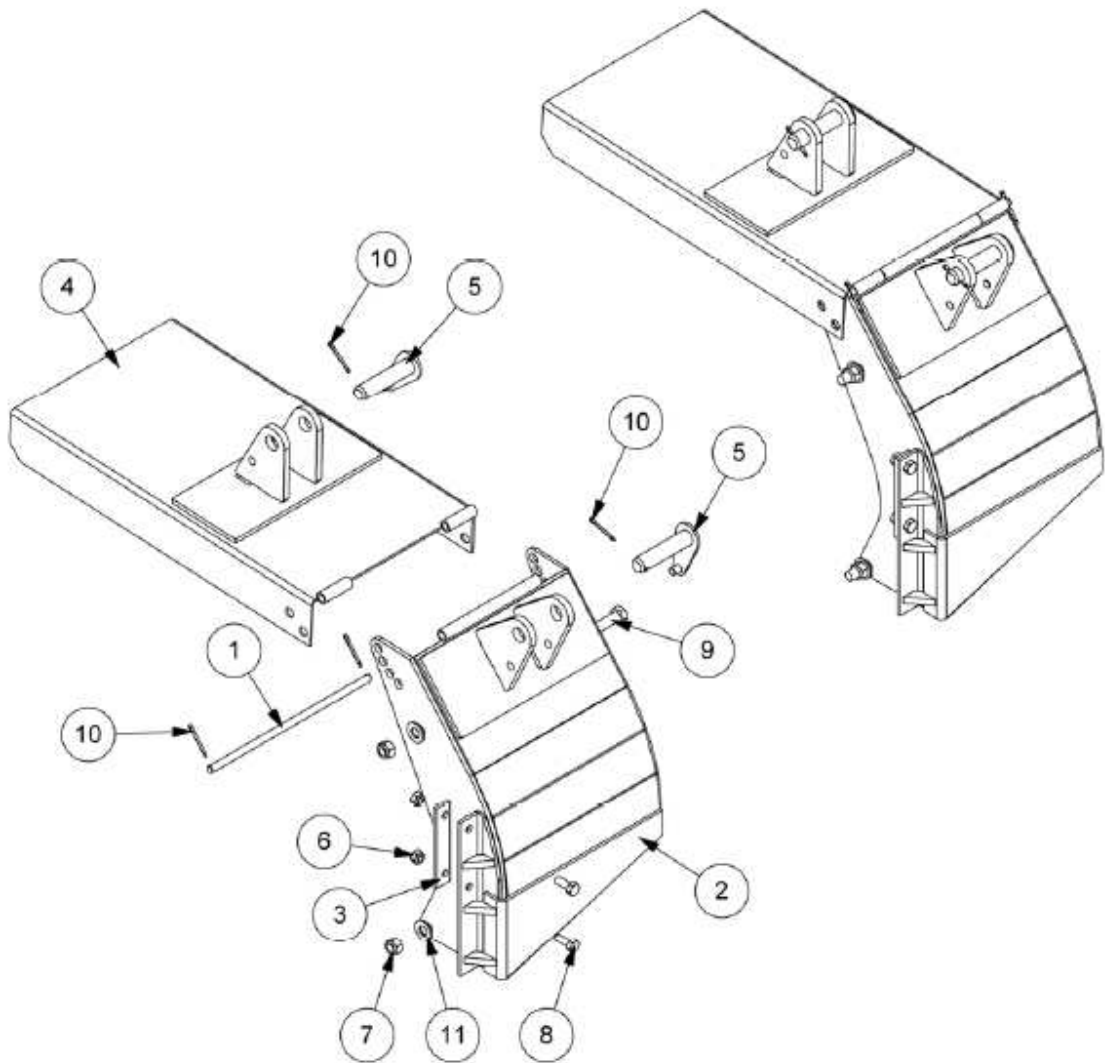

REF.	QTY.	PART No.	DESCRIPTION
		<b>6600764</b>	<b>HYDRAULIC CHUTE - L/H Build</b>
1	1	41.212.03	DEFLECTOR PIVOT PIN
2	1	41928.05	CHUTE (HYDRAULIC) LH
3	1	41928.40	SPACER
4	1	41929.04	DEFLECTOR (WIDE)
5	2	7192024	PIN
6	2	9163006	NYLOC NUT
7	2	9163007	NYLOC NUT
8	2	9313066	SETSCREW
9	2	9313107	SETSCREW
10	2	9501406	SPLIT PIN
11	2	0100106	FLAT WASHER

# Spearhead Rotary Ditch Cleaner

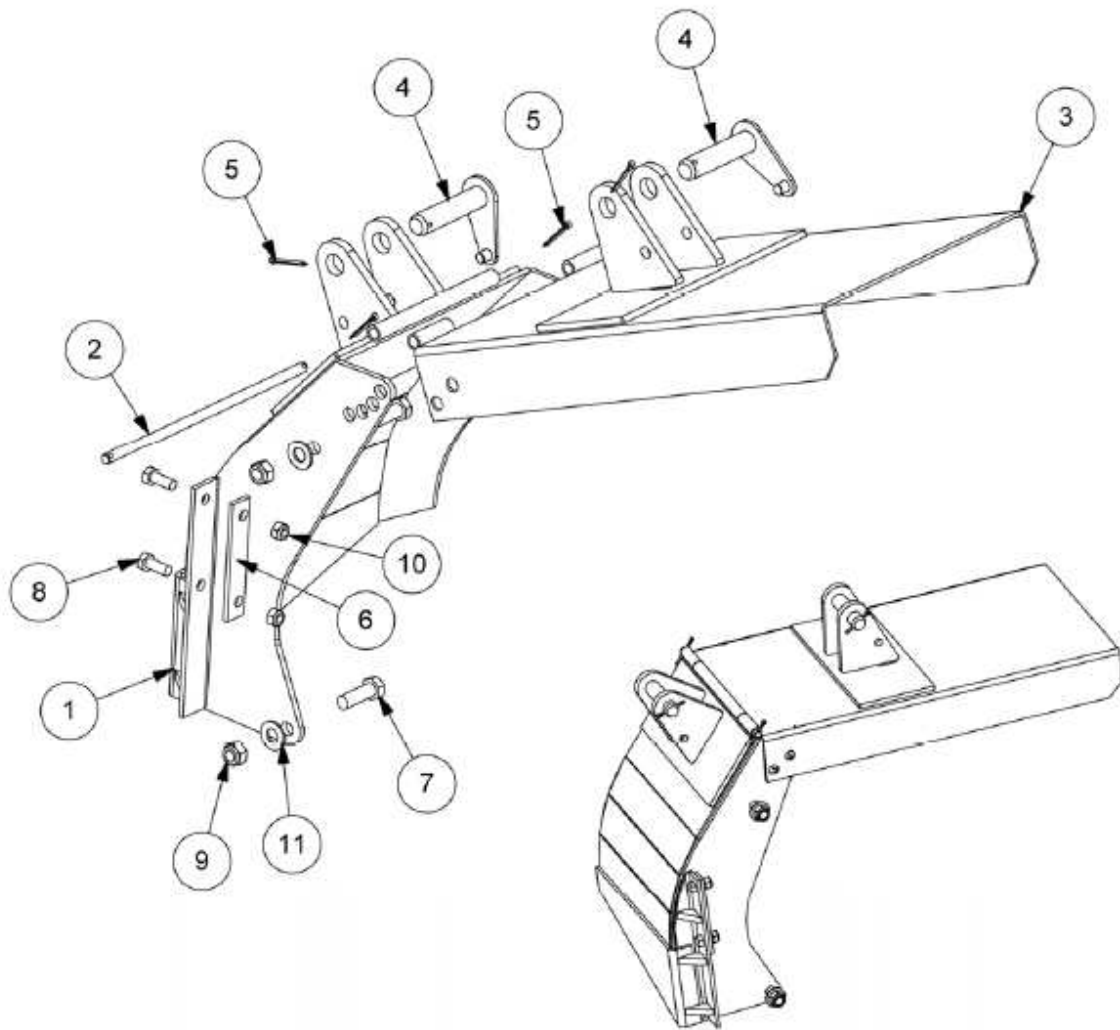

REF.	QTY.	PART No.	DESCRIPTION
		<b>6600766</b>	<b>HYDRAULIC CHUTE - R/H Build</b>
1	1	41928.06	CHUTE (HYDRAULIC) RH
2	1	41.212.03	DEFLECTOR PIVOT PIN
3	1	41929.04	DEFLECTOR (WIDE)
4	2	7192024	PIN
5	2	9501406	SPLIT PIN
6	1	41928.40	SPACER
7	2	9313107	SETSCREW
8	2	9313066	SETSCREW
9	2	9163007	NYLOC NUT
10	2	9163006	NYLOC NUT
11	2	0100106	FLAT WASHER



# Spearhead Rotary Ditch Cleaner

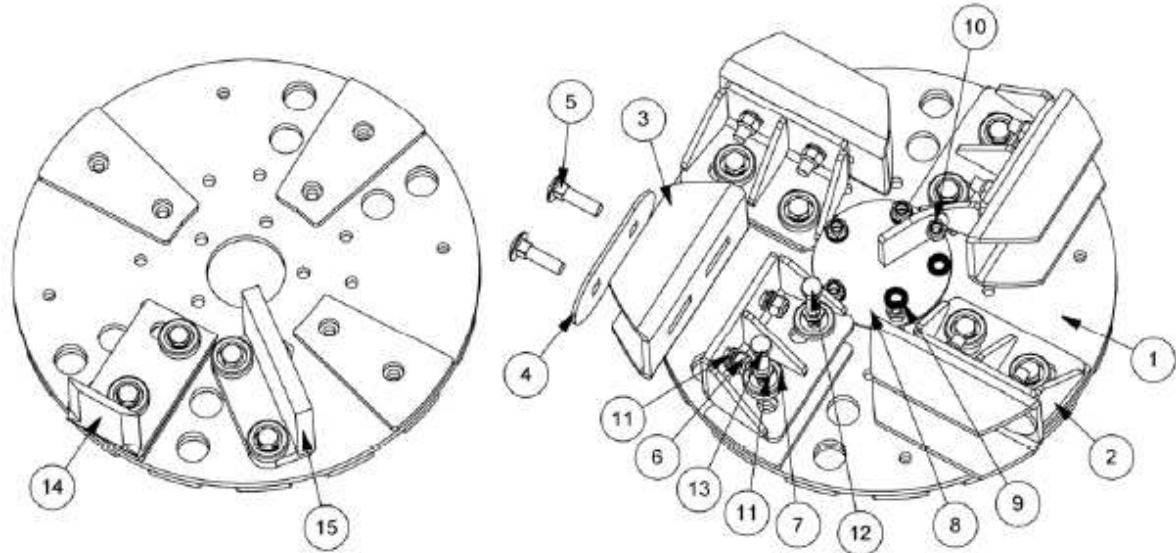

REF.	QTY.	PART No.	DESCRIPTION
		<b>6600769</b>	<b>CUTTING DISC / BLADE ASSEMBLY</b>
1	1	41.209.05	CUTTING DISC
2	4	41936.12	BLADE SUPPORT
3	4	41936.11	CUTTING BLADE
4	4	41936.10	BLADE CLAMP PLATE
5	8	9293127	COACH BOLT
6	8	9163007	NYLOC NUT
7	16	41.231.01	COLLAR
8	1	41.232.01	DEFLECTOR - CENTRE
9	5	B001015	NORDLOCK WASHERS
10	5	05.968.06	SELF LOCKING NUT (THIN)
11	24	9100507	LOCKING WASHER(PAIR)
12	8	0211186	UNF BOLT
13	8	0211166	UNF BOLT
14	4	41.216.04	CUTTING BLADE
15	4	41936.05	PADDEL

# Spearhead Rotary Ditch Cleaner

---



**Double Edged Blade  
(Part No. 41.216.01)**

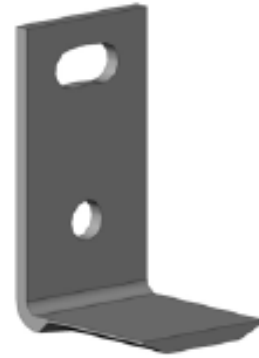

**Double Edged Blade  
(Part No. 41.216.04)**



**L/H Standard Duty Single Edged Blade  
(Part No. 41936.01)**

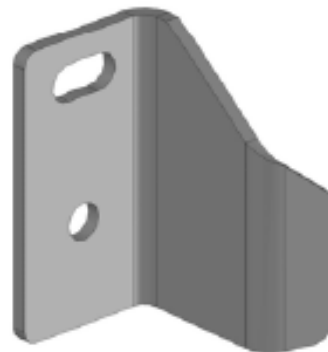

**R/H Standard Duty Single Edged Blade  
(Part No. 41936.02)**

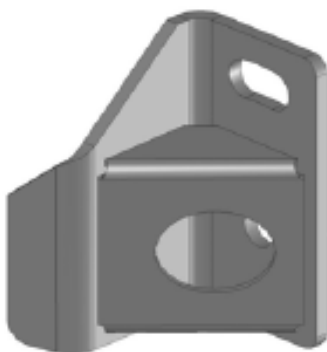

**L/H Heavy Duty Single Edged Blade  
(Part No. 41936.03)**

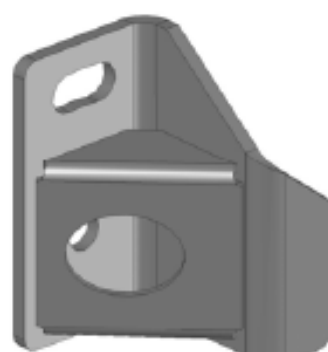

**R/H Heavy Duty Single Edged Blade  
(Part No. 41936.04)**

# Spearhead Rotary Ditch Cleaner

---

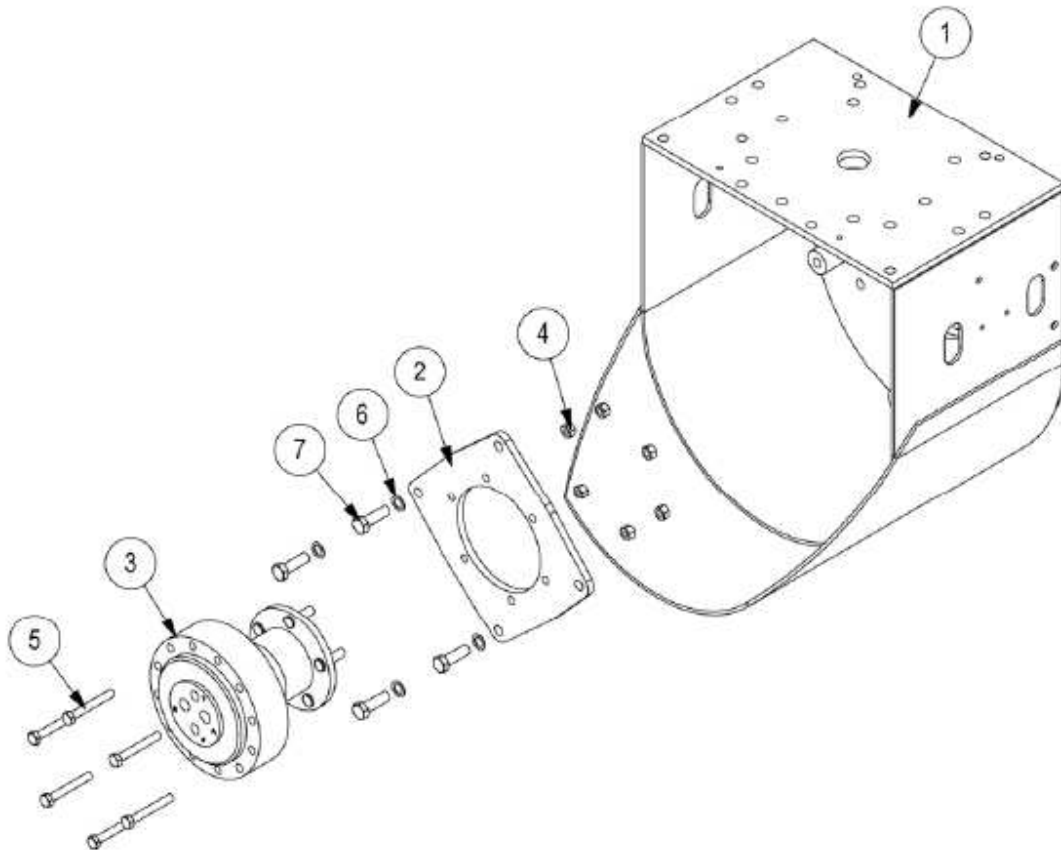

REF.	QTY.	PART No.	DESCRIPTION
		<b>6600702</b>	<b>MOTOR MODULE (HIGH SPEED)</b>
1	1	41.208.02	MAIN HOUSING
2	1	41927.02	ADAPTOR PLATE
3	1	8301298	MOTOR (200cc)
4	6	9163006	NYLOC NUT
5	6	9213186	BOLT
6	4	05.283.04	SHAKEPROOF WASHER
7	4	9313107	SETSCREW

# Spearhead Rotary Ditch Cleaner

---

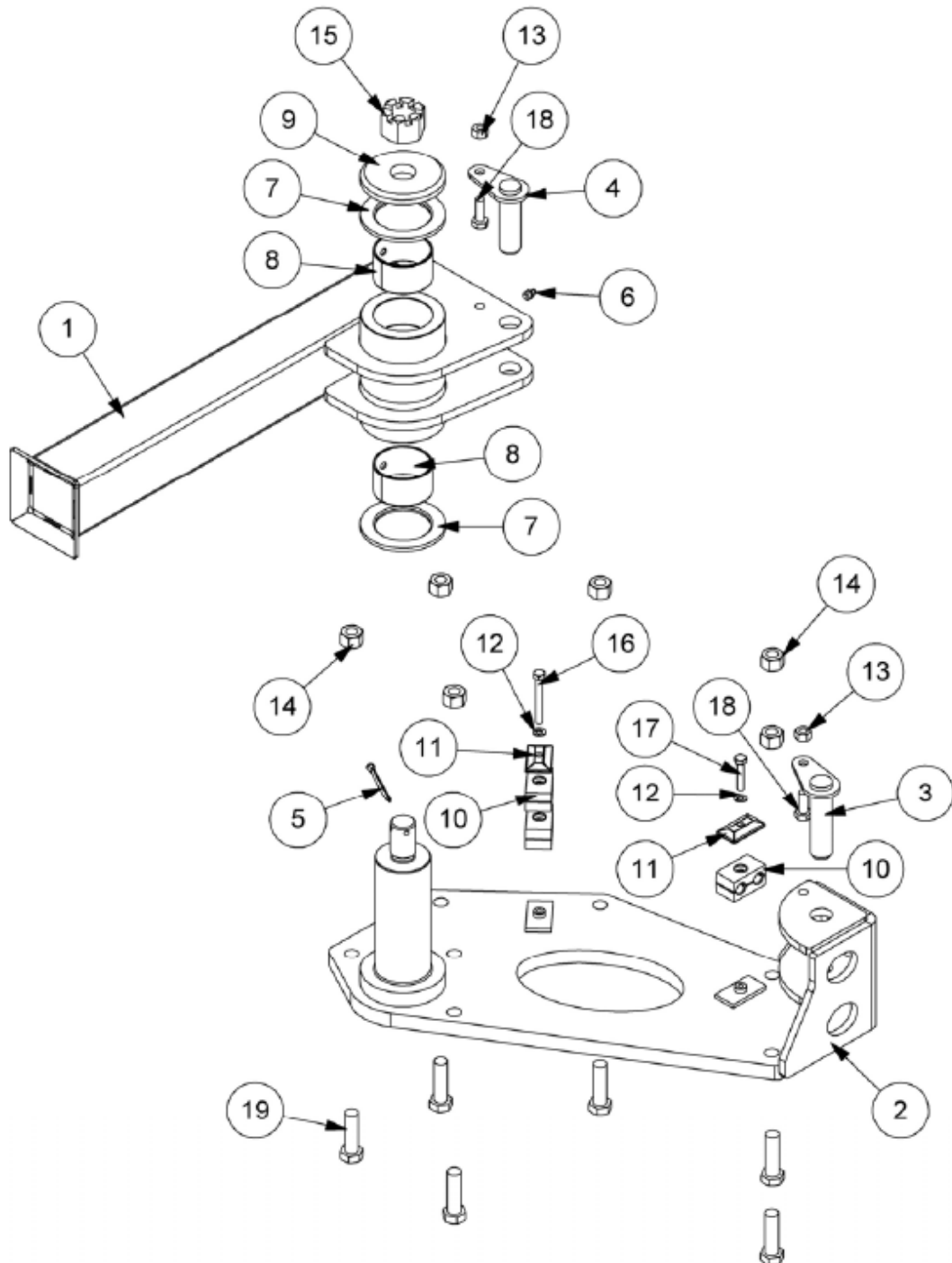



# Spearhead Rotary Ditch Cleaner

---

REF.	QTY.	PART No.	DESCRIPTION
		6600733	HYD. ROTATION MODULE - L/H Build
		6600734	HYD. ROTATION MODULE - R/H Build
1	1	22628.01	MOUNTING BRACKET
2	1	22629.01	ROTATOR BRACKET - L/H Build
	1	22629.02	ROTATOR BRACKET - R/H Build
3	1	41267.03	PIN
4	1	41691.06	PIN
5	1	05.284.27	SPLIT COTTER
6	1	0901121	GREASE NIPPLE
7	2	21135.02	THRUST WASHER
8	2	21649.02	GLACIER BUSH
9	1	22204.01	RETAINING WASHER
10	3	7193065	HOSE CLAMP (PAIR)
11	2	7193066	CLAMP PLATE
12	2	9100204	SPRING WASHER
13	2	9163005	NYLOC NUT
14	6	9163007	NYLOC NUT
15	1	9183010	SLOTTED NUT
16	1	9213134	BOLT
17	1	9213084	BOLT
18	2	9313065	SETSCREW
19	6	9313117	SETSCREW

# Spearhead Rotary Ditch Cleaner

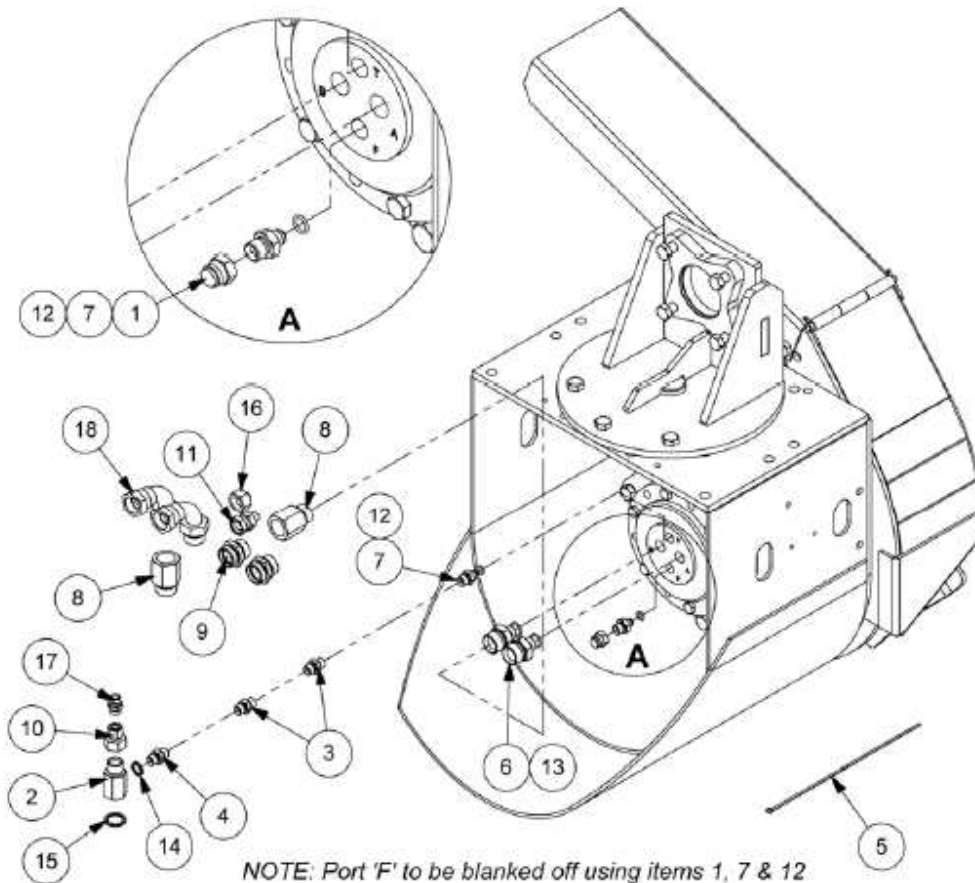

REF.	QTY.	PART No.	DESCRIPTION
		<b>6600746</b>	<b>HYDRAULIC INSTALLATION MODULE</b>
1	1	05.433.04	BLANKING CAP
2	1	41.217.01	ADAPTOR
3	2	05.124.01	ADAPTOR
4	1	6000113	ADAPTOR
5	10	7196045	HOSE TIE
6	2	8581331	ADAPTOR
7	2	08.955.06	ADAPTOR
8	2	8581241	EXTENSION ADAPTOR
9	2	8581387	ADAPTOR
10	1	8581432	SWIVEL ADAPTOR
11	1	8581544	SWIVEL ADAPTOR
12	2	8600906	O RING 906
13	2	8600910	O RING 910
14	1	8650103	BONDED SEAL
15	1	8650106	BONDED SEAL
16	1	G3812119	BLANKING CAP
17	1	G3812368	ADAPTOR
18	2	8581264	SWEPT ADAPTOR 90°

# Spearhead Rotary Ditch Cleaner

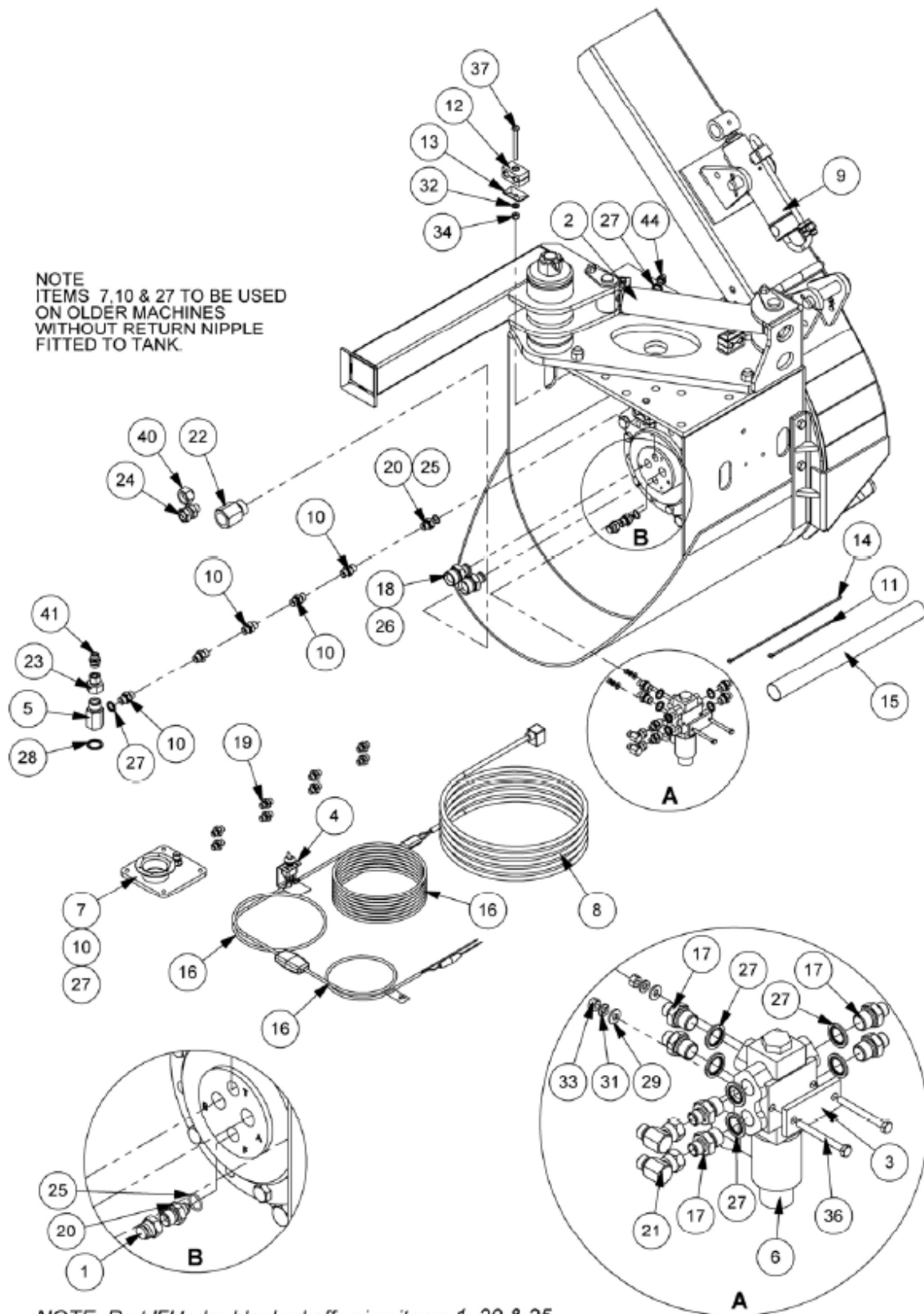

NOTE  
ITEMS 7, 10 & 27 TO BE USED  
ON OLDER MACHINES  
WITHOUT RETURN NIPPLE  
FITTED TO TANK.

NOTE: Port 'F' to be blanked off using items 1, 20 & 25

# Spearhead Rotary Ditch Cleaner

---

REF.	QTY.	PART No.	DESCRIPTION
		<b>6600744</b>	<b>HYDRAULIC INSTALLATION MODULE</b>
1	1	05.433.04	BLANKING CAP
2	1	7560355	HYDRAULIC RAM
3	1	21546.01	SPACER
4	1	21556.01	SWITCH BRACKET
5	1	41.217.01	ADAPTOR
6	1	41605.01	DIVERTER VALVE
7	1	43175.02	COVER PLATE
8	1	43177.43	LOOM - DIVERTER EXTENSION
9	1	43377.03	HYDRAULIC RAM
10	6	6000113	ADAPTOR
11	8	7135084	CABLE TIE
12	2	7193065	HOSE CLAMP (PAIR)
13	2	7193066	CLAMP PLATE
14	10	7196045	HOSE TIE
15	1	7213005	HOSE ARMOUR
16	1	8402208	SWITCH KIT
17	6	8581115	ADAPTOR
18	2	8581331	ADAPTOR
19	8	8581169	ADAPTOR
20	2	08.955.06	ADAPTOR
21	2	8581190	ADAPTOR ELBOW 90°
22	1	8581241	EXTENSION ADAPTOR
23	1	8581432	SWIVEL ADAPTOR
24	1	8581544	SWIVEL ADAPTOR
25	2	8600908	O RING
26	2	8600910	O RING
27	10	8650103	BONDED SEAL
28	1	8650106	BONDED SEAL
29	2	9100103	FLAT WASHER
30	1	9100105	FLAT WASHER
31	2	9100203	SPRING WASHER
32	2	9100204	SPRING WASHER
33	2	9163003	NYLOC NUT
34	2	9163004	NYLOC NUT
35	1	9163005	NYLOC NUT
36	2	9213123	BOLT
37	1	9213164	BOLT
38	1	9213124	BOLT
39	1	9213165	BOLT
40	1	G3812119	BLANKING CAP
41	1	G3812368	ADAPTOR
42	1	7193063	PIPE CLAMP(PAIR)
43	1	7193064	CLAMP PLATE
44	2	8130103	ADAPTOR RESTRICTOR

# Spearhead Rotary Ditch Cleaner

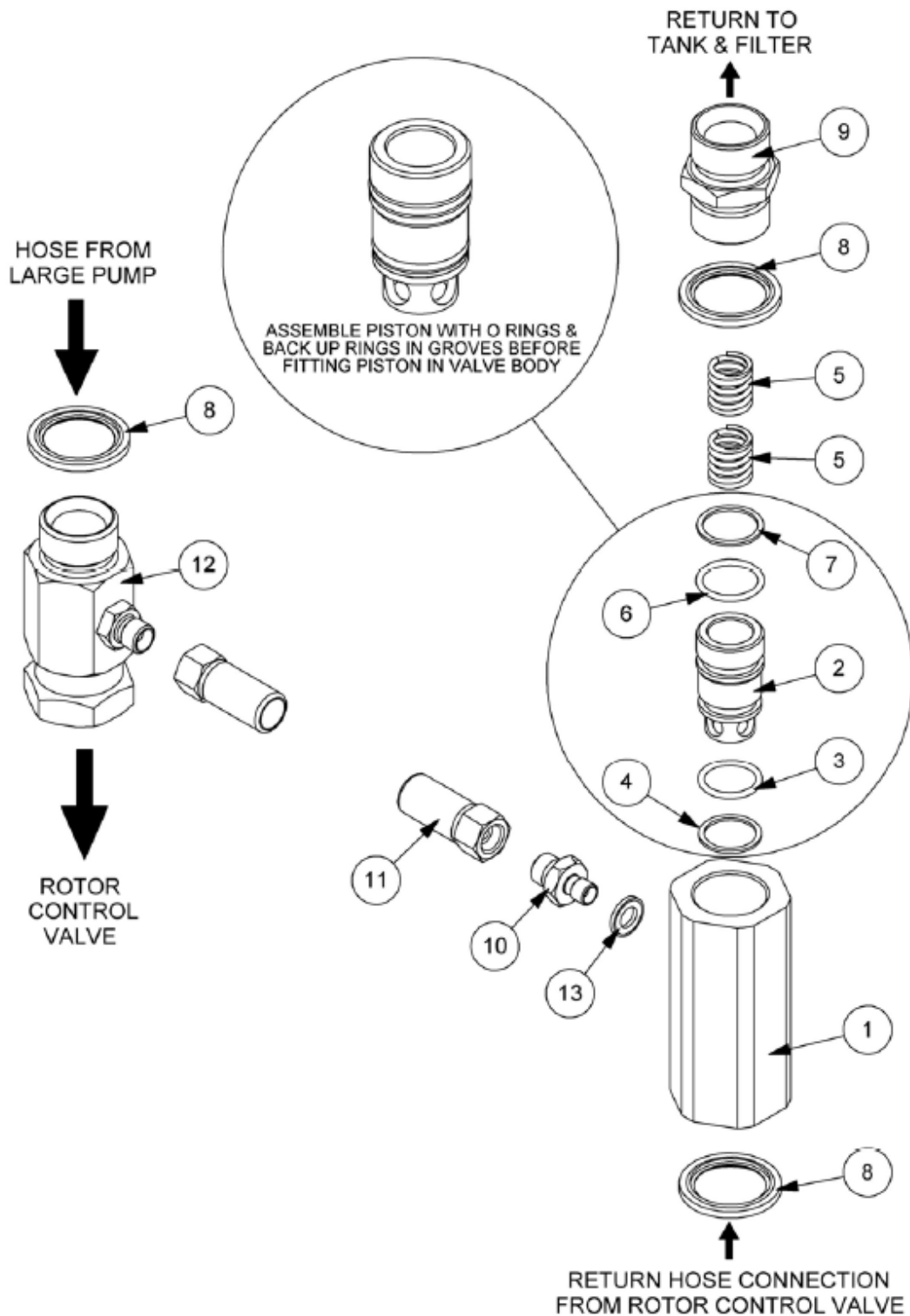

# Spearhead Rotary Ditch Cleaner

---

REF.	QTY.	PART No.	DESCRIPTION
		<b>42949.01</b>	<b>BACK PRESSURE VALVE KIT</b>
1	1	42949.31	VALVE BODY
2	1	42949.32	PISTON
3	1	8600402	O RING
4	1	8609402	AE RING
5	2	8106027	SPRING
6	1	8600403	O RING
7	1	8609403	AE RING
8	3	8650108	BONDED SEAL
9	1	42949.33	ADAPTOR
10	1	30.052.76	ADAPTOR
11	1	10.001.08	HOSE - 1/4" BSP FS/FS x 400mm
12	1	04.056.33	ADAPTOR TEE
13	1	05.290.01	BONDED SEAL

# Spearhead Rotary Ditch Cleaner

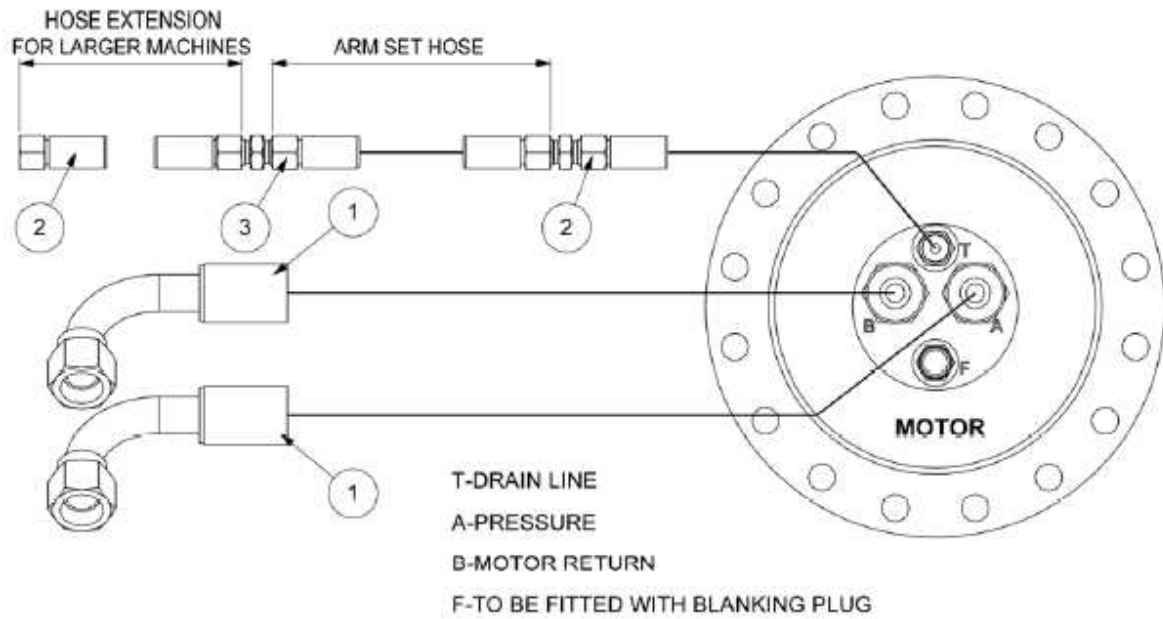

REF.	QTY.	PART No.	DESCRIPTION
		<b>23067.03</b>	<b>HYDRAULIC HOSE KIT</b>
1	2	21268.21	HOSE - 1"BSP FS/F90 x 1100mm
2	2	8511243	HOSE - 3/8"BSP FS/FS x 42"
3	1	8511433	HOSE - 3/8"BSP FS/FS x 300"



# Spearhead Rotary Ditch Cleaner

REF.	QTY.	PART No.	DESCRIPTION
		<b>23067.02</b>	<b>HYDRAULIC HOSE KIT</b>
1	2	21270.29	HOSE - 1" BSP F/S/F135 x 1900mm
2	1	10.003.70	HOSE - 3/8" BSP FS/FS x 6000mm
3	1	10.003.32	HOSE - 3/8" BSP FS/FS x 2200mm
4	3	10.003.20	HOSE - 3/8" BSP FS/FS x 1000mm
5	2	10.002.21	HOSE - 1/4" BSP FS/F90 x 1100mm
6	2	10.002.25	HOSE - 1/4" BSP FS/F90 x 1500mm
7	2	10.002.47	HOSE - 1/4" BSP FS/F90 x 3700mm
8	2	10.002.70	HOSE - 1/4" BSP FS/F90 x 6000mm
9	6	10.001.20	HOSE - 1/4" BSP FS/FS x 1000mm

T-DRAIN LINE  
 A-PRESSURE  
 B-MOTOR RETURN  
 F-TO BE FITTED WITH BLANKING PLUG

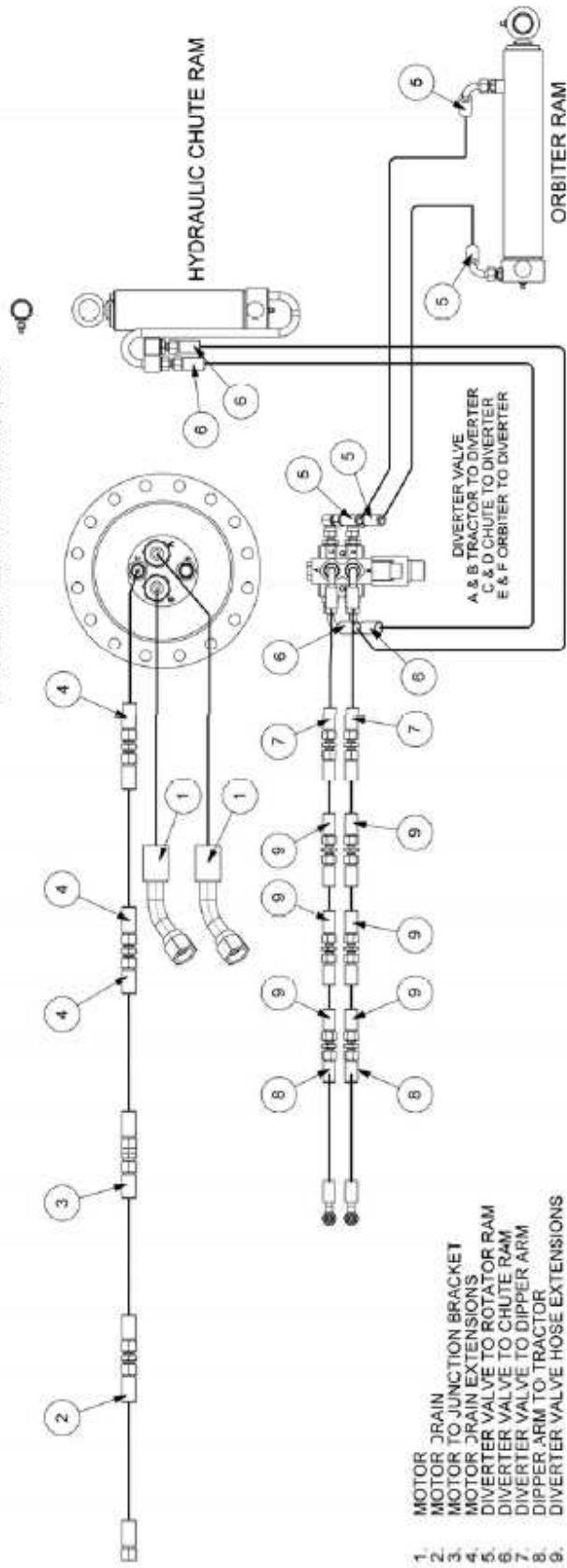

- 1. MOTOR DRAIN
- 2. MOTOR TO JUNCTION BRACKET
- 3. MOTOR DRAIN EXTENSIONS
- 4. DIVERTER VALVE TO ROTATOR RAM
- 5. DIVERTER VALVE TO CHUTE RAM
- 6. DIVERTER VALVE TO DIPPER ARM
- 7. DIPPER ARM TO TRACTOR
- 8. DIVERTER VALVE HOSE EXTENSIONS



# Spearhead Rotary Ditch Cleaner

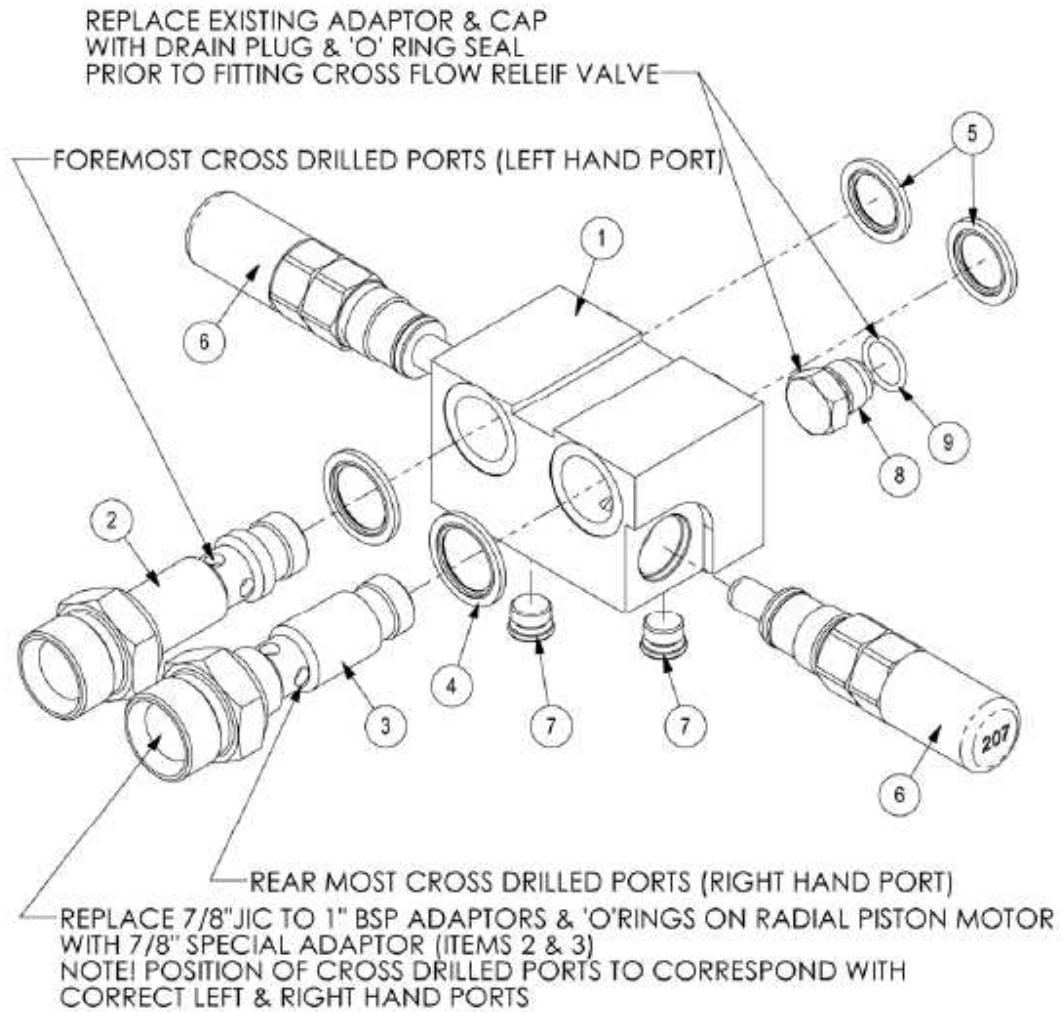

REF.	QTY.	PART No.	DESCRIPTION
		<b>6600765</b>	<b>RELIEF VALVE KIT</b>
1	1	8132331	RELIEF VALVE MANIFOLD
2	1	8581656	ADAPTOR CROSS DRILLED (BACK PORT)
3	1	8581657	ADAPTOR CROSS DRILLED (FRONT PORT)
4	2	8650106	BONDED SEAL
5	2	8650105	BONDED SEAL
6	2	8125095	RELIEF VALVE (207 BAR)
7	2	23242.05	ZERO LEAK PLUG
8	1	8581587	JIC SOLID PLUG
9	1	8600908	O RING



Spearhead Machinery Ltd  
Green View  
Salford Priors  
Evesham  
Worcestershire  
WR11 8SW

Tel: 01789 491860

Fax: 01789 778683

[www.spearheadmachinery.com](http://www.spearheadmachinery.com)  
[parts@spearheadmachinery.com](mailto:parts@spearheadmachinery.com)