

SPEARHEAD

PROJECT BLACK FLAIL HEAD 1.2/1.6M

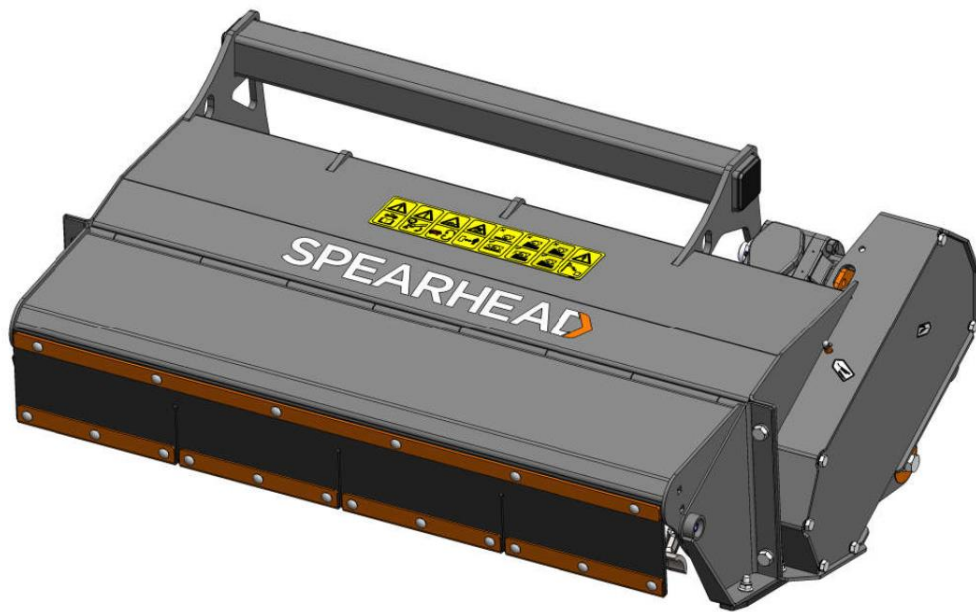

Edition 2.0 – December 2020
Part No. 8999074

HANDBOOK

IMPORTANT VERIFICATION OF WARRANTY REGISTRATION



DEALER WARRANTY INFORMATION & REGISTRATION VERIFICATION

It is imperative that the selling dealer registers this machine with Spearhead Machinery Limited before delivery to the end user – failure to do so may affect the validity of the machine warranty.

To register machines go to the Spearhead Machinery Limited web site at www.spearheadmachinery.com, log onto 'Dealer Inside' and select the 'Machine Registration button' which can be found in the Service Section of the site. Confirm to the customer that the machine has been registered in the section below.

Should you experience any problems registering a machine in this manner please contact the Spearhead Service Department on 01789 491867.

Registration Verification

Dealer Name:
Dealer Address:
Customer Name:
Date of Warranty Registration:/...../..... Dealer Signature:

NOTE TO CUSTOMER / OWNER

Please ensure that the above section has been completed and signed by the selling dealer to verify that your machine has been registered with Spearhead Machinery Limited.

IMPORTANT: During the initial 'bedding in' period of a new machine it is the customer's responsibility to regularly inspect all nuts, bolts and hose connections for tightness and re-tighten if required. New hydraulic connections occasionally weep small amounts of oil as the seals and joints settle in – where this occurs it can be cured by re-tightening the connection – refer to torque settings chart below. The tasks stated above should be performed on an hourly basis during the first day of work and at least daily thereafter as part of the machines general maintenance procedure.

PROJECT BLACK FLAIL HEAD

CAUTION: DO NOT OVER TORQUE HYDRAULIC FITTINGS AND HOSES

TORQUE SETTINGS FOR HYDRAULIC FITTINGS

HYDRAULIC HOSE ENDS		
BSP	Setting	Metric
1/4"	18 Nm	19 mm
3/8"	31 Nm	22 mm
1/2"	49 Nm	27 mm
5/8"	60 Nm	30 mm
3/4"	80 Nm	32 mm
1"	125 Nm	41 mm
1.1/4"	190 Nm	50 mm
1.1/2"	250 Nm	55 mm
2"	420 Nm	70 mm

PORT ADAPTORS WITH BONDED SEALS		
BSP	Setting	Metric
1/4"	34 Nm	19 mm
3/8"	47 Nm	22 mm
1/2"	102 Nm	27 mm
5/8"	122 Nm	30 mm
3/4"	149 Nm	32 mm
1"	203 Nm	41 mm
1.1/4"	305 Nm	50 mm
1.1/2"	305 Nm	55 mm
2"	400 Nm	70 mm

PROJECT BLACK FLAIL HEAD

Contents

General Information

Introduction.....	5
-------------------	---

Safety

Machine Safety Sticker.....	6
Safety Recommendation.....	7
High Voltage Cables.....	9

Installing/Removing Machine

Attaching your Head.....	11
Running Up your Head.....	13

Set-up

Cutting Head Set-up.....	14
Hedge Cutting.....	15
Grass Cutting.....	16

Operation

Operation Warnings.....	17
Engaging Head Drive.....	18
Disengage Head Drive.....	18
Tractor Forward Speed.....	19
Cutting Sequence.....	19
Wire Trap.....	20
Hydraulic Rear Roller.....	21
Hydraulic Front Hood.....	22

Service & Maintenance

Greasing/Lubrication.....	23
Hydraulic Hoses.....	24
Routine Checks.....	25
Storage.....	26
Torque Settings.....	27
Regular Service Chart.....	27

Diagnostics

Trouble Shooting.....	28
Pump & Motor Failure.....	29

PROJECT BLACK FLAIL HEAD

PROJECT BLACK FLAIL HEAD

Introduction

Flail Head range:

- Suitable for contractors requiring high output.
 - 1.2/1.6M

A range of very robust high capacity flail heads to suit many applications that are easy to operate and maintain. To ensure trouble-free operation this manual should be carefully studied.

The term Left and Right hand applies to the machine when coupled to the tractor and viewed from the rear, this also applies to the tractor.

Important Note

The information contained in this manual is correct at the time of publication. However, in the course of constant development, changes in specification are inevitable. Should you find the information given in this book different to the Machine it relates to please contact the "After Sales Department" for advice.

Please ensure that this manual is handed to the operator before using the machine for the first time. The operator must fully understand the contents of this manual before using this machine. (If the machine is resold the Manual must be given to the new

PROJECT BLACK FLAIL HEAD

Machine Safety Decal



Image key, from left to right:

1. Remove key before working on machine.
2. Keep bolts tight, check every 8 hours.
3. Keep a safe distance from cutting blades.
4. Keep a safe distance from thrown objects.
5. Use front hood down, rear roller down and flails cutting upwards when verge mowing.
6. Use front hood, rear roller up and flails cutting upwards when hedge cutting.
7. use rear roller up and only remove front hood when cutting downwards.
8. Keep a safe distance from overhead powerlines.

PROJECT BLACK FLAIL HEAD

Safety Recommendations

Beware of the following Potential Dangers associated with the use of this machine:

- Becoming trapped when hitching or unhitching.
- Tractor overbalancing when arm is extended.
- Electrocution due to hitting overhead power lines.
- Getting caught on rotating power take off (PTO).
- Being hit or caught by any moving part, e.g. belts, pulleys, arms, cutting head.
- Being hit by flying debris or machine parts due to machine damage.
- Machine overbalancing when not in use.
- Injection of high pressure oil from damaged couplings or hydraulic hoses.
- Accidents due to collision with other machines, or debris left on road.

Always

- Ensure the operator has read this handbook and has been trained to use the machine.
- Ensure all cab safety guards are in place and all tractor windows closed.
- Before leaving the tractor cab always ensure that the flail head is firmly on the ground, no weight is on the machine's hydraulics and the rotor has stopped spinning.
- Check that all guards are properly fitted and there are no damaged or loose parts. Particular attention should be given to the flails to ensure they are not damaged, cracked or missing.
- Inspect work area for wire, steel posts, large stones and other dangerous materials and remove before starting work.
- Beware of the danger of overhead power cables. The operator must be aware of the maximum height and reach of the machine when working under power cables. The minimum legal height for 11,000 and 22,000-volt cables is 5.2 metres from the ground. When fully extended, the machine may well exceed this height so extreme caution should be practised. For more information see **Overhead Powerlines** Section or contact the Health and Safety Executive or your local power company.
- Ensure that all warning labels are always visible and that they are not damaged, defaced or missing..
- Lower the head to the ground when parking up.
- Fit locking pins to slew and height before transport and before unhitching when applicable.
- Wear ear defenders if operating without a quiet cab or with the cab windows open.
- Ensure tractor guards are fitted correctly and are undamaged.
- Work at a safe speed, taking into account terrain, passing vehicles and obstacles.
- Ensure that the tractor meets the minimum weight recommendations of the machine manufacturer and that ballast is used if necessary.
- Check that machine fittings and couplings are in good condition.
- Follow the manufacturer's instructions for attachment and removal of machine from the tractor.

PROJECT BLACK FLAIL HEAD

- Use clear warning signs to alert others to the type of machine working in the vicinity. Signs should be placed at both ends of the work site and should be in accordance with Department of Transport recommendations.
- Ensure flails are of the type recommended by the manufacturer, are securely fitted and are undamaged.
- Ensure hydraulic pipes are correctly routed to avoid damage from chafing, stretching, pinching or kinking.
- Disengage the machine, stop the engine and remove the key before leaving the tractor cab for any reason.
- Clean up any debris left at the work site.
- Ensure that when you remove the machine from the tractor it is secured in a safe position using the stands provided.

Never

- Never operate the machine with other people present, as it is possible for debris, including stones, to be discharged from the front and rear of the flail head.
- Never operate the machine until you have read and understood the relevant Handbook and are familiar with the controls.
- Never use a machine that is poorly maintained or has guards that are damaged or missing.
- Never allow an inexperienced person to operate the machine without supervision.
- Never use or fit a machine onto a tractor if it doesn't meet the manufacturer's specification.
- Never use a machine if the hydraulic system shows signs of damage.
- Never attempt to detect a hydraulic leak with your hand, use a piece of card.
- Never allow children to play on or around the machine at any time.
- Never attempt any maintenance or adjustment without first disengaging the PTO, lowering the head to the ground, stopping the tractor engine and applying the tractor parking brake.
- Never leave the cab without removing the ignition key.
- Never operate the tractor or any controls from any position other than from the driving seat.
- Never stop the engine with the PTO engaged.
- Never operate with flails missing.
- Never operate PTO **above** recommended speed, 540 R.P.M.
- Never operate with wire around the rotor. Stop immediately.
- Never use the head at an angle, which may throw debris towards the cab.
- Never attempt to use the machine for any purpose other than that it was designed for.
- Never transport with the PTO engaged.
- Never enter the working area of the machine (risk of injury!).
- Never transport with the controls live, always turn off electrical isolator switch (red) and disconnect supply.

PROJECT BLACK FLAIL HEAD

Overhead Power Lines

It cannot be stressed enough the dangers involved when working in the vicinity of Overhead Power Lines (OHPLs). Some of our machines are capable of reach in excess of 8 metres (26'); they have the potential to well exceed, by possibly 3 metres (9' 9"), the lowest legal minimum height of 5.2 metres from the ground for 11,000 and 33,000 volt power lines.

Remember electrocution can occur without actually coming into contact with a power line as electricity can 'flashover' when machinery gets close to it.



WARNING: All operators must read the following information and be aware of the risks and dangers involved when working in the vicinity of Overhead Power Lines (OHPLs).

Wherever possible the safest option is always to avoid working in areas close to OHPLs.

Where unavoidable, all operators must perform a risk assessment and implement a safe procedure and system of work – see following page for details.

All operators should perform a risk assessment before operating the machine within 10m horizontal distance of any OHPLs.

Minimum Heights for Overhead Power Lines

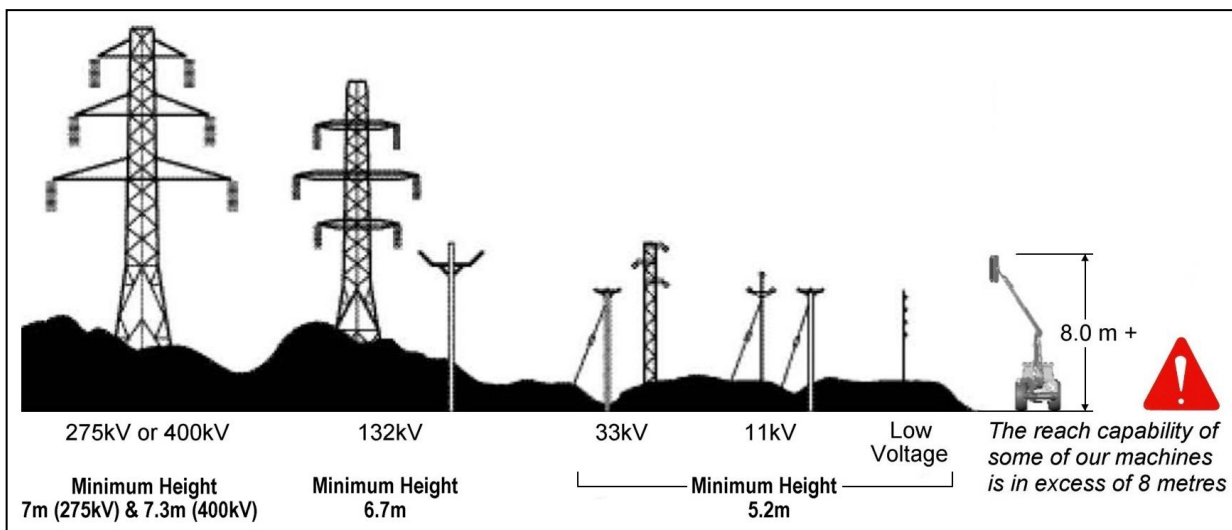

Absolute Minimum Exclusion Zones for Specific Overhead Power Lines

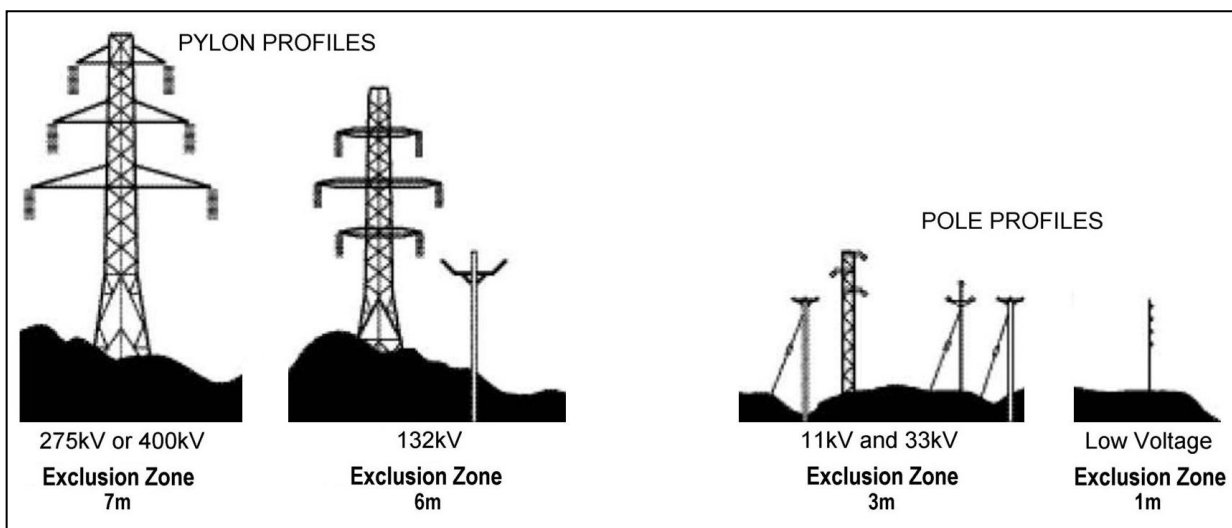

PROJECT BLACK FLAIL HEAD

Definitions of Exclusion Zones

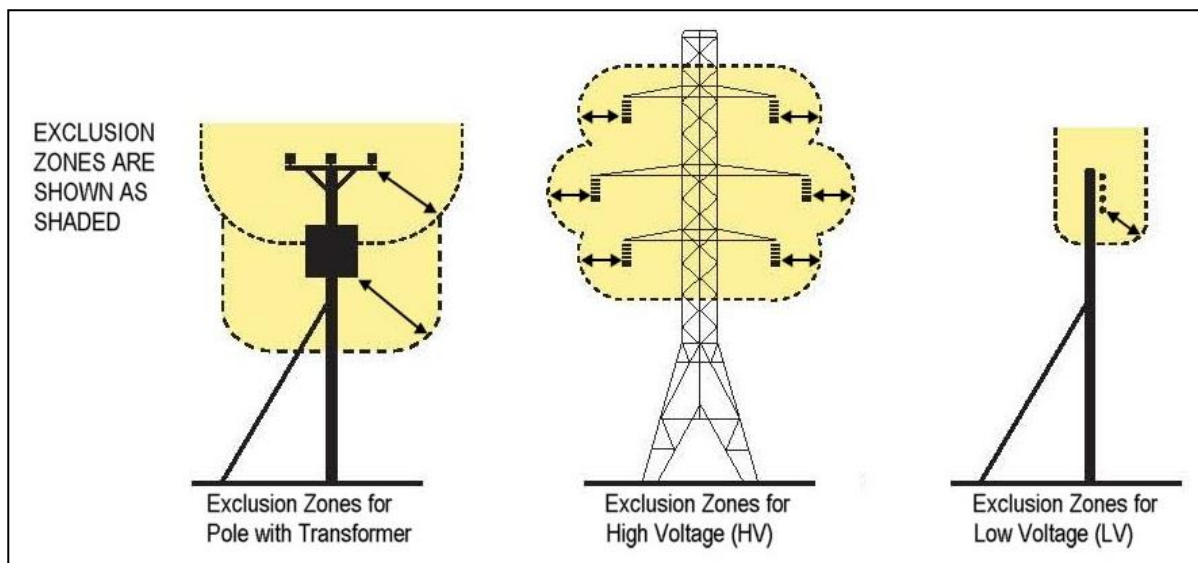

Risk Assessment

Before starting to work near OHPLs you should always assess the risks. The following points should be observed;

Know the risks of contacting OHPLs and the risk of flashover.

Find out the maximum height and maximum vertical reach of your machine.

Find out the location and route of all Power Lines within the work area.

Find out the operating voltage of all Power Lines within the work area.

Contact the local Distribution Network Operator (DNO) who will be able to advise you on the operating voltage, safe minimum clearance distance for working and additional precautions required.

Never attempt operate the machine in an exclusion zones.

Always work with extreme caution and plan your work ahead to avoid high risk areas.

If doubt exists do not work in the area – never risk the safety of yourself or others.

Emergency Action for Accidents Involving Electricity

- Never touch an overhead line - even if it has been brought down by machinery, or has fallen. Never assume lines are dead.
- When a machine is in contact with an overhead line, electrocution is possible if anyone touches both the machine and the ground. Stay in the machine and lower any raised parts in contact or drive the machine out of the lines if you can.
- If you need to get out to summon help or because of fire, jump out as far as you can without touching any wires or the machine - keep upright and away.
- Get the electricity company to disconnect the supply. Even if the line appears dead, do not touch it - automatic switching may reconnect the power.

Further information and leaflets on this and other agricultural safety subjects are available on the 'Health & Safety Executive' website at the following address: www.hse.gov.uk/pubns/agindex.htm

PROJECT BLACK FLAIL HEAD

Attaching Your Head To The Machine

Assuming you have followed the instructions in the operators manual you will have mounted the machine to the tractor rear linkage, connected the PTO and an electrical supply, now the machine arms can be operated from the tractor seat.



Warning

Take care when removing/connecting hydraulic fittings as they may contain high pressure oil!

1. Place the flail head along the tractor nearside wheel in the work position, about 1 metre away. Use a hydraulic jack and support stands to level the head if required.
2. Start the tractor and select 540 PTO.
3. Switch on machine electrics via the control panel.
4. Operate the joystick lever and slew switch to place the boom fully forward into the work position about ½ metre off the ground and 1 metre away from the tractor wheel. Use the controls move the boom to enable the head to be attached.



5. Disengage the PTO, switch off the electrics, turn off the tractor and remove the key before leaving the cab.
6. Attach the flail head to the boom using clamps and bolts supplied, we would recommend centre mounting at this point.
7. Ensure all connections are clean and free of any contamination before removing any blanking plugs.
8. Identify the pressure hose on the boom and the pressure port of motor (nearest anti-cav valve) also the returns hose and returns port. Using the hoses supplied make the correct connections as identified previously, the small hose is for the motor case drain this is returned separately to top of tank.

PROJECT BLACK FLAIL HEAD

9. Raise boom to lift the flail head clear of the ground before making a test run at low PTO speed, run for 5 minutes, stop and recheck all connections for oil leaks.
10. Restart machine, allow oil to warm before running at full speed too ensure smooth running without any vibration (do not exceed 540 R.P.M.).



Warning

It is most important the operator fully understands the procedure for attaching/un-attaching the flail head to/from the reach mower. The following text must be fully understood before attempting to attach the head. If there is any doubt please contact your supplying dealer or Spearhead Service Department. Failure to follow the correct procedure

To attach/unattached the head could result in personal injury or machine damage. Any resulting damage to a machine is not covered by warranty.

Always be sure to select a level firm surface, such as concrete before attaching.

When operating the tractor or machine's controls do so only when seated in the tractor cab. Do not allow anyone to stand on or amongst linkage for any reason.



Operate the main arm to bring the frame horizontal by lowering the head weight to the ground.

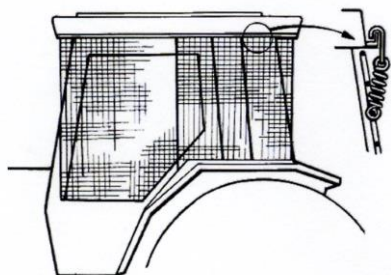

Use only tractors with safety glass. If windows are not laminated safety glass, polycarbonate glazing must be fitted between operator and cab meshing. Shape mesh to cover all windows that the driver will look through to view flail head in any operating position. Mesh can be retained by springs and clips supplied, but it is the operators responsibility to ensure guarding is firmly in place.

PROJECT BLACK FLAIL HEAD

Running Up Your Machine

1. First ensure the rotor is in the 'off' position and PTO drive is disengaged, then start the tractor.
2. Engage PTO into gear and run machine up to low revs, allowing oil to circulate for about 15 minutes before operating arms.
3. Re-check oil level, - check for oil leaks. All Spearhead machines have been run-up and checked thoroughly. However, hose connections can become loose in transit and these should be checked again before the machine is put to work.
4. Operate the arms through the full amount of travel; check all movements are functioning correctly.
5. Place flail head near ground in a safe position and with tractor engine revs low, select 'start' position for the flail motor.
6. Once the rotor is settled, slowly increase speed of PTO to 540 R.P.M. and run for a further 5 minutes. Slowly reduce speed and then disengage PTO.
7. Check all hoses for kinks, pinching, chafing and leaks.
8. Re-check oil level.



Warning

The rotor will take a long time to stop. Never leave the cab until PTO is disengaged, engine stopped and rotor has stopped spinning.

PROJECT BLACK FLAIL HEAD

Cutting Head Set-Up

Cutting Width

Standard 1.2m is suitable for both grass and hedges and optimises power to weight ratio.

Optional 1.6m is best used for hedge trimming to reduce the number of passes. However, there is less power per flail, and an increased weight penalty, which is not recommended on long reach machines and especially not for grass cutting.



Warning

Never attempt to operate the machine without the rear roller correctly fitted. The roller performs a key safety function should the rotor shaft pick up wire. It is essential for operator safety that it remains in place. It is also an essential structural part of the cutting head. Removing it will cause premature wear on rotor bearings and will lead to fatigue on the fabrications.

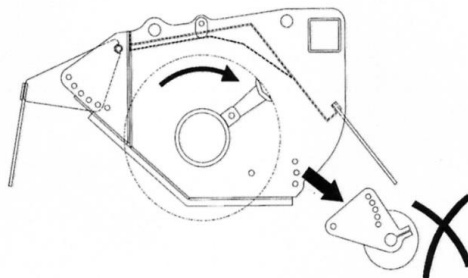

PROJECT BLACK FLAIL HEAD

Hedge Cutting

Recommended for hedge cutting

- 1.2m or 1.6m rotor
- T" flails or "Boot" flails
- Rear flap
- Front flap

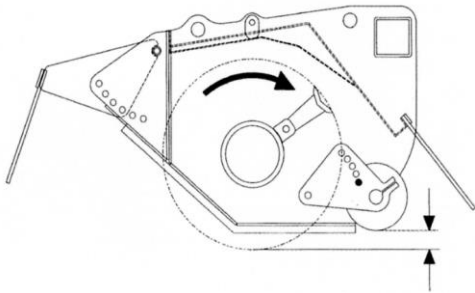

Roller Set-Up

The roller should be raised so that it is clear of the top of the hedge. The adjustable front guard should be set as low as possible without restricting the ability of the hedge to enter the cutting head.

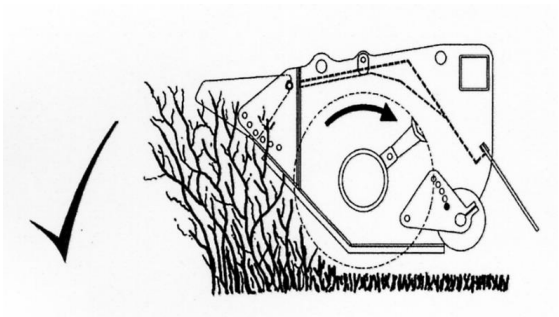

Normal Hedge Cutting

Flail is cutting upwards-reducing flying debris to minimum and leaving a tidy finish. Open adjustable front hood as required.

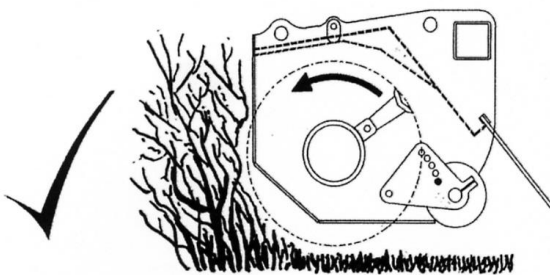

Rough Cutting

Reverse rotation if necessary. Down cut is not good for the hedge and leaves an untidy finish. Only use this position when rough cutting in heavy growth.

PROJECT BLACK FLAIL HEAD

Grass Cutting

Recommended for grass cutting

- 1.2 rotor
- Cowl wear plate
- "C" flails or "Back to Back" flails
- Optional - "Boot" flails
- Front and rear flap
- Head float and Angle Float
- Auto-pilot

Note: The 1.5m head is not recommended for grass cutting.

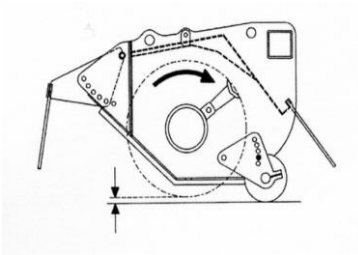

Cutting Height Adjustment

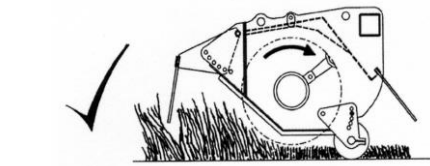
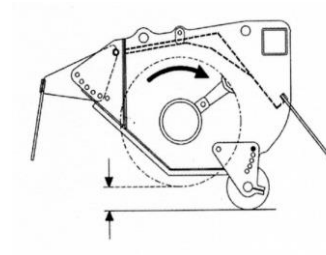

Grass Cutting

Set rear roller down to control cutting height. Have rubber flap fitted to the front and rear of head and close down the adjustable front hood to reduce flying debris to a minimum.

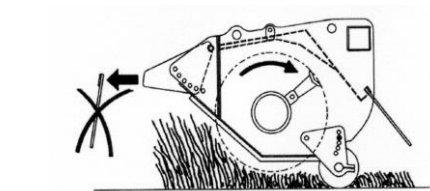
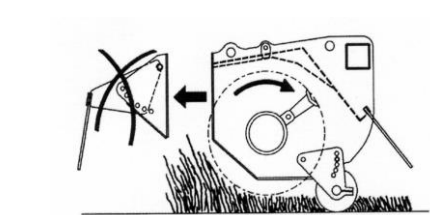

Do not operate without front and rear flap.

Do not verge mow without a rear roller.

Do not verge mow with rear roller set too high; remember the rear roller is used to control the cutting height.

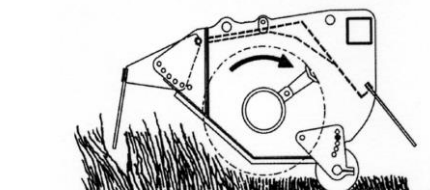

PROJECT BLACK FLAIL HEAD

Operation Warnings



Warning

Please read all the following operation warnings carefully

- Never drive the tractor with arm outstretched (except when cutting). When moving from work always first retract arms. Transport with care, metal fatigue is always caused by careless transportation and misuse. If the ground is uneven or bumpy, **slow** down.
- Read this manual and be fully familiar with all operational maintenance and safety procedures.
- Practice in open space without rotor running until familiar with controls. **Take care working the head close to the tractor as it may be possible to strike the tractor**
- Remember one of the clever features of the Twigra range is its ability to operate within a very narrow space, often within the tractor's width. This will mean it is quite possible for the flail head to foul the tractor. When in confined space the main arm will need to be slightly slewed backwards from normal working position. Practice all these positions and be very familiar with your machine before ever attempting work.
- Never operate above the recommended PTO speed of 540 R.P.M. Failure to heed this warning will result in severe damage i.e. reduced belt and pulley life (when fitted); **greatly increased oil temperature**; risk of rotor going out of balance, as well as reduced machine life, and may cause expensive repairs.
- Failure to start and stop the rotor at a low PTO speed or to operate at the correct speed will result very quickly in severe motor and/or pump damage.
- Never attempt to slew arms when fully out stretched - always retract before operating the slew. Be very careful when operating on sloping ground.
- Never attempt to slew arms with the head on the ground, always raise the head before slewing.
- Never attempt to operate the machine while going backwards. It will immediately damage the arms and possibly the flail head. Remember, before selecting reverse gear always lift the flail head out of work and retract the arms towards the tractor.
- Never change/reverse the rotor rotation until it has come to a standstill, serious damage will occur leading to premature pump and/or motor failure.

PROJECT BLACK FLAIL HEAD

Transport to work position

- Remove locking pin from slew post.
- Ensure rotor/motor switch is off.
- Engage PTO low revolutions.
- Lower main lift ram only, until main arm is vertical.
- Extend dipper arm outward.
- Slew arm forward through 90°.
- Position head till horizontal, just above ground.



Warning

Ensure slew locking pin is removed, or machine damage will occur.

Engaging Head Drive

- Select 540 rpm PTO and run with low engine revs.
- With flail head in safe position move rotor control lever or switch to 'ON'.
- **Cold start** - it is important not to run at full speed with cold oil. Run at low speed for at least 15 minutes to allow oil to warm up.
- Afterwards slowly increase engine revs to obtain correct PTO speed, 540rpm.
- Never attempt to start rotor while under load.

Disengage Head Drive

- Slowly decrease engine revolutions to a fast idle.
- Move rotor control lever or switch to 'OFF'.
- Never increase or decrease PTO speed rapidly, this could seriously damage pumps and motor.

PROJECT BLACK FLAIL HEAD

Tractor Forward Speed

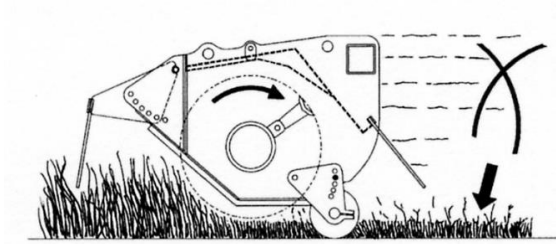

Too high a forward speed will impair the finish, leaving it looking ragged, and cause over frequent use of the break back, which will overheat the oil.

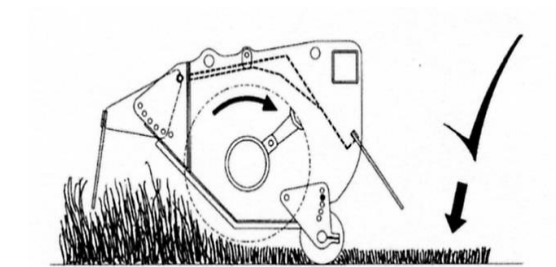

A slower forward speed improves the standard of the finish.

Cutting Sequence

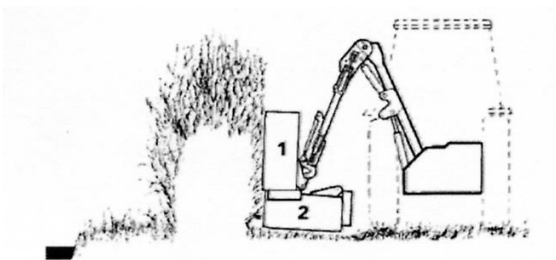

Cut field side and bottom of hedge first.

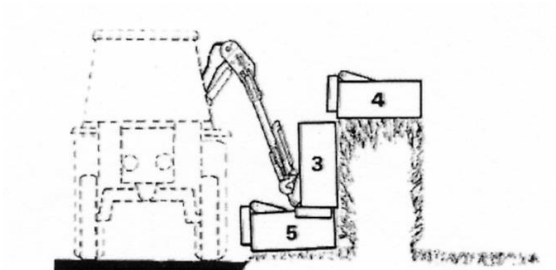

Cutting hedge from roadside

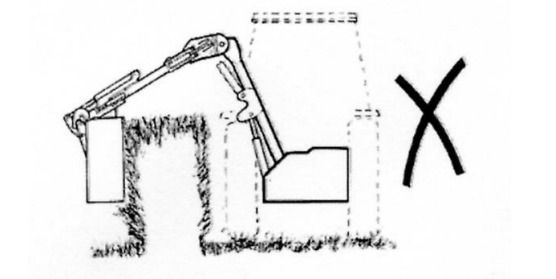

Warning

Never operate with flail rotor facing towards the tractor. This is potentially dangerous with debris being thrown towards the tractor, and unseen hazards may cause damage as the break-back cannot function.

PROJECT BLACK FLAIL HEAD

Wire Trap

This is located under the front hood. It must not be interfered with in any way
Any wire must be removed immediately.

Lower rotor to ground, select rotor control lever to 'off' and wait until rotor stops spinning. Disengage P.T.O. and stop engine before leaving cab.



Warning

Wire is extremely dangerous and must always avoided. Inspect work area before commencing, removing all loose wire and clearly marking fixed wire



PROJECT BLACK FLAIL HEAD

Hydraulic Rear Roller

The hydraulic rear roller is controlled by the tractor spool. The roller can either be raised or lowered to the desired position for either hedge or grass cutting.

The hoses to the tractor and valve are supplied with the cutting head, the hoses down the arm are supplied with the machine.

The valve mounts to the tank via the adaptors fitted. Remove the blanking plugs from the hoses and fit to the valve and run the hoses to the tractor.

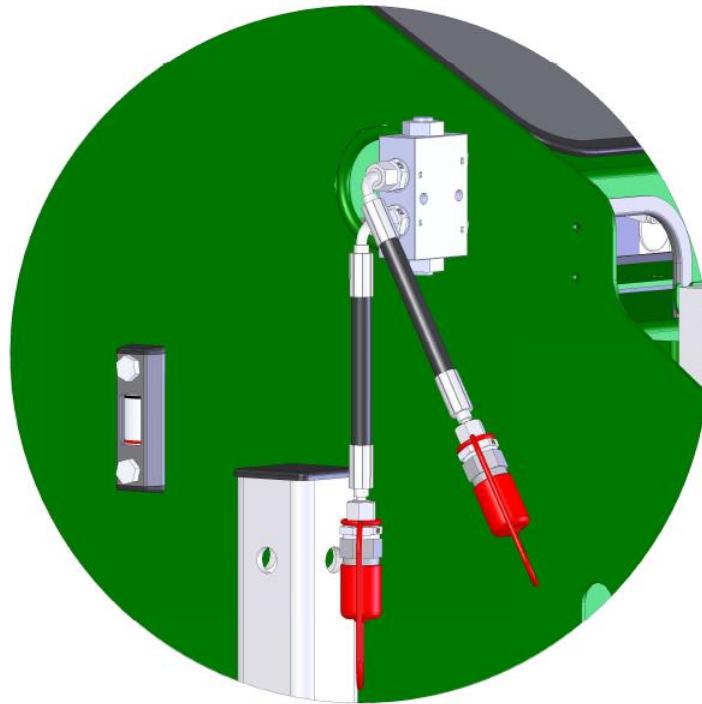

Take the hoses from the ram on the cutting head from inside the sleeving and locate the two bulkhead adaptors on the arm marked HR (you will need to remove the arm guard). Remove the blanking caps and attach the hoses. The ram will need to be operated a few times to purge any air from the system.

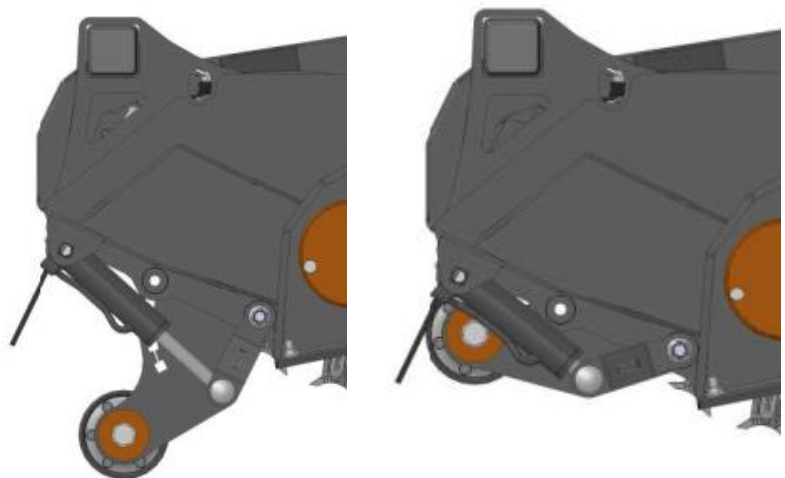
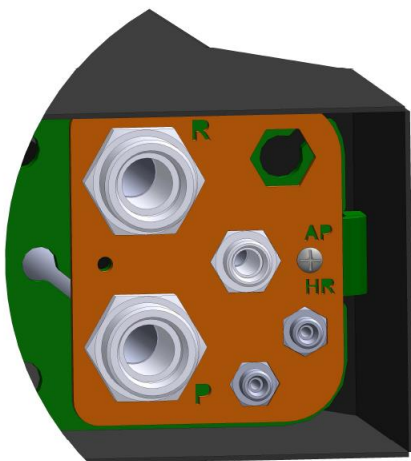

Note:

To ensure the roller moves freely it is important to keep the roller linkage clean and lubricated.

PROJECT BLACK FLAIL HEAD

Hydraulic Front Hood

The hydraulic front is also controlled by the tractor spool. The hood can either be raised or lowered to the desired position for either hedge or grass cutting. The hoses to the tractor and valve are supplied with the cutting head, the hoses down the arm are supplied with the machine. When both hydraulic roller and hood are fitted, a diverter valve is fitted to divert flow between the hood and roller rams.

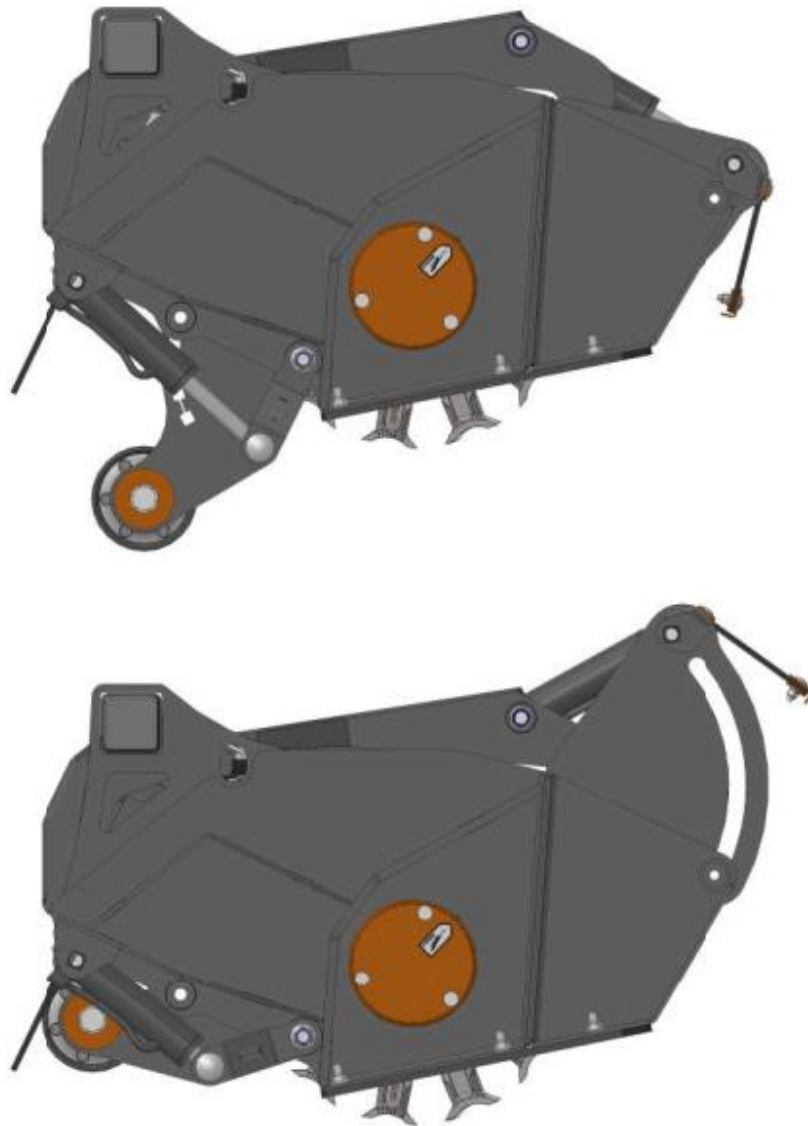

The diverter valve is operated by a switch on the controls, AUX1 on Pilot Control and Hydraulic Roller on Pro Pilot machines.



PROJECT BLACK FLAIL HEAD

Service & Maintenance

Greasing/Lubrication Points

All the following grease points need to be greased daily

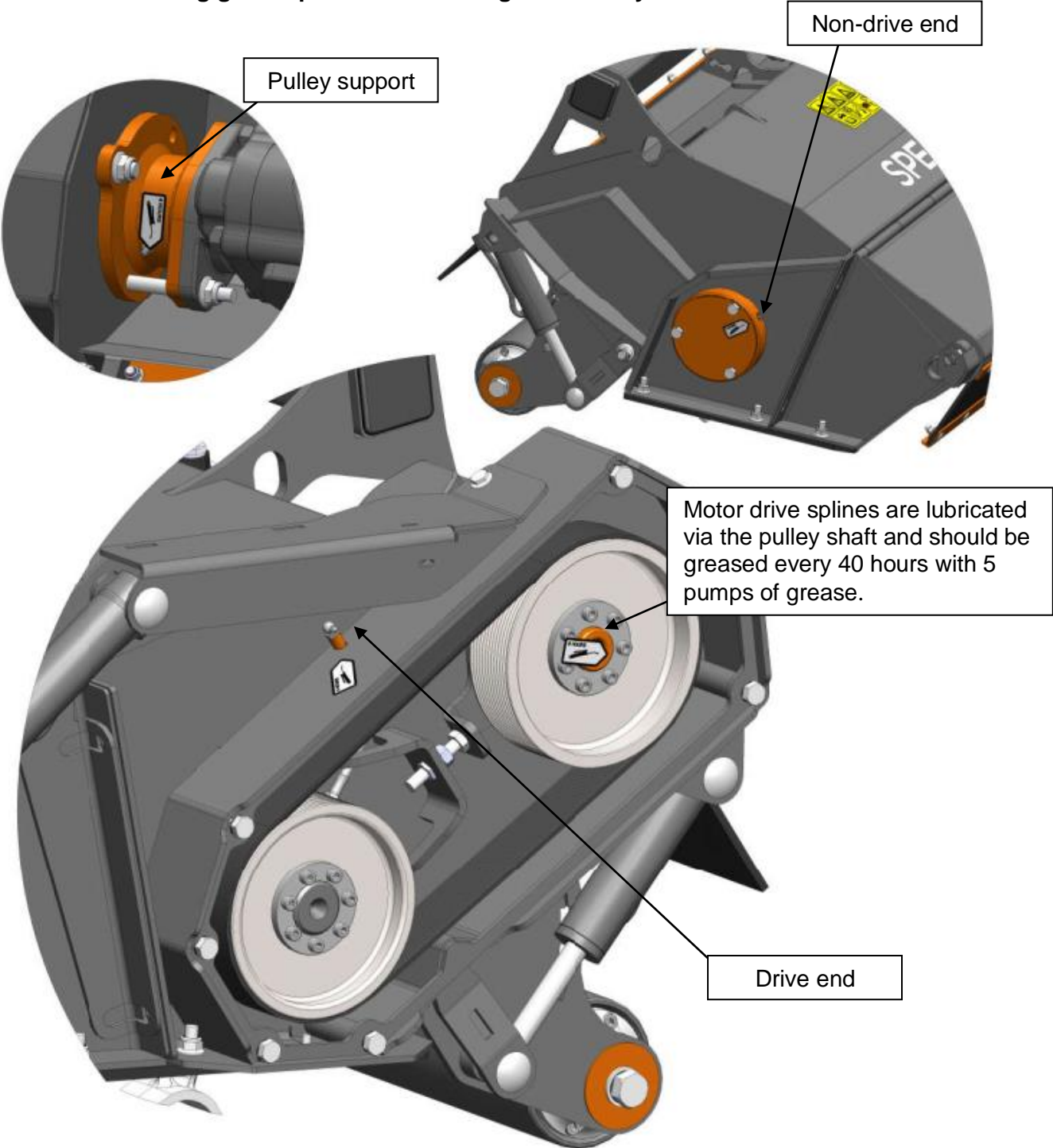

Washing your machine

Grease all your machine and optional parts after each time you wash your machine.

PROJECT BLACK FLAIL HEAD

Service & Maintenance

Hydraulic Hoses

Carefully check condition of all hoses during routine service, paying particular attention to chafed outer casing. Securely wrap with waterproof adhesive tape to stop the metal braid from rusting.

Daily inspect all hydraulic hoses and fittings to be in good order. Any damages or leaks must be rectified immediately, this is part of the daily maintenance and it is your responsibility to help ensure a long reliable working life. Spearhead provide a tool kit to enable hoses to be tightened as part of routine maintenance.

Hoses with damaged metal braid should be replaced.

When replacing hoses, quote number stamped on fitting at one end. The Spearhead hydraulic system works at very high pressure. Use only genuine hoses, a burst hose could be very dangerous.

Always replace hoses in exactly the same way they were removed, and to avoid twisting during fitting use two spanners to slacken and tighten.

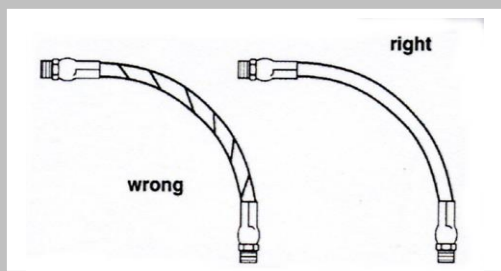

Warning

Hose is weakened when installed in twisted position. Also, pressure pulses in twisted hose tend to fatigue wire and loosen fitting connections. Design so that machine motion produces bending rather than torsion.

Always check the yellow protective sleeving is in good order, replacing sleeving is far cheaper than replacing expensive hoses.

Hose warranty is limited to replacement of hoses due to faulty materials or manufacture. Warranty will not be considered on hoses damaged by chaffing, abrasion, cuts or pinching while in work, or to damaged threads due to over tightening.

Recommended torque settings for nut

BSP (size)	Tightening (Nm)	Torque (lbs/ft)
1/4"	24	18
3/8"	33	24
1/2"	44	35
3/4"	84	62
1"	115	85

Recommended torque settings for hose unions in conjunction with bonded seals

BSP (size)	Tightening (Nm)	Torque (lbs/ft)
1/4"	34	25
3/8"	75	55
1/2"	102	75
3/4"	183	135
1"	203	150

All hose connections are of a "Parker" soft seal type and only need 1/2 a turn more than finger tight to become leak proof. When dismantling, the hose should be manually flexed to relieve any pressure, and the retaining nut slackened before complete disassembly.

PROJECT BLACK FLAIL HEAD

Service & Maintenance

Routine Checks

- Grease all bearings daily.
- Check there is no wrapping of string, plastic, grass or other debris on rotor shaft and rear roller bearings.
- Check the condition of flails and ensure all retaining bolts are tight. When flails are replaced care must be taken to maintain balance of rotor shaft, do not change to a different type.
- Flail retaining bolt and nut torque setting is 203Nm.
- Flail head is supplied centre mounted to get best travel on crowd ram.
- Never operate with any flails missing. This will cause severe vibration and lead to rapid bearing wear and quickly cause the head to crack.
- Blunt flails leave an untidy finish and absorb excessive power, when re-sharpening always wear protective clothing and goggles.
- When flails are showing severe wear, damage or cracking, they must be replaced immediately. Never attempt to weld the flails, as this will make them very brittle and extremely dangerous. Do not take risks with the cutting flails, if in doubt replace.
- When replacing flails always replace bolts, nuts and bushes with new.
- Regularly check that all rotor bearing bolts and hydraulic motor retaining bolts are tight.
- With a new machine or if new bolts have been fitted, particular attention needs to be applied to regular tightening of the new bolts. (1hr - 4hrs then daily).
- Check the condition of drive belt, ensuring they are aligned and properly tensioned to avoid any unnecessary belt wear. Remove guard for access to adjuster when tensioning the belt, and ensure it is running in line after adjustment.



Warning

When end mounted, head may foul on machine.

Do not slide head mounting bracket past centre stops to extreme end on 1.6 metre head.

PROJECT BLACK FLAIL HEAD

Service & Maintenance



Warning

Before you attempt to do any repair, service, maintenance or adjustment on your machine, ensure the engine has stopped and the key is removed. PTO is disengaged, handbrake secure, and the head is firmly on the ground.

Storage

Before storing away, thoroughly wash the machine, removing all traces of grass and dirt.

Great care must be taken when washing with high-pressure hoses, do not hold the water jet close to the paintwork. Use steam cleaners with caution, be sure to remove all detergents to avoid any discolouring or damage to paint. Grease all grease points until fresh grease shows. Slacken rotor drive belts (where fitted).

It is important where possible to store undercover to protect against rain and sunlight. Always ensure a firm level surface.

Remember: regular maintenance will greatly increase the life of the machine.

PROJECT BLACK FLAIL HEAD

Service & Maintenance

Torque Settings

The Torque figures given below are recommended maximum settings only.

Size:	Tensile strength:	Description:	Torque setting: Nm:
M8	12.9	Pulley clamps	45
M10	8.8	General fasteners	65
M12	8.8	General fasteners	114
M14	10.9	Flail bolts	200
M16	10.9	Flail bolts	203
M16	8.8	Head bracket bolts	280

Regular Service Chart

Service Hours	Service points	Grease	Check
8 hrs	Bolts are fully tightened		X
8 hrs	Condition of flails		X
8 hrs	Condition of hoses especially for chafing		X
8 hrs	Flail bolts are fully tightened		X
8 hrs	Flail head retaining bolts are fully tightened		X
8 hrs	Inspect leaks from fittings and pipes		X
8 hrs	Rotor bearing bolts are fully tightened		X
8 hrs	Rotor Bearings	X	
8 hrs	Motor bolts are fully tightened		X
8 hrs	Rear roller	X	
8 hrs	Maintain correct belt tension on head (only with belt drive heads)		X
50 hrs	Motor spline Drive	X	

PROJECT BLACK FLAIL HEAD

Trouble Shooting

Problem	Cause	Solution
Excessive belt wear	Belt and pulley condition	Replace if necessary
	Pulley alignment	Check alignment
	Incorrect belt tension	Tension belts to spec
Cut Quality	Overloading of implement	Reduce forward speed or increase height of cut
	Flails worn	Replace worn flails
	Rotor speed/direction	Check tractor PTO speed
Rotor bearing failure	Crop condition	Look for suitable conditions
	Rotor out of balance	See rotor vibration
	Wire/string in bearing	Remove wire/string
Rotor vibration	Lack of maintenance	Grease bearings to schedule
	Water in bearing	Expel water with grease
	Flails broken or missing	Replace flails
Oil overheating	Bearings worn or damaged	Replace bearings
	Rotor shaft bent	Re-balance/replace rotor
	Build up of debris	Remove debris
Hydraulics not responding	Incorrect speed	Check rotor R.P.M.
	Oil level incorrect	Fill tank to correct level
	Oil grade incorrect	Drain and refill tank with correct grade oil
Drive line broken	PTO speed too fast	Ensure the tractor's PTO speed matches implement
	Ambient temperature too high	Reduce work rate / install oil cooler
	Machine overloaded	Reduce forward speed or increase height of cut
Oil leak in pressure line	Oil level low	Fill oil to correct level
	Oil pump suction filter blocked	Replace filter element
	Oil leak in pressure line	Check machine of leaks
Drive line broken	Drive line broken	Check pump is rotating

PROJECT BLACK FLAIL HEAD

Pump & Motor Failure

There are many reasons for pump and motor failure, cavitations (suction of air), peak pressure, contamination. These can be avoided by the following:

- Never run out of oil
- Never run a cold machine straight up to speed, ensure the engine idle speed before engage/disengage the head motor.
- Never increase or decrease engine speed quickly
- Regularly check that suction hose and pump fittings are tight.
- Never stop or start the rotor at 540 R.P.M.
- Never cause sudden movements to the arms via your controls or bumps in the ground as pressure spikes will be transmitted back to the pump, resulting in failure.
- Avoid striking the rotor on obstacles i.e., road gullies as this causes pressure spikes.
- Never transport the machine with the PTO in gear.
- Never select 1000 speed gear for economy start up, speed is too high.
- Never operate above recommended PTO speed 540 R.P.M. and risk overheating.

Remember, pump and motor warranty is limited to replacement due to faulty materials or manufacture. Cavitations, contamination and peak pressures are easily detected on inspection, warranty will not be considered if failure is due to misuse.

Spearhead Machinery Ltd
Station Road
Salford Priors
Evesham
Worcestershire
WR11 8SW
Tel: 01789 491860
Fax: 01789 778683
www.spearheadmachinery.com
enquiries@spearheadmachinery.com