

Spearhead

EXCEL 470 Reach Mower



Edition 1.2 - Dec 2011
PART No. 8999063

HANDBOOK

Spearhead Excel 470

CE Declaration of Conformity, Conforming to EU Machinery Directive 2006/42/EC

We, Spearhead Machinery Ltd, Green View, Salford Priors, Evesham,
Worcestershire, WR11 8SW hereby declare that:

Product

Product Code.....

Serial No.....

Type.....

Manufactured by: Alamo Manufacturing Services (UK) Limited, Station Road, Salford
Priors, Evesham, Worcestershire, WR11 8SW

Complies with the required provisions of the Machinery Directive 2006/42/EC. The
Machinery Directive is supported by the following harmonized standards:

- BS EN ISO 14121-1 (2007) Safety of Machinery – Risk Assessment, Part 1:
Principles Part 2: Practical Guide and Examples of Methods.
- BS EN ISO 12100-1 (2010) Safety of Machinery – Part 1: Basic Terminology and
Methodology Part 2: Technical Principles.
- BS EN 349 (1993) + A1 (2008) Safety of Machinery – Minimum Distances to
avoid the Entrapment of Human Body Parts.
- BS EN 953 (1998) Safety of Machinery – Guards General Requirements for the
Design and Construction of Fixed and Movable Guards.
- BS EN 982 (1996) + A1 (2008) Safety Requirements for Fluid Power Systems
and their Components. Hydraulics.

The EC Declaration only applies if the machine stated above is used in accordance with
the operating instructions.

Signed



(On behalf of Spearhead Machinery Ltd)

Status

General Manager

Date

01/12/2011

Spearhead Excel 470

Contents

General Information	3
Features	5
Safety Information	6
Introduction	10
Tractor Selection	11
Hydraulic Oil	13
Machine Attachment – <i>Chain Type Stabilizer</i>	14
Machine Attachment – <i>Link Type Stabilizer</i>	17
Operation Information	21
Rotor Rotation Direction	21
Rotor Control	22
Cable Controls – <i>Levers and Symbols</i>	23
Cable Controls – <i>Lever Functions</i>	24
Hydraulic Controls – <i>Cutting Position</i>	25
Cutting Head	25
Transportation	26
Machine Removal	27
Maintenance	28
Warranty	29

Spearhead Excel 470

General Information

Noise

The equivalent daily personal noise exposure from this machine, measured at the operators' ear, is within the range 78 – 85 dB.

These figures apply to a normal distribution of use where the noise fluctuates between zero and maximum. The figures assume that the machine is fitted to a tractor with a quiet cab with the windows closed in a generally open environment. We recommend that the windows are kept closed.

With the cab rear window open the equivalent daily personal noise exposure will increase to a figure within the range 82 – 88 dB.

At equivalent daily noise exposure levels of between 85 and 90 dB, ear protection is recommended, it should be used if any window is left open.

Spearhead Excel 470

General Information

Read this manual before fitting or operating the machine. Whenever any doubt exists contact your dealer or Spearhead Machinery Limited Service Department for advice and assistance.

Use only Spearhead Machinery Limited 'Genuine Service Parts' on Spearhead Machinery Limited equipment and machines.

DEFINITIONS: The following definitions apply throughout this manual:

WARNING:

An operating procedure, technique etc which can result in personal injury or loss of life if not observed carefully.

CAUTION:

An operating procedure, technique etc which can result in the damage of either machine or equipment if not observed carefully.

NOTE:

An operating procedure, technique etc which is considered essential to emphasize.

LEFT & RIGHT HAND:

This term is applicable to the machine when fitted to the tractor and viewed from the rear, this also applies to tractor references.

To be assured of the latest design improvements purchase your '**Genuine Replacements**' from the **Original Equipment Manufacturer: SPEARHEAD MACHINERY LIMITED** through your local Dealer or Stockist.

Always quote:

- **Machine Type**
- **Serial Number**
- **Part Number**

Record the Serial No. of your machine on this page and always quote this number when ordering spares along with the type and model of tractor your machine is fitted to.

Machine Serial No.	Model Details:	Installation Date:
Dealer Name:		Dealer Telephone:
Dealer Address:		

Spearhead Excel 470

Features

Cable Controls

Linkage Mounted

Right or Left Hand Cutting

1.2m Double Skin Head

150 litre Hydraulic Reservoir

Independent Hydraulics

245° of Head Angle – Constant Motion

Built in Head Floatation

Optional Lift Float

Mechanical Breakback

Spearhead Excel 470

Safety Information

This machine has the potential to be extremely dangerous, in the wrong hands it can kill or maim. It is therefore imperative that the owner, and the operator of this machine, read the following section to ensure that they are both fully aware of the dangers that do, or may exist, and their responsibilities surrounding its use.

The operator of this machine is responsible not only for their own safety but equally for the safety of others who may come into the close proximity of the machine, as the owner you are responsible for both.

POTENTIAL SIGNIFICANT DANGERS ASSOCIATED WITH THE USE OF THIS MACHINE:

- ▲ *Being hit by debris thrown by rotating components.*
- ▲ *Being hit by machine parts ejected through damage during use.*
- ▲ *Being caught on a rotating power take-off (PTO) shaft.*
- ▲ *Being caught in other moving parts i.e.: belts, pulleys and cutting heads.*
- ▲ *Electrocution from Overhead Power Lines (by contact with or 'flashover' from).*
- ▲ *Being hit by cutting heads or machine arms as they move.*
- ▲ *Becoming trapped between tractor and machine when hitching or unhitching.*
- ▲ *Tractor overbalancing when machine arm is extended.*
- ▲ *Injection of high pressure oil from hydraulic hoses or couplings.*
- ▲ *Machine overbalancing when freestanding (out of use).*
- ▲ *Road traffic accidents due to collision or debris on the road.*

BEFORE USING THIS MACHINE YOU MUST:

- ▲ Ensure you read all sections of the operator handbook.
- ▲ Ensure the operator is, or has been, properly trained to use the machine.
- ▲ Ensure the operator has been issued with and reads the operator handbook.
- ▲ Ensure the operator understands and follows the instructions in operator handbook.

Spearhead Excel 470

- ▲ Ensure the tractor front, rear and side(s) are fitted with metal mesh or polycarbonate guards of suitable size and strength to protect the operator against thrown debris or parts.
- ▲ Ensure tractor guards are fitted correctly, are undamaged and kept properly maintained.
- ▲ Ensure that all machine guards are in position, are undamaged, and are kept maintained in accordance with the manufacturer's recommendations.
- ▲ Ensure flails and their fixings are of a type recommended by the manufacturer, are securely attached and that none are missing or damaged.
- ▲ Ensure hydraulic pipes are carefully and correctly routed to avoid damage by chaffing, stretching or pinching and that they are held in place with the correct fittings.
- ▲ Always follow the manufacturer's instructions for attachment and removal of the machine from the tractor.
- ▲ Check that the machine fittings and couplings are in good condition.
- ▲ Ensure the tractor meets the minimum weight recommendations of the machine manufacturer and that ballast is used as necessary.
- ▲ Always inspect the work area thoroughly before starting to note obstacles and remove wire, bottles, cans and other debris.
- ▲ Use clear suitably sized warning signs to alert others to the nature of the machine working within that area. Signs should be placed at both ends of the work site. (It is recommended that signs used are of a size and type specified by the Department of Transport and positioned in accordance with their and the Local Highways Authority guidelines).
- ▲ Ensure the operator is protected from noise. Ear defenders should be worn and tractor cab doors and windows must be kept closed. Machine controls should be routed through proprietary openings in the cab to enable all windows to be shut fully.
- ▲ Always work at a safe speed taking account of the conditions i.e.: terrain, highway proximity and obstacles around and above the machine.
- ▲ Extra special attention should be applied to Overhead Power Lines. Some of our machines are capable of reach in excess of 8 metres (26 feet) this means *they* have the potential to well exceed, by possibly 3 metres (9' 9"), the lowest legal minimum height of 5.2 metres from the ground for 11,000 and 33,000 volt power lines. It cannot be stressed enough the dangers that surround this capability, it is therefore vital that

Spearhead Excel 470

the operator is fully aware of the maximum height and reach of the machine, and that they are fully conversant with all aspects regarding the safe minimum distances that apply when working with machines in close proximity to Power Lines. (Further information on this subject can be obtained from the Health & Safety Executive or your Local Power Company).

- ▲ Always disengage the machine, kill the tractor engine, remove and pocket the key before dismounting for any reason.
- ▲ Always clear up all debris left at the work area, it may cause hazard to others.
- ▲ Always ensure when you remove your machine from the tractor that it is left in a safe and stable position using the stands and props provided and secured if necessary.

WHEN NOT TO USE THIS MACHINE:

- ▲ *Never attempt to use this machine if you have not been trained to do so.*
- ▲ *Never uses a machine until you have read and understood the operator handbook, are familiar with, and practiced the controls.*
- ▲ *Never use a machine that is poorly maintained.*
- ▲ *Never use a machine if guards are missing or damaged.*
- ▲ *Never use a machine on which the hydraulic system shows signs of wear or damage.*
- ▲ *Never fit, or use, a machine on a tractor that does not meet the manufacturer's minimum specification level.*
- ▲ *Never use a machine fitted to a tractor that does not have suitable front, rear and side(s) cab guarding made of metal mesh or polycarbonate.*
- ▲ *Never use the machine if the tractor cab guarding is damaged, deteriorating or badly fitted.*
- ▲ *Never turn a machine cutting head to an angle that causes debris to be ejected towards the cab.*
- ▲ *Never start or continue to work a machine if people are nearby or approaching - Stop and wait until they are at a safe distance before continuing.*
- ▲ *Never attempt to use a machine on materials in excess of its capability.*

Spearhead Excel 470

- ▲ Never use a machine to perform a task it has not been designed to do.
- ▲ Never operate the tractor or machine controls from any position other than from the driving seat, especially whilst hitching or unhitching the machine.
- ▲ Never carry out maintenance of a machine or a tractor whilst the engine is running – the engine should be switched off, the key removed and pocketed.
- ▲ Never leave a machine unattended in a raised position – it should be lowered to the ground in a safe position on a level firm site.
- ▲ Never leave a tractor with the key in or the engine running.
- ▲ Never carry out maintenance on any part or component of a machine that is raised unless that part or component has been properly substantially braced or supported.
- ▲ Never attempt to detect a hydraulic leak with your hand – use a piece of cardboard.
- ▲ Never allow children near to, or play on, a tractor or machine under any circumstances.

Although the information given here covers a wide range of safety subjects, it is impossible to predict every eventuality that can occur under differing circumstances whilst operating a machine of this type. No advice given here can replace 'good common sense' and 'total awareness' at all times, but will go a long way towards the safe use of your Spearhead machine.

Spearhead Excel 470

Introduction

The Spearhead range of Boom Flail Trimmers has been designed with the farmer and the contractor in mind - which has resulted in a boom flail with a very high specification - with many features not found on other machines.

The construction is of welded steel fabricated assemblies - with many and varied options available covering such things as controls, hydraulics, heads, booms etc. The cutting head is of a 'double skin' construction.

The cutting flail blades offered for your Spearhead machines are: -

- a) Heavy, double edged design (one piece)
 - For 'Upward' or 'Downward' cutting
 - Suitable for hedge cutting

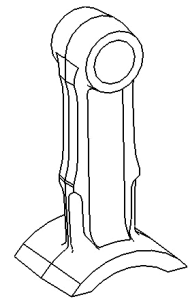

- b) Heavy single edge blade flail (C Flail)
 - Cuts one direction only
 - For grass cutting

- c) Back to Back - on shackle (in pairs)
 - For 'Upward' or 'Downward' cutting
 - Suitable for grass/mowing

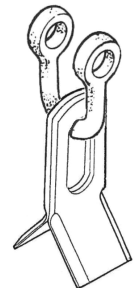

- d) Boot flail - on shackle
 - Cuts one direction only
 - For grass cutting and hedge trimming

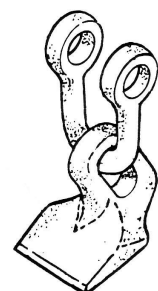

The cutter head design is of a 'double skin' construction for greater strength and longer life.

Spearhead Excel 470

Safety Break-back

A 'swing link breakback' system is built into the machine; this offers a degree of protection to machine components if an obstruction is encountered during normal work.

The break back link will operate if the machine is overloaded i.e. a dense patch of vegetation, too high a forward speed, and when working up hill.

The tractor must be halted and flail head manoeuvred around the obstacle, the machine then reset before continuing.



Warnings

Never attempt to operate the machine when travelling backwards, the break back will not function and any damage caused will not be considered warranty.

The break back feature does not excuse the machine operator of their need to be aware of obstacles and to avoid hazards. It is your responsibility to maintain a long reliable working life.

Two parking stand legs are fitted to the machine, which once the machine has been attached to the tractor should be folded away in the 'stow' position.

The machine has 'angle head flotation' as standard –this is engaged by moving the head rotation lever beyond the normal actuation range into a detented 'float' position. 'Lift float' is available as an option on the machine.

All machines have a relief valve in the primary ram system, this limits the pressure which can be generated in the drop side of the cylinder – the cutting head cannot therefore be 'driven' into the ground in any circumstances.

Tractor Selection

Tractor Specifications

Tractor size must be a minimum of 45kW (60 HP) – 3000kg

Tractors must be equipped with a power take off (PTO) shaft that must run at 450 rpm during operation. The PTO shaft should run clockwise when viewed from the rear of the tractor and ideally be of a 1 $\frac{3}{8}$ " S.A.E. – 6 spline shaft type to enable a standard PTO shaft to be connected.

The tractor should have counterbalance weights (*on approved mountings*) fitted if necessary and/or ballasted wheels to ensure stability of the unit at all times.

Stability may be further increased with a wider track setting on the tractors rear wheels – *contact your local dealer or tractor agent for specific advice on this subject.*

Four wheel drive tractors have extra weight inbuilt plus larger front wheels, this is an advantage in keeping the unit stable.

Spearhead Excel 470

Tractor/Operator Guarding

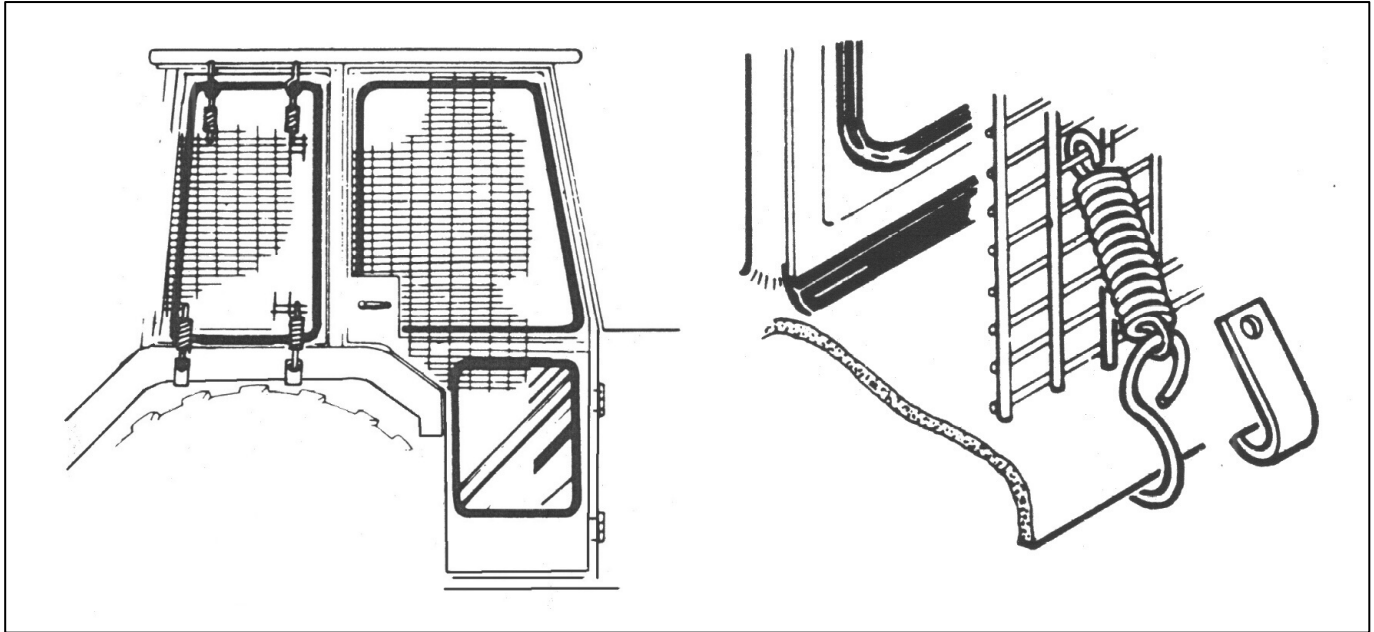

Use a tractor with 'safety glass' windows if possible and fit **Operator Guard** (*Part No. OPT0603*) using the hooks provided.

Shape 'safety protection material' to cover all vulnerable areas. Remember the driver must be looking through 'safety protection' at the flail head in any working position. If the windows are not laminated safety glass polycarbonate glazing must also be fitted.

If the tractor has a roll bar only, a frame must be made to carry both mesh and polycarbonate glazing.

Ensure the operator is guarded by 'safety protection' whatever position the machine is in and that the protection is such that it does not interfere with tractor and machine functions or obstruct the operator's vision.

Spearhead Excel 470

Hydraulic Oil

IMPORTANT

The hydraulic system will have been 'run-up' and checked at the factory prior to the machines despatch, where hydraulic oil is used - and is recommended for the machine. The hydraulic tank will have oil in it when delivered.

Oil tank capacity for the Excel 470 is 150 Litres

The user must ensure the hydraulic tank is full of 'RANDO 46' hydraulic oil (or an equivalent recommended oil – refer to oil chart below) before attempting to start the machine from new.

Recommended Oils

Manufacturer	<i>Cold or Temperate Climate</i>	<i>Hot Climate</i>
BP	Bartran 46 Energol HLP-HM 46	Bartran 68 <i>Energol HLP-HM 68</i>
CASTROL	<i>Hyspin AWH-M 46</i>	<i>Hyspin AWH-M 68</i>
COMMA	<i>Hydraulic Oil LIC 15</i>	<i>Hydraulic Oil LIC 20</i>
ELF	Hydrelf HV 46 <i>Hydrelf XV 46</i>	Hydrelf HV 68
ESSO	<i>Univis N 46</i>	<i>Univis N 68</i>
FUCHS (UK/Non UK markets*)	Renolin 46 <i>Renolin HVZ 46</i> <i>Renolin CL46/B15*</i> <i>Renolin AF46/ZAF46B*</i>	Renolin 68 <i>Renolin HVZ 68</i> <i>Renolin CL68/B20*</i> <i>Renolin AF68/ZAF68B*</i>
GREENWAY	<i>Excelpower HY 68</i>	<i>Excelpower HY 68</i>
MILLERS	Millmax 46 <i>Millmax HV 46</i>	Millmax 68 <i>Millmax HV 68</i>
MORRIS	Liquimatic 5 <i>Liquimatic HV 46</i> <i>Triad 46</i>	Liquimatic 6 <i>Liquimatic HV 68</i> <i>Triad 68</i>
SHELL	Tellus 46 <i>Tellus T46</i>	Tellus 68 <i>Tellus T68</i>
TEXACO	RandoHD 46 <i>Rando HDZ 46</i>	Rando HD 68 <i>Rando HDZ 68</i>
TOTAL	<i>Equivis ZS 46</i>	<i>Equivis ZS 68</i>

The tank top filter/breather is equipped with a strainer to ensure all oil is strained when being put into tank. The strainer basket - should never be removed, all hydraulic oil filling is to be done through the strainer.

WARNING

Never mix hydraulic oils - if another supplier's oil is to be used ensure it is suitably compatible oil - *Check with your oil supplier or machine manufacturer first.*

Attaching the Machine – Chain Type Stabilizer

IMPORTANT: -

Attachment of the machine to the tractor should always be performed on a firm level site.

- Remove locking pins and lift pins supplied with Hedge trimmer from lower link positions of linkage frame.
- Slowly and very carefully reverse the tractor towards the machine linkage frame.
- With care - ensure that tractor lower link ball eyes fit between lower jaws of linkage frame and that pin holes are aligned.

SWITCH OFF TRACTOR ENGINE & ENSURE HANDBRAKE IS ON

- With holes of tractor lower link eyes in line with lower jaw holes of frame - the lower linkage pins should now be refitted – *fit spacers if required to prevent side movement of link arms.*
- Secure lift pins in position using locking pins.
- Attach top link along with the upper stabilizer plates to the tractor selecting the highest possible position avoiding any load sensing properties.
- Connect top link to the machines top link point.
- Raise the machine on the tractor's linkage to a position where the stub shaft of the tractors PTO drive and the stub shaft of the machine gearbox are horizontally aligned.
Note: As lift occurs be aware that the machine may tilt slightly.
- Tractor lower linkage check chains or bars should now be tightened to ensure tractor arms are locked and machine is positioned centrally to the tractor.
- Adjust top link to bring the machine into the vertical position.
- Thread stabilizer chain through the holes in both upper stabilizer plates leaving an equal length of chain on each side.
- Raise machine slightly and thread each end of the chain through the holes of the stabilizer lower plates on both sides – pull as tight as possible and lock in position in the chain slot of the hole. Lower machine enough only to exert tension on the chain.
- Fit PTO shaft and attach guard chains to a suitable fixed location – *refer to link type stabilizer section for details of the PTO measuring, cutting and fitting procedure.*
- Raise and secure the stand legs into the stowed position.
- Fit operator safety guarding to tractor windows.

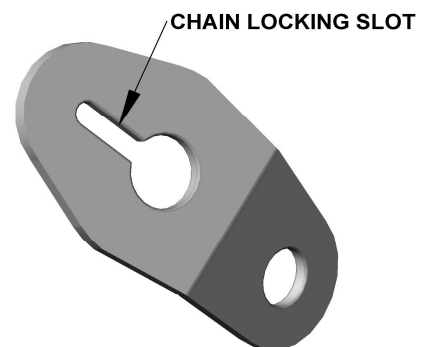

Lower Stabilizer Plate

Spearhead Excel 470

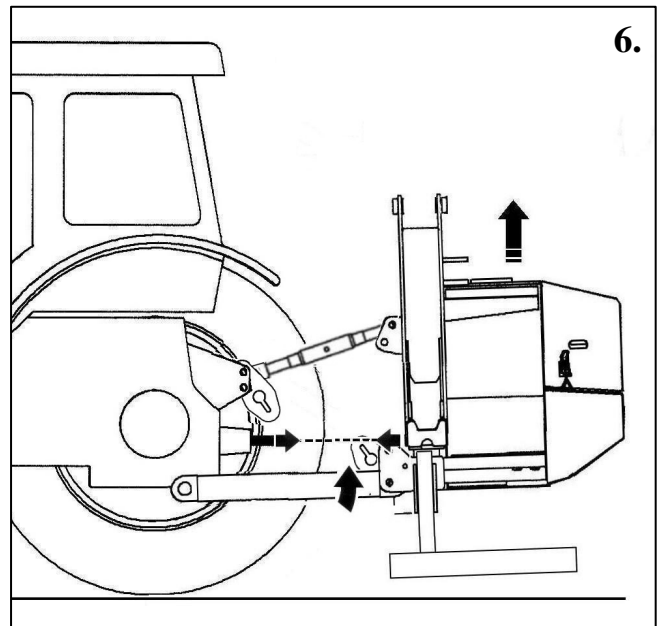
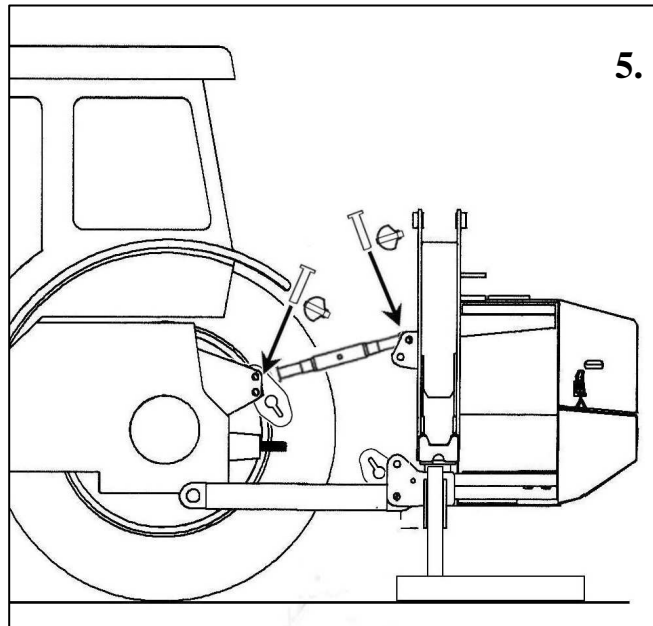
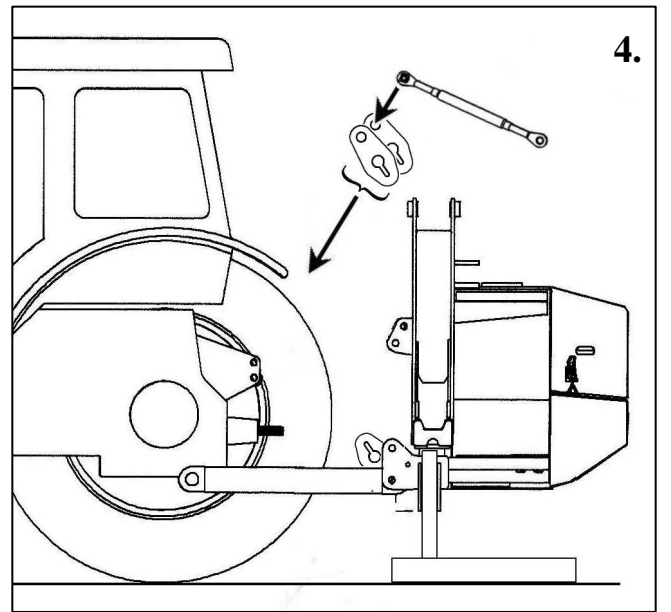
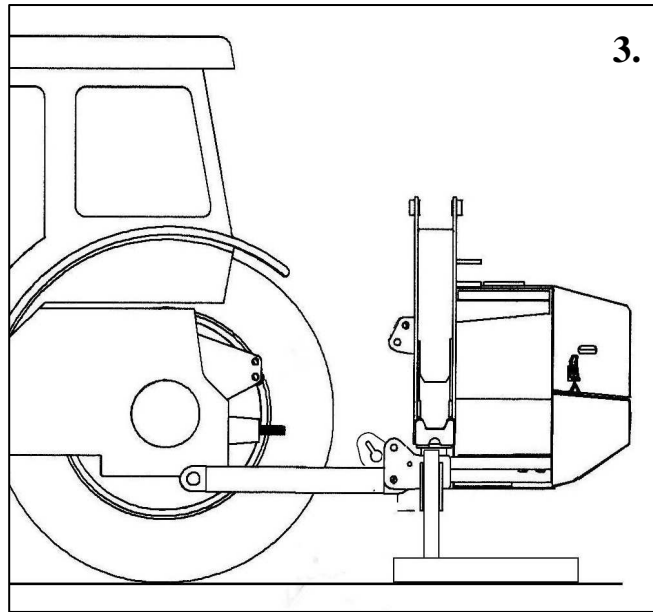
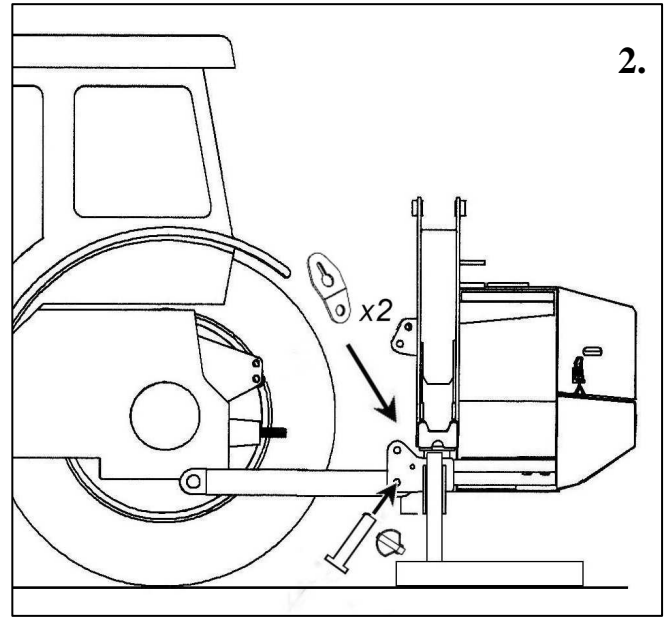
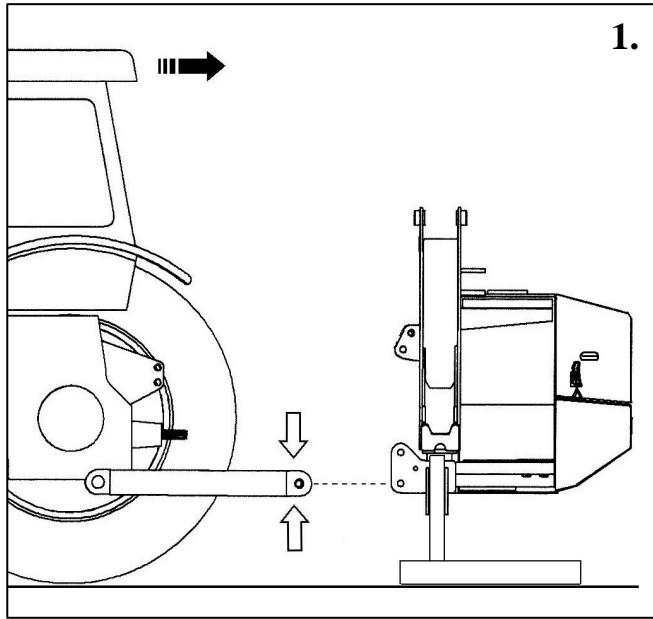

Spearhead Excel 470

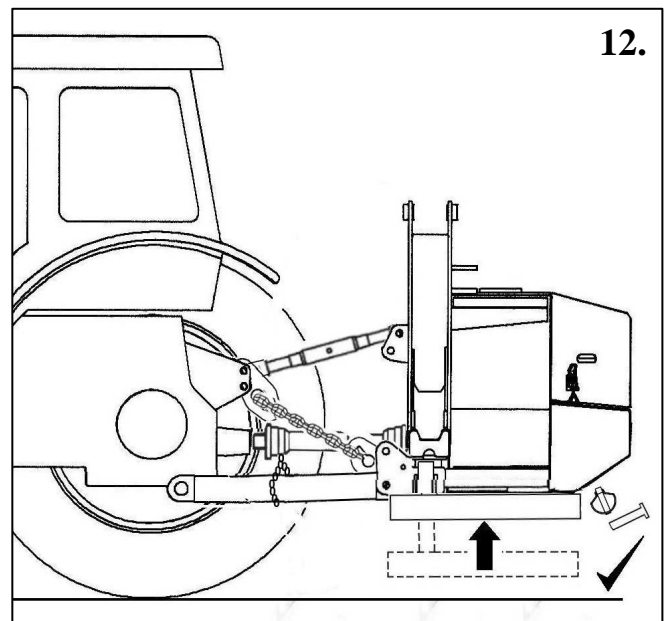
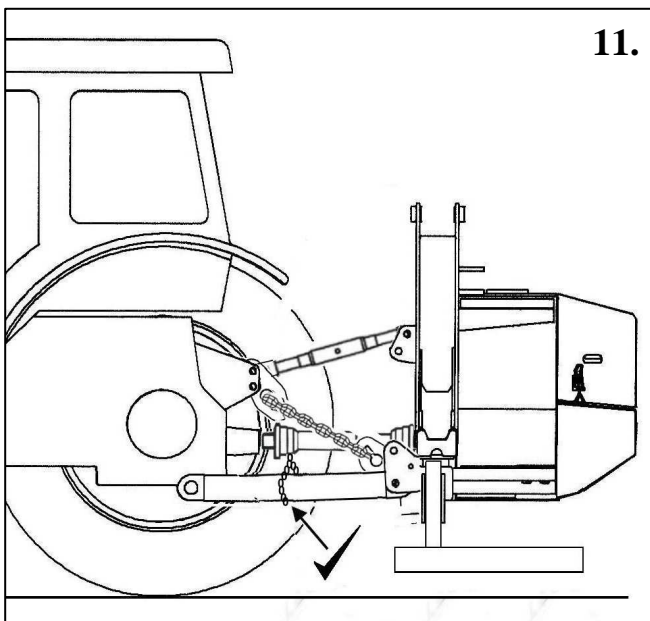
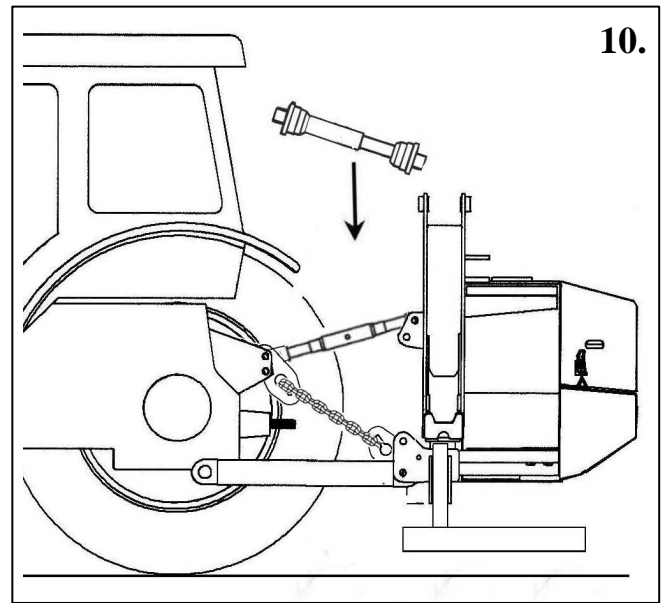
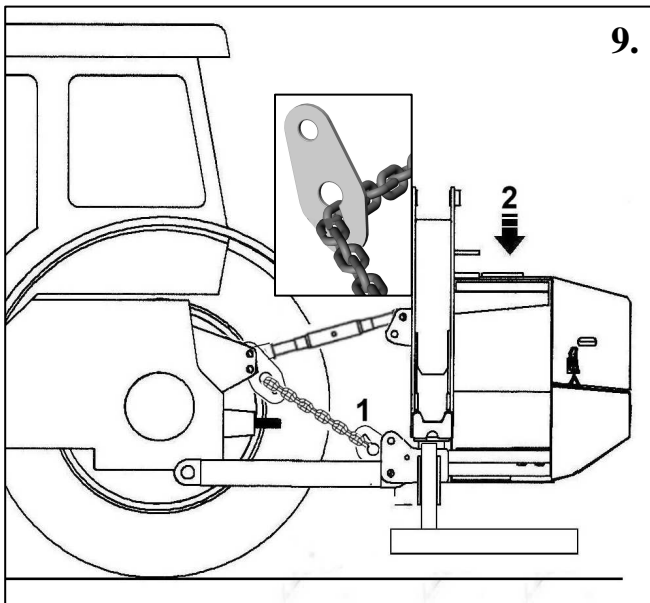
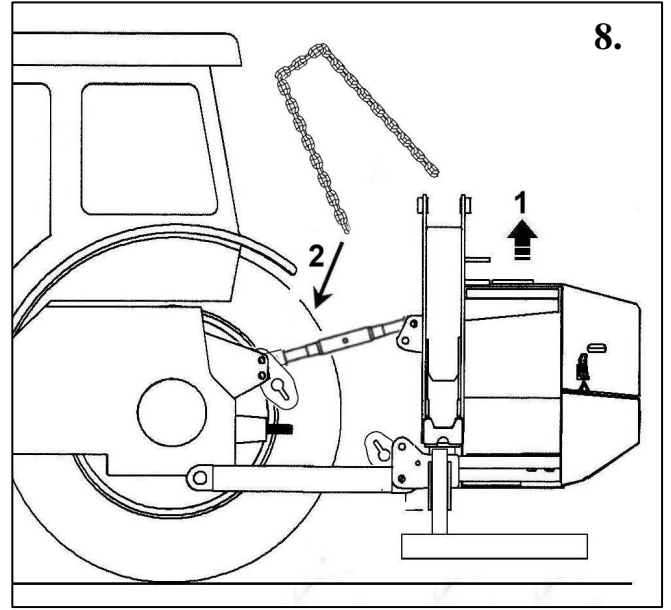
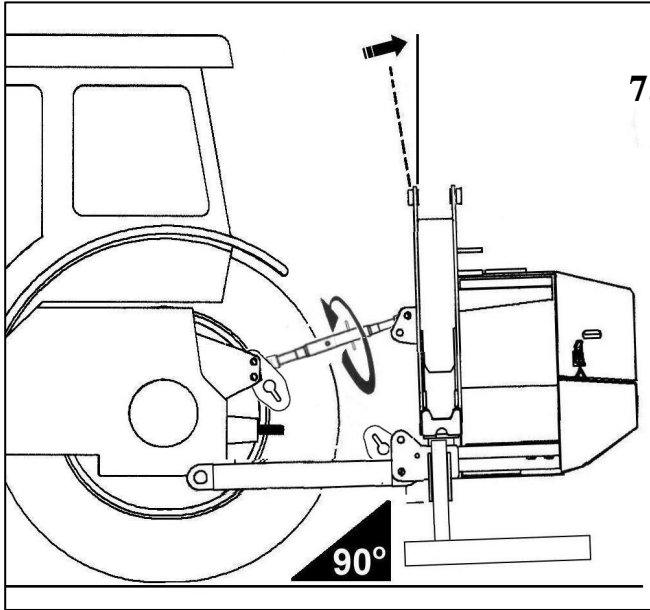

Spearhead Excel 470

Attaching the Machine – Link Type Stabilizer

IMPORTANT: -

Attachment of the machine to the tractor should always be performed on a firm level site.

- Remove locking pins and lift pins supplied with Hedge trimmer from lower link positions of linkage frame.
- Slowly and very carefully reverse the tractor towards the machine linkage frame.
- With care - ensure that tractor lower link ball eyes fit between lower jaws of linkage frame and that pin holes are aligned.

SWITCH OFF TRACTOR ENGINE & ENSURE HANDBRAKE IS ON

- With holes of tractor lower link eyes in line with lower jaw holes of frame - the lower linkage pins should now be refitted – *fit spacers if required to prevent side movement of link arms.*
- Secure lift pins in position using locking pins.
- Fit and secure the stabiliser's top link yoke to the tractor's top link - select the highest available position avoiding any load sensing properties.
- Attach top link to machines top link point.
- Raise the machine on the tractor's linkage to a position where the stub shaft of the tractors PTO drive and the stub shaft of the machine gearbox are horizontally aligned. *Note: As lift occurs be aware that the machine may tilt slightly.*
- Tractor lower linkage check chains should now be tightened to ensure tractor arms are locked and machine is positioned centrally to the tractor.
- Adjust top link to bring the machine into the vertical position.
- Check the PTO shaft length.
When connected from tractor to machine it should engage by 1/3rd of the total shaft length, i.e. male part should be halfway from the end to fully 'bottomed' out. Do not use the machine until this has been cut to the correct length.

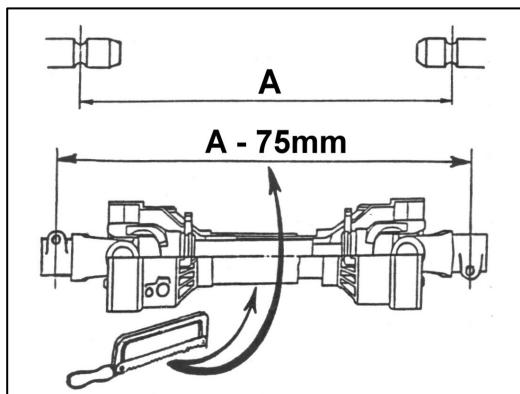

Measure the PTO shaft and cut to the dimension shown – the finished length of the PTO shaft should be 75mm (3") less than the measured distance 'A' - between tractor shaft and gearbox stub shaft – to enable fitting.

NOTE:

For subsequent use with different tractors measure again, there must be a minimum shaft overlap of 150mm (6").

Spearhead Excel 470

- Fit the PTO shaft.
- Ensure the shaft is correctly fitted to the splines at both ends.
- Fit the anti-spin chains of the PTO guard to a suitable rigid non-turning location.
- Raise stand legs into their stowage position and secure with locking pins.
- Fit mesh safety screens - they are designed to be fitted to the cutting head side of tractor cab (i.e. for left-hand cut machines to left-hand side of cab). Secure in position using the fixings provided ensuring that all exposed glass areas on the cutting side of the tractor are fully protected. **All glass screens on the relevant side of cab must be protected.**
- Fix valve control handles into position:-
- Control levers are supplied bolted together as a complete unit along with a mounting bracket for attachment within the tractor - *the number of controllers in the set can vary dependent on the particular model or specification machine*. The mounting bracket should be positioned on the inner wing face of the tractor cab in a suitable position for ease of operation.

It is suggested that for three and four bank controller sets the bracket is fitted to the left-hand wing for left-hand cut machines and right-hand wing for right-hand cut machines. In the case of electric machines with a single-bank rotor controller is required it is suggested that the bracket is fitted to the opposite side for the control of the cutting direction and that the joystick mounting bracket is fitted to the cutting side - both brackets are however the same.

Spearhead Excel 470

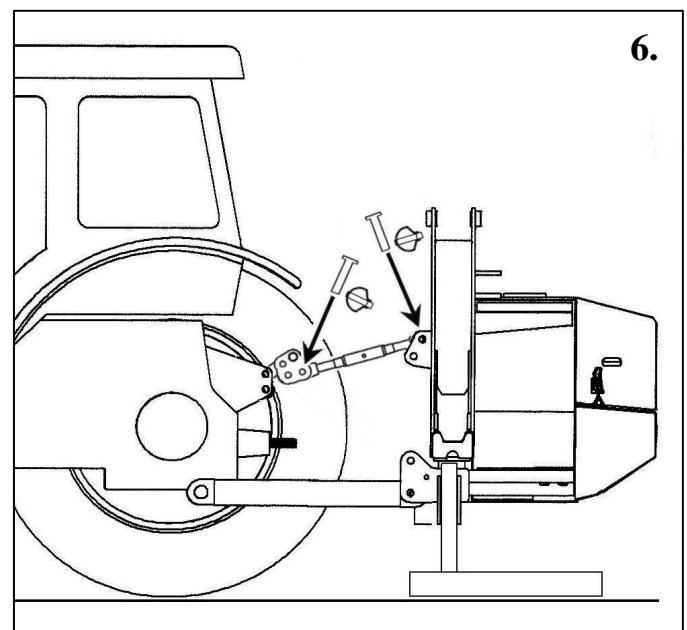
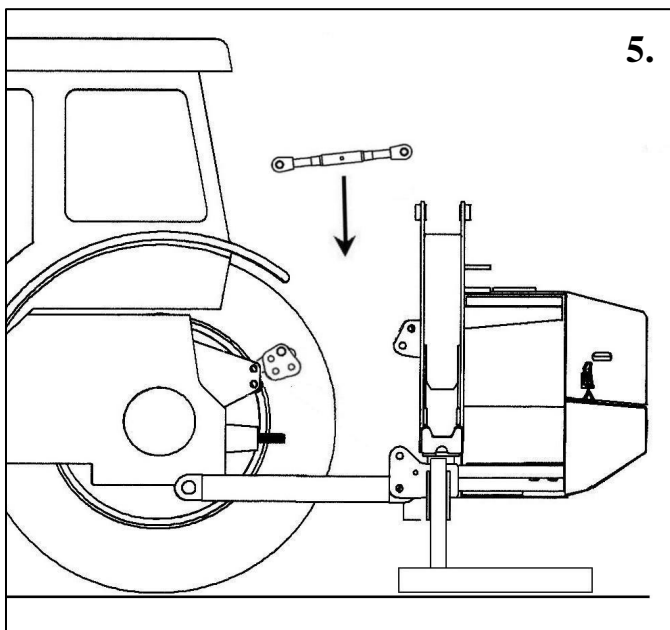
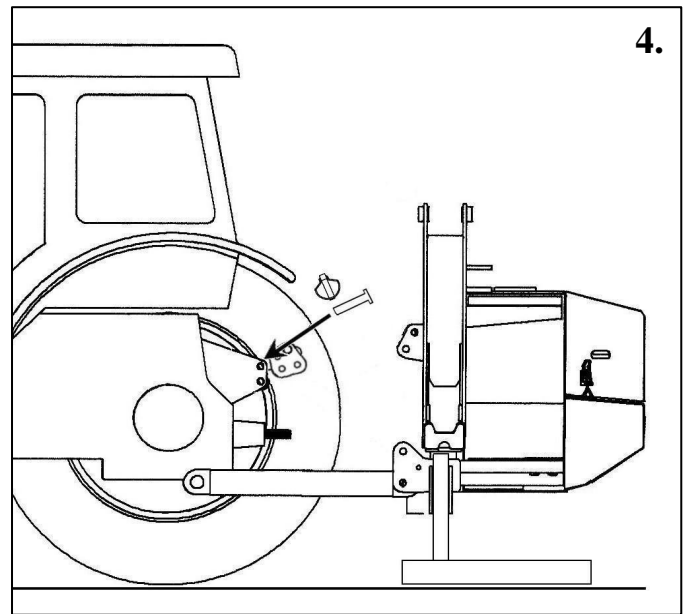
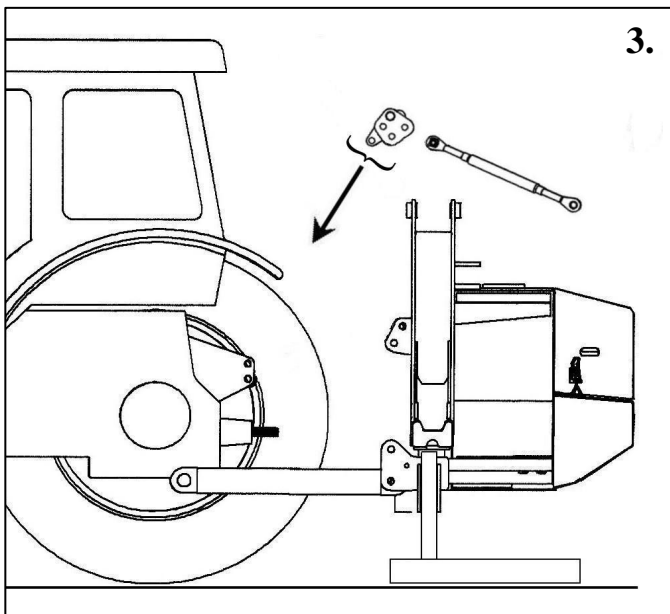
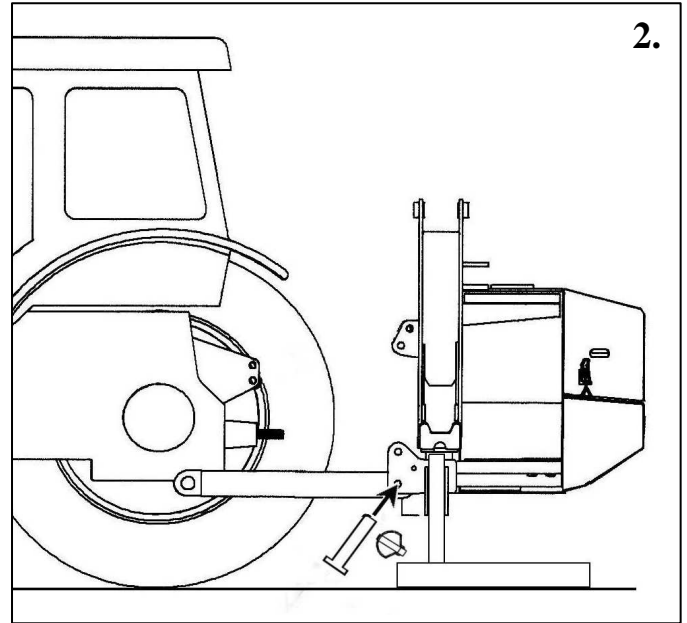
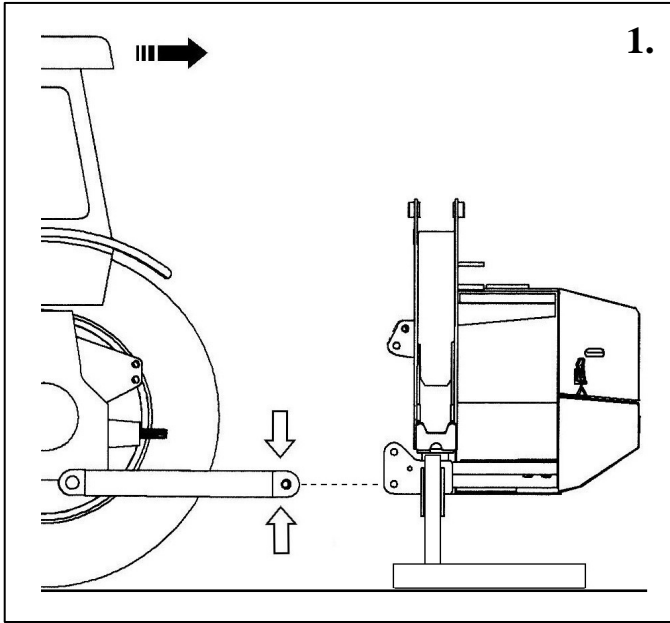

Spearhead Excel 470

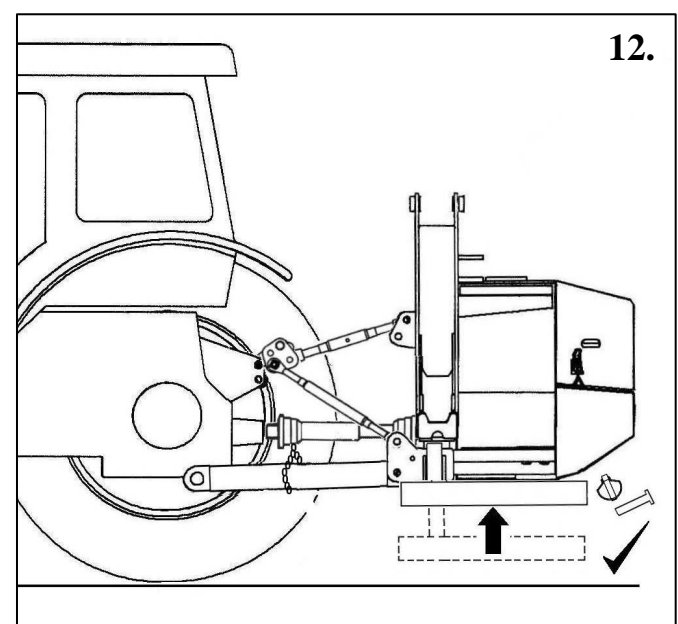
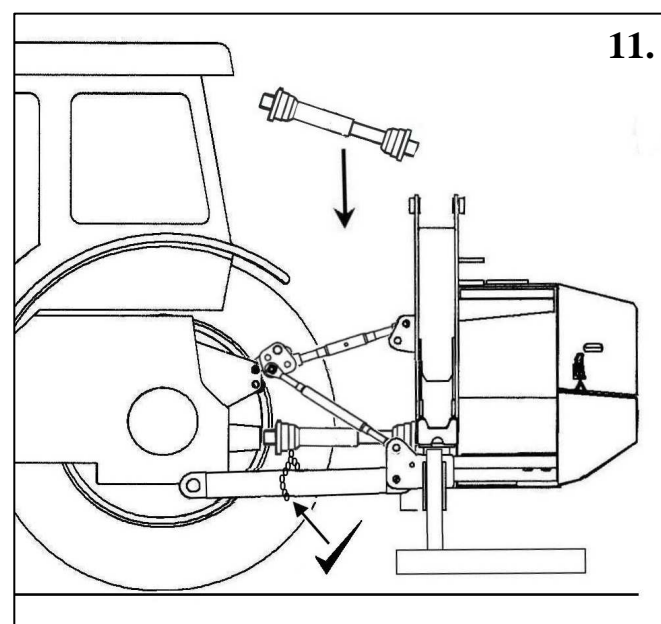
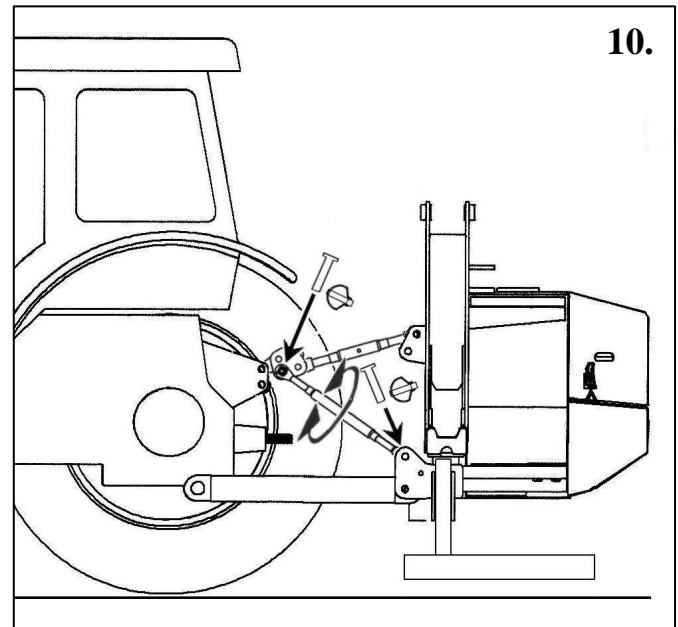
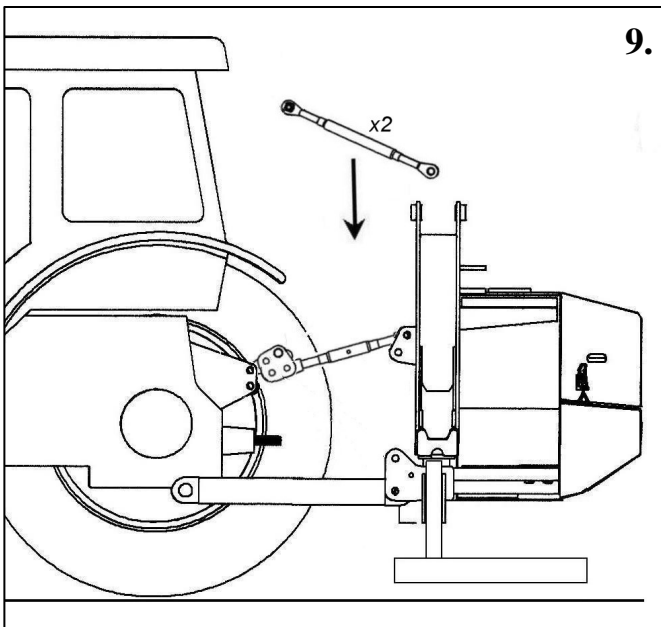
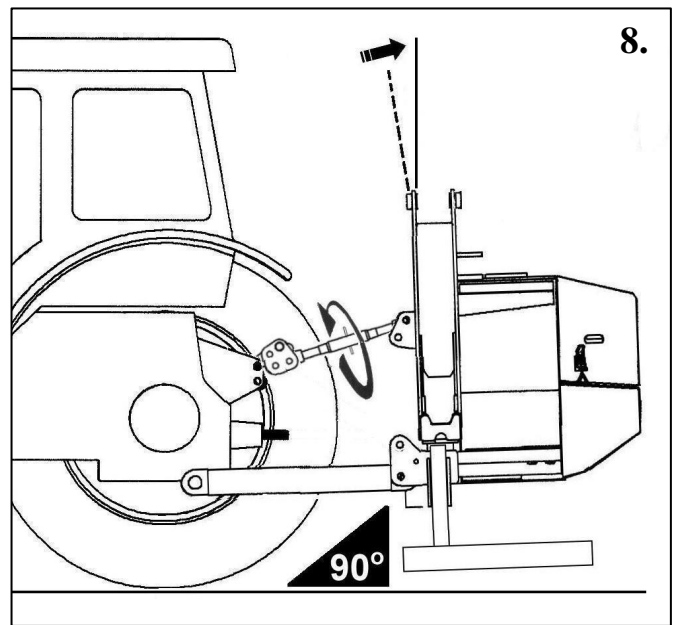
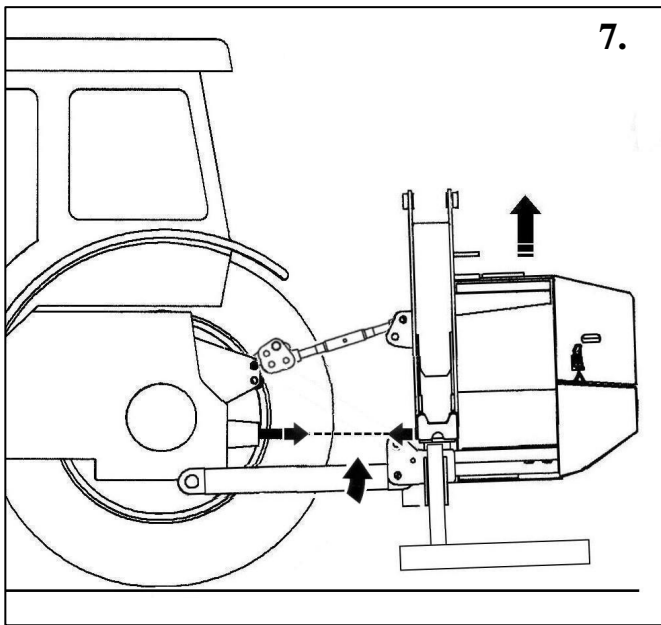

Spearhead Excel 470

Flail Trimmer – Operation Information

The vehicle driver should be conversant with all tractor controls and capabilities.

It is always advisable for the tractor driver to practice the controls and operations of the Flail Trimmer, in a safe open location away from potential hazards, prior to setting off into work.

The speed of operation of Trimming will depend on the size, quantity, and type of growth to be cut. A slow speed to suit conditions should be selected, ensuring that engine speed gives a P.T.O speed of 540 Max. R.P.M for general use - *this 540 Max. R.P.M (PTO) is recommended for best trimming results and performance, variation from this recommended R.P.M should be kept to a minimum and never at any time should PTO R.P.M exceed 540 R.P.M.*

Rotor Rotation Direction

Depending on the type of hedge to be cut, an option of rotation direction is offered.

The 'upward' cut is recommended for trimming grass, light growth such as one/two year's growth.

DOWNWARD CUTTING IS NOT RECOMMENDED - and should only be considered for really heavy, large diameter, growth cutting - even then, it is important that down cutting is kept to the minimum, very short periods, only.

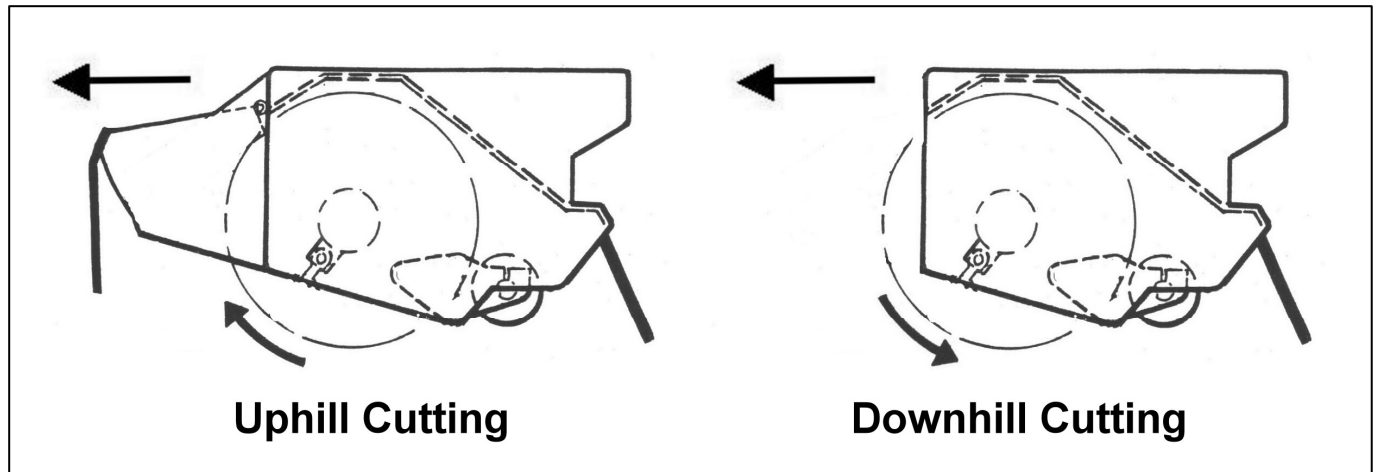

DANGER - IMPORTANT

In heavy conditions when cutting large diameter growth with front cowling removed, the rotor **MUST ALWAYS CUT DOWNWARDS AT FRONT.**
At no time should the rotor be cutting upwards with the front cowling removed.

Spearhead Excel 470

DANGER VERY IMPORTANT

It is very important that motor spool and motor spool control lever works in one direction only - From centre (OFF) position to selected (ON) 'rotor cut' direction position – permitting the rotor one direction of cut and the 'OFF' setting only.

This eliminates the chance of going from 'cut-up' to 'cut-down' in one movement of controls and blowing the system. Only by altering LOCK-LEVER setting can direction of control lever be changed.

WARNING

DANGER - NEVER CHANGE DIRECTION OF ROTOR CUT WHILST ROTOR IS STILL TURNING

DANGER - ALWAYS ALLOW ROTOR TO STOP SPINNING COMPLETELY BEFORE CHANGING CUT ROTATION DIRECTION

Rotor Control Operation

The rotor control lever operates the rotor 'on' and 'off' function for both uphill and downhill cutting - the specific cutting direction is dictated by the position of the locking latch on the front of the cable control head unit, with the latch in the vertical position the lever can be moved from its centre 'off' position to the forwards 'on' position for uphill cutting direction. With the latch in the horizontal position the lever can be moved from its centre 'off' position to the backwards 'on' position for downhill cutting direction. The rotor is off when the control lever is in the central position – see illustration below.

WARNING: When switching off a rotor it will continue to 'freewheel' before stopping - in some cases this can be up to 40 seconds or more. Never approach a machine whilst the rotor is running.

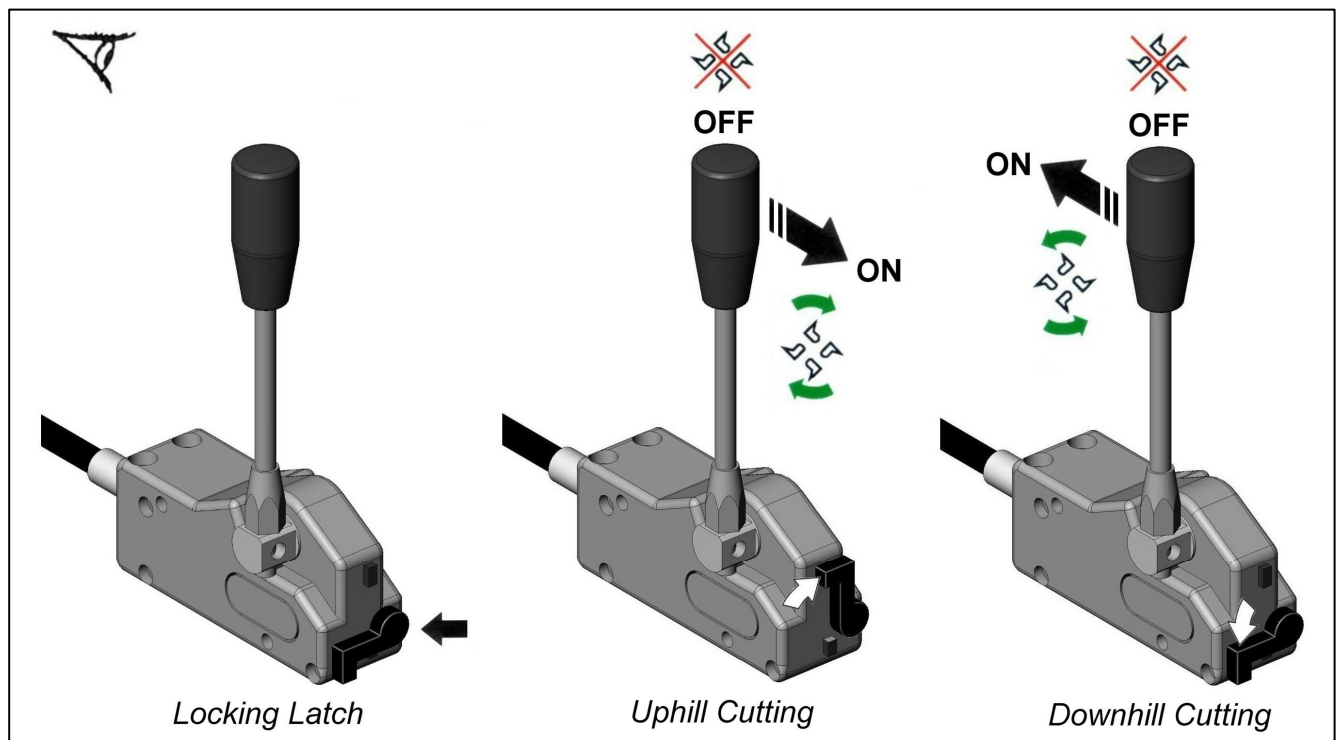

ROTOR CUT DIRECTION MUST NEVER BE CHANGED IN ONE MOVEMENT

Spearhead Excel 470

Cable Controls

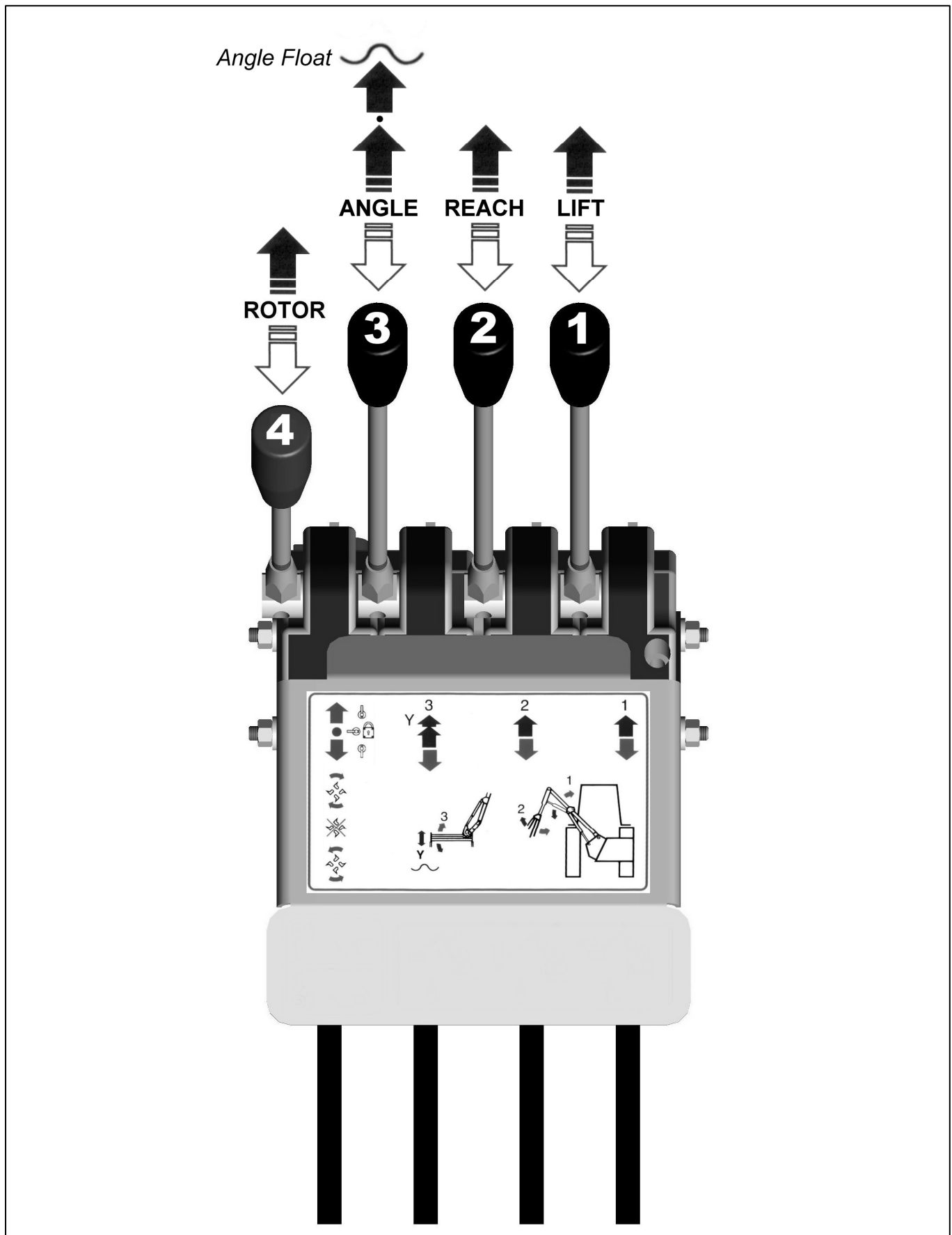

Spearhead Excel 470

Cable Controls – Lever Functions

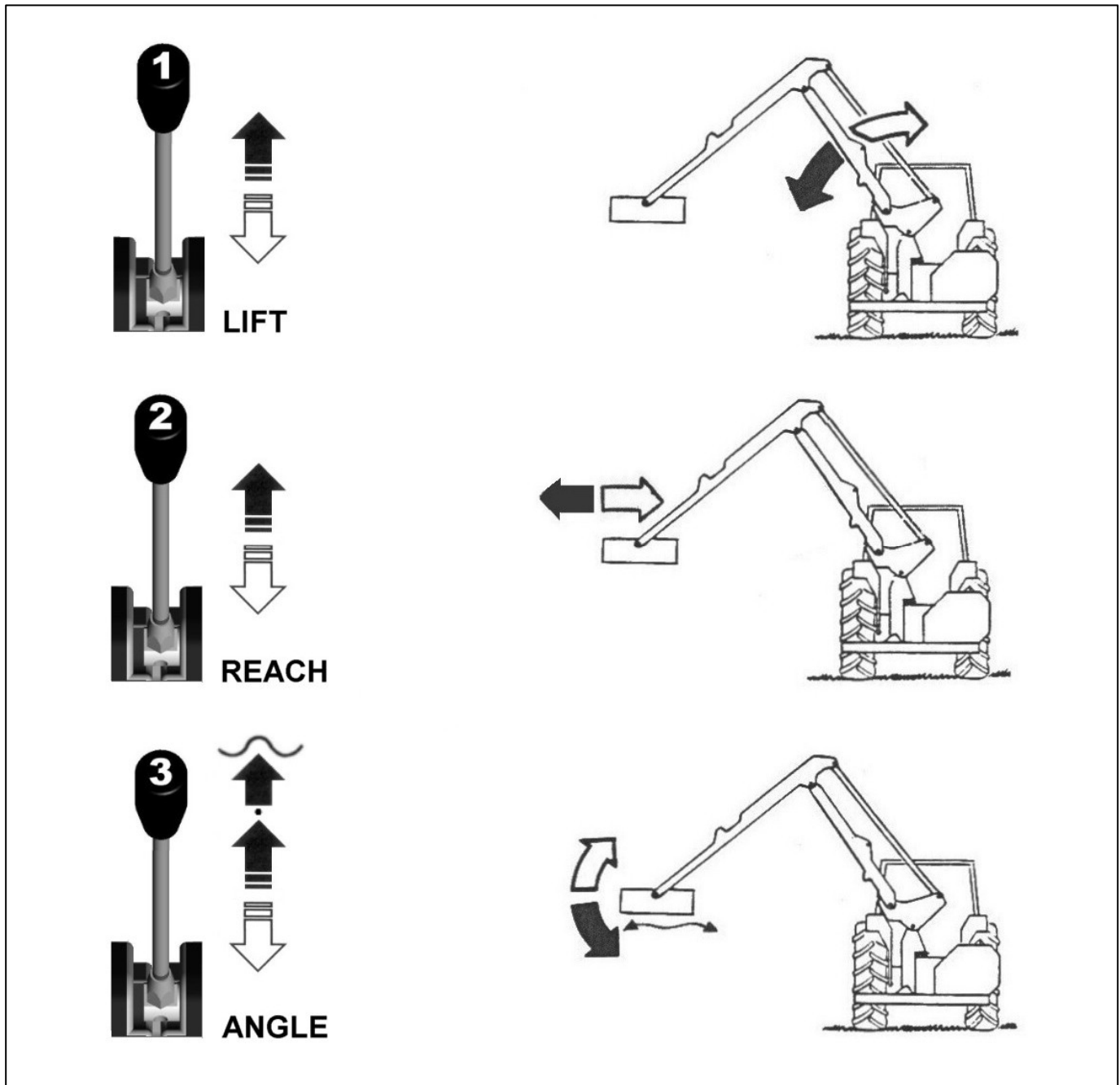

Spearhead Excel 470

Hydraulic Controls – Cutting Position

The cutting head must at all times be lowered gently into the cutting position. Never 'drop' a flail head into a hedge at speed. When cutting at ground level (grass etc.) the head must be lowered gently to give a slight contact pressure of roller to ground.

WARNING:

Ensure flail head does not come into contact with obstacles such as rocks, stones, stumps etc. Keep rotor away and free from wire, as to entangle wire in a rotor is both dangerous and costly. *Should large obstacles be encountered or wire become entangled in the rotor **stop immediately** and reset or clear before continuing.*

DANGER WARNING

Always stop machine, switch off engine and pocket the key before attempting to remove any items that foul the flail head.

Normal obstacles and level variations should be overcome by the operator slowing 'forward motion' and raising/lowering the booms of trimmers to suit.

Cutting Head

The cutting head rotor has been balanced prior to fitting; this will ensure a vibration free cutting unit.

Should the rotor become blocked for any reason, hit an obstacle, loose a blade or blades, the rotor may be put into a state of unbalance. This will result in vibration from the rotor being transmitted through the head. Should this happen **stop immediately**, as to continue may have serious consequences.

Once stopped clean rotor and check for loss of blades and bolts, replace as required. As a result of hitting solid objects with serious force the rotor can be bent, this will obviously cause vibrations. In such cases the only answer will be to get the rotor repaired/rebalanced or replaced.

Keep the cutting blades VERY SHARP: the flail head should be inspected daily. Bolts and nuts holding flails to rotor should be checked frequently and kept **tight**. Missing or broken flails should be replaced immediately, as the imbalance will rapidly harm bearings and structure. When a flail is renewed its opposing flail (or pair if using Back to Back flails) should be renewed also in order to maintain balance.

Check 'vee' belt tension on cutter head daily: a load of 5Kgs (10 lbs.) should give a deflection of 9mm at these pulley centres. Access to the belts is by removing the guard panel on the side of the drive end. Tension is adjusted by first slackening the bolts mounting the motor (*nuts are held from turning on the inside*). The nuts on the threaded adjuster can now be turned to give the required tension and then re-tightened and the motor mounting bolts then tightened also.

Spearhead Excel 470

Transportation

For transport the machine should be 'folded' into a position that is as compact as possible within the confines of the tractor width. The cutting head should be placed into the vertical position with the flails outwards ensuring sufficient clearance of the tractor wheel to avoid possible contact or fouling during transportation.

WARNING

**Never transport a machine with the Booms open -
Ensure Booms are in contact with each other at all times.**

Removing The Machine From The Tractor

Select a good clear, level and firm site on which to detach and store the machine.

IMPORTANT

Use the hydraulics to lower the head onto the ground horizontally (*as if you were cutting grass*).

- Disengage the PTO drive.
- STOP THE TRACTOR ENGINE.
- Lower stand legs from their stowed position and place into the 'down' position – fit pins and secure with the lynch pins provided.
- LINK TYPE STABILIZER: Remove lynch pins from the stabiliser locating pins, and remove pins. It may be necessary to slightly raise three-point linkage to 'free' pins, for removal.
- CHAIN TYPE STABILIZER: Raise machine until chain becomes slack, remove chain from locking slots in lower stabilizer plates.
- Lower hedge trimmer so stand legs are on the floor, by means of lowering tractor three-point linkage. (*Top link may have to be adjusted to ensure trimmer is upright and safe*).
- When you are sure that trimmer is properly settled and safe on its stands, operate boom '1' lever to release hydraulic pressure from ram.
- Disconnect controls from tractor cab and stow neatly on the machine clear of the ground protected from the elements.
- Disconnect Power Take off shaft and anti-spin chains (*tractor end*).
- Remove lynch pins from lower lift pins and remove pins from linkage - tractor linkage arms are now free of the machine.
- Draw tractor slowly away - Many operators stop about 300mm (12") away to double-check that tractor and machine have completely separated and that no connections or couplings remain connected.

Safety screens can now be removed if so desired.

- Replace location pins back through arms of stabiliser assembly and secure in position with lynch pins.
- Re-connect top link bar assembly back onto stabiliser with pin and lynch pin provided.
- Replace lower linkage pins back into relevant positions on mounting frame and secure with lynch pins.
- Ensure tractor top link pin is replaced and secured with lynch pin.

Spearhead Excel 470

Maintenance

OIL FILTER CHANGE

Oil filter should be replaced initially after the first 50 hours and every 250 hours thereafter.

HYDRAULIC PUMP - GEARBOX

Gearbox oil level should be checked every 500 hours and topped up if required. Oil capacity for both Standard and Hi-Power Gearboxes is **0.5 Litres**.

Standard Hydraulic Gearbox use **S.A.E EP 90** oil - always ensure the same grade of oil is used for 'topping up' when required.

Hi-power Hydraulic Gearbox (Hi-ton) use **universal oil** - always ensure the same grade of oil is used for 'topping up' when required.

ROUTINE MAINTENANCE & LAYING UP

Daily Maintenance

- Check oil level in main system oil tank.
- Grease pivot points regularly.
- Check cutting blade sharpness – always keep the cutting blades very sharp.
- Check all machine and safety guarding is in place and in good condition – replace or repair if required. **Never operate a machine with missing or damaged guarding.**
- Check hoses and connections for wear damage or leaks and replace immediately if required. **Never check for hydraulic leaks with your hand – use a piece of card.**

Weekly Maintenance

- Check all hydraulic fittings and hoses.
- Check 'vee' belts tension on cutter head drive.

Laying Up Maintenance

- Clean the machine and note any damage or repairs needed - arrange for spares and/or repairs as required in preparation for next season.
- Fully lubricate the machine totally.
- Store machine in a safe dry location - ideally in an 'undercover' location.
- Check 'vee' belts tension on cutter head drive.

A full inspection to all components of your machine should be made prior to starting a new season's work after a period of 'laying up'.

The Spearhead Warranty

Spearhead warrants that the Spearhead machine referred to in the Warranty Registration Form will be free from defects in materials and workmanship for a period of 12 months from the date of sale. This warranty does not affect your statutory rights, but merely adds to them. Should you have a problem within 12 months from the date of sale please contact your original Spearhead dealer, or Spearhead's Service Department. Any part found to be defective during this period would be replaced or repaired, at Spearhead's discretion, by the dealer or a Spearhead Service Engineer.

Spearhead Warranty Conditions

1. The Warranty Registration Form must be completed and returned to Spearhead within 30 days of the date of sale.
2. This warranty does not cover defects arising from fair wear and tear, willful damage, negligence, misuse, abnormal working conditions, use in competition, failure to follow Spearhead's instructions (oral or written, including all instructions and recommendation made in the Operator's Manual) or alteration or repair of the machinery without Spearhead's approval.
3. The machinery must have been serviced in accordance with the Operator's Manual.
4. This warranty does not cover claims in respect of wearing parts such as blades, flails, paintwork, tyres, belts, hydraulic hoses, bearings, bushes, linkage pins, top links, ball ends unless there is a manufacturing or material defect or the cost of normal servicing items such as oils and lubricants.
5. This warranty does not cover any expenses or losses incurred whilst the machinery is out of use for warranty repairs or parts replacement.
6. This warranty does not extend to parts, materials or equipment not manufactured by Spearhead, for which the Buyer shall only be entitled to the benefit of any such warranty or guarantee given by the manufacturer to Spearhead. Only genuine Spearhead replacement parts will be allowable for warranty claims.
7. All parts replaced by Spearhead under warranty become the property of Spearhead and must be returned to Spearhead if Spearhead so request. Such parts may only be disposed of after a warranty claim has been accepted and processed by Spearhead.
8. Spearhead is not liable under this warranty for any repairs carried out without Spearhead's written consent or without Spearhead being afforded a reasonable opportunity to inspect the machinery the subject of the warranty claim. Spearhead's written consent must, therefore, be obtained before any repairs are carried out or parts replaced. Use of non-Spearhead parts automatically invalidates the Spearhead Warranty. Failed components must not be dismantled except as specifically authorised by Spearhead and dismantling of any components without authorisation from Spearhead will invalidate this warranty.

9. All warranty claims must be submitted to Spearhead on Spearhead Warranty Claim Forms within 30 days of completion of warranty work.

Using the machine implies the knowledge and acceptance of these instructions and the limitations contained in this Manual

Extended Warranty (UK only)

As an extension to the 12-month warranty set out above, Spearhead will provide an additional 12 month warranty cover subject to the Spearhead Warranty Conditions above and the Extended Warranty Conditions below.

Extended Warranty Conditions

1. The extended warranty applies to hydraulic pumps, motors, valves and gearboxes only. It does not apply to other parts, to consumables such as lubricants, seals or filters or to labor charges.
2. The machinery must have had an annual service carried out by an Authorised Spearhead Dealer or a Spearhead Service Engineer within 1 month of the first anniversary of the date of sale.
3. The extended warranty does not cover costs of transportation of the machinery to or from the dealer or Spearhead or the call out costs or traveling expenses of on-site visits.

Transfer of Warranty

The Spearhead warranty may be transferred to a subsequent owner of the machinery (for use within the UK) for the balance of the warranty period subject to all of the warranty conditions and provided that the Change of Owner form is completed and sent to Spearhead within 14 days of change of ownership.

Spearhead reserves the right to make alterations and improvements to any machinery without notification and without obligation to do so.

Spearhead Machinery Ltd
Green View
Salford Priors
Evesham
Worcestershire
WR11 8SW

Tel: 01789 491860

Fax: 01789 778683

www.spearheadmachinery.com
enquiries@spearheadmachinery.com