

# Spearhead

## TWIGA PRO Reach Mower 560/650T/700T/800T 600VFR/650VFR



Edition 1.4 – April 2014  
PART No. 8999049

**HANDBOOK**

# Spearhead TWIGA PRO

---

## CE Declaration of Conformity, Conforming to EU Machinery Directive 2006/42/EC

We, Spearhead Machinery Ltd, Green View, Salford Priors,  
Evesham, Worcestershire, WR11 8SW hereby declare that:

**Product** .....

**Product Code**.....

**Serial No**.....

**Type**.....

Manufactured by: Alamo Manufacturing Services (UK) Limited, Station Road,  
Salford Priors, Evesham, Worcestershire, WR11 8SW

Complies with the required provisions of the Machinery Directive 2006/42/EC.  
The Machinery Directive is supported by the following harmonized standards:

- BS EN ISO 14121-1 (2007) Safety of Machinery – Risk Assessment, Part 1: Principles Part 2: Practical Guide and Examples of Methods.
- BS EN ISO 12100-1 (2010) Safety of Machinery – Part 1: Basic Terminology and Methodology Part 2: Technical Principles.
- BS EN 349 (1993) + A1 (2008) Safety of Machinery – Minimum Distances to avoid the Entrapment of Human Body Parts.
- BS EN 953 (1998) Safety of Machinery – Guards General Requirements for the Design and Construction of Fixed and Movable Guards.
- BS EN 982 (1996) + A1 (2008) Safety Requirements for Fluid Power Systems and their Components. Hydraulics.

The EC Declaration only applies if the machine stated above is used in  
accordance with the operating instructions.

**Signed**



(On behalf of Spearhead Machinery Ltd)

**Status**

General Manager

**Date**

01/04/2014

## IMPORTANT VERIFICATION OF WARRANTY REGISTRATION



### DEALER WARRANTY INFORMATION & REGISTRATION VERIFICATION

It is imperative that the selling dealer registers this machine with Spearhead Machinery Limited before delivery to the end user – failure to do so may affect the validity of the machine warranty.

To register machines go to the Spearhead Machinery Limited web site at [www.spearheadmachinery.com](http://www.spearheadmachinery.com), log onto 'Dealer Inside' and select the 'Machine Registration button' which can be found in the Service Section of the site. Confirm to the customer that the machine has been registered in the section below.

Should you experience any problems registering a machine in this manner please contact the Spearhead Service Department on 01789 491867.

### Registration Verification

Dealer Name: .....
Dealer Address: .....
Customer Name: .....
Date of Warranty Registration: ...../...../..... Dealer Signature: .....

### NOTE TO CUSTOMER / OWNER

*Please ensure that the above section has been completed and signed by the selling dealer to verify that your machine has been registered with Spearhead Machinery Limited.*

**IMPORTANT:** During the initial 'bedding in' period of a new machine it is the customer's responsibility to regularly inspect all nuts, bolts and hose connections for tightness and re-tighten if required. New hydraulic connections occasionally weep small amounts of oil as the seals and joints settle in – where this occurs it can be cured by re-tightening the connection – *refer to torque settings chart below*. The tasks stated above should be performed on an hourly basis during the first day of work and at least daily thereafter as part of the machines general maintenance procedure.

# Spearhead TWIGA PRO

**CAUTION: DO NOT OVER TORQUE HYDRAULIC FITTINGS AND HOSES**

## TORQUE SETTINGS FOR HYDRAULIC FITTINGS

HYDRAULIC HOSE ENDS		
BSP	Setting	Metric
1/4"	18 Nm	19 mm
3/8"	31 Nm	22 mm
1/2"	49 Nm	27 mm
5/8"	60 Nm	30 mm
3/4"	80 Nm	32 mm
1"	125 Nm	41 mm
1.1/4"	190 Nm	50 mm
1.1/2"	250 Nm	55 mm
2"	420 Nm	70 mm

PORT ADAPTORS WITH BONDED SEALS		
BSP	Setting	Metric
1/4"	34 Nm	19 mm
3/8"	47 Nm	22 mm
1/2"	102 Nm	27 mm
5/8"	122 Nm	30 mm
3/4"	149 Nm	32 mm
1"	203 Nm	41 mm
1.1/4"	305 Nm	50 mm
1.1/2"	305 Nm	55 mm
2"	400 Nm	70 mm

## WARRANTY POLICY

### WARRANTY REGISTRATION

All machines must be registered, by the selling dealer with Spearhead Machinery Ltd, before delivery to the end user. On receipt of the goods it is the buyer's responsibility to check that the Verification of Warranty Registration in the Operator's Manual has been completed by the selling dealer.

#### 1. LIMITED WARRANTIES

- 1.01. All machines supplied by Spearhead Machinery Limited are warranted to be free from defects in material and workmanship from the date of sale to the original purchaser for a period of 12 months, unless a different period is specified.
- 1.02. All spare parts supplied by Spearhead Machinery Limited are warranted to be free from defects in material and workmanship from the date of sale to the original purchaser for a period of 6 months.
- 1.03. The manufacturer will replace or repair for the purchaser any part or parts found, upon examination at its factory, to be defective under normal use and service due to defects in material or workmanship. Returned parts must be complete and unexamined.
- 1.04. This warranty does not apply to any part of the goods, which has been subjected to improper or abnormal use, negligence, alteration, modification, fitment of non-genuine parts, accident damage, or damage resulting from contact with overhead power lines, damage caused by foreign objects (e.g. stones, iron, material other than vegetation), failure due to lack of maintenance, use of incorrect oil or lubricants, contamination of the oil, or which has served its normal life. This warranty does not apply to any expendable items such as blades, flails, bushes, belts, flap kits, skids, shields, guards, wear pads or pneumatic tyres.

# Spearhead TWIGA PRO

---

- 1.05. Temporary repairs and consequential loss - i.e. oil, downtime and associated parts are specifically excluded from the warranty.
- 1.06. Warranty on hoses is limited to 12 months and does not include hoses which have suffered external damage. Only complete hoses may be returned under warranty, any which have been cut or repaired will be rejected.
- 1.07. Machines must be repaired immediately a problem arises. Continued use of the machine after a problem has occurred can result in further component failures, for which Spearhead Machinery Ltd cannot be held liable, and may have safety implications.
- 1.08. Except as provided herein, no employee, agent, dealer or other person is authorised to give any warranties of any nature on behalf of Spearhead Machinery Ltd.
- 1.09. For machine warranty periods in excess of 12 months the following additional exclusions shall apply:
- 1.09.1. Hoses, external seals, exposed pipes and hydraulic tank breathers.
  - 1.09.2. Filters
  - 1.09.3. Rubber mountings
  - 1.09.4. External electric wiring.
  - 1.09.5. Labour and mileage costs.
- 1.10. All service work, particularly filter changes, must be carried out in accordance with the manufacturer's service schedule. Failure to comply will invalidate the warranty. In the event of a claim, proof of the service work being carried out may be required.

***NB Warranty cover will be invalid if any non-genuine parts have been fitted or used. Use of non-genuine parts may seriously affect the machine's performance and safety. Spearhead Machinery Ltd cannot be held responsible for any failures or safety implications that arise due to the use of non-genuine parts.***

## 2. REMEDIES AND PROCEDURES

- 2.01. The warranty is not effective unless the Selling Dealer registers the machine, via the Spearhead Machinery web site and confirms the registration to the purchaser by completing the confirmation form in the operator's manual.
- 2.02. Any fault must be reported to an authorised Spearhead Machinery dealer as soon as it occurs. Continued use of a machine, after a fault has occurred, can result in further component failure for which Spearhead Machinery Ltd cannot be held liable.
- 2.03. Repairs should be undertaken within two days of the failure. Claims submitted for repairs undertaken more than 2 weeks after a failure has occurred, or 2 days

# Spearhead TWIGA PRO

---

after the parts were supplied will be rejected, unless the delay has been authorised by Spearhead Machinery Ltd.

2.04. All claims must be submitted, by an authorised Spearhead Machinery Service Dealer, within 30 days of the date of repair.

2.05. Following examination of the claim and parts the manufacturer will pay, at their discretion, for any valid claim the cost of any parts and an appropriate labour allowance if applicable.

2.06. The submission of a claim is not a guarantee of payment.

2.07. Any decision reached by Spearhead Machinery Ltd is final.

### **3. LIMITATION OF LIABILITY**

3.01. The manufacturer disclaims any express (except as set forth herein) and implied warranties with respect to the goods including, but not limited to, merchantability and fitness for a particular purpose.

3.02. The manufacturer makes no warranty as to the design, capability, capacity or suitability for use of the goods.

3.03. Except as provided herein, the manufacturer shall have no liability or responsibility to the purchaser or any other person or entity with respect to any liability, loss, or damage caused or alleged to be caused directly or indirectly by the goods including, but not limited to, any indirect, special, consequential, or incidental damages resulting from the use or operation of the goods or any breach of this warranty. Notwithstanding the above limitations and warranties, the manufacturer's liability hereunder for damages incurred by the purchaser or others shall not exceed the price of the goods.

3.04. No action arising out of any claimed breach of this warranty or transactions under this warranty may be brought more than one (1) year after the cause of the action has occurred.

### **4. MISCELLANEOUS**

4.01. The manufacturer may waive compliance with any of the terms of this limited warranty, but no waiver of any terms shall be deemed to be a waiver of any other term.

4.02. If any provision of this limited warranty shall violate any applicable law and is held to be unenforceable, then the invalidity of such provision shall not invalidate any other provisions herein.

4.03. Applicable law may provide rights and benefits to the purchaser in addition to those provided herein.

# Spearhead TWIGA PRO

---

## Contents

### General Information

EC Declaration of conformity.....	1
Warranty.....	2
Introduction.....	8
Specification.....	9

### Safety

Safety Recommendation.....	10
Overhead Power Lines.....	12
Safety Decal.....	14
Warning Signs.....	14
Road Work Guidelines.....	14
Lighting Kits.....	15
Training.....	15
Tractor Requirements.....	15
Lifting Points.....	15

### Installing your Machine

Attaching your Machine to the Tractor – Using 3 Point Linkage.....	16
Attaching your Machine to the Tractor - Using Axle Mounting.....	20
Attaching your Machine to the Tractor - Using Integrated Axle Mounting.....	22
Running up your Machine.....	24
Removing from the Tractor.....	25
Hydraulic Proportional Controls - 2SV.....	26
Hydraulic Proportional PRO PILOT Controls - 3SV.....	27
Electric Proportional PRO PILOT Controls - 3SV.....	27
PRO PILOT Switch Box.....	28
Operation Warnings.....	29
Moving into Transport Position.....	30
Operation.....	32

### Options

Oil Cooler.....	34
Head Float.....	35
Arm Float.....	36
Debris Blower.....	37
Hydraulic Rear Roller.....	38
Autopilot.....	39
Quad Saw.....	44
Cutter Bar.....	47
Telescopic Arm.....	48
Variable Forward Reach.....	49

# Spearhead TWIGA PRO

---

## Service & Maintenance

Daily Grease Points.....	50
Torque Settings.....	51
Hydraulic Hoses.....	52
Oil Supply.....	53
Filtration Maintenance.....	53
Pin & Bushes.....	54
Storage.....	54
Regular Service Chart.....	55

## Diagnostics

Pump & Motor Failure Prevention.....	55
Trouble Shooting.....	56



# Spearhead TWIGA PRO

---

## Introduction

The TWIGA PRO is a very robust high capacity reach mower that is easy to operate and maintain. To ensure trouble-free operation this manual should be carefully studied.

The term Left and Right hand applies to the machine when coupled to the tractor and viewed from the rear, this also applies to the tractor.

## Important Note

The information contained in this manual is correct at the time of publication. However, in the course of constant development, changes in specification are inevitable. Should you find the information given in this book different to the Machine it relates to please contact the "After Sales Department" for advice.

Please ensure that this manual is handed to the operator before using the machine for the first time. The operator must fully understand the contents of this manual before using this machine.  
(If the machine is resold the Manual must be given to the new owner.)

# Spearhead TWIGA PRO

## Specification

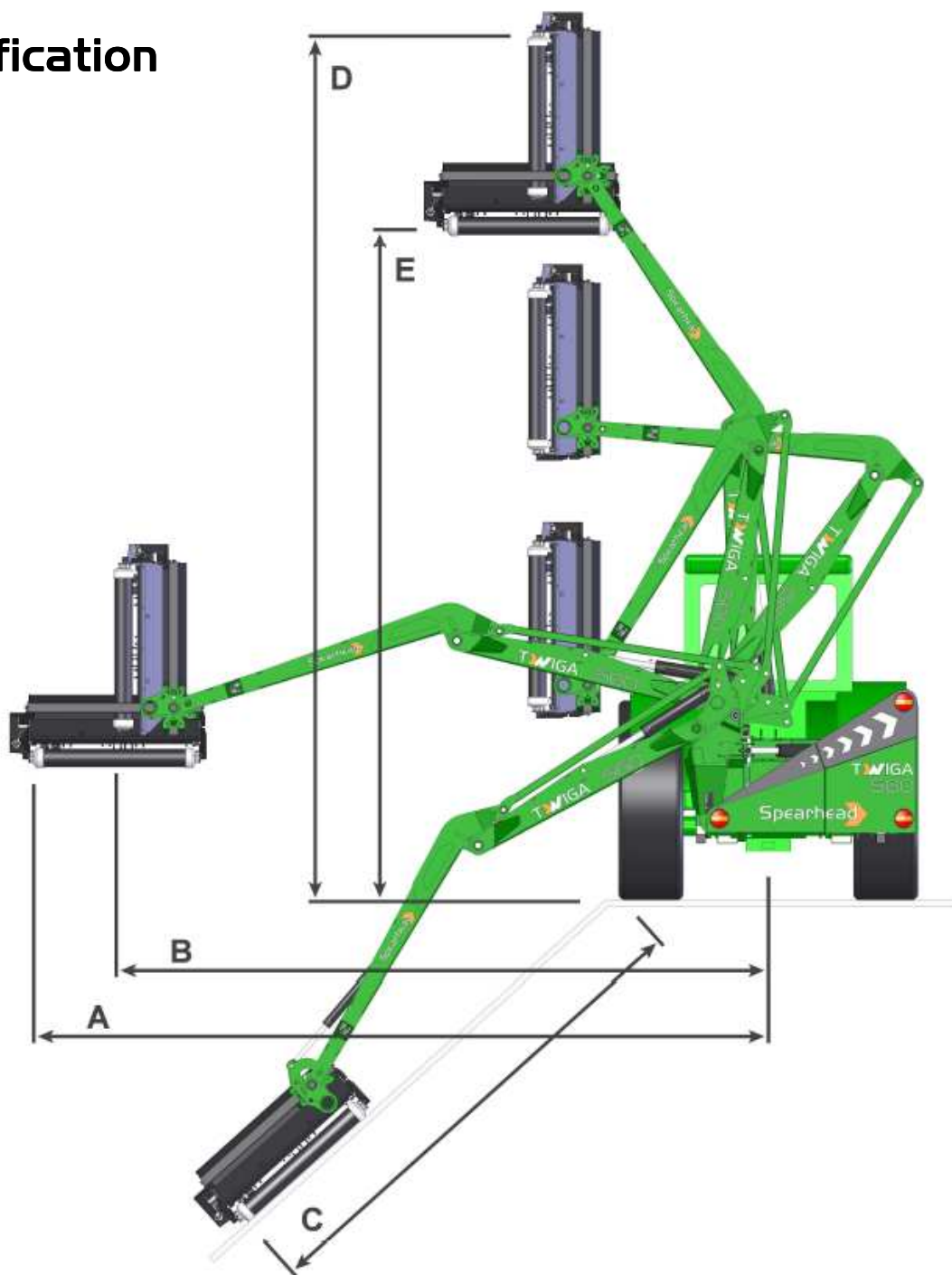

	560	650T	700T	800T	600VFR	650VFR
Weight inc. Oil (Kg)	1500	1650	1720	1850	1700	1750
Weight of head (Kg)	300	300	300	300	300	300
Tractor horse power	100-130	120-150	140-170	160-190	120-150	140-150
Min. tractor weight (Kg)	4500	5000	6000	6500	5000	6000
Oil tank capacity (ltr)	220	220	220	220	220	220
Reach A (m)	5.6	6.5	7.0	8.0	6.0	6.5
Reach B (m)	5.0	5.9	6.4	7.4	5.4	5.9
Reach C (m)	3.8	4.7	5.2	6.0	4.2	4.7
Reach D (m)	6.7	7.6	8.1	8.6	7.1	7.6
Reach E (m)	5.2	6.1	6.6	7.1	5.6	6.1

# Spearhead TWIGA PRO

---

## Safety Recommendations

Beware of the following Potential Dangers associated with the use of this machine:

- Becoming trapped when hitching or unhitching
- Tractor overbalancing when arm is extended
- Electrocution due to hitting overhead power lines
- Getting caught on rotating power take off (PTO)
- Being hit or caught by any moving part, e.g. belts, pulleys, arms, cutting head
- Being hit by flying debris or machine parts due to machine damage
- Machine overbalancing when not in use
- Injection of high pressure oil from damaged couplings or hydraulic hoses
- Accidents due to collision with other machines, or debris left on road

### Always

- Ensure the operator has read this handbook and has been trained to use the machine.
- Ensure all cab safety guards are in place and all tractor windows closed.
- Before leaving the tractor cab always ensure that the flail head is firmly on the ground, no weight is on the machine's hydraulics and the rotor has stopped spinning.
- Check that all guards are properly fitted and there are no damaged or loose parts. Particular attention should be given to the flails to ensure they are not damaged, cracked or missing.
- Inspect work area for wire, steel posts, large stones and other dangerous materials and remove before starting work.
- Beware of the danger of overhead power cables. The operator must be aware of the maximum height and reach of the machine when working under power cables. For more information contact the Health and Safety Executive or your local power company.
- Ensure that all warning labels are always visible and that they are not damaged, defaced or missing.
- Lower the head to the ground when parking up
- Fit locking pins to slew and height before transport and before unhitching when applicable.
- Wear ear defenders if operating without a quiet cab or with the cab windows open.
- Ensure tractor guards are fitted correctly and are undamaged
- Work at a safe speed, taking into account terrain, passing vehicles and obstacles
- Ensure that the tractor meets the minimum weight recommendations of the machine manufacturer and that ballast is used if necessary
- Check that machine fittings and couplings are in good condition

# Spearhead TWIGA PRO

---

- Follow the manufacturer's instructions for attachment and removal of machine from the tractor are warning signs to alert others to the type of machine working in the vicinity. Signs should be placed at both ends of the work site and should be in accordance with Department of Transport recommendations.
- Ensure flails are of the type recommended by the manufacturer, are securely fitted and are undamaged.
- Ensure hydraulic pipes are correctly routed to avoid damage from chafing, stretching, pinching or kinking.
- Disengage the machine, stop the engine and remove the key before leaving the tractor cab for any reason.
- Clean up any debris left at the work site.
- Ensure that when you remove the machine from the tractor it is secured in a safe position using the stands provided.

## NEVER

- Never operate the machine with other people present, as it is possible for debris, including stones, to be discharged from the front and rear of the flail head.
- Never operate the machine until you have read and understood the relevant Handbook and are familiar with the controls.
- Never use a machine that is poorly maintained or has guards that are damaged or missing
- Never allow an inexperienced person to operate the machine without supervision.
- Never use or fit a machine onto a tractor if it doesn't meet the manufacturer's specification.
- Never use a machine if the hydraulic system shows signs of damage.
- Never attempt to detect a hydraulic leak with your hand, use a piece of card.
- Never allow children to play on or around the machine at any time.
- Never attempt any maintenance or adjustment without first disengaging the PTO, lowering the head to the ground, stopping the tractor engine and applying the tractor parking brake.
- Never leave the cab without removing the ignition key.
- Never operate the tractor or any controls from any position other than from the driving seat.
- Never stop the engine with the PTO engaged.
- Never operate with flails missing.
- Never operate PTO **above** recommended speed for your machine, 540 R.P.M. flail head, 150 R.P.M. cutter-bar.
- Never operate with wire around the rotor. Stop immediately.
- Never use the head at an angle, which may throw debris towards the cab.
- Never attempt to use the machine for any purpose other than that it was designed for.
- Never transport with the PTO engaged
- Never enter the working area of the machine (risk of injury!)
- Never transport with the controls live, always turn off electrical isolator switch (red) and disconnect supply.

# Spearhead TWIGA PRO

## Overhead Power Lines

It cannot be stressed enough the dangers involved when working in the vicinity of Overhead Power Lines (OHPLs). Some of our machines are capable of reach in excess of 8 metres (26'); they have the potential to well exceed, by possibly 3 metres (9' 9"), the lowest legal minimum height of 5.2 metres from the ground for 11,000 and 33,000 volt power lines.

Remember electrocution can occur without actually coming into contact with a power line as electricity can 'flashover' when machinery gets close to it.



**WARNING: All operators must read the following information and be aware of the risks and dangers involved when working in the vicinity of Overhead Power Lines (OHPLs).**

Wherever possible the safest option is always to avoid working in areas close to OHPLs.

Where unavoidable, all operators must perform a risk assessment and implement a safe procedure and system of work – see *following page for details*.

All operators should perform a risk assessment before operating the machine within 10m horizontal distance of any OHPLs.

### Minimum Heights for Overhead Power Lines

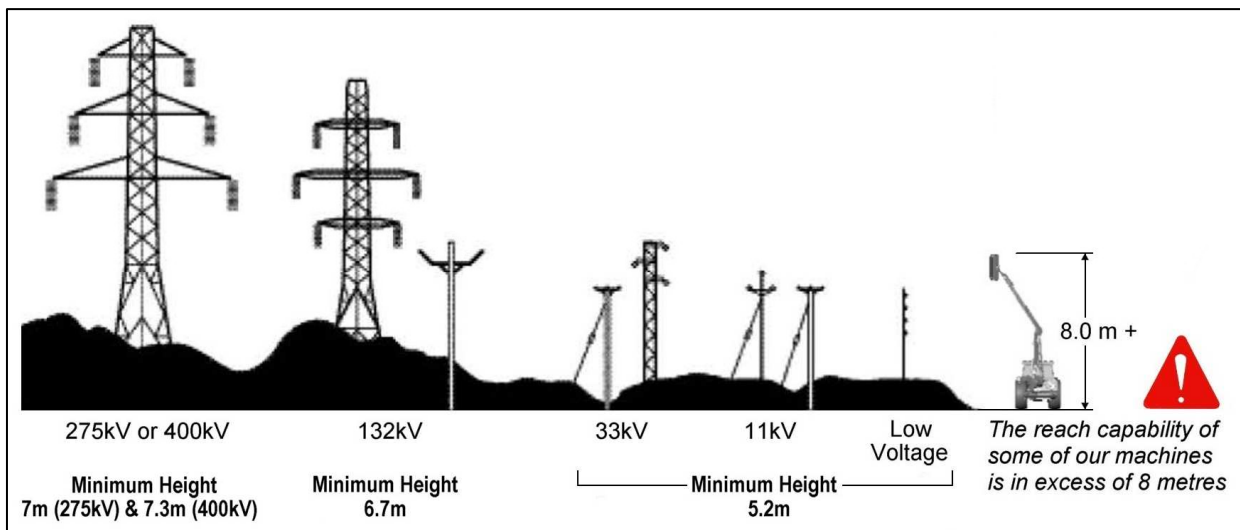

### Absolute Minimum Exclusion Zones for Specific Overhead Power Lines

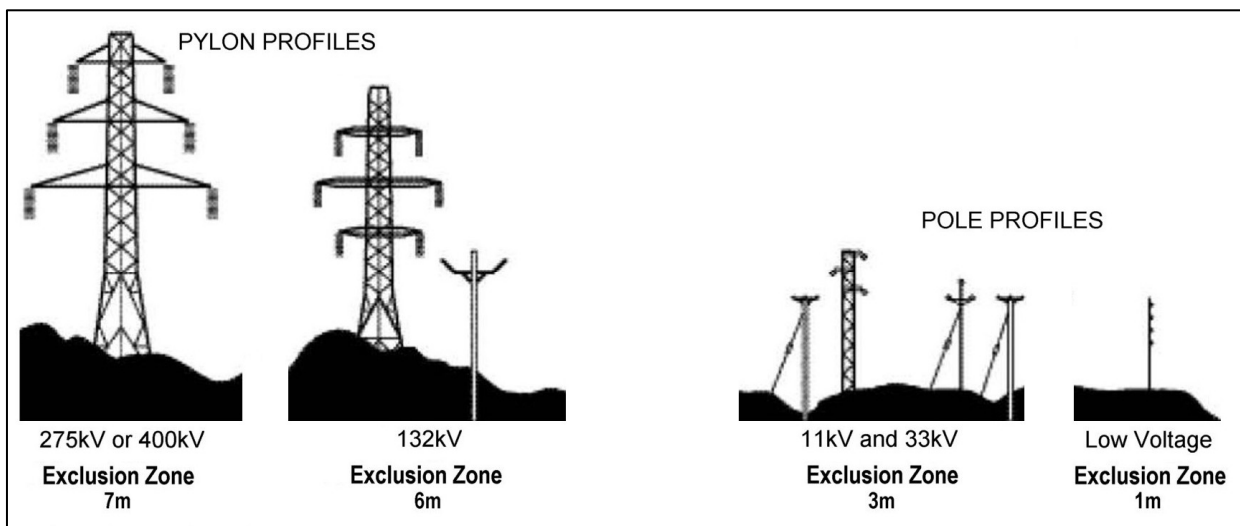

# Spearhead TWIGA PRO

## Definitions of Exclusion Zones

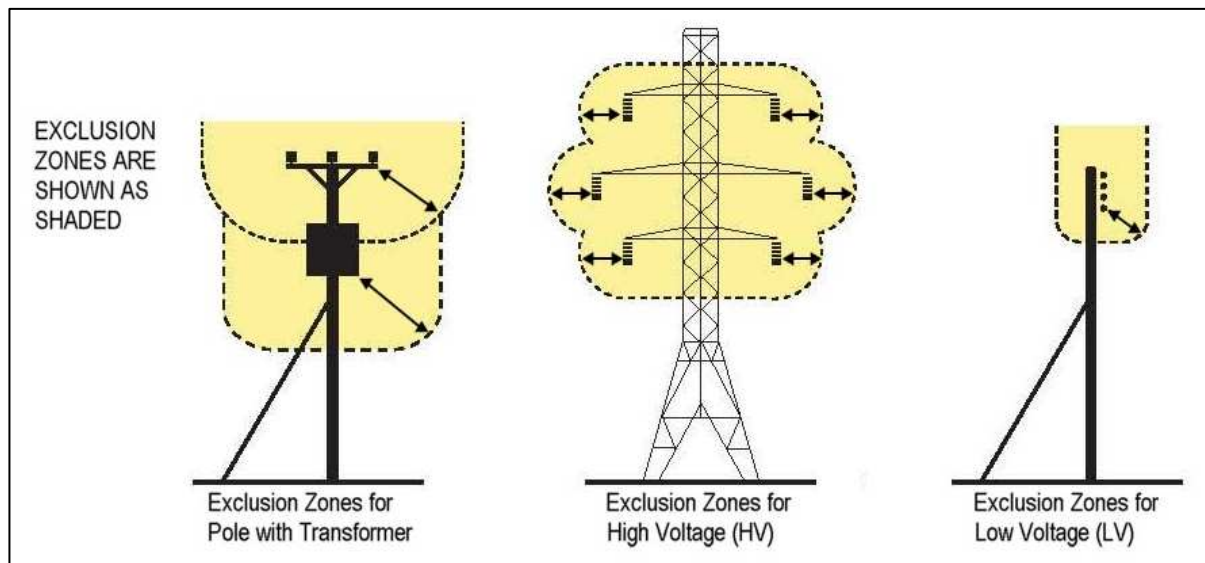

### Risk Assessment

Before starting to work near OHPLs you should always assess the risks. The following points should be observed;

**Know** the risks of contacting OHPLs and the risk of flashover.

**Find out** the maximum height and maximum vertical reach of your machine.

**Find out** the location and route of all Power Lines within the work area.

**Find out** the operating voltage of all Power Lines within the work area.

**Contact** the local Distribution Network Operator (DNO) who will be able to advise you on the operating voltage, safe minimum clearance distance for working and additional precautions required.

**Never** attempt operate the machine in an exclusion zones.

**Always** work with extreme caution and plan your work ahead to avoid high risk areas.

**If doubt exists** do not work in the area – never risk the safety of yourself or others.

### Emergency Action for Accidents Involving Electricity

- Never touch an overhead line - even if it has been brought down by machinery, or has fallen. Never assume lines are dead.
- When a machine is in contact with an overhead line, electrocution is possible if anyone touches both the machine and the ground. Stay in the machine and lower any raised parts in contact or drive the machine out of the lines if you can.
- If you need to get out to summon help or because of fire, jump out as far as you can without touching any wires or the machine - keep upright and away.
- Get the electricity company to disconnect the supply. Even if the line appears dead, do not touch it - automatic switching may reconnect the power.

Further information and leaflets on this and other agricultural safety subjects are available on the 'Health & Safety Executive' website at the following address: [www.hse.gov.uk/pubns/ajindex.htm](http://www.hse.gov.uk/pubns/ajindex.htm)

# Spearhead TWIGA PRO



## Safety Decal

### Warning

Check all bolts are tight every 8 hours.

### Warning

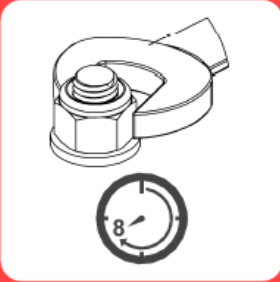
Beware of escaping fluid.

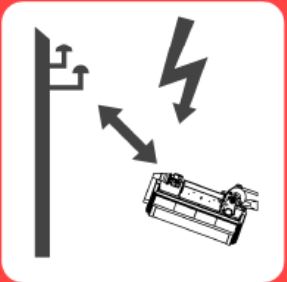
<p><b>GB</b> Carefully read the Operator's Manual before handling this machine. Observe instructions and safety rules when operating.</p> <p><b>D</b> Vor inbetriebnahme die Betriebsanleitung und Sicherheitshinweise lesen und beachten.</p> <p><b>F</b> Lire le livret d'entretien et les conseils de sécurité avant la mise en marche et en tenir compte pendant le fonctionnement.</p> <p><b>NL</b> Voor ingebruikname de bediening handleiding en veiligheids voorschriften lezen en in acht nemen.</p> <p><b>DK</b> Laes instruktionsbogen omhyggeligt før De sætter maskinen i gang. Vær opmærksom på instruktioner og sikkerhedshenvisninger under arbejdet!</p> <p><b>NO</b> Les instruksjonsboka grundig før maskinen tas i bruk. Følg in struksjonene og sikkerhets reglene under bruk!</p> <p><b>SE</b> Läs noga igenom instruktionsboken innan maskinen tas i bruk och följ alltid givna anvisningar och säkerhetsföreskrifter.</p> <p><b>FI</b> Lue käyttöohje huolellisesti ennenkuin alat käyttää konetta. Noudata käyttö- ja turvallisuusohjeita käytön aikana.</p> <p><b>PT</b> Leia cuidadosamente o manual de operações antes de iniciar o trabalho com a máquina. Verifique todas as instruções e regras de segurança quando estiver a trabalhar com a máquina.</p>	<b>D A N G E R</b>		
			

8770470

### Warning

Shut off engine and remove key before performing maintenance or repair work.

### Warning

Beware of overhead electrical power lines.

## Warning Signs

You are advised to display clear warning signs to indicate the type of machine when working in public places. The signs should be carefully placed at either end of the work site to give advanced warning of the hazard.

Contact your local Highways Authority or Department of Transport for more information.

## Roadwork Guidelines:

- On two-way roads, one set of signs should face the traffic in each direction.
- Work should be within 1 mile of the signs.
- Work only when visibility is good and at times of low risk, e.g. NOT during rush hour.
- Vehicles should show an amber flashing light.
- Vehicles should be conspicuously coloured.
- Debris should be removed from the road or path at regular intervals and the operator should wear high visibility clothing.
- Collect all warning signs promptly when the job is finished.

# Spearhead TWIGA PRO

---

## Training

It is the responsibility of the Spearhead dealer to provide instruction on the safe installation, operation and maintenance of the machine in the first instance. Further training is available from Spearhead Machinery Ltd on request, at cost.

## Tractor Requirements

- Check your Tractor size and minimum weight on the Specification table
- Before hitching, ensure position control is selected. Do not attempt to hitch in draft control.
- Set wheel width as wide as possible.
- Ballast weight is to be fitted within tractor manufacturer's recommended requirements
- Check chains and stabilisers must be in good working order to hold the machine firmly. Do not operate without checking chains and stabilisers are tight.
- Spearhead particularly recommend 'turn buckle' type stabiliser.
- Set linkage lift rods to an equal length
- Certain machines require a 12V fused electric supply that is controlled by the tractor's ignition key.
- Spearhead particularly recommend three point linkage of ball end type, we do not advise the use of claw type hitching. The quick release latches should be checked, if worn or insecure they may cause accidental damage or personal injury if the machine becomes detached.
- Ensure tractor link arms can be isolated from accidental lifting.

## Lighting Kits

For additional safety, rear mounted lighting kits are already fitted as standard. For more detailed information, contact the Department of Transport or your local Highways Authority.

## Pallet Fork Lifting Points

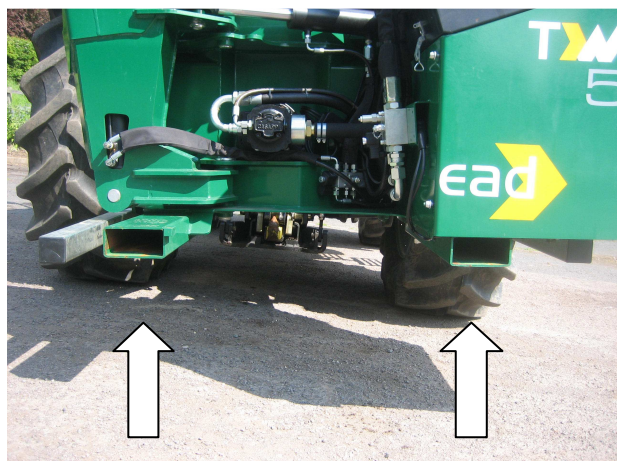



# Spearhead TWIGA PRO

## Attaching Machine To Tractor – 3 Point Linkage



1. Reverse tractor to machine and attach lower links.

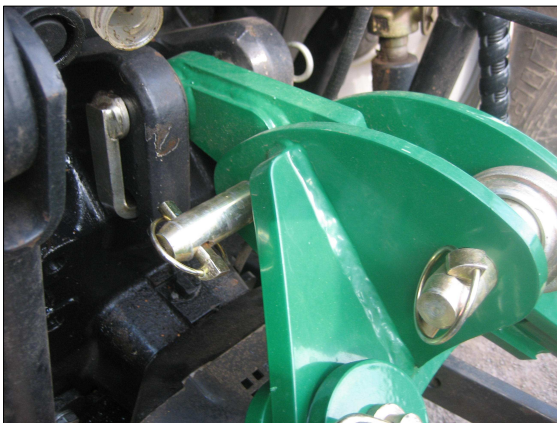

2. Fit stabiliser bracket into top link clevis and fit top link. The standard link comes with a Cat III hole plus a Cat III to Cat II reducing bush, a 28mm bracket is available on request.



3. Fit stabiliser tubes between A frame and stabiliser bracket. Ensure the tubes are free to slide, do fit locking pins.

# Spearhead TWIGA PRO



4. Raise machine to required height. Both P.T.O. shafts should be roughly in-line, an upward angle of up to  $17^\circ$  is acceptable to ensure adequate clearance.

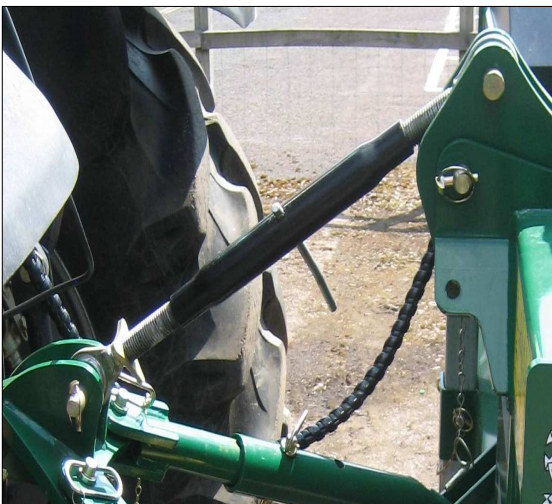

5. Adjust the top link so that the machine sits vertically.



6. Fit locking pins to stabiliser tubes, then the linkage can be lowered so that the weight of the machine is taken by the stabilisers. It is essential that both tubes are set to equal lengths, more than one attempt may be required to achieve the correct height as the machine settles on the stabilisers.

# Spearhead TWIGA PRO



7. It is recommended that the controls are mounted in-place of the seat armrest on the side of the cutting head. A pivoting bracket is supplied with every machine, if additional brackets are required contact your local dealer. A 12v/30Amp power supply will be required.

8. Ensure the engine is switched off and then fit the P.T.O. shaft. If fitting for the first time follow instructions below to cut P.T.O. to length. Ensure both sections are cut to equal lengths

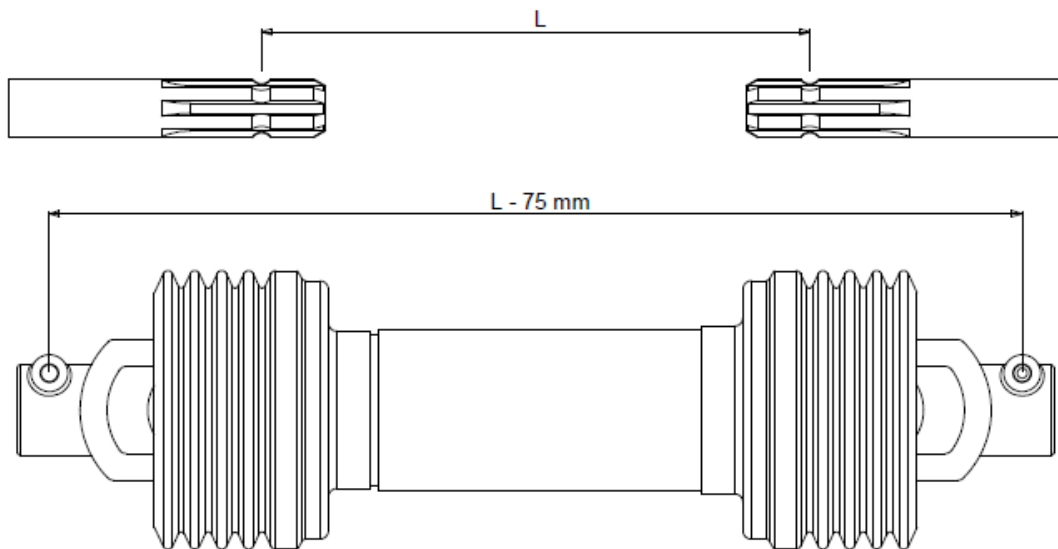

9. Remove slew locking pin.

# Spearhead TWIGA PRO



9. Raise leg stands to ensure they don't get damaged. Adjust check chains ensure the machine is secure and cannot swing from side to side.

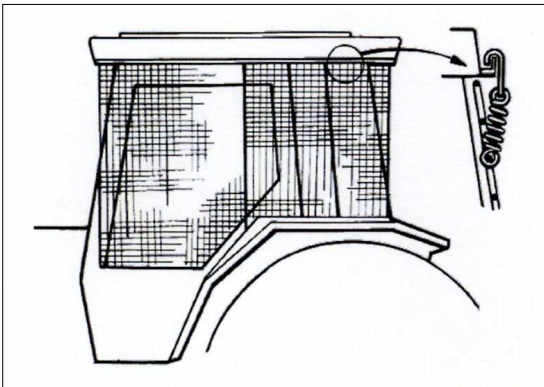

10. Use only tractors with safety glass. If windows are not laminated safety glass, polycarbonate glazing must be fitted between operator and cab meshing. Shape mesh to cover all windows that the driver will look through to view flail head in any operating position. Mesh can be retained by springs and clips supplied, but it is the operators responsibility to ensure guarding is firmly in place.

## Warning

Avoid raising the tractor linkage once the stabiliser bars are locked in place. Always lower the tractor linkage and allow all the weight to be carried by the stabiliser frame. Failure to observe this warning will result in bending the stabiliser bracket. When operating the machine's controls do so only when seated in the tractor cab. Do not allow anyone to stand on or amongst linkage for any reason

# Spearhead TWIGA PRO

## Attaching Machine To Tractor – Axle Mounting with Sub-Frame

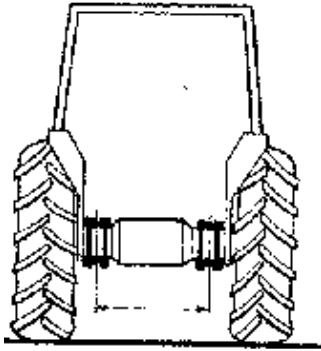

1. Mount axle brackets as instructed on separate fitting sheet specific to your tractor type.

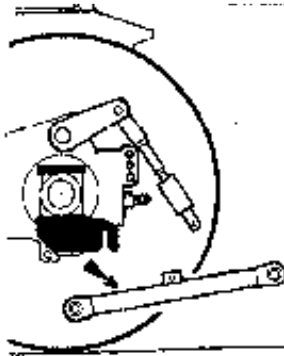

2. Detach tractor draft links.

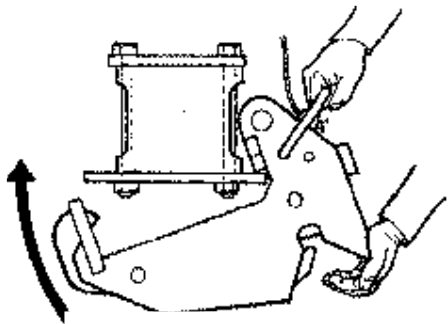

3. Fit lift-in hitch assembly

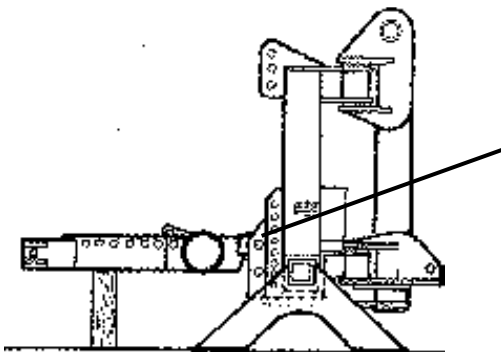

4. Assemble sub frame to suit axle width 1m or 1.1m, mount sub frame assembly to your machine using bottom pin holes.

# Spearhead TWIGA PRO

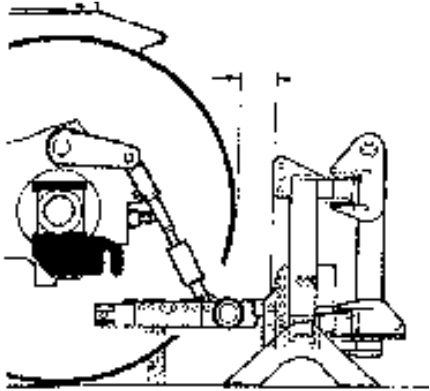

5. Offer up frame to tractor and adjust to give required length. Distance "X" to be kept to the minimum ensuring the machine is close coupled, as a guide set the same as original. Attach tractor lift links to frame with suitable pins.

**Note:** The hole sizes may not match the tractor links, this will not matter as the machines weight will be carried on the stabilisers.

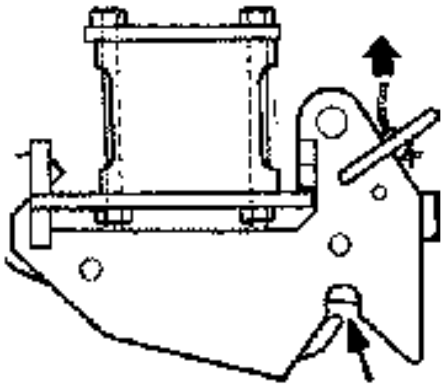

6. Open catch

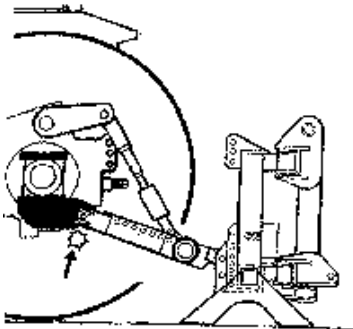

7. Ensure top link is fitted to prevent machine from tipping over before raising. Lift sub frame until it engages in the catches.

**Note:** It is best to mount the sub frame to the tractor first.

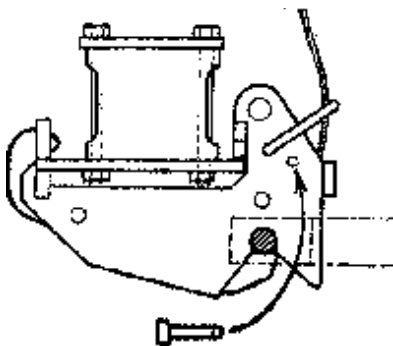

8. Insert latch locking pin

# Spearhead TWIGA PRO

## Attaching Machine To Tractor – Integrated Axle Mounting

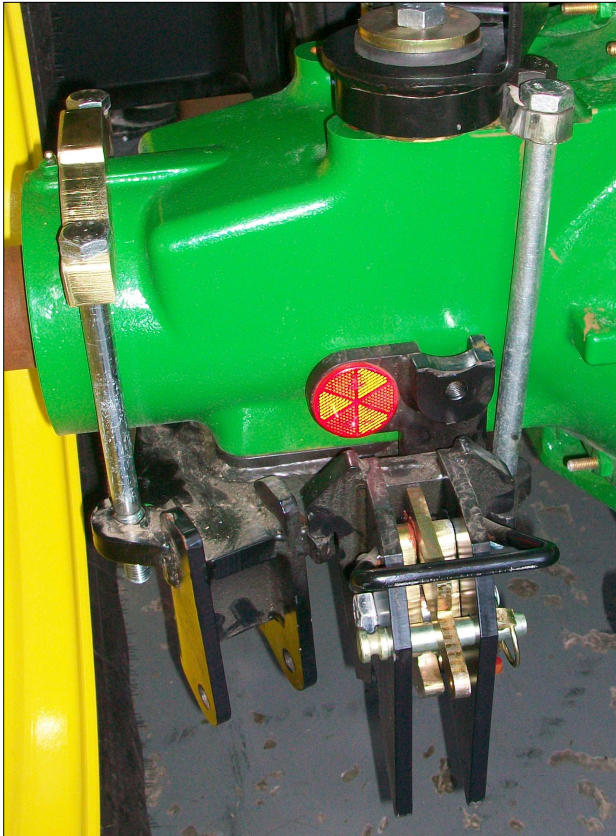

1. Fit the brackets and latches as described in the previous section.

2. Measure the distance between the latch point and the lower link ball (L),

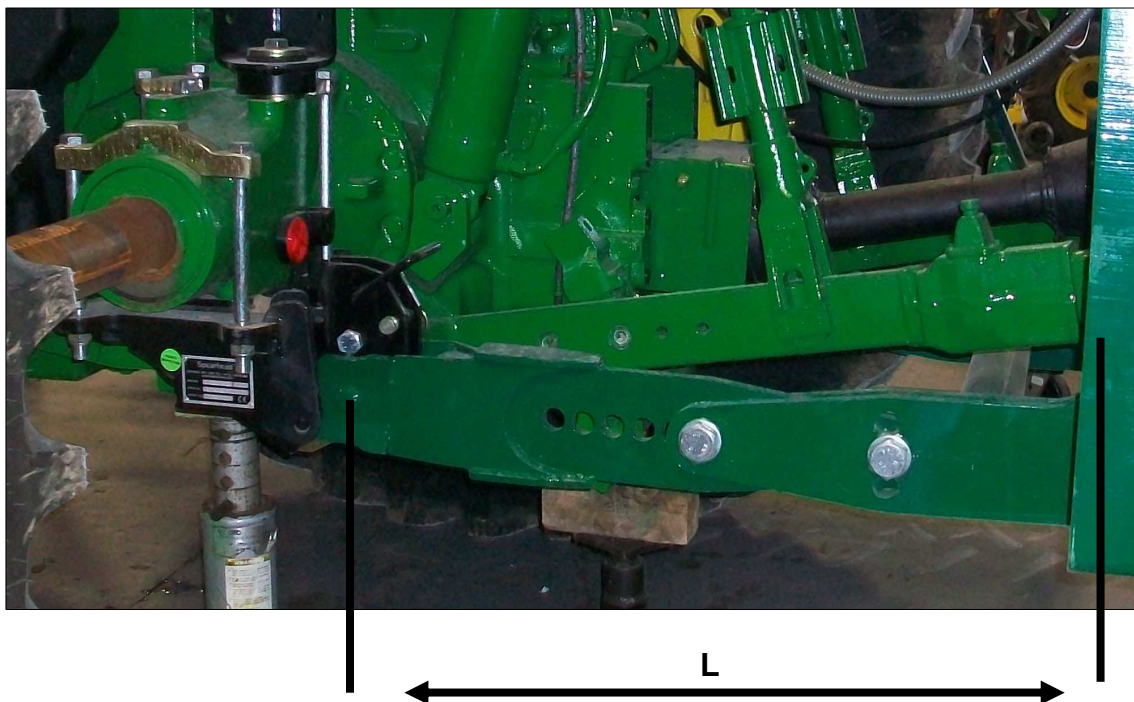

# Spearhead TWIGA PRO

3. You will also need to measure the centres between the latches to ascertain whether you have 1.0M or 1.1M centres, this will determine which way around you mount the arms. Then set the adjustable arms to the nearest setting to match "L" and at the correct width. The rear bolt holes in the arm allow you to set the pitch of the arm to give you a higher or lower setting depending on the tractor.

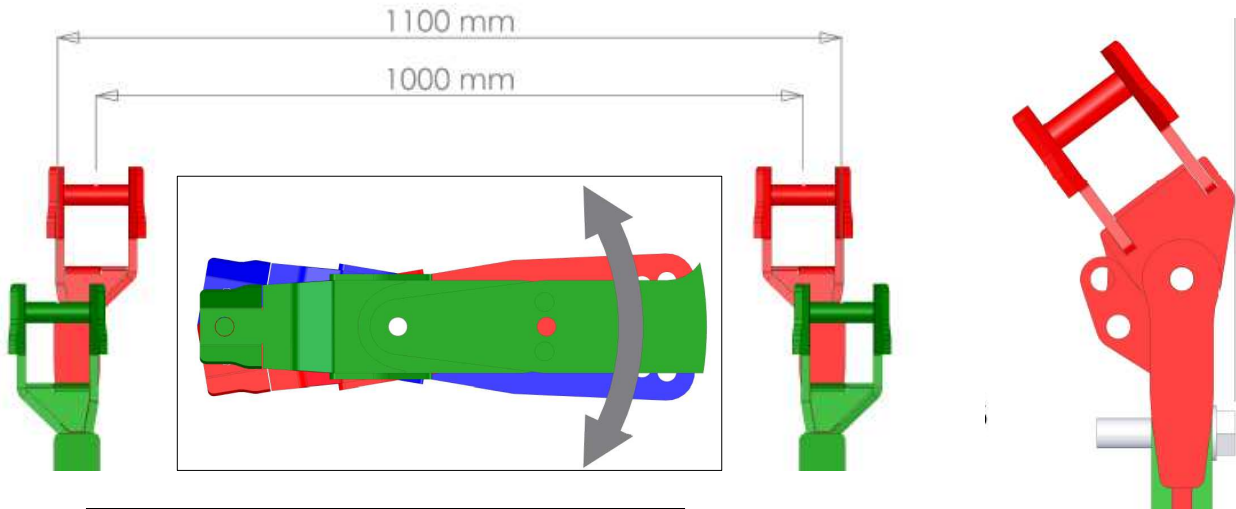

4. Reverse tractor to the machine and attach lower links. If the distance between the rear wheels does not allow for them to pass the brackets you may require an optional set of swinging bracket arms shown above which fold in to allow the wheels to pass.



5. With the P.T.O. and controls mounted as described in the earlier sections you can then raise the link arms to bring the arms into the latches. You may need to slew the arm to the rear of the machine to help the latches engage. Adjust the top link so that the machine sits vertically, the swinging lower link pins will allow for this.



# Spearhead TWIGA PRO

---

## Running Up Your Machine

1. First ensure the rotor is in the 'off' position and P.T.O. drive is disengaged, and then start the tractor.
2. Engage P.T.O. into gear and run machine up to half revs allowing oil to circulate for about 5 minutes before operating arms.
3. Re-check oil level, - check for oil leaks
4. Operate the arms through the full amount of travel, check all movements are functioning correctly.
5. Place flail head near ground in a safe position and with tractor revs low idle, select 'start' position for the flail motor.
6. Once rotor is settled, slowly increase revs of P.T.O. to 540 R.P.M. and run for a further 5 minutes. Slowly reduce revs and then disengage P.T.O.
7. Check all hoses for kinks, pinching, chafing and leaks.
8. Re-check oil level.

### Warning

The rotor will take a long time to stop. Never leave the cab until P.T.O. is disengaged, engine stopped and rotor has stopped spinning.

# Spearhead TWIGA PRO

---

## Removing from the tractor

The following steps **MUST** be followed in exactly the same order in which they appear, with removal of the top link being the last action before driving the tractor away.

Do not attempt to operate machine controls through the rear cab window whilst standing on or amongst the linkage.

1. Select a level firm site such as a concreted surface.
2. Fit parking stands. Place the flail head on the ground approximately 1m out from machine main assembly, to the rear.
3. Ensure head float is discharged and turned off.
4. The arms must be slewed back into transport position and the locking pin fitted to slew post. (Fig. 1)
5. Disengage PTO.
6. Slightly raise the lower lift arms with great care to enable the stabiliser locking pins to be removed.
7. Lower all weight securely onto parking stands (Fig.2).

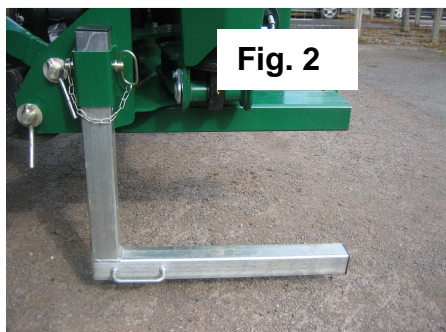

8. Stop engine; ensure all weight is off the tractor and machine hydraulics.
9. Remove stabiliser bars, lower link pins, PTO shaft and control unit from the cab.
10. Remove top link.
11. Slowly drive tractor away.

## Subsequent Attachment to a Different Tractor

Follow the steps for "Attaching your Machine to the Tractor".

# Spearhead TWIGA PRO

## Hydraulic Proportional Controls - 25V

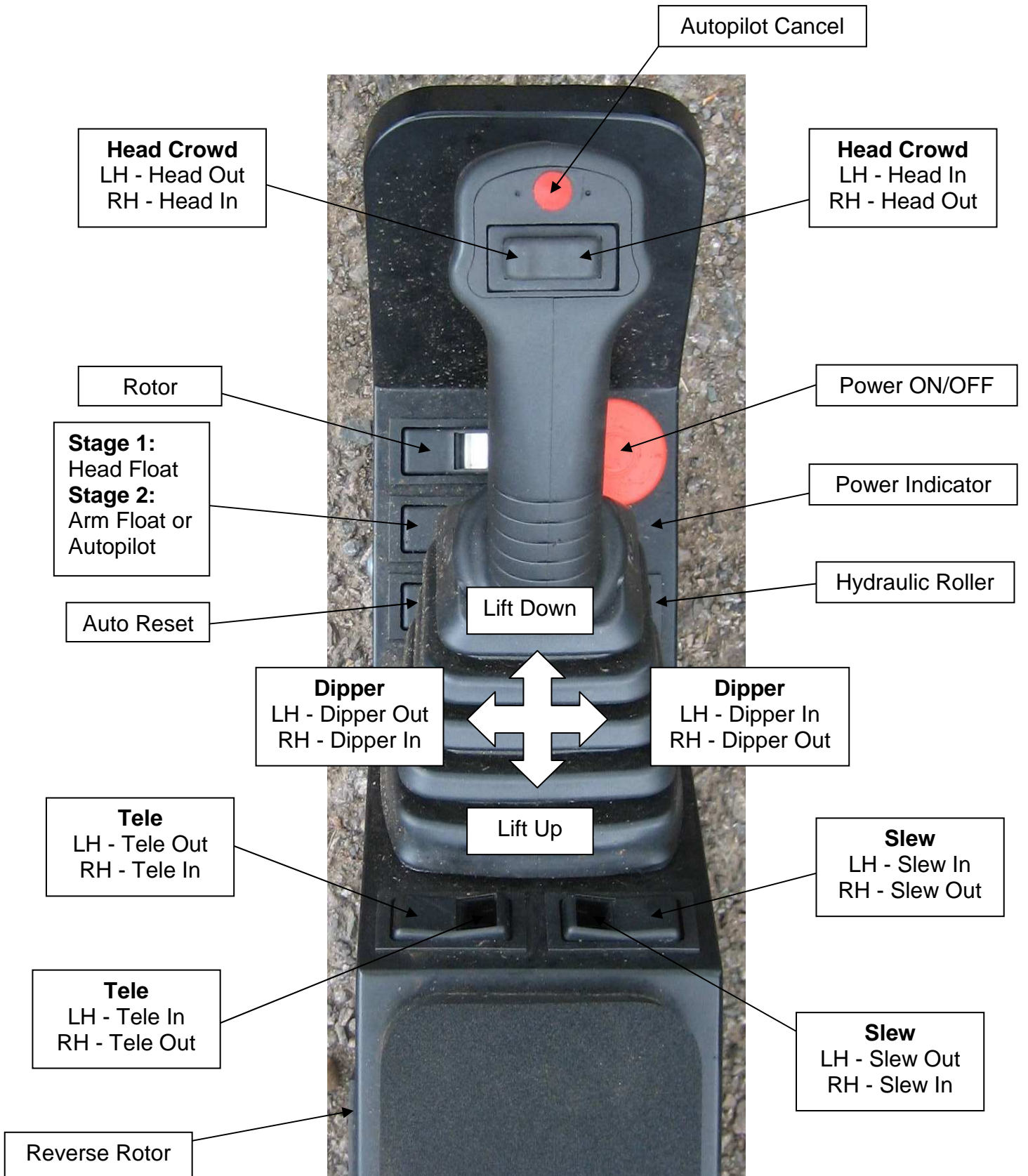

# Spearhead TWIGA PRO

## Hydraulic Proportional PRO PILOT Control - 35V Electric Proportional PRO PILOT Control - 35V

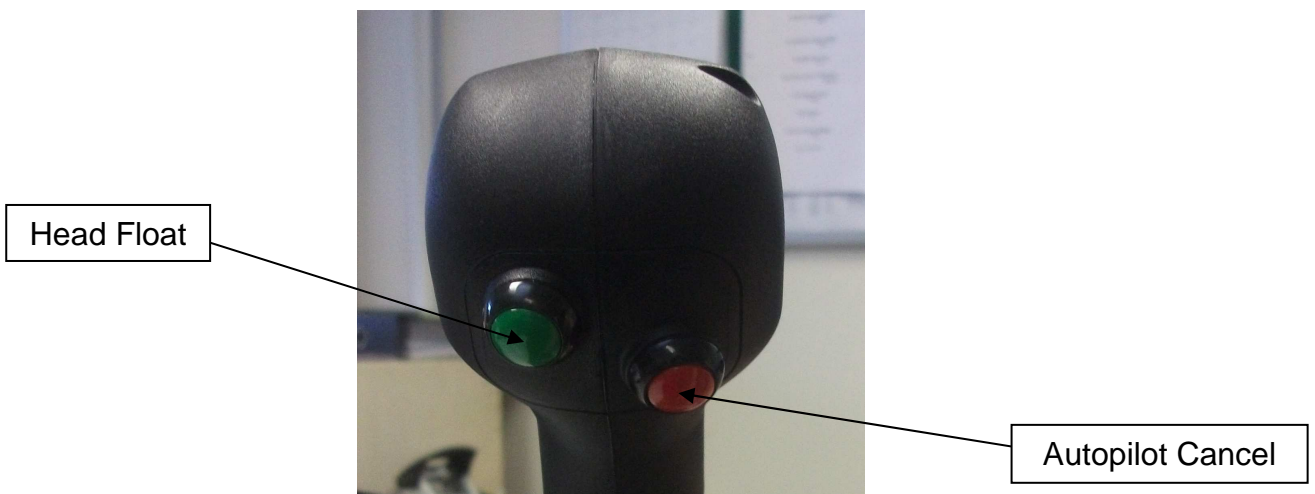
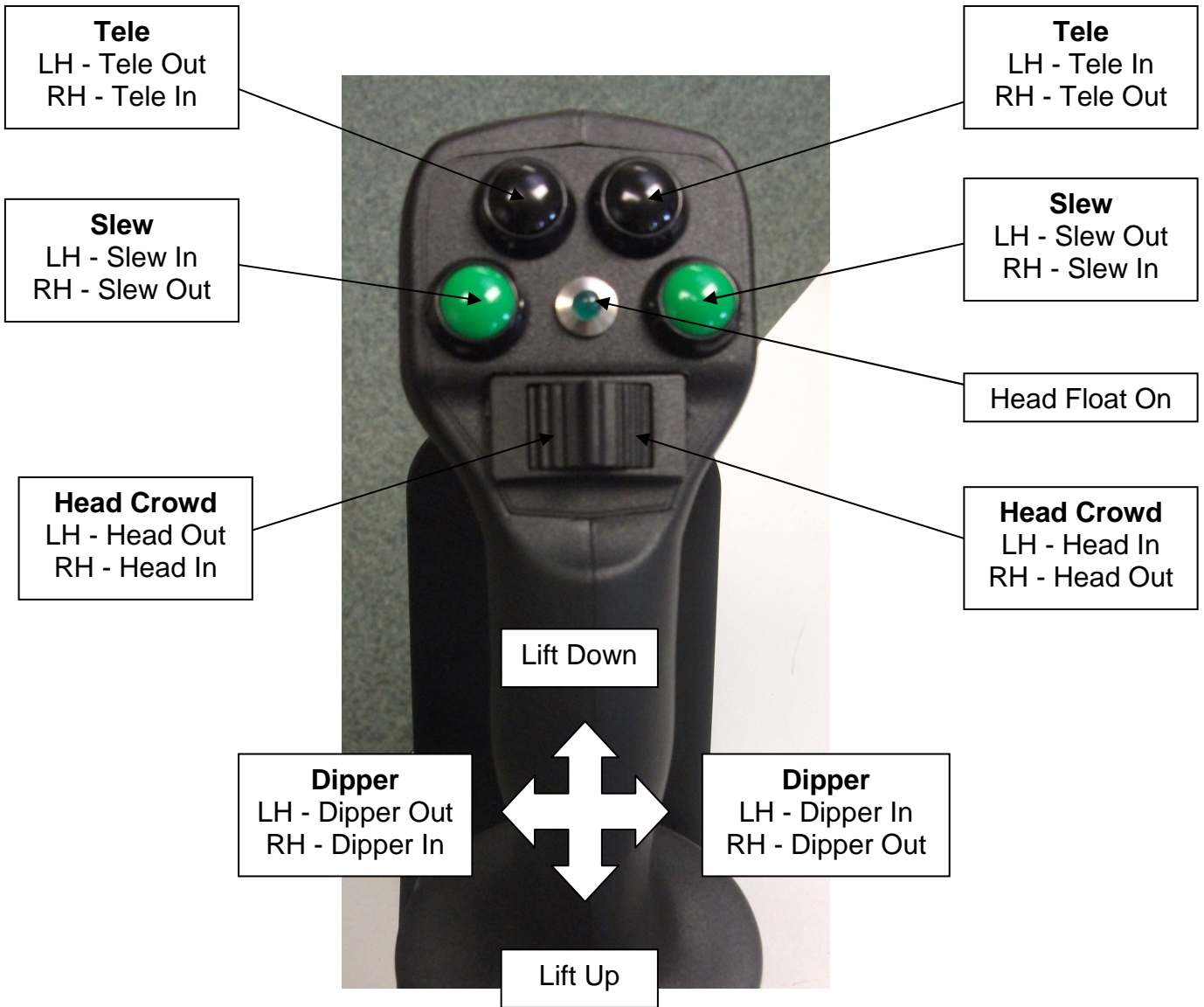

# Spearhead TWIGA PRO

## PRO PILOT Switch Box

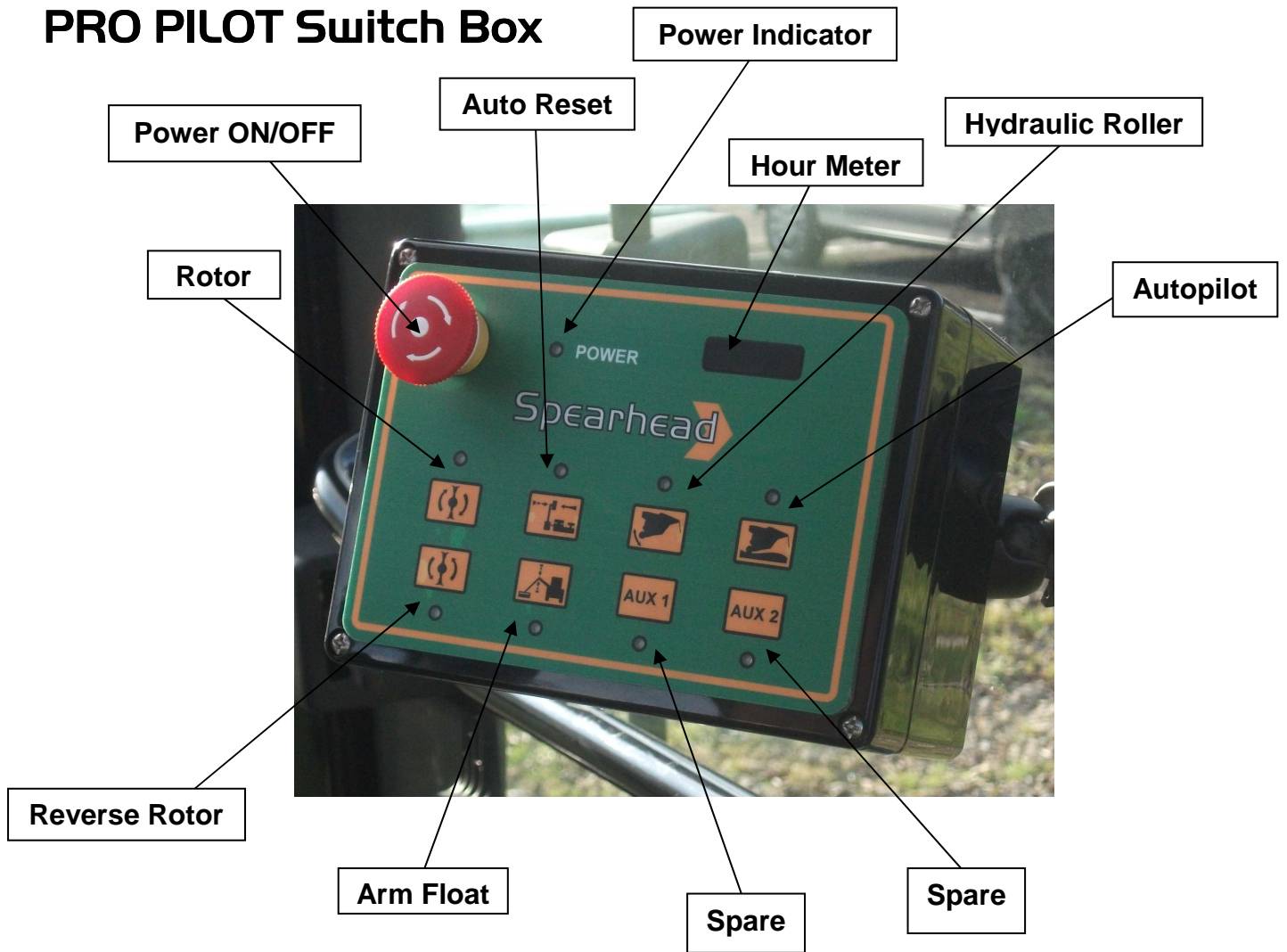

The switch box is supplied with a suction pad to allow the box to be mounted to the tractor cab window for ease of reach.

# Spearhead TWIGA PRO

---

## Operational Warnings

- Never drive the tractor with arm out stretched (except when cutting). When moving at work always first retract arms. Transport with care. Metal fatigue is always caused by careless transportation and misuse. If the ground is uneven or bumpy slow down.
- Read operator's manual and be fully familiar with all operational maintenance and safety procedures.
- Practice in open space without rotor running until familiar with controls. Take care working the head close to the tractor as it may be possible to strike the tractor.
- Remember one of the clever features of the TWIGA range is its ability to operate within a very narrow space, often within the tractors width. This will mean it is quite possible for the flail head to foul the tractor. Practice all these positions and be very familiar with your machine before ever attempting work.
- Never operate above the recommended P.T.O. speed of 540 R.P.M. failure to heed this warning will result in severe damage, i.e. greatly increased oil temperature, risk of rotor going out of balance, as well as reduced machine life, and could cause expensive repairs.
- Failure to start and stop the rotor at a low P.T.O. speed or to operate at the correct speed will result very quickly in severe motor and/or pump damage.
- Be very careful when operating on sloping ground.
- Never attempt to operate the machine while going backwards. It will immediately damage the arms and possibly the flail head. Remember, before selecting reverse gear always lift the flail head out of work and retract the arms towards the tractor.
- Never operate with flail rotor facing towards the tractor. This is potentially dangerous with debris being thrown towards the tractor, and unseen hazards may cause damage.
- Never attempt to slew arms when fully out stretched - always retract before operating the slew. Be very careful when operating on sloping ground.
- Never attempt to slew arms with the head on the ground, always raise the head before slewing.
- Never change/reverse the rotor rotation until it has come to a standstill, serious damage will occur leading to premature pump and/or motor failure.

# Spearhead TWIGA PRO

## Moving into transport position

### Warning

Always transport machine with the slew-locking pin fitted and the arms closed in the transport position on the bump stops. Avoid high transport speeds, which will cause unnecessary strain on machine and tractor.

Never travel with the reach arm away from bump stop on the main arm failure to adhere to this warning will cause damage to ram seals and arms.

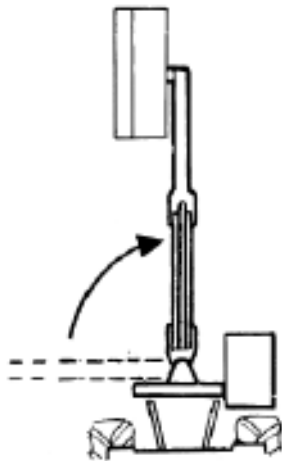

1. Disengage head motor drive.

Ensure that the lift and head float are discharged and turned off.

Retract arms to bring flail head approx. 1 metre from tractor wheel and 1 metre off the ground (close telescopic or VFR where applicable).

Slew rearwards to fully close slew ram

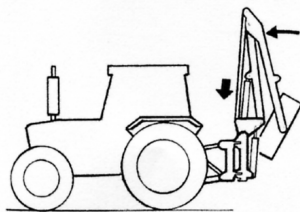
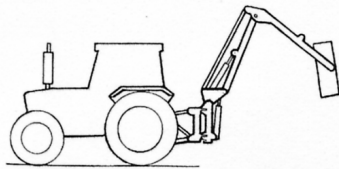

2. Gently close reach arm into cradle and bump stop on main arm.



3. Fold transport stop over.

# Spearhead TWIGA PRO



4. Carefully position main boom over the tractor cab roof until rubber bump stop meets the flip-over transport bracket, allow minimum of 300mm.

**Warning: Bracket must be in correct position or main boom may move over centre and damage cab roof, if positioned too close.**



5. Turn main lift ram isolation tap to off.

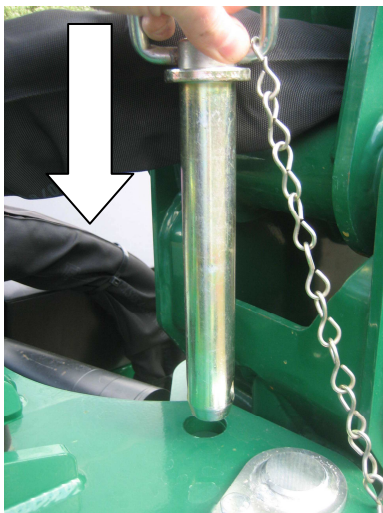

6. Fit slew locking pin to secure slew post to A frame.

**Warning :** Do **NOT** attempt to slew machine until locking pin has been removed, serious damage will occur to machine frame.



# Spearhead TWIGA PRO

---

## Operation

### Transport to work position

- Remove locking pin from slew post.
- Turn lift ram isolation tap to on position.
- Ensure rotor/motor switch is off.
- Engage PTO low revolutions.
- Lower main lift ram only, until main arm is vertical.
- Extend dipper arm outward.
- Flip transport stop over to clear lift frame.
- Slew arm forward through 90°.
- Position head till horizontal, just above ground.

### Engaging Head Drive

- Select 540rpm PTO and run with low engine revs.
- With flail head in safe position switch rotor control to 'ON'.
- **Cold start** - it is important not to run at full speed with cold oil. Run at low speed for at least 15 minutes to allow oil to warm up.
- Afterwards slowly increase engine revs to obtain correct PTO speed, 540rpm.
- Never attempt to start rotor while under load.



### Disengage Head Drive

- Slowly decrease engine revolutions to a fast idle.
- Move rotor control lever (5) to 'OFF'.
- Never increase or decrease PTO speed rapidly, this could seriously damage pumps and motor.

# Spearhead TWIGA PRO

## Reversing Head Drive

- Ensure the rotor has stopped spinning or is not blocked; failure to ensure this will cause irreparable damage to hydraulic components.
- Change rotor rotation via the button on the PRO PILOT 3SV or rocker switch on the 2SV, which is fitted with a locking gate to prevent accidental movement.



## Break Back

### Manual - Yellow Switch “Off”

The Twiga range of reach mowers have as standard a slew ram to position the machine from transport to work or any position midway for narrow lane cutting. This ram also acts as the break back ram for machine protection should an obstacle be encountered while travelling forward.

The break back will operate if the machine is overloaded i.e. a dense patch of vegetation, too high a forward speed, and when working uphill. The tractor must be halted and the flail head manoeuvred around the obstacle before the break back is reset via slew control lever / switch.

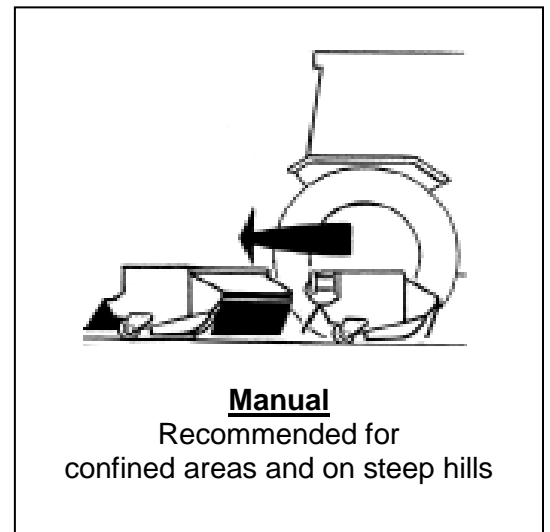

## Auto Reset

### Auto Reset - Yellow Switch “On”

This is recommended for normal use either verge mowing or hedge cutting. When auto reset is selected the flail head rises as the arm slews back past an obstacle, once past, the weight of the head causes the arm to automatically slew forward and down to the original position. Therefore, when verge mowing, too much weight on rear roller will cause arm to break back prematurely, as will too high a forward speed and a dense crop.

Under certain conditions it may be beneficial to turn off auto reset and operate break back manually, especially in confined areas and up steep hills.

**Never attempt to operate the machine when travelling backwards, the break back will not function and any damage caused will not be considered warranty. The break back feature does not excuse the machine operator of their need to be aware of obstacles and to avoid hazards. It is your responsibility to maintain a long reliable working life.**

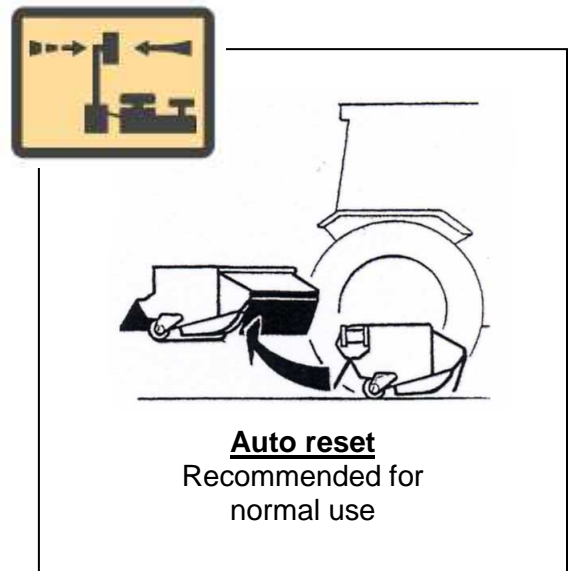

# Spearhead TWIGA PRO

---

## Oil Cooler

The optional fitment of an oil cooler prolongs the life of the hydraulic oil and components in hot and arduous conditions.

It is important to connect the power lead to the control box directly to the tractor battery.

It is essential to keep the radiator clear from debris to ensure a free air flow that will effectively keep the oil cool.

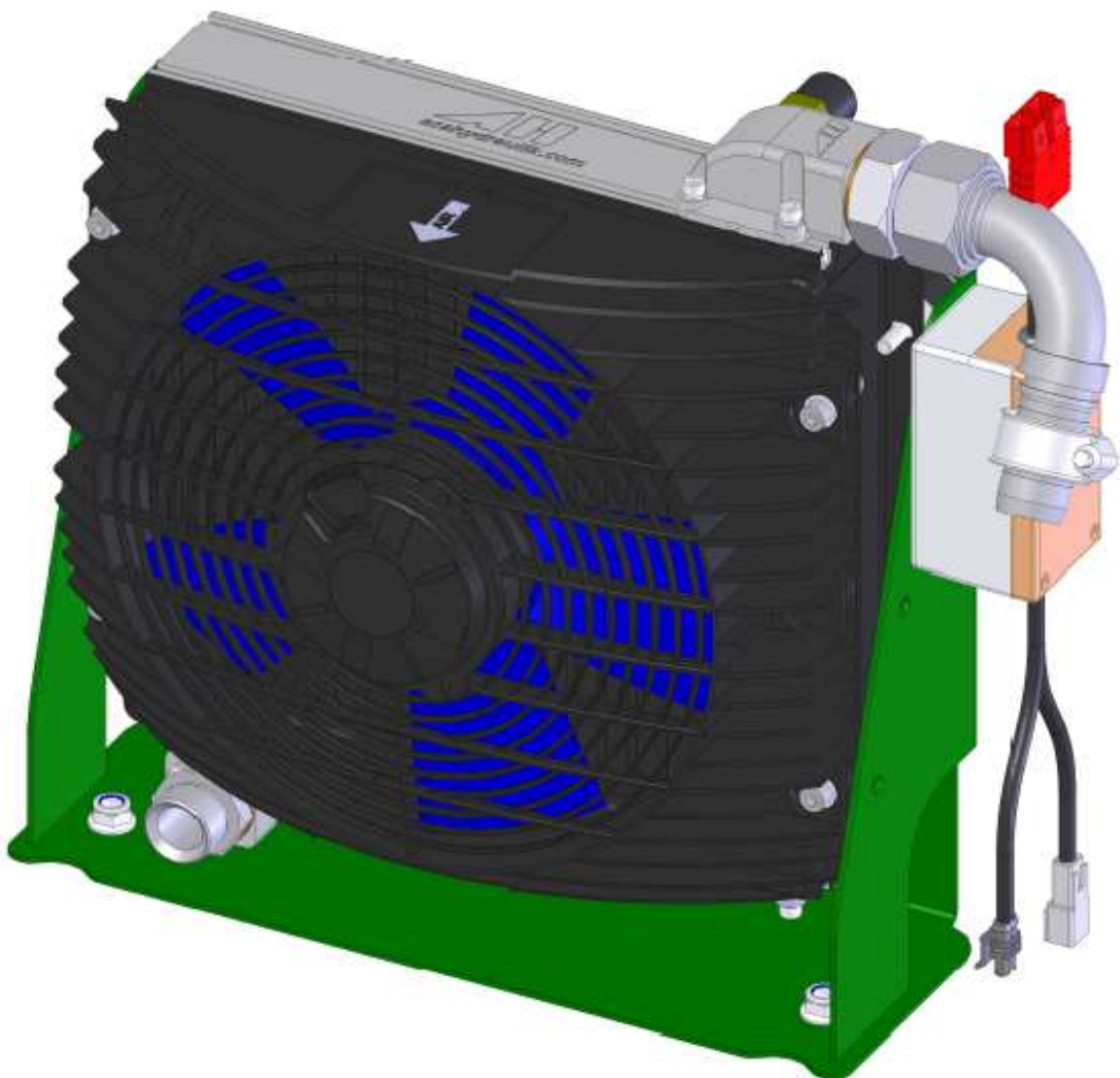

# Spearhead TWIGA PRO

## Head Float



Head Float



Hydraulic Control

Green switch

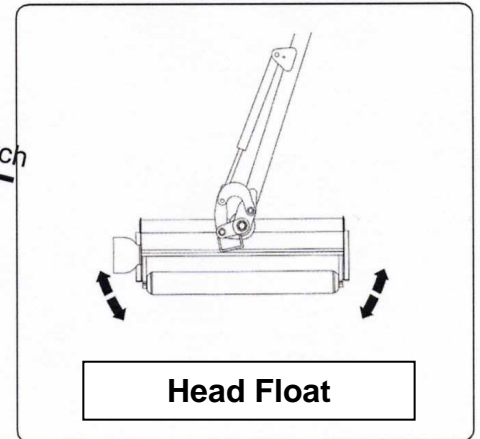

This option allows the flail head to follow contours of the ground without having to constantly control the angle of the head.

The centre of balance is the best mounting point for the head if head float is to be used properly.

### Operating The Head Float

Place flail head on the ground and switch on head float control, this opens the head ram to tank, and allows the ram to float in or out, maintaining full contact with the ground automatically. Note, the rotor must be switched on and running to provide electric supply to the head float.

To regain manual control switch off by pressing the green rocker switch.

### Warning

Do not fold the machine up for transport before turning off the head float.

# Spearhead TWIGA PRO

## Arm Float

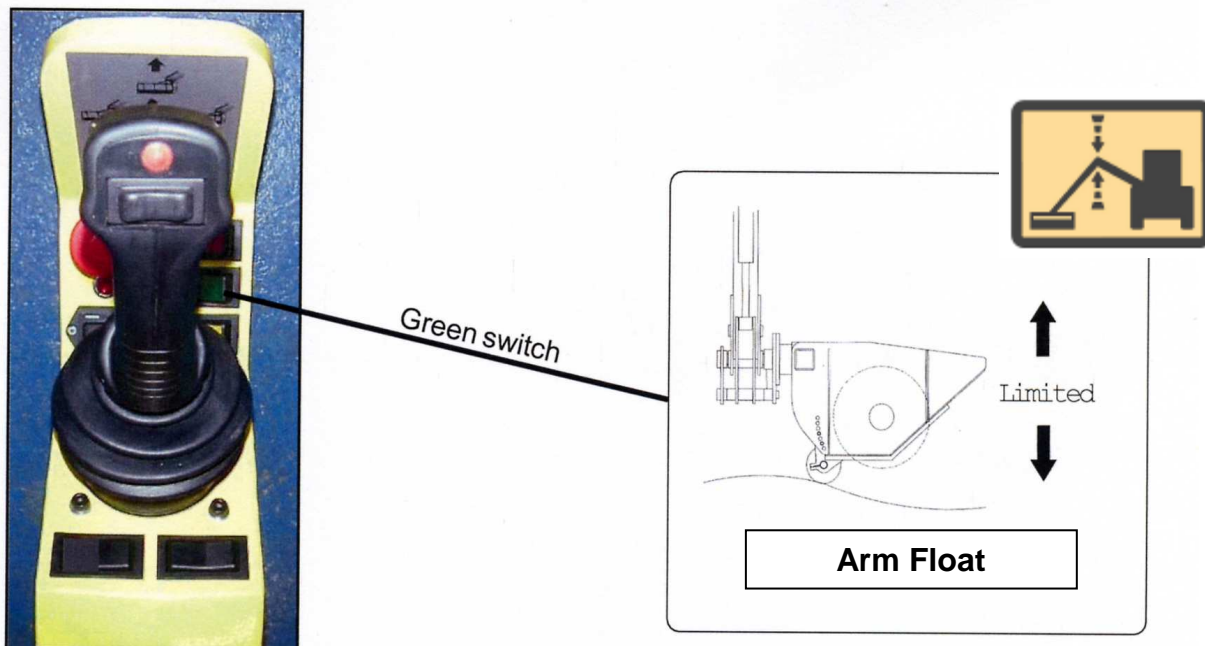

This is only to be used in verge mowing set up, it will reduce weight on the rear roller allowing head to move more easily, following small changes in ground contours in a forward motion, with the aid of a pre-charged gas accumulator.

### Operating The Arm Float

To select arm float, first lower the flail head to the ground before operating the switch. The main lift control lever should be operated to take a proportion of the flail head weight off the rear roller. This is important, as too little weight on the rear roller will leave uncut areas of grass, too much weight on the roller will cause scalping in places and increase flail wear and damage. We strongly recommend the use of auto reset - break back.

When the head is pushed further out more weight will be applied to the accumulator causing the head to drop, reset with control lever.

As the ground contours alter it is necessary to reset the pressure within the main lift circuit as above, constantly raising or lowering control lever.

### Warning

Do not fold the machine up for transport before turning off the arm float and discharging the pressure from the lift circuit.

# Spearhead TWIGA PRO

---

## Debris Blower



Hydraulically driven fan from tractor external services, please quote tractor oil flow when ordering (maximum 40lt per min).

The return oil must go to a free flow connection i.e. filler plug. Avoid quick release couplings.

### **Operating The Debris Blower**

The fan is suitable for clearing cuttings off the highway; we recommend the Blower is used on final cut only and not continually on.

Excessive use may cause overheating. The unit can be angled for the best effect.

### **Transport**

The Blower housing protrudes and care should be taken not to damage unit.

# Spearhead TWIGA PRO

---

## Hydraulic Rear Roller

The hydraulic rear roller is controlled by a switch on the control panel. The control of the rear roller is either raised or lowered, there is no in-between height control. Height is set as above for either hedge or grass cutting

### Note

To ensure the roller moves freely it's important to keep the roller linkage clean and lubricated.



Green Switch



# Spearhead TWIGA PRO

## Autopilot

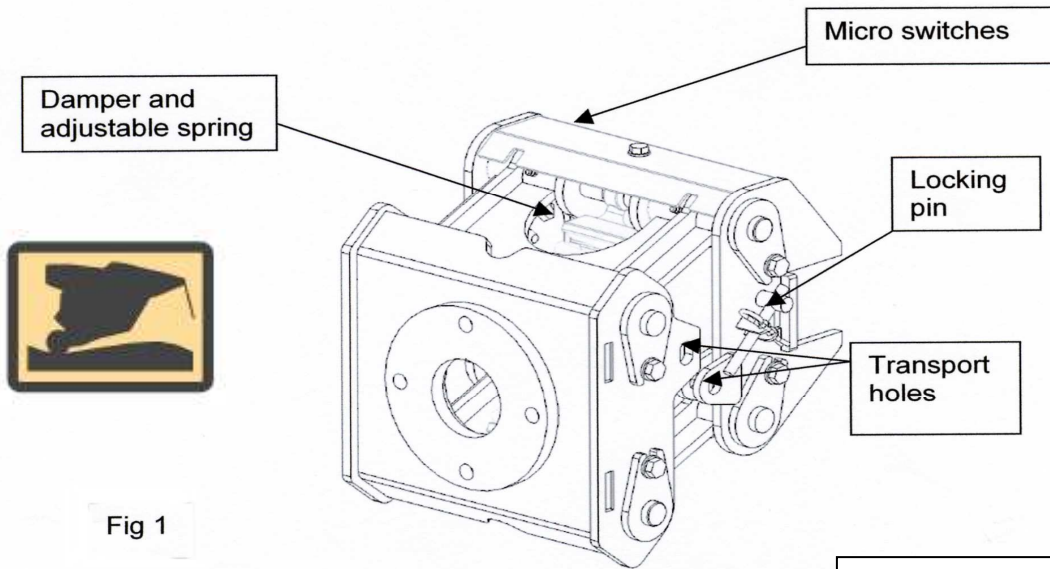
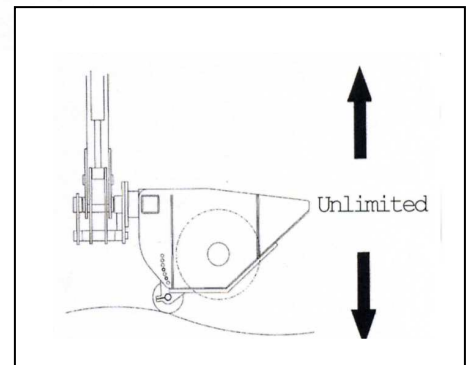

Fig 1

### Introduction To The Autopilot

The Spearhead Autopilot is an automatic control system for use when cutting on the ground. It operates by sensing the weight on the rear roller and maintaining this within a narrow band without the attention of the operator. When the angle of the area being mown is more than 45° to the horizontal, it is best to switch off the Autopilot and operate the machine manually until the angle becomes more normal. The middle position of the green switch will allow angle float without autopilot.



Autopilot will only operate when the cutting head rear roller is in contact with the ground.

If the machine is going to be used for long periods of time at hedge cutting it is recommended to remove the Autopilot assembly between the dipper arm and head and replace with standard head bracket .

### Warning

To adjust the Autopilot, the operator must remove the panel mounted fuse on the control panel, which isolates the rotor (see right).



Ensure you fully understand the operation of the Spearhead Autopilot, which will reduce machine and operator fatigue and improve hourly output, machine life, standard of work and comfort to the operator.



# Spearhead TWIGA PRO

---

## Set-Up: Correct position of micro switches

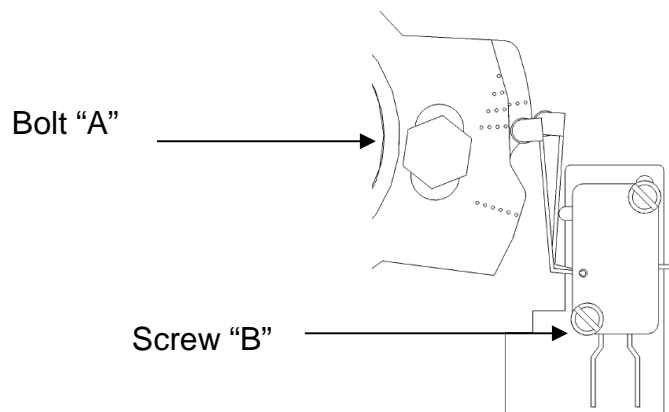

Fig. 2

1. Place rear roller on the ground
2. Ensure the locking pins (fig.1) are installed into the Auto-pilot with the arm fully lowered
3. Engine turned off, key removed and PTO disengaged.
4. Slacken bolt ("A" fig 2) and adjust cam plates until they are flush on the top.
5. Slacken screws ("B" fig 2) to adjust switches; the lever arm must rise on the cam as shown sufficiently to make the circuit. The switch will give an audible click, if necessary bend the lever arm towards the cam to ensure the switch makes a circuit.
6. Remove the locking pin from the auto-pilot and raise the main arm and rear roller off the ground 0.5 m, now check the opposite switch has risen up the other cam and the switch has made a circuit.
7. Remove the fuse mounted in the control panel and start the machine, turn on the rotor switch (the rotor should not spin) and turn on the autopilot. The arm should rise if the arm head was fully lowered or drop if the rear roller is off the ground, and the 2 switch arms should come to rest in the valley between each cam peak.
8. The system can be checked for operation by depressing the red isolator button on the top of the joystick handle, fully lowering the main arm, bring joystick to neutral and releasing the red button. The autopilot should now reset the arm up until the switches rest in the valley.

## Warning

Ensure the engine has stopped and the key is removed, the PTO is disengaged, handbrake secure, and the head is firmly on the ground before attempting any servicing, maintenance or adjustment.

# Spearhead TWIGA PRO

## Summary

You must ensure that the micro switches make and break a circuit as the cams rotate through their arc of travel. It is very important to correctly set the micro switches to ensure the electrical circuit functions, the switch lever arm must follow its own cam and not be influenced by the opposite cam also the lever must be bent towards or away from the cam to allow the electric circuit to open and close in accordance to the cam position

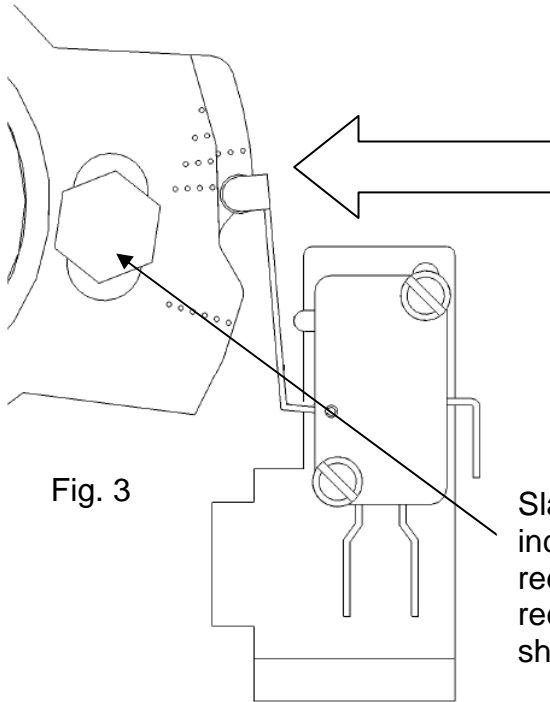

### Autopilot

When both switches are open the main arm will hold position, this is neutral or mid position when they rest in the valley between both cam peaks.

Slacken this bolt before adjusting the position of cams, increase sensitivity by moving the cam peaks together reduce auto pilot sensitivity by moving them apart. We recommend the cam plates are flush at the top as shown.

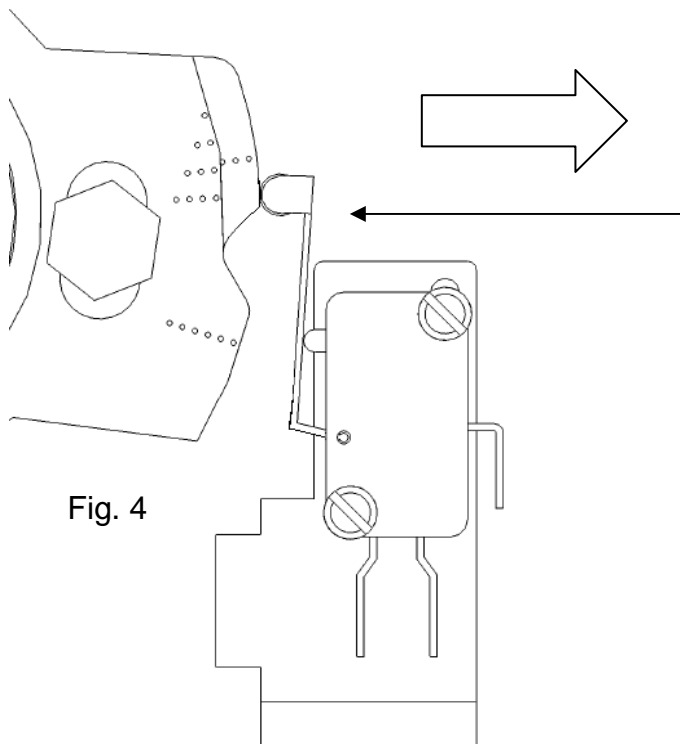

Ensure the switch lever closes the contacts, if not adjust by bending the lever arm towards the cam.

### Autopilot

When one of the switches is closed, main arm will either raise or lower dependant on which switch has been triggered.

# Spearhead TWIGA PRO

## Auto Pilot Switch Alignment

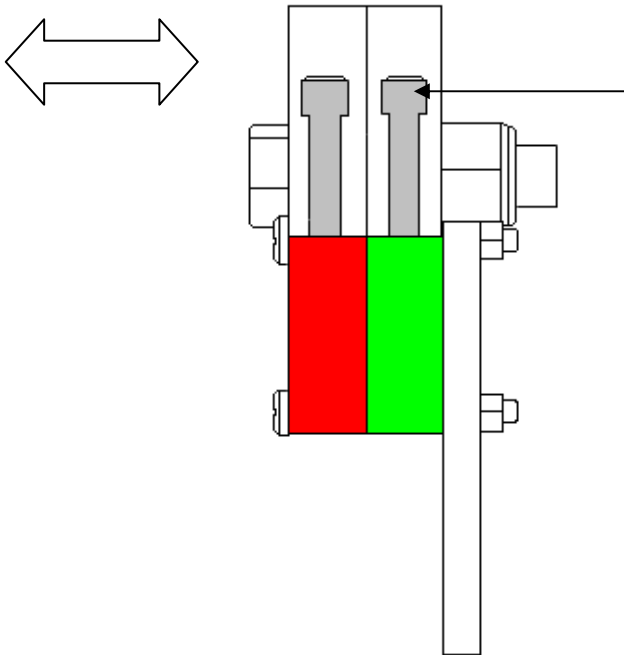

Bend lever arm of switch to align with the middle of each cam, ensure they don't overlap onto the adjacent cam.

## Alternative Settings

Move the cams apart to increase amount of weight carried on the rear roller, thereby reducing the sensitivity of the auto-pilot. If the cams are too close together the switches will constantly be altering the main arm height causing unnecessary wear and strain on the hydraulics.

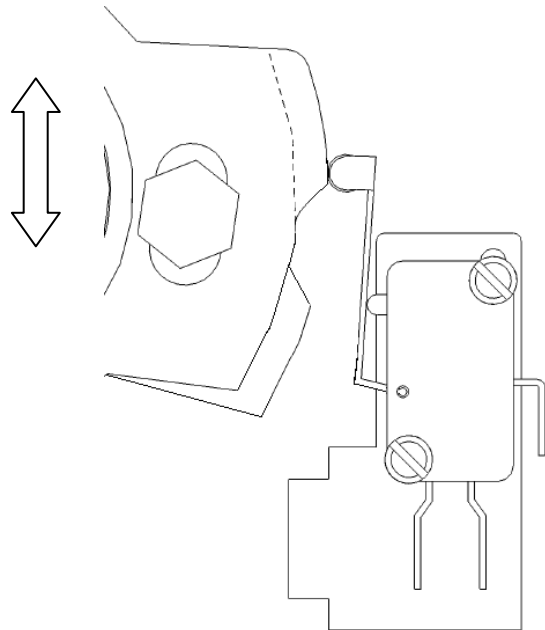

## Warning

If the working range is altered the spring length on the damper may need adjusting to compensate.

Note: The basic factory setting for the spring length is 200mm

# Spearhead TWIGA PRO

---

## Operation Of The Autopilot

To activate Autopilot first slew the head into work position and lower the head horizontally onto the ground.

Remove the 2 transport pins. Raise the head 300 - 400mm off the ground and ensure Auto slew is switched on, engage rotor drive and then switch on Autopilot. The head will gently drop to the ground and be ready for work.

Your forward speed will be determined by ground conditions, density of growth, height of cut and generally operating within a safety margin to allow you time to react to any unexpected occurrence.

Once in work the Autopilot will control the head height and angle, allowing the head to accurately follow all the ground contours. The operator will control reach whenever necessary.

The Spearhead Autopilot will assist you with grass mowing. It does not relieve you of your responsibility to drive with care and understanding for the machine.

When crossing "grips" or drainage gullies, it may be necessary to temporarily lift with the main ram using hydraulic joystick and the red isolator button.

If you approach larger areas not to be mown i.e. road junction, bridges and crash barriers, it will be necessary to switch off the Autopilot, enabling you to raise the head from the ground.

Before switching on the Autopilot please ensure the head is within 300 - 400mm from the ground. Always ensure that the Auto-break-back is switched on when operating with the Autopilot.

## Transport of the machines with Autopilot

1. Turn off autopilot switch (green)
2. Ensure all locking pins are fitted to mainframe, slew, height stop and auto pilot bracket.
3. Ensure machine is folded to the recommended position
4. Turn off isolator switch (red)
5. Disconnect electrical supply.
6. Disengage PTO

## Warning

Autopilot is not suitable in extreme conditions i.e. very steep banks and very wet conditions. Always ensure the rear roller is not "clogged" with mud. If the machine starts to move uncontrolled, isolate by turning off the green switch, place the head on the ground, follow point 4, 5 and 6 above. Turn off the tractor, apply parking brake and remove the ignition key, then inspect machine for fault.

# Spearhead TWIGA PRO

---

## Quad Saw

- Never operate the machine with other people present, as it is possible for debris to be thrown from the saw blades in all directions.
- Always ensure all cab safety guards are in place and all tractor windows are closed. Never allow an inexperienced person to operate the machine without supervision.
- Never allow children to play on or around the machine at any time.
- Never attempt any maintenance or adjustment without first disengaging the PTO/ hydraulic pump, lowering the head to the ground, stopping the tractor engine and applying the tractor's parking brakes. Before leaving the cab remove the ignition key, never stop the engine with the PTO engaged.
- Before leaving the tractor cab always ensure that the saw head is firmly on the ground no weight is on the tractors hydraulics and blades have stopped spinning.
- Always check that all guards are properly fitted, check there are no damaged or loose parts.
- Always operate the blades at a speed between 3000 - 3200 R.P.M.
- Maximum oil pressure of 250 bars in the hydraulic hoses.
- Never transport without the blade protection guards mounted.
- Always inspect work area for wire, steel posts, large stones and other dangerous materials. If such items are found remove them.
- Never attempt to use the machine for any purpose other than that it was designed for.
- Ensure that all warning labels are always visible and that they are not damaged, defaced or missing.
- P.T.O. speed 540 R.P.M.

# Spearhead TWIGA PRO

## Technical Data & Description

Each shaft is driven by vee belts, and the whole unit is powered by a hydraulic motor. Branch carriers are placed between the blades.

The Quad saw is supplied with a special bracket enabling mounting on various vehicles and machines.

## Belt Diagram - Quad Saw

Frame with 4 shafts.	Working width	2000mm
	Blade speed	3000 - 3200 R.P.M.
	Blade diameter	500mm
For mounting on hydraulic hedge cutters	Teeth per blade	72
	Materials	Hardened steel with special teeth HM precision blade
	Performance	1 - 120mm branch diameter
500mm saw blades	Application	Vertical
	Relief valve pressure	Max. 120 atmospheres/bar

It is important that the belts are correctly mounted and tightened. When new belts are mounted they must be tensioned to 700N for the short and 900N for the long belts.

After 10 to 15 working hours the belts may have slackened and must be checked.

**Beware!** The tension has now changed to 550N for the short and 650N for the long belts.

Contact the Spearhead Service department if you have any questions.

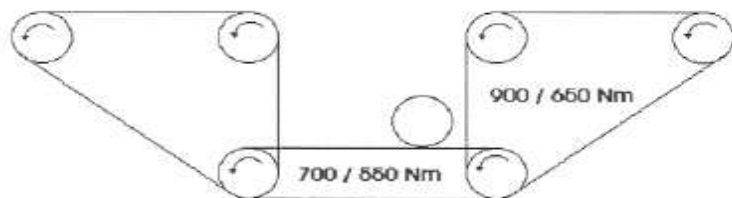

## Mounting the Quad Saw

The blades must be mounted in a downward cut rotation. Always use the blades vertically positioned in relation to the direction of travel.

The hydraulic hoses must be connected correctly to achieve the correct direction of rotation. Drainage hose must be lead directly to the oil reservoir. Daily inspect all hydraulic hoses and fittings for damage or leaks.

When starting for the first time the speed of rotation on the blades must be measured (3000 - 3200 R.P.M.). This rotation should be maintained to ensure optimum performance.

# Spearhead TWIGA PRO

## Quad Saw Operating Instructions

It is recommended to travel forward slowly when starting work in order to maintain the correct speed of the blades. Adjust the angle of the saw to present the branches approx 90° to the blades. Always ensure the blades are vertical to allow cut branches to fall away. If a large branch is approaching adjust the working height to ensure it meets the centre of a blade.

Do not use horizontally there is a danger the weight of the cut branches will bend the blades, however 45° is permitted for trimming material up to 40mm diameter.

The Quad saw will cut up-to 100mm maximum, branches over 80mm must be cut one at a time, pausing forward travel to allow the saw time to cut each branch.

In the event of small twigs or debris jamming the saw blades, stop the machine immediately and clear the blockage with a suitable tool.

Ensure there is a skid mounted on the bottom of the saw attachment to protect the lowest blade from striking the ground.

## Warning

Take care not to bend the blades in storage or during work. The blades must be inspected daily for signs of fatigue and cracking, do not use the machine with damaged blades they must be replaced immediately.

Before starting the saw for the first time after connecting the hoses, you must ensure the hydraulic motor is primed with oil and the case has filled with oil, via the small hose connection. Failure to fill the motor case with oil will lead to seizure due to lack of lubrication.

## Note:

To change rotation of motor exchange the position of the pressure/returns hoses and the anti-cav valve with the plug.



## Cutter Bar

### Description

The optional 1.5m cutter bar is a robust construction of double fingers and reciprocating knife, suitable for cutting shrubs and hedges of a woody material up to 30mm diameter.

### Operation

Run the PTO at low speed 150/200 rpm only; normal 540 R.P.M. will cause unnecessary wear and vibration, which may lead to premature failure. Position the arm and knife into the work and select a suitable forward speed, which allows the blade to cut all material without blocking. When trimming material towards the limit of the cutter bar avoid making arm movements and reduce your forward speed to allow the knife to time to clear.

### Maintenance

- Grease motor body (5 pumps every 50 hours)
- Grease knife drive (1 pump every 50 hours)
- Check tightness and security of all nuts and bolts
- Sharpen or replace worn or damaged blades and fingers

### Safety

- When cutting material take care as the branches may fall towards the tractor, always using appropriate guarding on cab glass.
- Never attempt to unblock a jammed knife by hand, always use a suitable tool.
- Always ensure the knife guard is in place before transporting machine.
- Always position the arms and cutter bar on the ground or stands before attempting any maintenance.
- Always disengage the P.T.O. and switch off the engine before attempting and maintenance on the cutter bar.
- Always ensure the engine is switched off, the key removed and the knife has stopped before dismounting the tractor.
- Ensure no person or vehicle is in danger from falling debris in the working area.
- Inspect the work area for hidden obstacles, wire, posts, rocks etc, which may damage the blades or machine.
- Avoid angling the arms or cutter bar into a position, which may contact the tractor, causing damage.



# Spearhead TWIGA PRO

---

## Telescopic Arm

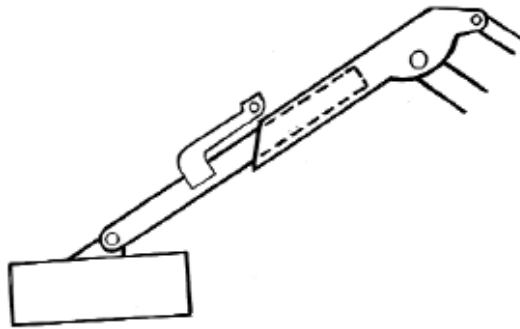

### Description

Telescopic extending arm provides extra reach, particularly useful for deep ditches, banks and for reaching high hedges.

### Operating the Telescopic Arm

Use the electric switch to adjust the length of the extending telescopic dipper arm to suit working conditions and use dipper ram to vary reach as required.

Over frequent use of telescopic arm will cause premature wear of adjustable pads.

### Transporting the Telescopic Arm

Always fully retract before folding machine arms into transport position.

# Spearhead TWIGA PRO

---

## Variable Forward Reach (VFR)

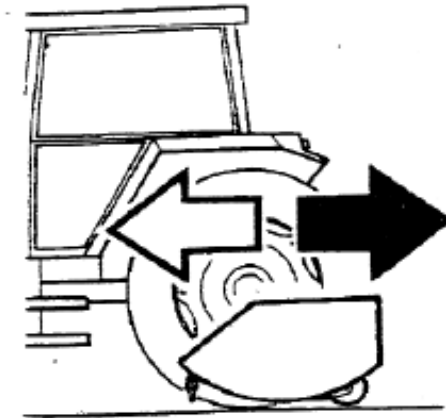

### Description

This useful feature provides extra visibility particularly when topping a hedge, or verge mowing.

### Operating the Variable Forward Reach

Before operating the arm, ensure the head is one metre off the ground and at least two metres away from the tractor. To operate the arm, press rocker switch. This will push the head forward. Likewise press the rocker switch opposite, the head will retract backwards. When operating the cutting head close to the tractor extreme care must be taken to avoid contact with the cab.

### Transporting the Variable Forward Reach

**Never** attempt transport position without first fully retracting the forward reach arm.

# Spearhead TWIGA PRO

## Service and Maintenance

### Daily grease points

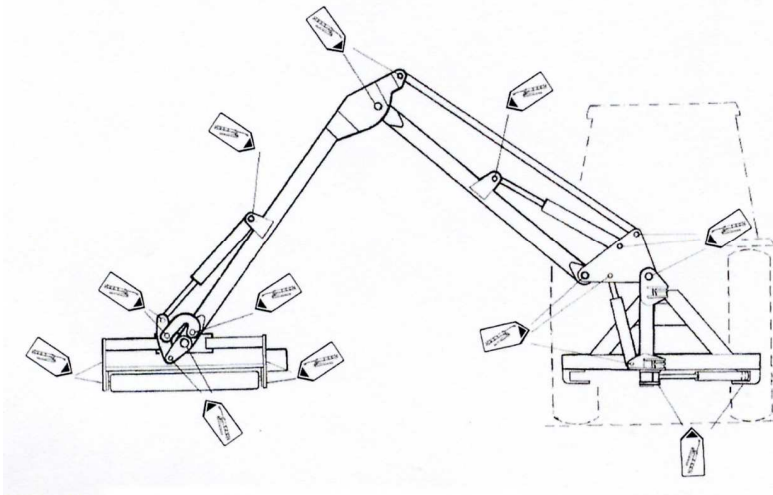

**TWIGA machine**

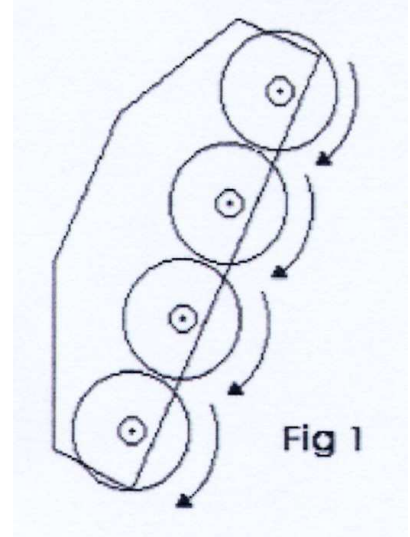

**Optional - Quad saw**

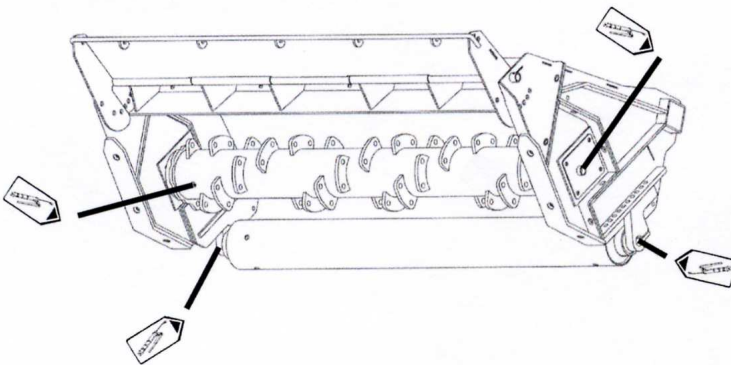

**Head Rotor & Roller**  
Grease 1.2m head every 8 hours (5-10 pumps)

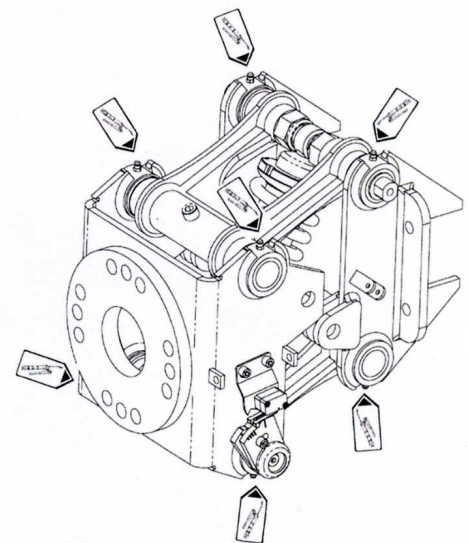

**Optional - Autopilot**

# Spearhead TWIGA PRO

---

## Washing your machine

Grease all your machine and optional parts after each time you wash your machine.

## Gearbox

Before first use check gearbox oil level, thereafter check every 8 hours. After the first 50 hours drain and replace the gearbox oil, thereafter annually. Replace with EP90. Do not over tighten oil plugs, as this will damage the housing.

## P.T.O.

Dismantle; clean the input drive shaft sliding surfaces and re-grease, failure to do this will result in serious damage to the gearbox. Grease both U.J. joints every 8 hours.

## Oil Requirements

Fill the tank to centre of sight gauge with approximately 220 litres of HD46 or equivalent oil. Do not over fill.

## Torque Settings

The Torque figures given below are recommended maximum settings only.

Size:	Tensile strength:	Description:	Torque setting: Nm.
M10	8.8	General fasteners	65
M12	8.8	General fasteners	114
M12	12.9	Head bolts	170
M12	10.9	Flail bolts	100
M16	8.8	Head bracket bolts	280

# Spearhead TWIGA PRO

## Hydraulic Hoses

- Carefully check condition of all hoses during routine service paying particular attention to chafed outer casing. Secure wrap with waterproof adhesive tape to stop the metal braid from rusting.
- Daily inspect all hydraulic hoses and fittings to be in good order. Any damages or leaks must be rectified immediately; this is part of the daily maintenance and is your responsibility, to ensure a long reliable working life.
- Hoses with damaged metal braid should be replaced.
- When replacing hoses quote number stamped on fitting at one end. The Spearhead hydraulic system works at very high pressure, when replacing hoses use only genuine hoses, a burst hose could be very dangerous.
- When replacing hoses to avoid twisting fitting, use two spanners to slacken and tighten.

### Warning

Hose is weakened when installed in twisted position. Also, pressure pulses in twisted hose tend to fatigue wire and loosen fittings.

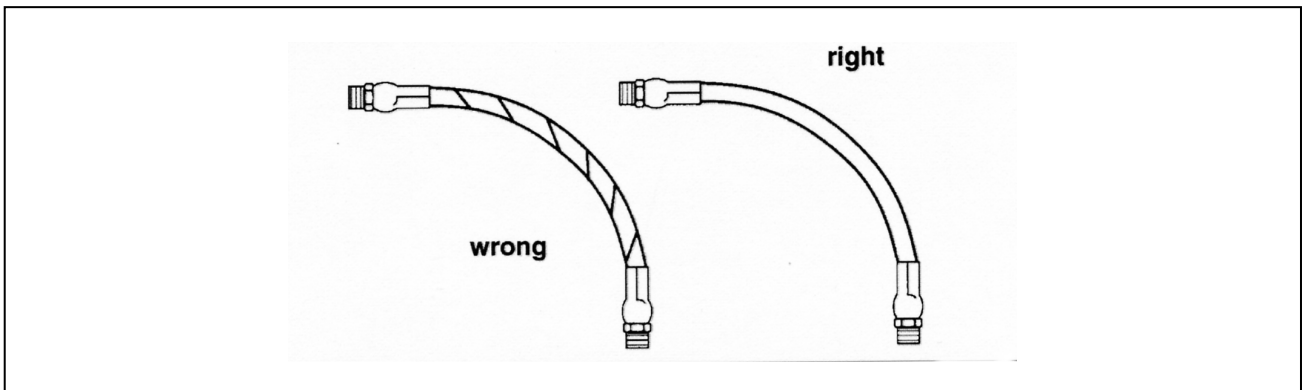

- Always check the black protective sleeve is in good order, to replace sleeve is far cheaper than replacing expensive hoses.
- Hose warranty is limited to replacement of hoses due to faulty materials or manufacture Warranty will not be considered on hoses damaged by chafing, abrasion, cuts or pinching while in work, or to damaged threads due to over tightening.
- All hose connections are of a “Parker” soft seal type and only need 1/2 a turn more than finger tight to become leak-proof.

# Spearhead TWIGA PRO

---

## Oil Supply

- Daily before starting up check oil level in tank reservoir.
- It is a good practice to constantly keep an eye on the tank level gauge, (this can be seen from the tractor seat) as a pipe burst could empty the tank within minutes.
- A pump or motor starved of oil will be damaged beyond repair.
- Replace oil if signs of contamination occur (discoloured)
- Contamination can be reduced by:
  - Thoroughly cleaning around reservoir cap before removing.
  - Using a clean container when replenishing the system.
  - Regularly servicing the filtration system.
  - Never allowing oil level to fall below the sight gauge.
- Daily inspect all hydraulic connections and fittings to be in good order. Any damage or leaks must be rectified immediately, this is part of the daily maintenance and is your responsibility, to maintain a long reliable working life.
- When tightening fittings always use two spanners when necessary and do not over tighten. If a fitting leaks it will need to be replaced.

## Filtration Maintenance

The machine is protected by a suction strainer and a low pressure full flow return line filter.

1. The suction filter is permanently fixed in the reservoir tank. Should symptoms of pump cavitations or spongy operation occurs, the tank must be drained, the tank and suction filter thoroughly cleaned and dried before refilling with clean oil.
2. The return line element should be replaced after the first 50 hours and thereafter at 300 hour intervals. It is most important to replace the filter within these intervals because once blocked, oil will bypass the filter element infiltrated.
3. When tightening fittings always use two spanners when necessary and do not over tighten. If a fitting leaks it will need to be replaced.

# Spearhead TWIGA PRO

---

## Pins & Bushes

All main pivot points are furnished with replaceable bushes. If there are any signs of wear, these must be replaced. All bushes are available from Spearhead Parts Department.

### Warning

Do not use grease containing Molybdenum disulphide on nylon bushes and wear pads.

## Storage

Remember regular maintenance will greatly increase the life of the machine.

Before storing away, thoroughly wash the machine removing all traces of grass and dirt. Care must be taken when washing with high-pressure hoses, do not hold the water jet close to the paintwork. Use steam cleaners with caution, be sure to remove all detergents to avoid any discolouring or damage to paint. Grease all grease points until fresh grease shows. It is important where possible to store undercover to protect against rain and sunlight. Always ensure a firm level surface.

Smear greaser on all areas vulnerable to corrosion, in particular the chrome on the ramrods.

Before you attempt to do any repairs, service, maintenance or adjustment on your machine, ensure the engine has stopped and the key removed. P.T.O. is disengaged, handbrake secure, and the head is firmly on the ground.

Control levers must be wrapped in plastic sheeting and taped over to keep dry.

PROPILOT controls should be removed and stored in a safe and dry area.

# Spearhead TWIGA PRO

## Regular Services Chart

Service Hours	Service points	Grease	Drain	Check	Clean	Change
1-4 hrs	Bolts are fully tightened			X		
	Condition of flails			X		
	Condition of hoses especially for chafing			X		
	Flail bolts are fully tightened			X		
	Flail head retaining bolts are fully tightened			X		
	Gearbox seals (If oil is leaking replace immediately)			X		( X )
	Inspect leaks from fittings and pipes			X		
	Pins and bushes			X		
	Rotor bearing bolts are fully tightened			X		
8 hrs	Bearings	X				
	Gearbox & pump bolts are fully tightened			X		
	Gearbox oil level			X		
	Grease points & PTO shaft	X				
	Motor Drive	X				
	Maintain correct belt tension on head (only with belt drive heads)			X		
	Oil level in reservoir	X		X		
	U.J. joints					
50 hrs	Gearbox oil (use EP 90 oil)		X			X
250-300 hrs	Return line filter element					X
	Hydraulic oil if any signs of contamination appears		X	X		

## Pump & Motor Failure Prevention

- Never run out of oil.
- Never run a cold machine straight up to speed, first ensure engine revolutions are low then engage/disengage the head motor.
- Never increase or decrease engine speed quickly.
- Never stop or start rotor at high engine speed.
- Never transport with P.T.O. in gear.
- Regularly check condition of suction line hose.
- Never operate above recommended P.T.O. speed.
- Check that pump fittings are tight.
- If any strange noise occurs from the hydraulics, stop immediately and investigate.
- Remember, pump and motor warranty is limited to replacement due to faulty materials or manufacturer. Cavitations and peak pressures are very easily detected on pump inspection.
- Warranty will not be considered if fault is due to misuse.
- Never cause severe sudden movements to arms. Pressure will peak and will transmit back to pump, resulting in failure.



# Spearhead TWIGA PRO

## Trouble Shooting

Problem	Cause	Solution
Gearbox overheating	Oil level incorrect	Check oil level
	Oil grade incorrect	Check oil grade
	Implement overloaded	Reduce forward speed
Excessive belt wear	Wrong PTO speed	Ensure tractor PTO speed matches implement
	Belt and pulley condition	Replace if necessary
	Pulley alignment	Check alignment
	Incorrect belt tension	Tension belts to spec
P.T.O.. wear U.J. failure	Overloading of implement	Reduce forward speed or increase height of cut
	Working angle to great	Reduce offset of implements
	Shaft incorrect length I.e. bottoming out	Resize PTO shaft as recommended
Cut Quality	Lack of maintenance	Grease PTO shaft as recommended
	Flails worn	Replace worn flails
	Rotor speed/direction	Check tractor PTO speed
Rotor bearing failure	Crop condition	Look for suitable conditions
	Rotor out of balance	See rotor vibration
	Wire/string in bearing	Remove wire/string
	Lack of maintenance	Grease bearings to schedule
Rotor vibration	Water in bearing	Expel water with grease
	Flails broken or missing	Replace flails
	Bearings worn or damaged	Replace bearings
	Rotor bend	Re-balance/replace rotor
Oil tank overheating	Build up of debris	Remove debris
	Incorrect speed	Check rotor R.P.M.
	Oil level incorrect	Fill tank to correct level
	Oil grade incorrect	Drain and refill tank with correct grade oil
	PTO speed too fast	Ensure the tractor's PTO speed matches implement
Break-back operating Frequently	Ambient temperature too high	Reduce work rate / install oil cooler
	Machine overloaded	Reduce forward speed or increase height of cut
	Machine being used on excessive incline	Switch off auto reset
	Weight of machine being carried upon rear roller	Use Autopilot or head float
Hydraulics not responding	Machine not set vertical	Shorten top link
	Oil level low	Fill oil to correct level
	Oil pump suction filter blocked	Replace filter element
	Oil leak in pressure line	Check machine of leaks
Joystick control sluggish	Drive line broken	Check pump is rotating
	Air in pilot lines from joystick	Slacken off each line of pilot circuit individually at spool valve whilst operating. When all air is expelled retighten the line

# Spearhead TWIGA PRO

## Trouble Shooting

Problem	Cause	Solution
Irregular arm movement	Spool contacting with housing	Check spool is free moving
	Broken spring in spool valve	Check spring
	Failed ram seals	Repair ram
Electrically operated valve not responding	Faulty wiring	Check wiring and switches
	Dirt in valve	Check of ingress of dirt
	Sticking valve	Replace the valve
	Insufficient voltage	Attend to bad connection

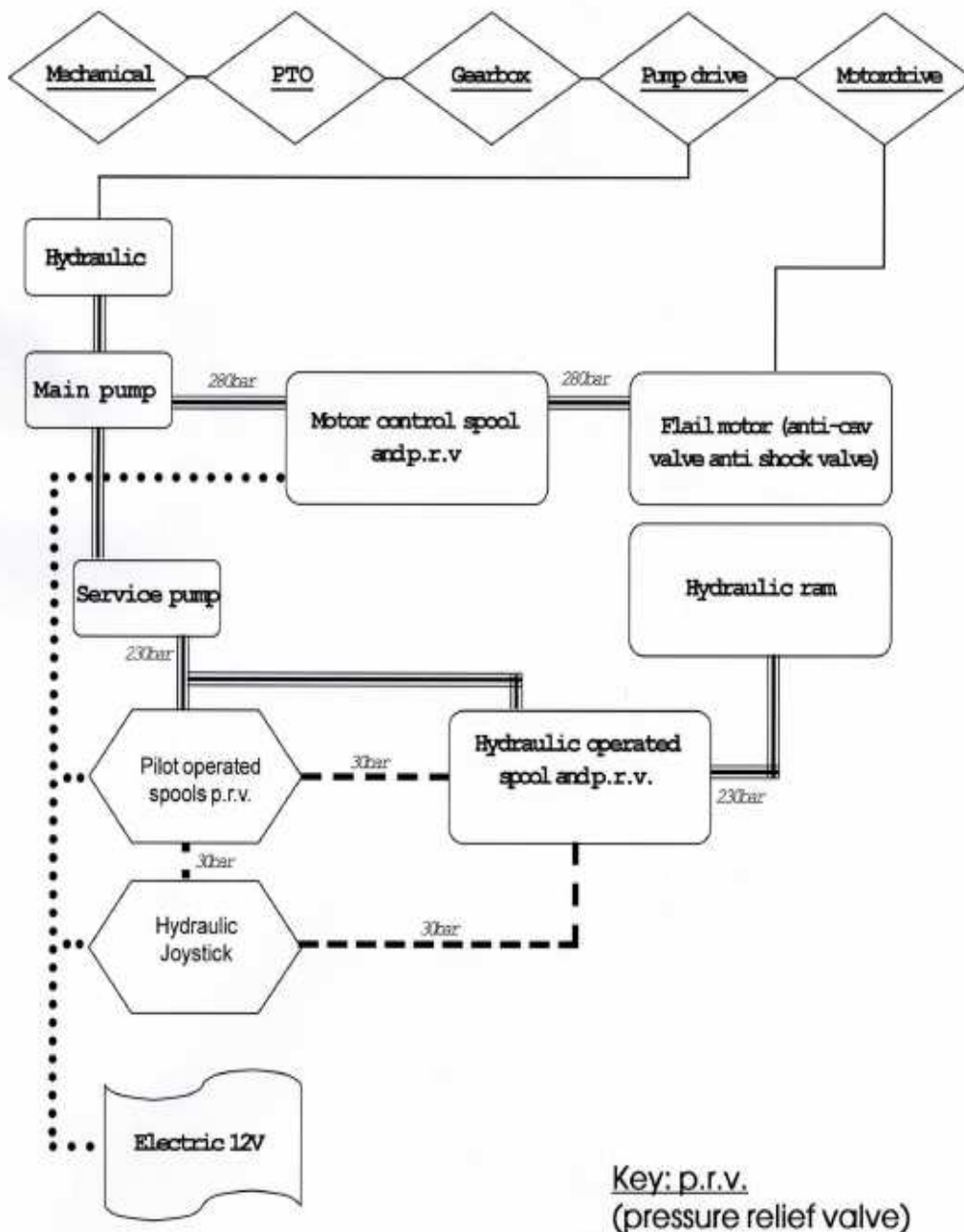





Spearhead Machinery Ltd  
Green View  
Salford Priors  
Evesham  
Worcestershire  
WR11 8SW  
Tel: 01789 491860  
Fax: 01789 778683  
[www.spearheadmachinery.com](http://www.spearheadmachinery.com)  
[enquiries@spearheadmachinery.com](mailto:enquiries@spearheadmachinery.com)