

Spearhead

Swipe

€150/ €180/€210



Edition 1.0 – April 2009
Part No. 8999069

HANDBOOK



Swipe

€150/€180/€210

Handbook

1.0 Edition – April 2009

Please ensure that this manual is handed to the operator before using the machine for the first time. The operator must fully understand the contents of this manual before using this machine.

Important Note

The information contained in this manual is correct at the time of publication. However, in the course of constant development, changes in specification are inevitable. Should you find the information given in this book different to the machine it relates to please contact the "After Sales Department" for advice.

Spearhead Machinery Ltd

Green View

Salford Priors

Evesham

Worcestershire

WR11 8SW

Tel: 01789 491860

Fax: 01789 778683

www.spearheadmachinery.com

enquiries@spearheadmachinery.com

CE Declaration of Conformity, Conforming to EU Machinery Directive 2006/42/EC

We, Spearhead Machinery Ltd, Green View, Salford Priors,
Evesham, Worcestershire, WR11 8SW hereby declare that:

Product.....

Product Code.....

Serial No.....

Type.....

Manufactured by: Alamo Manufacturing Services (UK) Limited, Station Road,
Salford Priors, Evesham, Worcestershire, WR11 8SW

Complies with the required provisions of the Machinery Directive 2006/42/EC.
The Machinery Directive is supported by the following harmonized standards:

- BS EN ISO 14121-1 (2007) Safety of Machinery – Risk Assessment, Part 1: Principles Part 2: Practical Guide and Examples of Methods.
- BS EN ISO 12100-1 (2010) Safety of Machinery – Part 1: Basic Terminology and Methodology Part 2: Technical Principles.
- BS EN 349 (1993) + A1 (2008) Safety of Machinery – Minimum Distances to avoid the Entrapment of Human Body Parts.
- BS EN 953 (1998) Safety of Machinery – Guards General Requirements for the Design and Construction of Fixed and Movable Guards.
- BS EN 982 (1996) + A1 (2008) Safety Requirements for Fluid Power Systems and their Components. Hydraulics.

The EC Declaration only applies if the machine stated above is used in accordance with the operating instructions.



Signed

(On behalf of Spearhead Machinery Ltd)

Status

General Manager

Date

.....

CONTENTS

General Information	5
Machine Description	6
Machine Identification	6
Technical Specifications	6
Component Identification	7
Safety Information	8
Safety Decal Identification	10
Safety Decal Locations	11
Pre-Installation	12
Fitting Machine To The Tractor	14
PTO Shaft Installation	15
Initial Run Up	16
Transport	18
General Operation	18
Maintenance	20
Machine Removal & Storage	21
Troubleshooting	22
Warranty	23

GENERAL INFORMATION

Always read this manual before fitting or operating the machine – whenever any doubt exists contact your dealer or the Spearhead Machinery Service Department for advice and assistance.

Use only Spearhead Machinery Genuine Service Parts on Spearhead Machinery Equipment and Machines

DEFINITIONS – The following definitions apply throughout this manual:

WARNING

An operating procedure, technique etc, which – can result in personal injury or loss of life if not observed carefully.

CAUTION

An operating procedure, technique etc, which – can result in damage to either machine or equipment if not observed carefully.

NOTE

An operating procedure, technique etc, which – is considered essential to emphasis.

LEFT & RIGHT HAND

This term is applicable to the machine when attached to the tractor and is viewed from the rear – this also applies to tractor references.

MACHINE DESCRIPTION & PURPOSE OF USE

The SP Range of machines are '3-point linkage' tractor mounted rotary mowers ideal for the cutting of grass, weeds and pasture materials of up to 25mm (1") diameter. The flexible 3-point hitch design allows the mower to follow the contours of the ground for optimum cutting performance with minimum stress on the machine and tractor. A rear tail wheel with puncture proof tyre is fitted as standard for control of cutting height. Machines are suitable for tractors of 15HP and over with 540RPM PTO speed.

These machines should only be used to perform tasks for which they were designed – use of the machine for any other function may be both dangerous to persons and damaging to components and is therefore not advisable.

MACHINE IDENTIFICATION

Each machine is fitted with an identification plate with the following information:

1. Machine (Part Number)
2. Machine Serial No.
3. Machine Weight

When ordering spares or replacement parts from your local dealer it is important to quote both the Part Number and the Serial Number as stated on the identification plate so the machine and model can be quickly and correctly identified.

TECHNICAL SPECIFICATIONS

Specifications	SP- 5 model	SP- 6 model
Working Width	1.50m (4'9")	1.80m (5'9")
Transport Width	1.60m (5'2")	1.93m (6'3")
Length	2.46m (8')	2.69m (8'8")
Weight	300kg	430kg
Cutting Height	25-150mm	19-150mm
Cutting Capacity	25mm	25mm
Power (min.)	20HP	30HP
Gearbox protection	Slip clutch	Slip clutch
Guards	Front / Rear	Front / Rear
Tail Wheel	Laminated	Laminated
PTO Type	Independent	Independent
PTO Speed	540 rev/min	540 rev/min
PTO Size	1.3/8" (6 spline)	1.3/8" (6 spline)

Spearhead Swipe €150/€180/€210

COMPONENT IDENTIFICATION

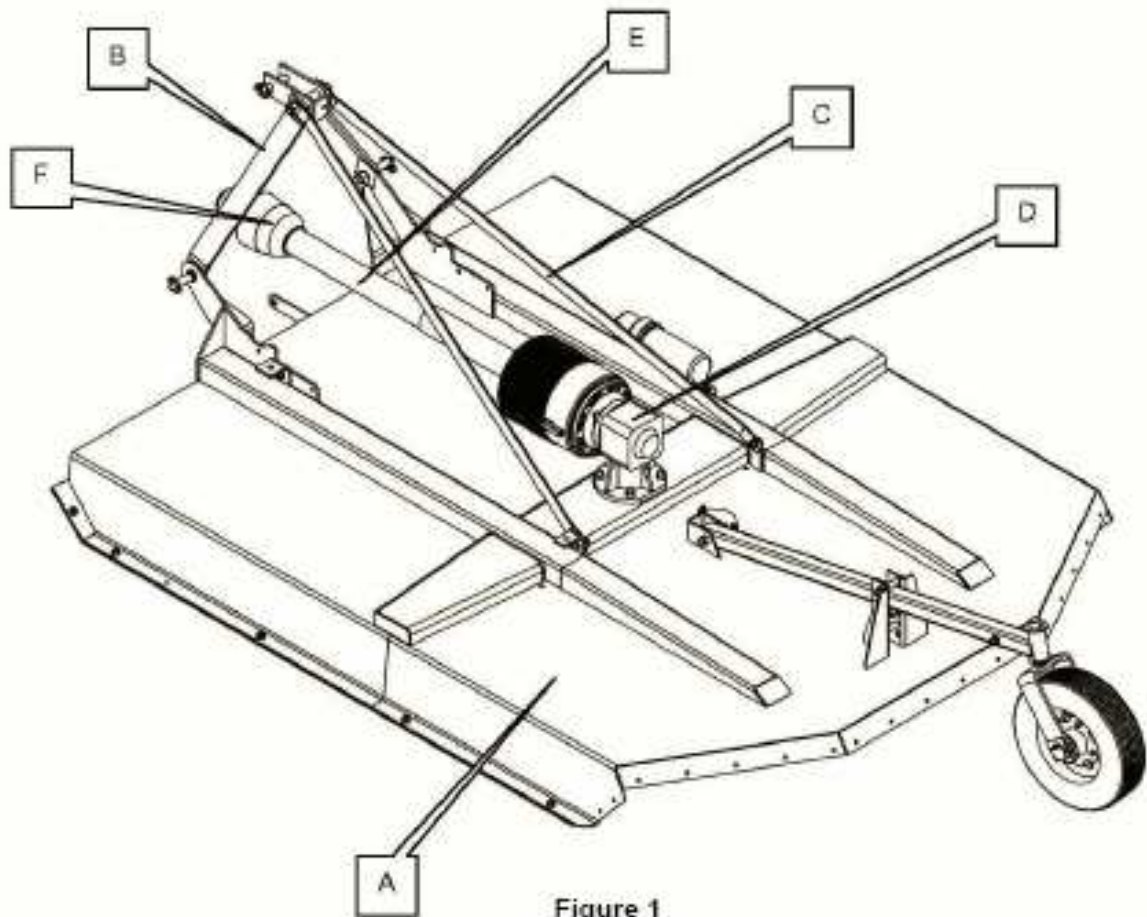

Figure 1

- A) DECK
- B) A-FRAME
- C) A-FRAME STAYS
- D) GEARBOX
- E) PTO SHAFT
- F) PTO COVER

SAFETY INFORMATION

General Safety Rules:

- ▲ Always read and follow the instructions for the use and maintenance of the machine before carrying out any work operations or servicing tasks.
- ▲ Improper use of the machine is both highly dangerous to persons and damaging to the machine components – only use the machine for its designated task.
- ▲ Both operators and the maintenance fitters should be familiar with the machine and fully aware of dangers surrounding improper use or incorrect repairs.
- ▲ Before starting, checks to both tractor and machine must be carried out as regards: functionality, road safety, accident prevention rules.
- ▲ Even when using the machine correctly, stones or other objects may be thrown a long distance. Therefore nobody must stand within the danger area. Special attention must be paid when working near roads or buildings.
- ▲ Use tractor's fitted with safety cabs.
- ▲ The condition of blades and of machine guards must be checked before beginning the daily work - they must be replaced if damaged or missing before you use the machine.
- ▲ During checks or repairs, make sure nobody could start the machine by mistake.
- ▲ Never wear loose or fluttering clothes.
- ▲ Never carry passengers on the tractor.
- ▲ Never carry passengers on the machine.
- ▲ Never connect the power takeoff with the engine running.
- ▲ Never approach the machine until the rotor has completely stopped.
- ▲ Do not enter the working zone of the PTO shaft. It is dangerous to approach the rotating parts of a machine.
- ▲ Keep the PTO shaft guard in good condition.
- ▲ Before starting, check the surrounding area for the likely presence of children and/or animals.
- ▲ Do not stand near the machine when it is operating.
- ▲ The PTO shaft must be assembled and disassembled only with the engine stopped and the starting key removed.
- ▲ Before connecting the power takeoff, check that the speed and the rotational direction correspond to those of the machine.
- ▲ Immediately replace missing or damaged safety decals.
- ▲ Before leaving the tractor with the machine attached, proceed as follows:
 1. Disconnect the power takeoff,
 2. Put the machine steadily on the ground using the tractor's hydraulic lift.
 3. Apply the hand brake and, if the ground is steeply sloping, wedge the tractor with wheel chocks.
 4. Remove the starting key.

Transportation Safety

- ▲ In transport, reduce speed, especially on bumpy roads, the weight of the machine may render driving difficult and damage the machine itself.
- ▲ Ensure the levers that operate the hydraulic lift are locked, to avoid the lowering of the machine during transport.
- ▲ When driving on public roads, respect all road rules in force.
- ▲ Never transport the machine with the rotor running, even for short distances.

Operating Safety

- ▲ Pay special attention when working with the machine not to contact fixed objects as this could cause damage to machine components resulting in parts or debris being thrown out of the machine at very high speed.
- ▲ If wires, ropes or chains should become entangled in the rotor stop immediately to prevent damage or dangerous situations; stop the rotor and the tractor, take out the starting key. Put working gloves on; clear the rotor with the aid of pliers or shears. Do not try to disentangle by inverting the rotational direction of the rotor.
- ▲ Do not use the machine when excessive vibration is experienced, as this may cause breakage and serious damage - find the cause of the vibration and eliminate it before using the machine again.

Although the information given here covers a wide range of safety subjects, it is impossible to predict every eventuality that can occur under differing circumstances whilst operating this machine. No advice given here can replace 'good common sense' and 'total awareness' at all times, but will go a long way towards the safe use of your Spearhead machine.

SAFETY DECAL IDENTIFICATION

Safety decals are located on various points of the machine. They can be identified by the yellow upper panel depicting the hazard, and the lower white panel indicating means of avoidance or precautions to be taken. These decals have no text. It is essential that all operators and personnel associated with the machine fully understand their meanings, which are shown below. Any safety decals which are found missing should be replaced.

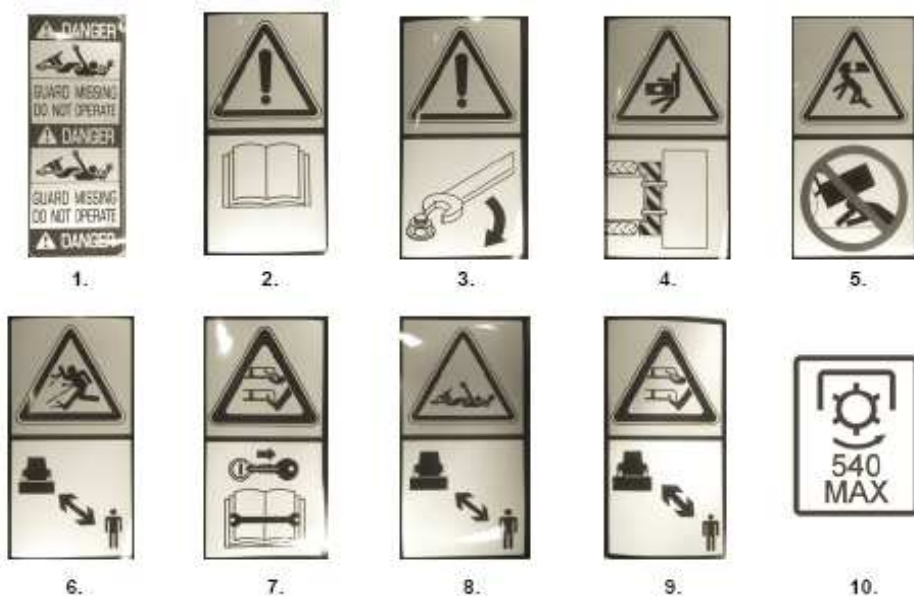

- 1. Driveline Guard Missing** - Ensure PTO guard is fitted to the machine before operating.
- 2. Read Instructions** - Always fully read and understand the instructions before using the machine.
- 3. Keep Nuts Tight** - Ensure all nuts and bolts are tight before commencing work with the machine.
- 4. Keep Out Zone** - Keep at a safe distance from the machine to avoid being crushed.
- 5. Unsupported Machine** - Do not attempt to get underneath the machine because of the risk of fall.
- 6. Thrown Debris** - Keep at a safety distance from the machine to avoid the risk of debris being thrown from the machine.
- 7. Rotating Blades Danger** - Remove the ignition key and read the instructions before working on or getting close to the machine, as the blades may still be rotating.
- 8. Shaft Entanglement** - Keep at a safe distance from the machine to avoid being caught in guarding, rotor shaft, or the PTO shaft.
- 9. Unblock Rotor Head** - Ensure rotary head has come to a complete stop before attempting to unblock the blades.
- 10. Max PTO Speed 540 ACW** - PTO speed not to exceed 540 RPM anti-clockwise.

Spearhead Swipe €150/€180/€210

SAFETY DECAL LOCATIONS

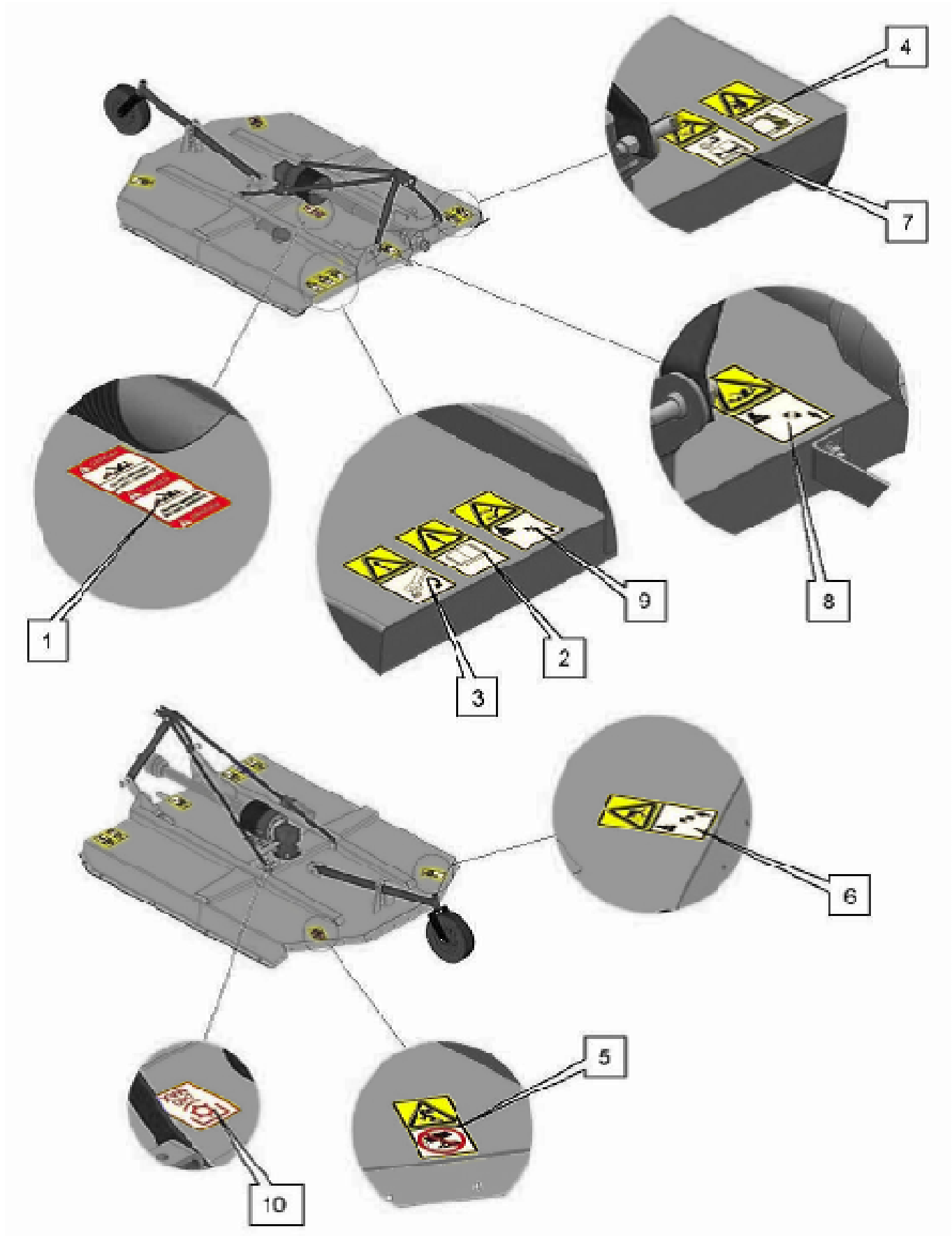

Figure 2

Spearhead Swipe €150/€180/€210

PRE-INSTALLATION

Tractor Requirements

Ensure the specifications of the tractor meet the requirements listed below:

- The PTO is 6 spline of 1.3/8" diameter.
- The PTO output is 540 rev/min.
- The three-point linkage is Category one/two.

Tractor Preparation

- Remove any brackets or objects which may obstruct operation of lift arms.
- Disengage PTO drive and expose PTO drive shaft.

Machine Preparation

Machines will normally be delivered fully assembled, with the exception of certain occasions or export markets where the machine may be partially dismantled for ease of transportation;

in these cases minor re-assembly will be required in order to return the machine to a working state – see *below*:

- Unbolt the wheel beam from the two transport brackets securing the wheel beam to the deck at locations indicated (1) & (2) (*Fig.3*).

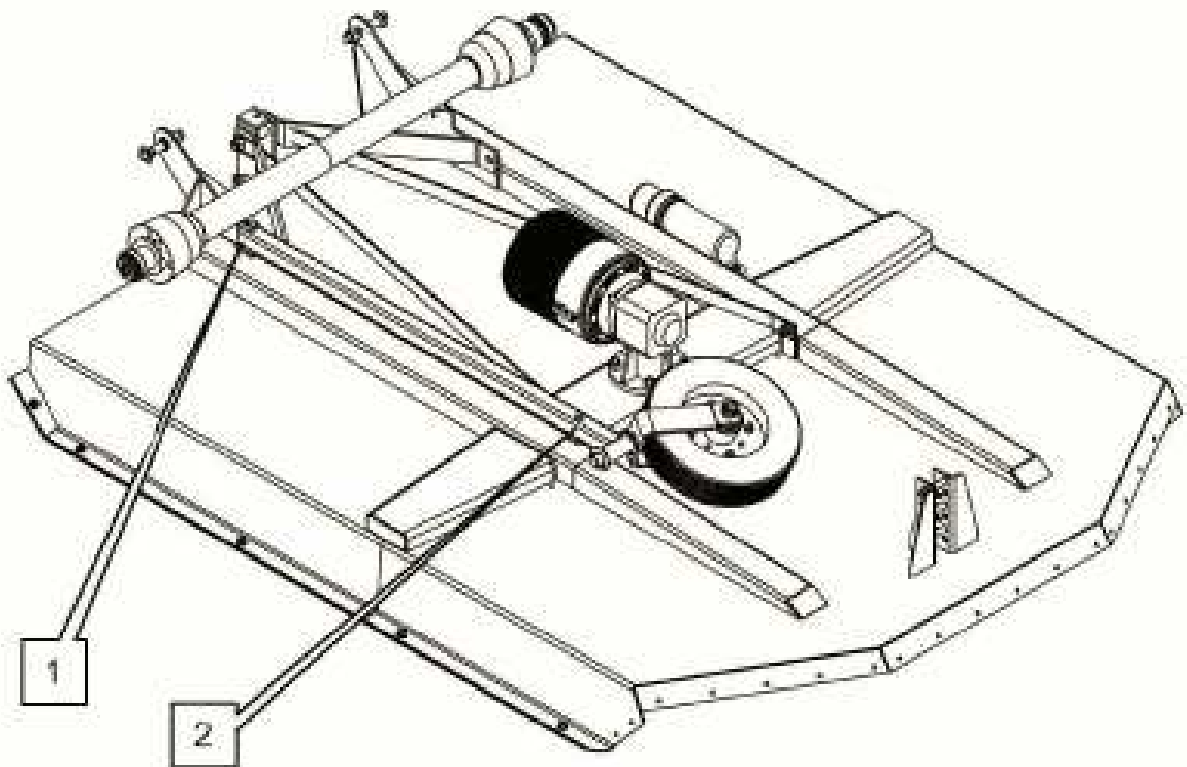
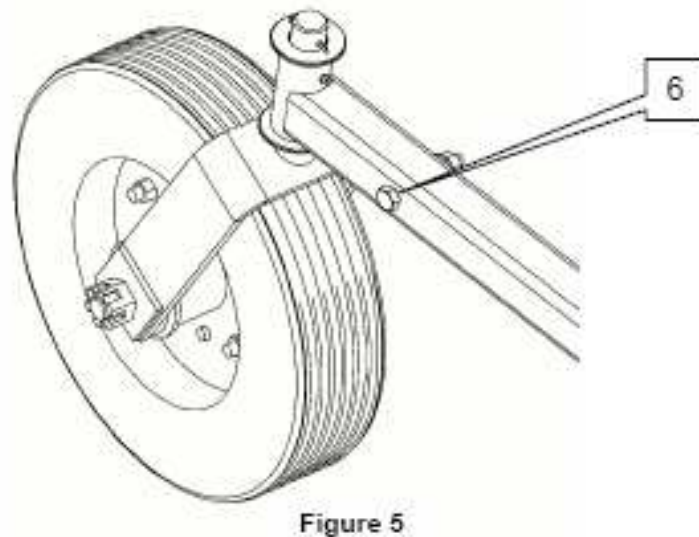
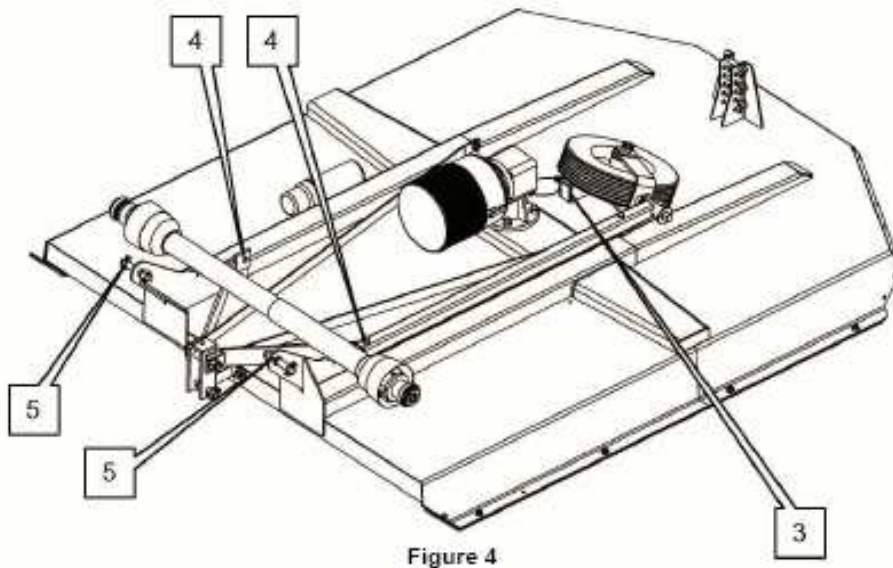

Figure 3

Spearhead Swipe €150/€180/€210

- Assemble the wheel beam in its working position on the deck by fastening bolt (1) (*Fig.3*) to bracket (3) on the deck (*Fig.4*).
- Fasten nut and bolt (2) (*Fig.3*) into wheel beam assembly location (6) (*Fig.5*).
- Unfasten cable ties holding lower links arms in place, positions (4) (*Fig.4*) and secure lower links in place using lower link pins in positions (5) (*Fig.4*)
- Ensure all fasteners are securely tightened. The machine is then in its working position.



FITTING MACHINE TO THE TRACTOR

Attachment of the machine to the tractor should always be performed on a firm level site.

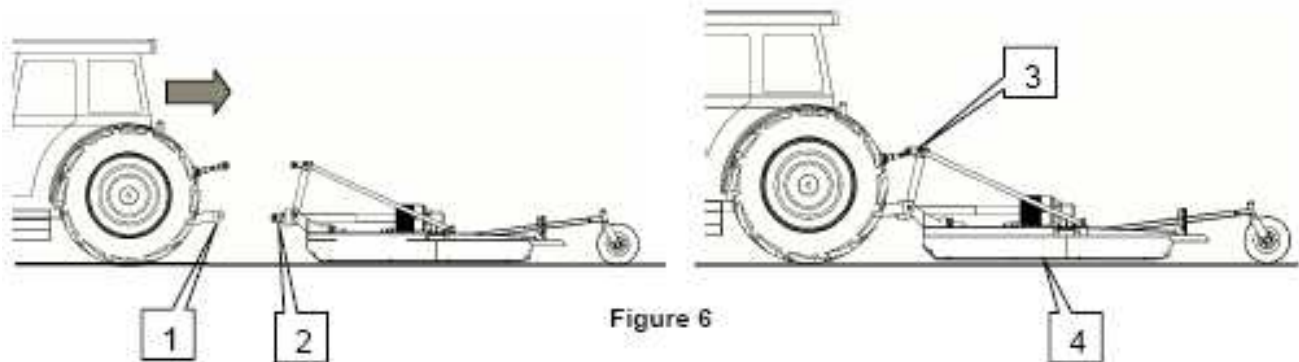

The procedure for fitting the machine to the tractor is as follows:

- Disengage the PTO drive.
- Reverse tractor squarely to the machine (*Fig.6*).
- Gradually reverse tractor until lift arm holes (1) are level with mounting pins (2).
- Fit left lift arm into mounting pin.
- Adjust height of right lift arm if necessary.
- Fit right arm on to the mounting pin then lock with lynch pin.
- Fit top stay of machine to top link on tractor (3), adjusting the length with the machine level on the skids (4)
- Secure with pins provided with tractor.
- Adjust lift arm check chains to prevent machine from swaying when raised.
- Fit PTO shaft – *for first time attachment to a tractor refer to following page for details regarding measurement and cutting of a PTO shaft.*

PTO SHAFT INSTALLATION

PTO Shaft Measurement

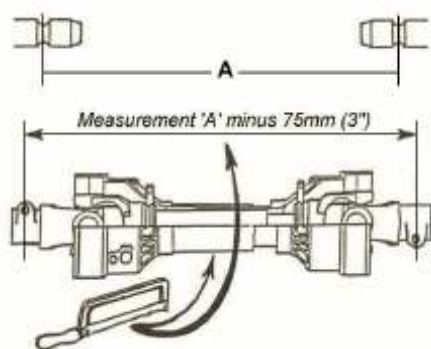

Figure 7

Measure the PTO shaft and cut to the dimension shown (Fig.7) – the finished length of the PTO shaft should be 75mm (3”) less than the measured distance ‘A’ - between tractor shaft and gearbox stub shaft - to enable fitting.

NOTE:

For subsequent use with different tractors measure again, there must be a minimum shaft overlap of 150mm (6”). Fit PTO in position and attach the torque chains to a convenient location to prevent the shaft guards from rotating.

PTO Shaft Length Adjustment

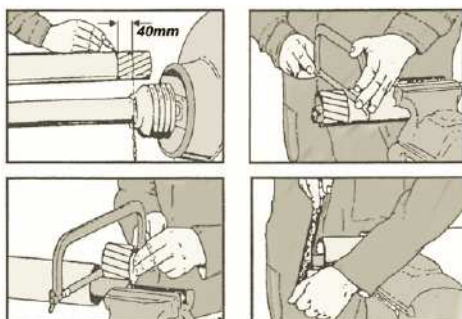

1. Shorten outer plastic tube to 40mm less than the shortest envisaged shaft length as illustrated (Fig.8).
2. Remove the marked tube.
3. Remove same length from inner plastic tube and metal shaft profiles (inner and outer).
4. De-burr all edges and remove ‘swarf’ to ensure smooth operation.

PTO Fitment

- Before fitting PTO shaft to tractor, grease the sliding drive shafts and bearing units.
- Fit PTO to tractor ensuring locking peg on the splined coupling is fully engaged.
- Attach PTO guard torque chains to tractor and machine.

Pre-Operational Checks

Before commencing work with the machine the following checks should be performed:

- Make a visual inspection of the machine to ensure it is in good operational condition.
- Check all safety guarding is in position and in full working order.
- Check for missing or damaged components and replace if required.
- Check all greasing points are well lubricated.
- Check gearbox oil level.
- Check PTO speed and direction match that of the machine.

INITIAL RUN UP

- Raise the machine off ground using tractor hydraulics (*Fig.9*).
- Ensure nobody is standing near to the machine.
- Run tractor engine at idle speed and engage PTO drive.
- When rotor starts increase PTO speed gradually to 540 rev/min.
- If rotor fails to start stop tractor engine and check PTO drive.
- Allow the machine to run for approximately ten minutes.

Stop the machine immediately if excessive noise is heard or vibration is felt, and refer to section on 'Maintenance'.

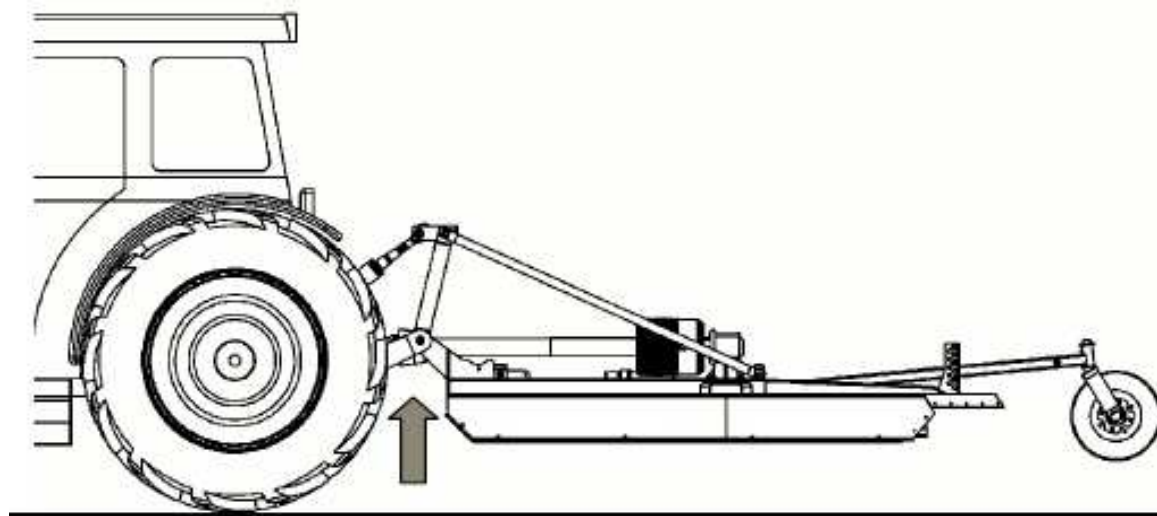

Pre-Work Lubrication Checks

Gearbox: The gearbox is filled with semi-fluid grease prior to leaving the factory, but it is advisable to check the level before putting the machine to work, this is performed by removal of the level plug situated on the rear of the gearbox. Warm the gearbox up before filling to the correct level with EP90 lubricant.

Grease Points: All grease points should be greased before operating the machine – *refer to maintenance section for details.*

Parking

When parking or storing the machine it should always be placed on firm level ground for protection of the machine and safety to persons.

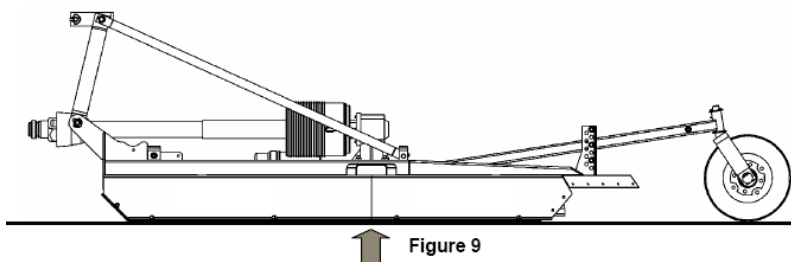

Safety Guards

It is vital that in the interests of safety all guards (*Fig.10*) must be kept in position on both the machine and the tractor whenever the machine is running or operating.

The manufacturer disclaims all responsibility for damage or injury arising as a result of machine guards being removed, altered, or the use of guards other than those provided by the manufacturer being fitted to the machine.

ALWAYS: Check that all guards are fitted correctly and are in good working condition.

ALWAYS: Inspect guards frequently and replace any guards that have wear or damage which is likely to impair their operation.

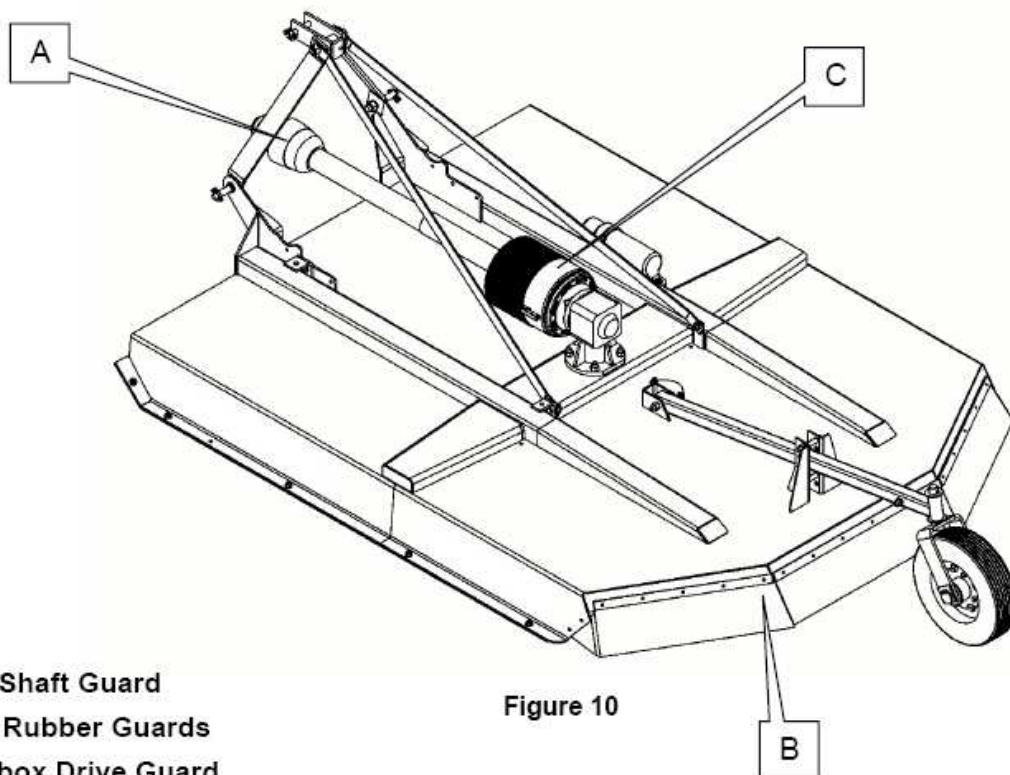

TRANSPORT

Normally the machine will need to be driven to the work site. To put machine into the transport position follow the instructions stated below:

- Raise machine from the ground using tractor hydraulics.
- Lock in raised position.
- Do not transport with PTO speed drive engaged.

GENERAL OPERATION

Initial Checks

Check that the tractor is equipped to deliver 540 rev/min at the power take-off shaft.

UNDER NO CIRCUMSTANCES MUST THE PTO EXCEED 540 REV/MIN.

Normal Pre-Start Checks

- Check that the rotor is free from obstructions, especially pieces of wire.
- Check that all blades are in good condition and securely attached.
- Check that all guards are in position and that they are in good condition.
- Examine the job to be cut. It is very important that the work site is inspected before cutting and all hidden obstructions removed or their positions marked so that they can be avoided.
- Check for wire, hidden stakes, drain pipes, large stones, etc. and remove or mark their location.

Normal Run Up

- With a new machine never start cutting in arduous conditions, allow for at least one day's light work for running-in.
- Never attempt to start the machine while it is under load at any time. Always free rotor shaft from any obstructions.
- Never increase or decrease PTO speed rapidly as this can lead to gearbox damage.
- Never engage PTO at full 540 PTO speed.
- Disengage the PTO when lifting the machine at headlands.



WARNING!

Stop the machine immediately if excessive noise is detected from the rotor or gearbox and investigate the cause – ensure the machine has stopped fully, the tractor engine switched off and the key removed before approaching the machine. Do not use the machine again until the problem has been rectified.

- Keep PTO speed at 540-550 rev/min to maintain rotor shaft speed.

Spearhead Swipe €150/€180/€210

- AVOID wire. **Stop the tractor engine immediately** if an unusual noise is heard from the machine. On no account raise or move the cutting unit until the rotor has stopped.

Never under any circumstances run the rotor 'to clear' itself.

- AVOID stumps and pipes etc. Stalling in heavy growth may cause damage to the rotor.
- DO NOT allow personnel near the machine while it is operating.
- AVOID rushing into material when operating.
- AVOID taking in too much material by selecting an appropriate forward speed.

Stalling the Rotor

If the rotor does become choked the tractor will stall or the PTO clutch will slip. If this should occur follow the instructions below:

- Stop forward motion, disengage PTO drive immediately and place PTO drive lever in neutral.
- Lift the machine using tractor hydraulics.
- Stop the tractor engine.
- Remove any obstructions that may be present on the rotor. If working under the raised machine ensure that it is safely supported.
- **Never under any circumstances** run the rotor 'to clear' itself.

Cutting Height

The height of cut can be adjusted by altering the position of the castor wheel arm within the multi-position clevis on the main deck (Fig. 11).

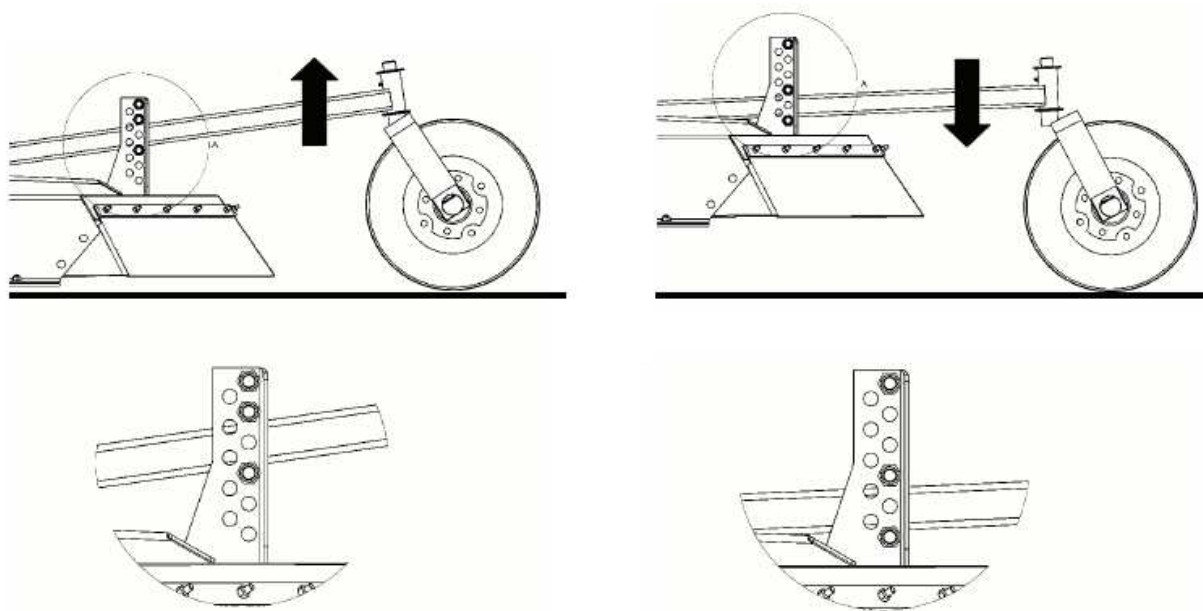

MAINTENANCE

Power Takeoff Shaft (PTO)

The PTO shaft used is of the normal agricultural type. Spares kits, comprising the spider, needle bearings, circlips etc., are generally available from most agricultural dealers.

For correct part numbers refer to the parts manual for the specific machine.

Some routine maintenance is needed to ensure a trouble free life for the PTO shaft. For best results follow instructions below:

- Regularly grease the PTO shaft sliding tubes.
- Grease both ends of PTO shaft on a daily basis during use.
- Ensure PTO guard torque chains are securely attached and in good condition.
- Check that PTO guard is in good condition – replace immediately if damaged.
- Check universal joint bearing journals for roughness or slack - replace if necessary.

Slip Clutch

A slip clutch is incorporated in the PTO driveline. It is designed to slip, absorb the shock load, and protect the driveline.

Clutch torque setting is factory set. If the clutch slips excessively the friction discs should be checked for excessive wear. Discs are 1/8" (3.2mm) thick when new - replace after 1/32" (0.8mm) wear.

If the slip clutch has a compression spring check length of springs as assembled on clutch; the length should be 1.5/16" (33.3mm) - if not adjust length of bolt to obtain the correct spring length. If additional adjustment is required tighten each bolt 1/2 turn.

NOTE: *Do not tighten spring bolts over 1/2 turn at any adjustment - excessive tightening can cause clutch to become frozen and not slip which could cause damage to tractor PTO, drivelines or gearbox. Clutches that have not been used for 30 days should be slackened off, run for a second and re-tightened to above settings.*

Lubrication

The lubrication chart below states the frequency at which grease points should be lubricated:

Grease Point	Frequency
PTO Shaft Bearings	Weekly
PTO Shaft Tubes	Weekly
Castor Wheel	Weekly

Do not over grease - this can cause overheating and damage bearing seals.

Rotors

Vibration of the rotor can cause premature failure of the rotor shaft bearings as well as structural failures. It is vital that the machine **is not** operated with the rotor vibrating - if any vibration is detected stop operating the machine immediately and carry out the checks listed below:

- Stop tractor engine, neutralise PTO drive and remove the starting key.
- Check for missing or damaged blades - replace any missing components immediately.
- Check and ensure that all blade attachments are tight. If any blade components are missing or loose and have been replaced and tightened, run the rotor and test for signs of vibration - if vibration is still present, check as follows:
 - Stop tractor engine, neutralise PTO drive and remove the starting key.
 - Check rotor gearbox bearings for roughness or signs of slackness.
 - Replace bearings which suffer the above symptoms. If vibration persists it is an indication that the rotor is probably bent and must therefore be replaced before using the machine again.

MACHINE REMOVAL & STORAGE

In the parking position the machine rests on the skids at both sides. To put the machine in this position the following procedure is necessary:

- Remove the bolt from the height adjusting clevis on the main deck to allow the castor arm to swing up.
- Lower the machine to the ground using the tractor hydraulics.
- Stop tractor engine and disengage PTO drive.
- Slacken lift arm and check chains.
- Remove top link.
- Remove lynch pin and rings securing lift arms to mounting pins.
- Remove mounting pins from mounting clevis and lift arms.
- Grease mounting pins.
- Replace lynch pins.
- Release tractor end of PTO shaft and pull back along splines.
- Start tractor engine and drive carefully forward.
- Grease spline and tubes of PTO and store with the machine or keep in a safe dry place.

Machine Storage

Before removing the machine from the tractor a thorough check of the machine and its components should be made. Follow instructions below.

- Thoroughly clean all moving parts, particularly the rotors.

Spearhead Swipe €150/€180/€210

- Check that all blades are in place and that they are in good condition.
- Smear all unpainted metal parts with grease and lubricate all grease nipples.
- Make a note of any item that needs replacing so that parts can be ordered.

Disposal

At the end of the machines working life all the parts that may cause danger have to be made inert. The materials forming the machine have to undergo a differentiated division, these materials are:

- ▲ Steel (Deck, 'A' Frame, Blades etc.)
- ▲ Mineral Oil (within Gearbox)
- ▲ Rubber (Rear Guarding)
- ▲ Plastic (PTO Guarding)

All the above mentioned operations and the disposal have to be carried out in total respect of the present provisions of law on the subject.

TROUBLESHOOTING

Troubleshooting Chart

Problem	Suggested cause	Remedy
Irregular Cut	<i>Worn, bent or broken blades. Machine is not level with the ground. Material blockage due to speed.</i>	<i>Replace item(s). Level the machine. Reduce working speed.</i>
Machine Noise	<i>Loose bolts. Cracks or initiation of cracks in deck.</i>	<i>Tighten Bolts. Have it repaired in specialised workshop.</i>
Gearbox noise	<i>Lack of oil. Worn bearings. Worn gears.</i>	<i>Fill to level. Replace. Replace.</i>
Vibration	<i>Broken or worn blades. Unbalanced rotor.</i>	<i>Replace. Replace in authorised workshop.</i>
Premature blade wear	<i>Blades contacting the ground.</i>	<i>Adjust the height of cut.</i>
Excessive backlash in joints	<i>Worn pins</i>	<i>Replace</i>

The Spearhead Warranty

Spearhead warrants that the Spearhead machine referred to in the Warranty Registration Form will be free from defects in materials and workmanship for a period of 12 months from the date of sale. This warranty does not affect your statutory rights, but merely adds to them. Should you have a problem within 12 months from the date of sale please contact your original Spearhead dealer, or Spearhead's Service Department. Any part found to be defective during this period will be replaced or repaired, at Spearhead's discretion, by the dealer or a Spearhead Service Engineer.

Spearhead Warranty Conditions

1. The Warranty Registration Form must be completed and returned to Spearhead within 30 days of the date of sale
2. This warranty does not cover defects arising from fair wear and tear, willful damage, negligence, misuse, abnormal working conditions, use in competition, failure to follow Spearhead's instructions (oral or written, including all instructions and recommendation made in the Operator's Manual) or alteration or repair of the machinery without Spearhead's approval.
3. The machinery must have been serviced in accordance with the Operator's Manual and the Service Log must have been kept up to date and made available to the dealer should service, repair or warranty work be undertaken.
4. This warranty does not cover claims in respect of wearing parts such as blades, flails, paintwork, tyres, belts, hydraulic hoses, bearings, bushes, linkage pins, top links, ball ends unless there is a manufacturing or material defect or the cost of normal servicing items such as oils and lubricants.
5. This warranty does not cover any expenses or losses incurred whilst the machinery is out of use for warranty repairs or parts replacement.
6. This warranty does not extend to parts, materials or equipment not manufactured by Spearhead, for which the Buyer shall only be entitled to the benefit of any such warranty or guarantee given by the manufacturer to Spearhead. Only genuine Spearhead replacement parts will be allowable for warranty claims.
7. All parts replaced by Spearhead under warranty become the property of Spearhead and must be returned to Spearhead if Spearhead so request. Such parts may only be disposed of after a warranty claim has been accepted and processed by Spearhead.
8. Spearhead is not liable under this warranty for any repairs carried out without Spearhead's written consent or without Spearhead being afforded a reasonable opportunity to inspect the machinery the subject of the warranty claim. Spearhead's written consent must, therefore, be obtained before any repairs are carried out or parts replaced. Use of non- Spearhead parts automatically invalidates the Spearhead Warranty. Failed components must not be dismantled except as specifically authorised by Spearhead and dismantling of any components without authorisation from Spearhead will invalidate this warranty.
9. All warranty claims must be submitted to Spearhead on Spearhead Warranty Claim Forms within 30 days of completion of warranty work.

Using the machine implies the knowledge and acceptance of these instructions and the limitations contained in this Manual.

Extended Warranty

As an extension to the 12-month warranty set out above, Spearhead will provide an additional 12-month warranty cover subject to the Spearhead Warranty Conditions above and the Extended Warranty Conditions below.

Extended Warranty Conditions

1. The extended warranty applies to hydraulic pumps, motors, valves and gearboxes only. It does not apply to other parts, to consumables such as lubricants, seals or filters or to labour charges.
2. The machinery must have had an annual service carried out by an Authorized Spearhead Dealer or a Spearhead Service Engineer within 1 month of the first anniversary of the date of sale and the Service Report form must have been completed and stamped by the servicing dealer or Spearhead Service Engineer and sent to Spearhead within 14 days after the first annual service.
3. The extended warranty does not cover costs of transportation of the machinery to or from the dealer or Spearhead or the call out costs or traveling expenses of on-site visits

Transfer of Warranty

The Spearhead warranty may be transferred to a subsequent owner of the machinery (for use within the UK) for the balance of the warranty period subject to all of the warranty conditions and provided that the Change of Owner form is completed and sent to Spearhead within 14 days of change of ownership.

Spearhead reserves the right to make alterations and improvements to any machinery without notification and without obligation to do so.

Spearhead Machinery

Green View,

Salford Priors,

Evesham,

Worcestershire,

WR11 8SW

Tel: 01789 491860

Fax: 01789 778683

www.spearheadmachinery.com

enquiries@spearheadmachinery.com