

# Spearhead

## MULTICUT 420



Edition 1.0 – April 2007  
Part No. 8999022

## HANDBOOK



## Multi-Cut 420

### Handbook

1.0 Edition – April 2007

Please ensure that this manual is handed to the operator before using the machine for the first time. The operator must fully understand the contents of this manual before using this machine.  
(If the machine is resold the Manual must be given to the new owner.)

#### Important Note

The information contained in this manual is correct at the time of publication. However, in the course of constant development, changes in specification are inevitable. Should you find the information given in this book different to the machine it relates to please contact the "After Sales Department" for advice.

Spearhead Machinery  
Green View  
Salford Priors  
Evesham  
Worcestershire  
WR11 8SW  
Tel: 01789 491860  
Fax: 01789 778683  
[www.spearheadmachinery.com](http://www.spearheadmachinery.com)  
[enquiries@spearheadmachinery.com](mailto:enquiries@spearheadmachinery.com)

© Spearhead Machinery Limited 2007

# Spearhead Multi-Cut 420

---

## CE Declaration of Conformity, Conforming to EU Machinery Directive 2006/42/EC

We, Spearhead Machinery Ltd, Green View, Salford Priors,  
Evesham, Worcestershire, WR11 8SW hereby declare that:

*Product*.....  
*Product Code*.....  
*Serial No.*.....  
*Type*.....

Manufactured by: Alamo Manufacturing Services (UK) Limited, Station  
Road, Salford Priors, Evesham, Worcestershire, WR11 8SW

Complies with the required provisions of the Machinery Directive  
2006/42/EC. The Machinery Directive is supported by the following  
harmonized standards:

- BS EN ISO 14121-1 (2007) Safety of Machinery – Risk Assessment,  
Part 1: Principles Part 2: Practical Guide and Examples of Methods.
- BS EN ISO 12100-1 (2010) Safety of Machinery – Part 1: Basic  
Terminology and Methodology Part 2: Technical Principles.
- BS EN 349 (1993) + A1 (2008) Safety of Machinery – Minimum  
Distances to avoid the Entrapment of Human Body Parts.
- BS EN 953 (1998) Safety of Machinery – Guards General  
Requirements for the Design and Construction of Fixed and Movable  
Guards.
- BS EN 982 (1996) + A1 (2008) Safety Requirements for Fluid Power  
Systems and their Components. Hydraulics.

The EC Declaration only applies if the machine stated above is used in  
accordance with the operating instructions.

*Signed*



(On behalf of Spearhead Machinery Ltd)

*Status*

General Manager

*Date*

.....

# Spearhead Multi-Cut 420

---

## Contents

Contents	4
Safety	5
Recommendations	6
Introduction	8
Tractor Requirements	8
Attaching to the Tractor	8/9
Setting up your Machine	10
Operation	11
Transportation	12
Machine protection	13

## Servicing & Maintenance

Safety First	14
Daily	15
Every 8 Hours	16
Torque Settings	16
Regularly	17
Blades	17
Slip Clutch Settings	18
Skids	19
Wheels	19
Storage	20
Trouble Shooting Guide	21
Warranty	22

# Spearhead Multi-Cut 420

## Safety



**Warning**  
Avoid fluid escaping under pressure. Consult technical manual for services procedures.



**Warning**  
Danger – flying objects keep safe distance from the machine as long as the engine is running.



**Warning**  
Stay clear of mower blade as long as engine is running.



**Warning**  
Stay clear of swinging area of implements.



**Warning**  
Shut off engine and remove key before performing maintenance or repair work.



**Warning**  
Check all nuts are tight every 8 hours.



**Warning**  
Carefully read operator's manual before handling this machine. Observe instructions and safety rules when operating.

# Spearhead Multi-Cut 420

---

## Recommendations

### **Beware of the following Potential Dangers associated with the use of this machine:**

- Becoming trapped when hitching or unhitching
- Machine overbalancing when wing is raised.
- Getting caught on rotating power take off (PTO)
- Being hit or caught by any moving part, e.g. Blades, drive shaft and wings.
- Being hit by flying debris or machine parts due to machine damage
- Machine overbalancing when not in use
- Injection of high pressure oil from damaged couplings or hydraulic hoses
- Accidents due to collision with other machines, or debris left on road
- Beware of free-swinging blades over centering and falling when wings are folding.

### **ALWAYS:**

- Ensure the operator has read this handbook and has been trained to use the machine.
- Ensure all safety guards are in place and all tractor windows closed.
- Impact resistant shielding to the tractor is recommended
- Before leaving the tractor cab always ensure that the wings are firmly on the ground, no weight is on the machine's hydraulics and the rotor has stopped spinning.
- Check that all guards are properly fitted and there are no damaged or loose parts. Particular attention should be given to the blades to ensure they are not damaged, cracked or missing.
- Inspect work area for wire, steel posts, large stones and other dangerous materials and remove before starting work.
- Ensure that all warning labels are always visible and that they are not damaged, defaced or missing.
- Fit locking bars to height and to wings before transport and before unhitching when applicable.
- Wear ear defenders if operating without a quiet cab or with the cab windows open
- Ensure tractor guards are fitted correctly and are undamaged
- Work at a safe speed, taking into account terrain, passing vehicles and obstacles
- Ensure that the tractor meets the minimum weight recommendations of the machine manufacturer and that ballast is used if necessary
- Check that machine fittings and couplings are in good condition
- Follow the manufacturer's instructions for attachment and removal of machine from the tractor
- Ensure blades are of the type recommended by the manufacturer, are securely fitted and are undamaged
- Ensure hydraulic pipes are correctly routed to avoid damage from chafing, stretching, pinching or kinking.
- Check condition of tyres and tightness of wheel nuts.
- Ensure all blades have stopped spinning before folding wings into transport position.

# Spearhead Multi-Cut 420

---

- Disengage the machine, stop the engine and remove the key before leaving the tractor cab for any reason
- Clean up any debris left at the work site.
- Ensure that when you remove the machine from the tractor it is secured in a safe position using the stands provided, on level concrete base.

## **NEVER:**

- Never operate the machine with other people present, as it is possible for debris, including stones, to be discharged from the front and rear.
- Never operate the machine until you have read and understood this handbook and are familiar with the controls.
- Never use a machine that is poorly maintained or has guards that are damaged or missing
- Never allow an inexperienced person to operate the machine without supervision.
- Never use or fit a machine onto a tractor if it doesn't meet the manufacturer's specification.
- Never use a machine if the hydraulic system shows signs of damage.
- Never attempt to detect a hydraulic leak with your hand, use a piece of card.
- Never allow children to play on or around the machine at any time.
- Never attempt any maintenance or adjustment without first disengaging the PTO, lowering the wings to the ground, stopping the tractor engine and applying the tractor parking brake.
- Never leave the cab without removing the ignition key.
- Never operate the tractor or any controls from any position other than from the driving seat.
- Never stop the engine with the PTO engaged.
- Never operate with blades missing.
- Never operate PTO above recommended speed, 1000 r.p.m.
- Never operate with wire around the rotor. Stop immediately.
- Never use the wing raised which may throw debris towards the cab.
- Never attempt to use the machine for any purpose other than that it was designed for.
- Never transport with the PTO engaged.
- Never enter the working area of the machine (risk of injury!).
- Never engage the P.T.O with wings folded.

# Spearhead Multi-Cut 420

---

## Introduction

The Spearhead 420 is a heavy-duty rotary mower for a set-aside, stubble and pasture topping. By carefully following the instructions in this handbook, the 420 will give many years of trouble free operation.

## Safety First

Never start using the machine until the handbook has been read and understood. The 420 rotary mower is a potentially lethal machine if used incorrectly and it is essential that the operator fully understand the working before starting up.

## Tractor Requirements

- Spearhead recommend tractors of between 85 and 120hp.
- Category 2 three-point linkage.
- Stabilisers or check chains must be in good working order to hold the machine firmly. Do not operate without ensuring the check chains or stabilisers are tight. Spearhead particularly recommend “turnbuckle” type check chains.
- Set tractor lift rods of equal length.
- Before hitching, ensure position control is selected. Do not attempt to hitch in draft control.
- Ensure there is sufficient weight on front wheels of the tractor for safe transport and stability. The tractor should have a minimum weight of 3700 kg.
- The tractor should have a 1000rpm P.T.O.
- One external hydraulic service required, single acting with float facility for wings.

## Attaching To The Tractor

Fit the machine to the tractor in the standard way, ensuring the correct match of linkage (*category 2*). Check that the top link is in good order and the threads are well lubricated. Use stabilisers to eliminate any sideways sway.

Before lifting the machine with the tractor linkage you should ensure there is sufficient front weight to keep the front wheels in contact with ground. This is most important for safe transport and stability when turning on sloping ground.

It is essential to ensure that the tractor drawbar cannot foul the P.T.O. shaft, we advise to remove it altogether if there is any doubt.

Before fitting the PTO for the first time, it may be necessary to adjust the length. There should be maximum engagement of the sliding tubes without bottoming at the shortest operation position. To check, first connect the mower to the tractor. Pull the PTO shaft apart and connect to the tractor PTO output shaft and the gearbox input shaft. Hold the half shafts next to each other in the shortest working position. If necessary, shorten the inner and outer guard tubes equally (Fig. 1). Shorten the inner and outer sliding profiles by the same length as the guard tubes. File all sharp edges and remove burrs. Grease sliding profiles.



# Spearhead Multi-Cut 420

**Fig.1 Shortening the PTO drive shaft**



**a** Check shaft tube surplus length.



**b** Cut surplus length from shaft tubes. File sharp edges and remove burrs.

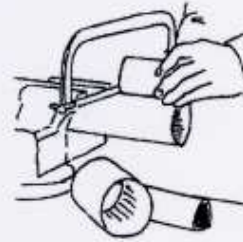

**c** Shorten shield tubes to the same length. Grease inner shaft tube and install shield.

Before fitting the PTO, first clean and grease. Remove the clamp bolts on the yoke and slide onto the machine gearbox, refit the bolts into the groove tighten 150Nm. Pull back the PTO release ring and slide onto tractor stub shaft until it engages.

The PTO shaft is fitted with a non-rotating safety guard. It should be secured to the machine and tractor with the two retaining chains provided.

Connect the hydraulic hose, to a single acting service, with a dump facility. This is important so the wings can follow the ground contours in work.

Connect the top link and adjust to ensure there is some slack in the wire ropes, before raising the machine.

Raise the parking stands and secure locking pin.

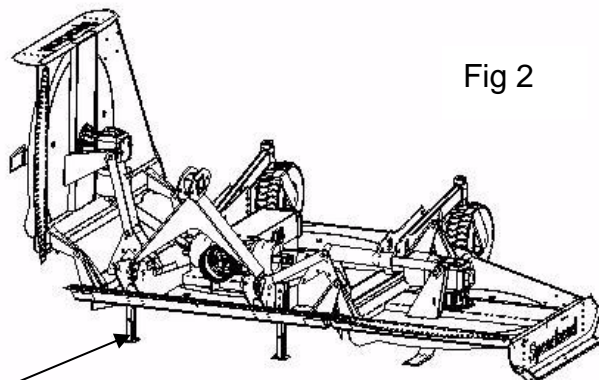

Parking stands

# Spearhead Multi-Cut 420

## Setting Up Your Machine

### Height

To alter the height of cut; raise the machine so the wheels are clear of the ground, remove pin **a** (Fig. 3) adjust the wheel arm, replace pin **a** (Fig 3) and gently lower the machine until the wheel contacts the ground. Fine adjustment can be made by moving the spacers on the wheel fork above or below the wheel arm, spacer **b** (Fig 3). Now adjust the height of the tractor link arms so the front of the mower is 25mm (1") higher at the front **c**.

The top link must be adjusted to ensure the wire ropes are slack, so the machine can follow undulating ground fore and aft, but still allow the machine to lift when the tractor link arms are fully raised.

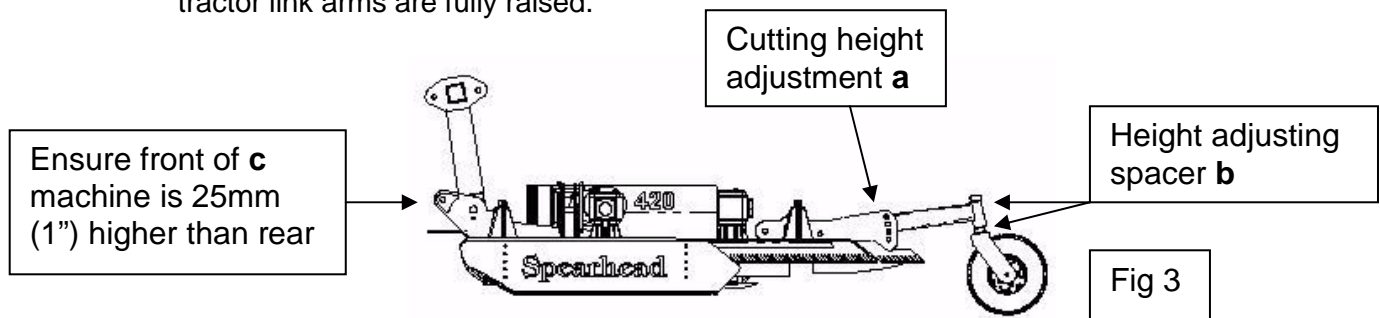

### Wings

Unfolding the wings if the machine is in the transport position, first pressurise hydraulic rams before releasing locking bar (Fig 4), lower both wings by releasing hydraulic pressure, leaving tractor spool in float position (Fig, 5).

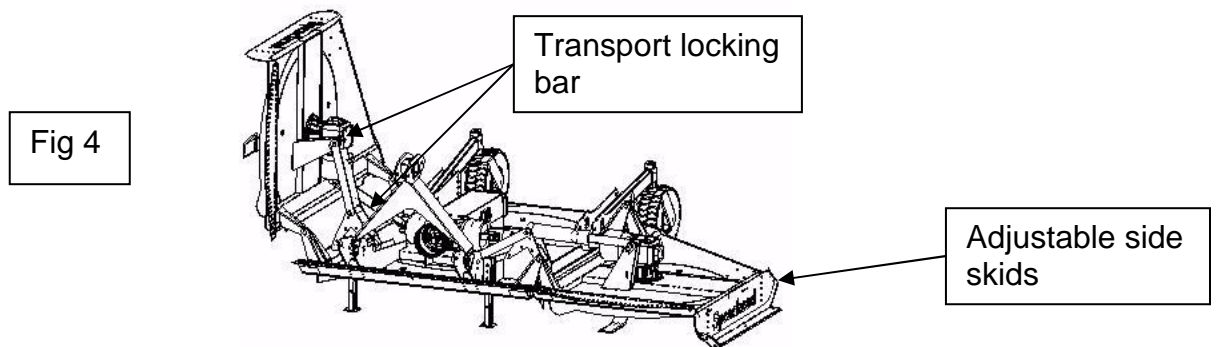

### Levelling the wing cutting height LH & RH

With the wings lowered, adjustable skids alter cutting height, these should be set to maintain minimum cutting height 12mm (1/2") above the centre blades. When fitted with optional wheels to the wings, the skids should be raised above the ground and the cutting height controlled by the height of these wheels.

#### Note

To achieve a level cut with the wing wheels, they need to set lower than the centre wheels.

# Spearhead Multi-Cut 420

---

## Operation

Once ready for work with the wings unfolded, raise the mower clear of the ground and slowly engage the PTO with the tractor engine at low revs to prevent shock damage to the machine. Slowly increase the engine revs to achieve the recommended PTO speed of 1000r.p.m. As indicated by the decal on top of the centre guard and not the number of splines on the P.T.O shaft. Lower the machine onto the ground, select a sensible forward speed bearing in mind the density of growth, the terrain, the available horsepower and proceed. If at any time serious vibration occurs, **stop the engine immediately and check the blades, following all safety precautions.**

The quality of finish is determined by the forward speed, i.e. a slow speed will produce a high quality of cut, where as faster forward speeds are used when high output is first priority.

When in work, always ensure the hydraulic spool valve that operates the folding of the wings is in float position to enable the wings to freely follow all contours of ground (Fig. 5).

**Fig. 5 contours of the ground**

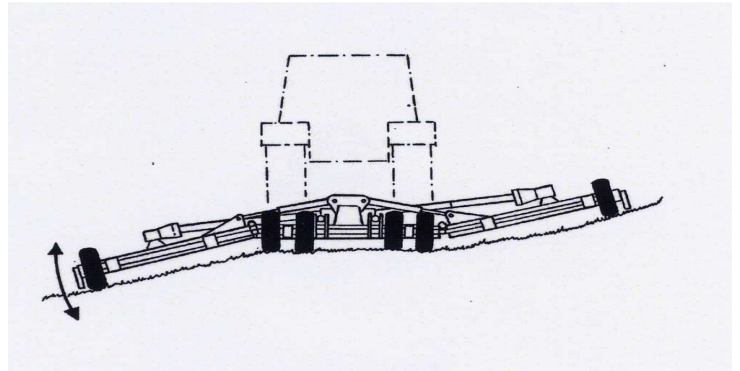

Whilst mowing it is possible to continue working when turning the 420 Rotary Cutter on the headlands, however we recommend the machine is slightly raised to prevent the skids marking the ground and reduce the wear on the skids.

When operating in confined areas it is possible to cut going backwards, but it is advisable to slightly raise the machine, particularly if in scrub, where there is the risk of hitting hidden solid obstacles obscured by dense undergrowth.

Always exercise particular care when operating over uneven ground surfaces. Do not allow the blades and blade holder to frequently hit the ground.

Do not allow debris to build upon the cutting decks in dry conditions, as this can be a fire hazard, in wet conditions it will place unnecessary strain on the machine and may foul the drive shaft causing damage.

# Spearhead Multi-Cut 420



## Warning

Do not run the machine with the wings raised, serious damage will result to the drive line.

## Options

- An extra two wheels are available for the wings to improve contour following on uneven ground and reduce wear on the skids.
- Three blades per rotor (standard 2) to improve cutting and mulching.
- Lighting kit.

## Transportation

First disengage the PTO drive and half raise the machine, fold the wings fully upright and secure rams with locking bar (Fig. 6). **Never** transport along public highways with the wings only supported by the hydraulics.

Please observe Public Highway Regulations, concerning the towing of implements, and securely attach a registration and lighting board.



## Warning

Avoid transporting machine at high speed over rough ground  
Maximum speed on highway – 20mph (30kph).

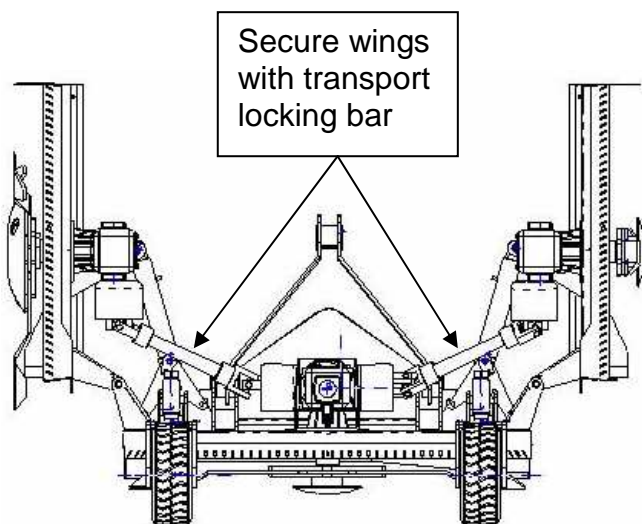

Fig. 6

Transportation position

# Spearhead Multi-Cut 420

---

## Machine Protection

To prevent gearbox damage all rotors are protected by slip clutches fitted to each of the three rotor gearboxes. When cutting in extreme conditions where stumps, rocks and other such solid objects are likely to be found it is recommended that the operator reduces the engine revs to allow the blades to pivot more easily when striking solid objects, and proceed with caution.

The clutch settings should not be altered without reference to Service and Maintenance. Never over-tighten the pressure springs on the slip clutches (Fig. 7) as this could result in severe damage to the gearbox and drive lines, as well as invalidating the warranty.

**If the machine has been laid up for any length of time, there is a risk of the clutch plates rusting and seizing together. Never operate the machine in this condition**, as there will be no protection to the driveline and gearboxes against shock loading. To free the clutch plates first slacken all pressure spring bolts and run up the machine for a short period, deliberately try to cause the clutch to slip. Finally re-tighten the tension spring bolts to their original length, taking great care not to over-tighten. Alternatively refer to page 17.

If in any doubt, consult Spearhead's Service Department or your local Spearhead Dealer for further advice.

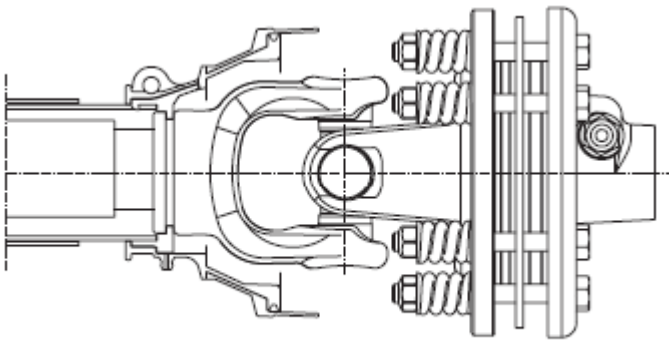

Fig. 7 Slip Clutch

# Spearhead Multi-Cut 420

---



## Warning

Never carry out any servicing or maintenance work without first disengaging the PTO and then stopping the tractor engine before leaving the seat.

On delivery of your machine check that the dealer has completed the P.D.I form, ensure the warranty registration form is completed and returned.

## Service & Maintenance

### Safety First

- Never leave the tractor seat without first disengaging the PTO and stopping the engine.
- Ensure all rotating parts have stopped turning.
- Never attempt any repairs, maintenance, service or any other checks with the machine carried on the tractor hydraulics.
- Always fully lower to the ground, or securely prop the machine on substantial servicing stands.
- Always replace all guards and retaining chains after servicing/maintenance completed.

It is imperative that the following checks are carried out in order not to invalidate your warranty; these are carried out **before the first operation, after the first hour, then after 4 hours.**

### **These checks are:**

1. Wheel nuts and tyre pressure (40psi).
2. Gearbox bolts, including the splitter box.
3. Retaining bolts on the drive shafts.
4. Grease all points including drive shaft tubes.
5. **After the first 50 hours drain and replace the gearbox lubrication.** Replace with liquid grease (NLGI 000).
6. All other nuts and bolts

# Spearhead Multi-Cut 420

## Servicing & Maintenance

### Daily

- Grease all points.
- Check bolts are tight on all gearboxes.
- Check condition of blades and blade bushes; ensure all retaining bolts are fully tight.
- Check wheel nuts are tight.
- Check tyre pressures – 40 P.S.I.
- Check gearbox lubrication, replenish as necessary to the correct level line on the dipstick, provided with each gearbox.

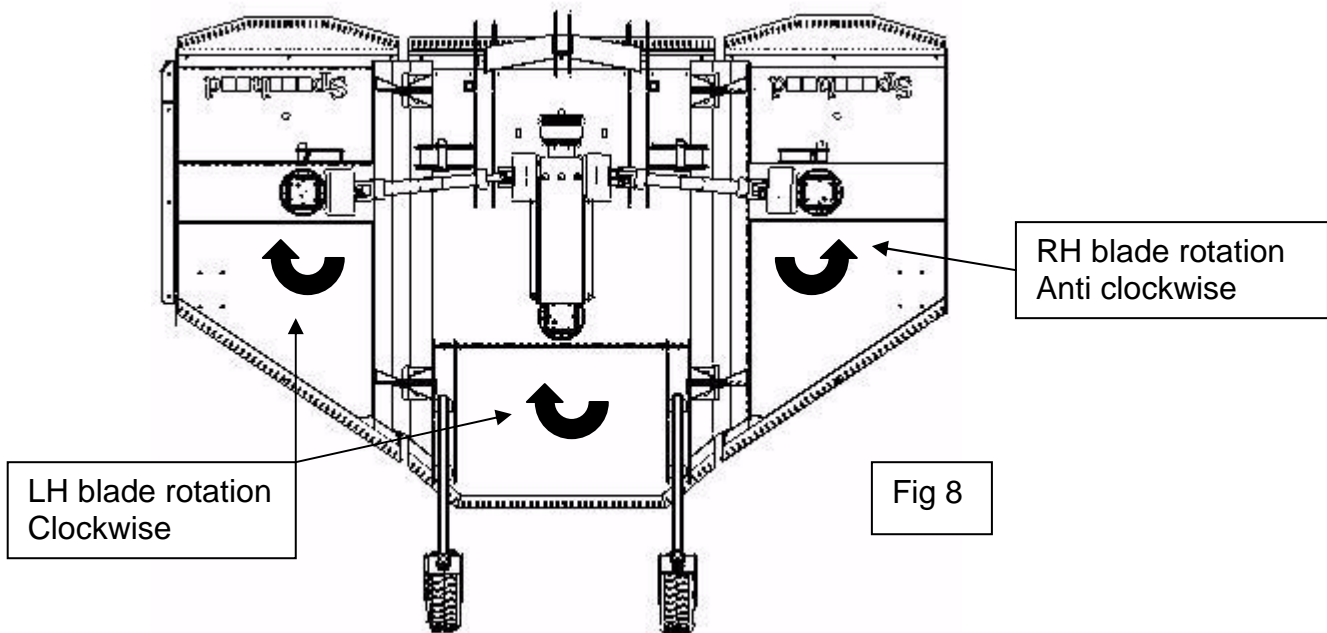

**Fig. 8** Lubrication points

- A Wing rams
- B Wheel stem grease points
- C Wheel bearings
- D Wing hinges
- E Input PTO shaft
- F Wing PTO shafts
- G Centre PTO coupling
- H Headstock

# Spearhead Multi-Cut 420

## Service & Maintenance – Every 8 hours

### Primary Input Shaft

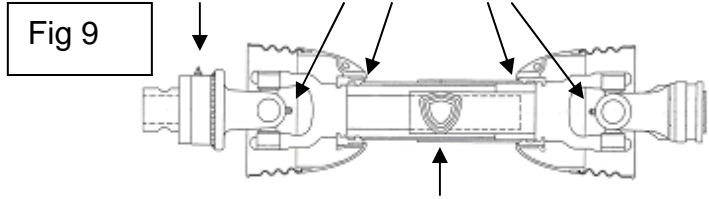

- For maximum life and performance, the UJ must be greased regularly. Lubricate the driveline up to 6 pumps of grease may be required.
- The metal drive tubes must be greased to telescope properly.
- Shielding is subject to damage from abuse and weathering. Replace all damaged components and all shielding removed during maintenance.
- Do not use PTO adapters drivelines. Replace special clamp bolts only with genuine OEM parts, periodically check tightness of nuts.

- Dismantle and clean the main P.T.O shafts sliding surfaces and re-grease; failure to do this will result in serious damage to the gearboxes.
- Grease all universal joints, if under-greased this joint will soon fail.
- Grease the wing drive shaft tubes.
- Lubricate the retaining collar on all the drive shaft guards (Fig. 9).
- Grease PTO inner tube and push pins (Fig. 9).
- Check all bolts are tightened to the correct Torque (Fig.10).

## Torque Settings

Fig 10

The Torque figures given below are recommended maximum settings only.

Size:	Tensile strength:	Description:	Torque setting: Nm.
M16	8.8	Rotor gearbox bolts	280
¾ UNC	8.8	Splitter gearbox	280
M24	8.8	Blade bolts	950
		Wheel nuts	270
M14		PTO clamp bolt	150



# Spearhead Multi-Cut 420

---

## Servicing & Maintenance

### Regularly

- Check there is no wrapping of string, plastic, grass or other debris between rotor boss and gearbox oil seal.
- Inspect gearbox seals for leaks.
- Clear grass and other debris from the deck.
- Regularly check the rotor boss retaining castle nut for tightness. First remove the split pin, select the correct size socket in 3/4" drive and fully tighten the nut. When replacing the split pin, do not slacken the nut to align the hole, always tighten. Failure to regularly check this nut will result in serious wear to hub, which is expensive to repair.
- It is most important that all gearbox bolts are regularly checked to be very tight. When the machine is new there will be a 'bedding in' period where very frequent checking is important.

### Blades

**Caution! When carrying out maintenance work on or near the blades be careful of free-swinging blades over-centering and falling. It is recommended that protective clothing including hardhat and goggles are worn.**

The blades can be re-sharpened by grinding the cutting edges, care must be taken that the blades are of the same weight and length after grinding. Do not overheat when grinding, as this will affect the hardness of the blades. All the blades are free swinging and swivel on hardened steel bushes, which are replaceable. When replacing blades, it is important that blades are replaced in sets, in order to retain balance of the rotor. Bushes must be replaced when new blades are to be fitted.

If the blades are showing any signs of severe wear, damage or cracking, they must be replaced immediately. Never attempt to weld the blades, as this will make them very brittle thus extremely dangerous. Do not take risks with the cutting blades - if in doubt, replace.

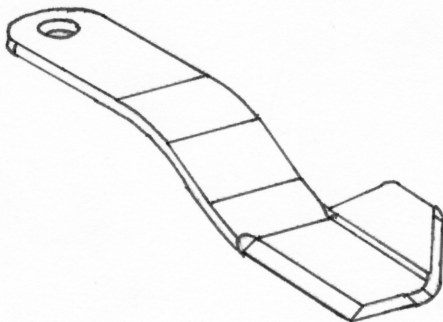

LH Blade

# Spearhead Multi-Cut 420

## 420 Slip Clutch Maintenance & Settings

Check the condition of the friction discs before use and following periods of storage. Release the tension from the springs and turn the clutch body while holding the inner P.T.O hub stationary, if unable to turn freely strip down clutch and free off seized parts ensuring to remove all traces of rust. Rebuild and adjust the spring compression to the original setting.

Following seasonal use, unload the spring tension and store clutch assembly in a dry place. Check condition of friction linings and reset spring compression to original height before use.

Should the assembly overheat due to frequent or prolonged clutch slipping, dismantle for inspection. The original thickness of the lining is 3.0 mm, replace them when worn to 2.0 mm. Clean up all contact surfaces and replace any damaged components before assembly.



### Warning

The slip clutch is there to protect the gearbox. If the blades strike a large obstacle they may get damaged or break - avoid these conditions.

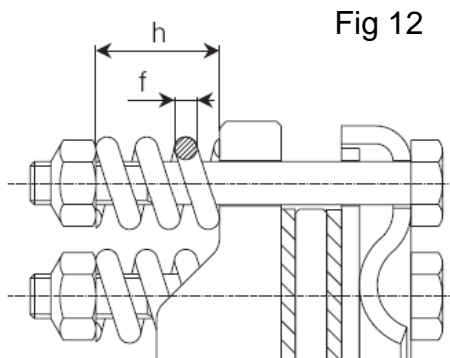

Fig 12 (h)	Fig 12 (f)	Position	Setting	Machine	Part no
33.2 mm	7mm	Centre	1000Nm	420	5770409
33.2 mm	7mm	Wing	1000Nm	420	5770410

# Spearhead Multi-Cut 420

---

## Servicing & Maintenance

### Skids

When operating on abrasive soils, particularly in stubbles and similar conditions with thin ground cover, excessive skid wear may be expected. To provide extra protection and to prolong life of the skids, special hard facing rods are available.

### Wheels



#### Warning

Heavy-duty industrial tyres have been fitted to *420 Rotary Cutter* for convenience of tyre removal, the wheel rims are of the split rim type.

When removing the wheels only remove the five larger hub nuts.

**Never** undo the smaller outer nuts (which are painted red for danger) when removing the wheel.

The outer nuts must not be loosened until the valve has been removed and the inner tube is entirely deflated. **Then, and only then may the outer bolts can be loosened. Failure to observe these precautions could seriously injure and could even result in loss of life.**

If in any doubt consult a tyre repair specialist or Spearhead's Service Department.

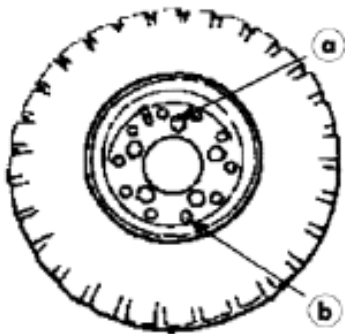

- A Hub Nuts
- B Outer Nuts (painted red)

# Spearhead Multi-Cut 420

---

## Storage

Before storing away, thoroughly wash the machine removing all traces of grass and dirt. Great care must be taken when washing with high-pressure hoses, do not hold the water jet close to the paintwork. Use steam cleaners with caution and be sure to remove all detergents to avoid any discoloration or damage to the paintwork.

Grease all grease points until fresh grease shows. Liberally apply used engine oil along the whole length of the hinges of each wing section. The centre clutch coupling and wing shafts must be removed and stored under cover. Smear grease on the hydraulic ram chromed rods for protection

## After Storage

Disassemble clutches and with an emery cloth remove all traces of rust on the metal clutch plates. Check condition of the friction plates, if there is any sign of over heating, wear or cracking, replace with new. Do not attempt to use the machine with damaged slip clutch plates.

Reassemble the clutch units and tighten the bolts to achieve the correct spring length. Do not over tighten or the clutches will not work.

Check condition of tyres and pressure then follow the maintenance procedure covered in the servicing part of this manual. Pay particular attention to the condition of guards and blades.

Remember the *420 Rotary Cutter* is designed to withstand the most rigorous conditions and, with a little care and attention, will give many years of trouble free service. So as not to invalidate the warranty and to avoid problems, use only genuine parts and make sure the machine is not driven at a speed in excess of 1000r.p.m. on the PTO.

# Spearhead Multi-Cut 420

## Trouble Shooting Guide

### Broken or Damaged Blades

1. Raise cutting height to avoid striking the ground
2. Remove or avoid obstacles such as rocks
3. Check rotor speed
4. Ensure a steady feed into drive (Do not snatch the PTO)

### Damaged Blade Holder

1. As above
2. Failure to keep tight centre retaining nut

### Damage Gearboxes

1. Seized slip clutch.
2. Telescopic shafts bottoming out
3. Engaging drive with too much power / revs
4. Lack of grease on sliding tubes of drive shaft

### Damage To PTO Shaft

1. Seized slip clutch
2. Telescopic tube bottoming out
3. Engaging drive with too much power / revs
4. Turning too sharp
5. Not enough overlap
6. Lack of grease
7. Build up of Debris under drive shaft

### Gearbox Overheating

1. Incorrect oil/grease level
2. Incorrect grade of oil/grease
3. Incorrect operating speed
4. Machine overloaded
5. Rubbish around the gearbox reducing air circulation

### Slip Clutches Overheating

1. Machine overloaded
2. Incorrect operating speed
3. Incorrect setting
4. Blades hitting the ground

### Oil Leak From Gearbox

1. Damaged shaft seal check for foreign matter (wire-string)
2. Faulty breather
3. Damaged gasket
4. Incorrect oil/grease level

### Metal Fatigue On Frame

1. Too fast a traveling / operating speed for conditions
2. Wings not floating i.e. following the ground contours (check tractor spool)
3. Used in a manner or condition contra to its intended purpose

### Excessive Skid Wear

1. Fit optional wheel kit to wings and set skids above the ground.

# Spearhead Multi-Cut 420

---

## The Spearhead Warranty

Spearhead warrants that the Spearhead machine referred to in the Warranty Registration Form will be free from defects in materials and workmanship for a period of 12 months from the date of sale. This warranty does not affect your statutory rights, but merely adds to them. Should you have a problem within 12 months from the date of sale please contact your original Spearhead dealer, or Spearhead's Service Department. Any part found to be defective during this period will be replaced or repaired, at Spearhead's discretion, by the dealer or a Spearhead Service Engineer.

### Spearhead Warranty Conditions

1. The Warranty Registration Form must be completed and returned to Spearhead within 30 days of the date of sale
2. This warranty does not cover defects arising from fair wear and tear, wilful damage, negligence, misuse, abnormal working conditions, use in competition, failure to follow Spearhead's instructions (oral or written, including all instructions and recommendation made in the Operator's Manual) or alteration or repair of the machinery without Spearhead's approval.
3. The machinery must have been serviced in accordance with the Operator's Manual and the Service Log must have been kept up to date and made available to the dealer should service, repair or warranty work be undertaken.
4. This warranty does not cover claims in respect of wearing parts such as blades, flails, paintwork, tyres, belts, hydraulic hoses, bearings, bushes, linkage pins, top links, ball ends unless there is a manufacturing or material defect or the cost of normal servicing items such as oils and lubricants.
5. This warranty does not cover any expenses or losses incurred whilst the machinery is out of use for warranty repairs or parts replacement.
6. This warranty does not extend to parts, materials or equipment not manufactured by Spearhead, for which the Buyer shall only be entitled to the benefit of any such warranty or guarantee given by the manufacturer to Spearhead. Only genuine Spearhead replacement parts will be allowable for warranty claims.
7. All parts replaced by Spearhead under warranty become the property of Spearhead and must be returned to Spearhead if Spearhead so request. Such parts may only be disposed of after a warranty claim has been accepted and processed by Spearhead.
8. Spearhead is not liable under this warranty for any repairs carried out without Spearhead's written consent or without Spearhead being afforded a reasonable opportunity to inspect the machinery the subject of the warranty claim. Spearhead's written consent must, therefore, be obtained before any repairs are carried out or parts replaced. Use of non- Spearhead parts automatically invalidates the Spearhead Warranty. Failed components must not be dismantled except as specifically authorised by Spearhead and dismantling of any components without authorisation from Spearhead will invalidate this warranty.
9. All warranty claims must be submitted to Spearhead on Spearhead Warranty Claim Forms within 30 days of completion of warranty work.

**Using the machine implies the knowledge and acceptance of these instructions and the limitations contained in this Manual.**

# Spearhead Multi-Cut 420

---

## Spearhead Warranty

### Extended Warranty

As an extension to the 12-month warranty set out above, Spearhead will provide an additional 12-month warranty cover subject to the Spearhead Warranty Conditions above and the Extended Warranty Conditions below.

### Extended Warranty Conditions

1. The extended warranty applies to hydraulic pumps, motors, valves and gearboxes only. It does not apply to other parts, to consumables such as lubricants, seals or filters or to labour charges.
2. The machinery must have had an annual service carried out by an Authorized Spearhead Dealer or a Spearhead Service Engineer within 1 month of the first anniversary of the date of sale and the Service Report form must have been completed and stamped by the servicing dealer or Spearhead Service Engineer and sent to Spearhead within 14 days after the first annual service.
3. The extended warranty does not cover costs of transportation of the machinery to or from the dealer or Spearhead or the call out costs or traveling expenses of on-site visits

### Transfer of Warranty

The Spearhead warranty may be transferred to a subsequent owner of the machinery (for use within the UK) for the balance of the warranty period subject to all of the warranty conditions and provided that the Change of Owner form is completed and sent to Spearhead within 14 days of change of ownership.

**Spearhead reserves the right to make alterations and improvements to any machinery without notification and without obligation to do so.**

Spearhead Machinery  
Green View,  
Salford Priors,  
Evesham,  
Worcestershire,  
WR11 8SW

Tel: 01789 491860

Fax: 01789 778683

[www.spearheadmachinery.com](http://www.spearheadmachinery.com)

[enquiries@spearheadmachinery.com](mailto:enquiries@spearheadmachinery.com)