

# SPEARHEAD

## MULTICUT 300

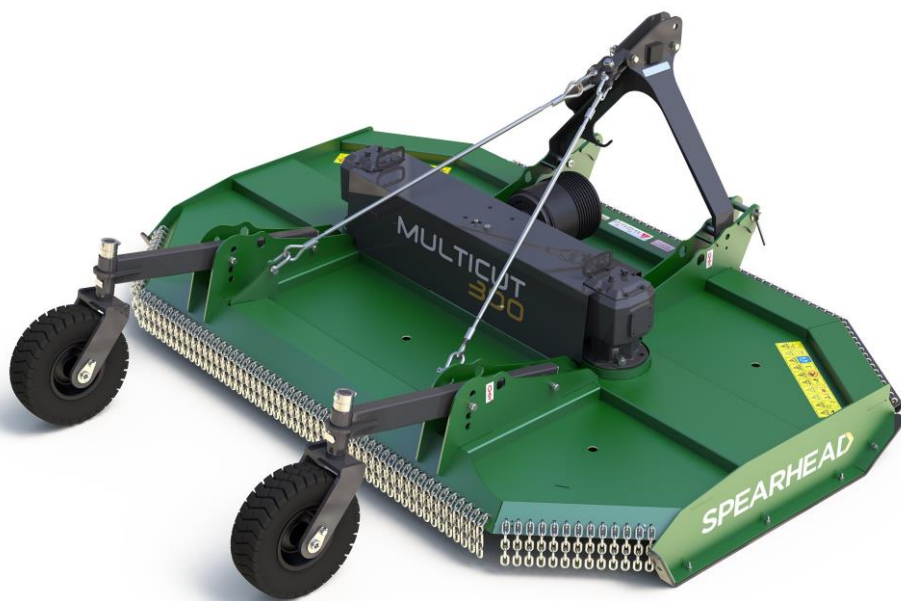

**Edition 9.1 – December 2020**

**Part No – 8999009**

# HANDBOOK

## IMPORTANT

### VERIFICATION OF WARRANTY REGISTRATION



#### DEALER WARRANTY INFORMATION & REGISTRATION VERIFICATION

It is imperative that the selling dealer registers this machine with Spearhead Machinery Limited before delivery to the end user – failure to do so may affect the validity of the machine warranty.

To register machines go to the Spearhead Machinery Limited web site at [www.spearheadmachinery.com](http://www.spearheadmachinery.com), log onto 'Dealer Inside' and select the 'Machine Registration button' which can be found in the Service Section of the site. Confirm to the customer that the machine has been registered in the section below.

Should you experience any problems registering a machine in this manner please contact the Spearhead Service Department on 01789 491867.

#### Registration Verification

<b>Dealer Name:</b>	.....
<b>Dealer Address:</b>	.....
<b>Customer Name:</b>	.....
<b>Date of Warranty Registration:</b>	...../...../.....
<b>Dealer Signature:</b>	.....

#### NOTE TO CUSTOMER / OWNER

*Please ensure that the above section has been completed and signed by the selling dealer to verify that your machine has been registered with Spearhead Machinery Limited.*

**IMPORTANT:** During the initial 'bedding in' period of a new machine it is the customer's responsibility to regularly inspect all nuts, bolts and hose connections for tightness and re-tighten if required. New hydraulic connections occasionally weep small amounts of oil as the seals and joints settle in – where this occurs it can be cured by re-tightening the connection – refer to torque settings chart below. The tasks stated above should be performed on an hourly basis during the first day of work and at least daily thereafter as part of the machines general maintenance procedure.

#### CAUTION: DO NOT OVER TORQUE HYDRAULIC FITTINGS AND HOSES

##### TORQUE SETTINGS FOR HYDRAULIC FITTINGS

HYDRAULIC HOSE ENDS		
BSP	Setting	Metric
1/4"	18 Nm	19 mm
3/8"	31 Nm	22 mm
1/2"	49 Nm	27 mm
5/8"	60 Nm	30 mm
3/4"	80 Nm	32 mm
1"	125 Nm	41 mm
1.1/4"	190 Nm	50 mm
1.1/2"	250 Nm	55 mm
2"	420 Nm	70 mm

PORT ADAPTORS WITH BONDED SEALS		
BSP	Setting	Metric
1/4"	34 Nm	19 mm
3/8"	47 Nm	22 mm
1/2"	102 Nm	27 mm
5/8"	122 Nm	30 mm
3/4"	149 Nm	32 mm
1"	203 Nm	41 mm
1.1/4"	305 Nm	50 mm
1.1/2"	305 Nm	55 mm
2"	400 Nm	70 mm

# MULTICUT 300

---

# MULTICUT 300

---

## Contents

Important Safety	6
Safety Stickers	7
Introduction	8
Safety First	8
Tractor Requirements	8
Attaching To The Tractor	9
Setting Up & Adjustments – Height	10
Machine Protection	10
Operation	10
Transportation	11

## Servicing & Maintenance

Safety First	12
Torque Settings	12
Daily Every 8 Hours	13
Every 16 Hours	13
Regularly	13
Blades	14
Skids	15
Storage	15
After Storage	15
Trouble Shooting Guide	16

# MULTICUT 300

---

# MULTICUT 300

---

## Important



## Safety

- Never operate the machine with other people present, as it is possible for debris, including stones, to be discharged from the front and rear of the flail hood.
- Always ensure all cab safety guards are in place and all tractor windows closed.
- Never allow an inexperienced person to operate the machine without supervision.
- Never allow children to play on or around the machine at any time.
- Never attempt any maintenance or adjustment without first disengaging the PTO, lowering to the ground, stopping the tractor engine and applying the tractor parking brake.
- Before leaving the tractor cab always ensure that the machine is firmly on the ground, and the rotor has stopped spinning
- Never stop the engine with the PTO engaged.
- Always check that all guards are properly fitted, check there are no damage or loose parts. Particular attention should be given to the flails to ensure they are not damaged, cracked or missing.
- Never operate with flails missing.
- Always operate PTO at recommended speed 540/1000 R.P.M as indicated on the sticker.
- Always inspect work area for wire, steel posts, large stones and other dangerous materials and remove before starting work.
- Never operate with wire around rotor. Stop immediately.
- Never attempt to use the machine for any purpose other than that it was designed for.
- Ensure that all warning labels are always visible and that they are not damaged, defaced or missing.
- Never transport with the PTO engaged.
- When parking up always lower to the ground

# MULTICUT 300

## Safety



**Warning**  
Stay clear of mower blade as long as engine is running.



**Warning**  
Danger – flying objects keep safe distance from the machine as long as the engine is running.



**Warning**  
Shut off engine and remove key before performing maintenance or repair work.



**Warning**  
*Check all nuts are tight every 8 hours.*



**Warning**  
Carefully read operator's manual before handling this machine. Observe instructions and safety rules when operating.

# MULTICUT 300

---

## Introduction

The Spearhead Multi-Cut 300 is a very robust high capacity Rotary Cutter that is easy to operate and maintain, but to ensure trouble-free operation this manual should be carefully studied.

## Safety First

Do not start the machine until you fully understand operation and safety precaution requirements. Always ensure the operators are proficient with the operation of this type of this machine.

## Tractor Requirements

- Spearhead strongly recommends 75hp-plus tractor with **CATEGORY 2** rear linkage.
- Ensure there is sufficient weight on front wheels of the tractor for safe transport and stability.
- PTO must be independent live drive to enable continuous PTO drive even when tractor clutch is pressed down.
- Before hitching, ensure position control is selected. Do not attempt to hitch in draft control.
- Check chains and stabilizers must be in good working order to hold the machine firmly. Do not operate without checking that chains and stabilizers are tight.
- Spearhead particularly recommend 'turn buckle' type check chains
- Set linkage lift rods to an equal length.



# MULTICUT 300

## Attaching To The Tractor

Fit the machine to the tractor linkage in the standard way, ensuring the correct match of linkage (**CAT 2 pins**). Check that the top link is in good order and threads are well lubricated. Use stabilisers to take any free movement out of lower link arms.

Before fitting the machine to the tractor linkage you should ensure there is sufficient front weight to ensure the front wheels are always in contact with the ground. This is most important for safe transport and stability when turning on slopes.

Before fitting the PTO for the first time, it may be necessary to adjust the length. There should be maximum engagement of the sliding tubes without bottoming at the shortest operation position. To check, first connect the mower to the tractor. Pull the PTO shaft apart and connect to the tractor PTO output shaft and the gearbox input shaft. Hold the half shafts next to each other in the shortest working position.

If necessary, shorten the inner and outer guard tubes equally (Fig. 2). Shorten the inner and outer sliding profiles by the same length as the guard tubes. File all sharp edges and remove burrs. Grease sliding profiles.

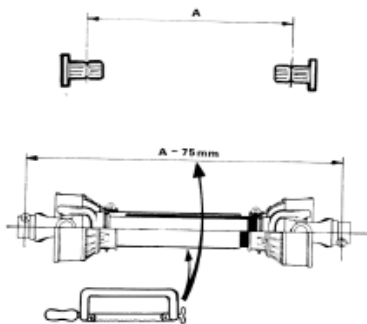

Fig 2

To fit the PTO to the machine, first remove bolt or tapered pin from the slip clutch yoke and push onto splined shaft of gearbox ensuring it is fully engaged before refitting retaining bolt/pin.

To fit the PTO, first clean and grease press pins on the yoke and simultaneously push the PTO drive shaft onto PTO shaft of the tractor until pins engage.

The PTO shaft is fitted with a non-rotating safety guard. It should be secured to the machine and tractor with the two retaining chains provided.

# MULTICUT 300

---

## Setting Up & Adjustment

### Height

Cutting height adjustment is achieved by raising or lowering the wheels. Lowering the wheels produces a longer cut, raising the wheels leaves a shorter cut. Always set machine level front to rear and side to side.

The weight of the machine should be equally distributed between the tractor and the wheels. When set properly this should prevent scalping.

### Machine Protection

To prevent gearbox damage the PTO is fitted with either a shear bolt or knocking clutch. When cutting in extreme conditions where solid objects are likely to be found it is recommended the operator reduces the engine revs to allow the blades to pivot more easily when striking solid objects, and proceed with caution.

The shear bolt or clutch settings should not be altered without reference to the Spearhead Service Department. Never operate without protection, this could result in severe damage to the gearbox and drive lines, as well as infringing the warranty.

### Optional

Anti scalp dish may be fitted to the lower blade carriers to ease the machine over obstacles and prevent damage to the blades.

### Operation

Engage the PTO only when the tractor engine is at low revs to prevent shock damage to the machine, slowly increase the engine revs to achieve the standard 1000 PTO speed. (As indicated on the sticker).

If at any time serious vibration occurs, stop the engine immediately and check that no blades are missing - following all safety precautions. The cause must be found and rectified immediately or other components may be affected.

# MULTICUT 300

## Operation

When in work, lower the machine to the ground carrying its weight on the wheels, allowing the machine to follow the contours of the ground and ensuring there is sufficient slack in the wire rope. Select a sensible forward speed bearing in mind the density of growth, the terrain, and the available horsepower, taking extra care when turning, particularly on slopes. When turning, it is not necessary to lift the machine off the ground but instead allow sufficient room to turn in a large radius. The machine only needs to be raised when turning in a tight corner or reversing over dense undergrowth or when operating on the front linkage. The machine is fitted with, as standard, 4 high lift blades complete with fin, to aid spreading/mulching.

Quality of finish is determined by the forward speed i.e. a slow speed will produce a high quality of cut, whereas faster forward speeds are used when high output is first priority.

When operating, particularly in confined areas, it is possible to cut going backwards but it is advisable to slightly raise the machine, particularly if in dense growth where there is a risk of hitting hidden solid obstacles obscured by dense undergrowth.

Always exercise particular care when operating over uneven ground surfaces. Do not allow the blades and blade holders to frequently hit the ground.

## Direction of blades for machine with skirts

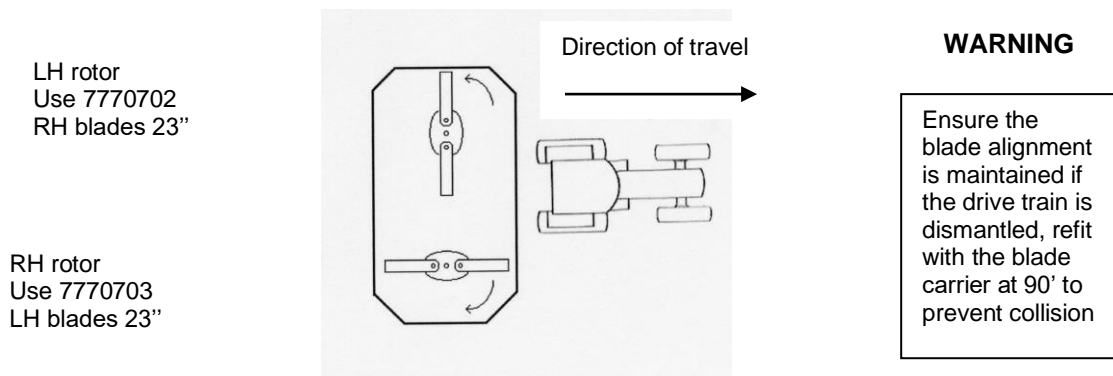

## Transportation

Please observe Public Highway Regulations concerning the towing of implements, and securely attach a registration and lighting board. Take care to slow when travelling over rough ground and avoid bouncing machine on linkage causing unnecessary strain.

Maximum speed with a mounted implement is 20mph (30 km/h)

# MULTICUT 300

## Service & Maintenance

### Safety First

- Never leave the tractor seat without first disengaging the PTO and stopping the engine.
- Ensure all rotating parts have stopped turning.
- Never attempt any repairs, maintenance, service or any other checks with the machine carried on the tractor hydraulics.
- Always fully lower to the ground, or securely prop the machine on substantial servicing stands.
- Always replace all guards and retaining chains after servicing/maintenance is completed.



#### Important

On delivery of your machine check that the dealer has completed the P.D.I. form ensure the warranty registration form is completed and returned.

It is imperative that the following checks are carried out in order not to invalidate your warranty; these are carried out **before the first operation, after the first hour, then after 4 hours**. These checks are:

- Wheel nuts and tyre pressure (50psi)
- Gearbox bolts
- Blade bolts are fully tightened and in particular the castle headed nut on the blade rotor
- Retaining bolts on the drive shaft
- Grease all points
- After the first 50 hours drain and replace the gearbox oil. Replace with EP90 Gear oil
- It is your responsibility to maintain, to ensure a long reliable working life

### Torque Settings

The Torque figures given below are recommended maximum settings only.

Size:	Tensile strength:	Description:	Torque setting: Nm
M16	8.8	Gearbox bolts	280
M16	8.8	Blade carriers	280
M24	8.8	Blade bolts	950

# MULTICUT 300

---

## Daily / Every 8 hours

- Grease all grease points, on PTO, including secondary drive line under the center guard
- Check condition of blades and blade bushes and ensure all retaining bolts are fully tight.
- Check gearbox oil, replenish with 'EP90' gear oil as necessary to the correct level line on the dipstick provided with each gearbox.
- Dismantle and clean PTO sliding surfaces and re-grease. Grease universal joints (Fig. 3).

**Fig. 3**

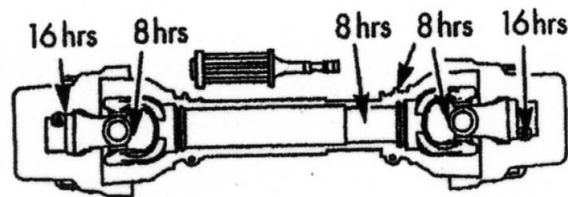

## Every 16 hours

- Grease PTO inner tube and push pins (Fig. 3)

## Regularly

- Check there is no wrapping of string, plastic, grass or other debris between rotor boss and blades.
- Inspect gearbox seals for leaks.
- Regularly check the rotor boss retaining castle nut for tightness (part no.5771409). First remove the split pin, select the correct size (46mm) socket in 3/4" drive and fully tighten the nut. When replacing the split pin, do not slacken the nut to align the hole, always tighten. Failure to regularly check this nut will result in serious wear to hub, which is expensive to repair.
- It is most important that all gearbox and blade bolts are regularly checked to be very tight. **When the machine is new there will be a 'bedding in' period where very frequent checking is important.**

# MULTICUT 300

---

## Blades

**Caution!** When carrying out maintenance work on or near the blades be careful of free-swinging blades over-centring and falling. It is recommended that protective headgear, gloves and goggles are worn.

The blades can be re-sharpened by grinding the cutting edges and care must be taken that the blades are of the same weight and length after grinding. Do not over heat when grinding, as this will affect the hardness of the blades.

All the blades are free swinging and swivel on hardened steel bushes, which are easily replaced. When replacing blades, it is important that blades are replaced in sets, in order to retain balance of the rotor. Bushes must be replaced when new blades are to be fitted.

If the blades are showing any signs of severe wear, damage or cracking, they must be replaced immediately. Never attempt to weld the blades; this will make them very brittle thus extremely dangerous.

Do not take risks with the cutting blades - if in doubt, replace.



### Warning

The slip clutch is there to protect the drive train. If the blades strike a large obstacle they may get damaged or break so avoid these conditions.

The two rotor blade carriers are timed to ensure the blades do not clash, ensure timing is correct after carrying out any maintenance to the drive line.

The upper blade carriers must be positioned at 90° to each other, if the driveline is dismantled for any maintenance they must be checked to ensure the swinging blades do not collide.

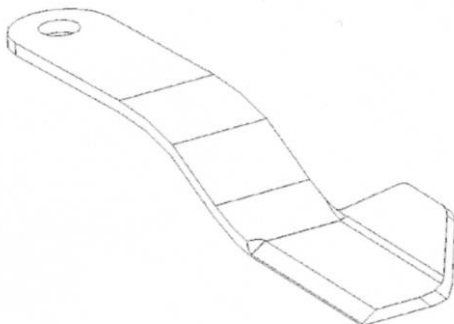

LH Blade 7770703

# MULTICUT 300

---

## Skids

When operating on abrasive soils, particularly in stubbles and similar conditions with thin ground cover, excessive skid wear may be expected. To provide extra protection and to prolong life of the skids, special hard facing rods are available.

If working in wet and muddy conditions, ensure that debris is not allowed to build up on the deck.

## Storage

Before storing away, thoroughly wash the machine removing all traces of grass and dirt. Great care must be taken when washing with high-pressure hoses, do not hold the water jet close to the paintwork. Use steam cleaners with caution, be sure to remove all detergents to avoid any discolouring or damage to paint.

Grease all grease points until fresh grease shows. Store PTO shaft in a dry place.

## After Storage

Check condition of the tyre (where applicable) and then follow the maintenance procedure covered in the servicing part of this manual. Pay particular attention to the condition of guards and blades.

Remember the 3000 Swipe is designed to withstand the most rigorous conditions and, with a little care and attention, will give many years of trouble free service.

So as not to invalidate the warranty and to avoid problems, use only genuine parts and make sure the machine is not driven at a speed in excess of 540/1000 rpm on the PTO. As indicated on the speed sticker.

## Trouble Shooting Guide

### Broken or damaged blades

- Raise cutting height
- Avoid obstacles
- Timing incorrect
- Ensure a steady feed into drive (do not snatch the PTO)
- Fit anti scalp dish

### Damage blade holders

- Raise cutting height
- Avoid obstacles
- Failure to keep centre retaining nut tight
- Fit anti scalp dish

### Gearbox overheating

- Incorrect oil level
- Incorrect grade of oil
- Incorrect operating speed
- Machine overloaded
- Rubbish around the gearbox reducing air circulation

### Shear bolt failure

- Machine overloaded
- PTO engaged with too much power/revs
- Blades hitting the ground

### Damage to rubber bonded Yoke

- Shock loading from either poor start-up or blades hitting something

### Damage to PTO shaft & gearboxes

- Inoperative torque limiter
- Seized slip clutch
- Telescopic tube bottoming out
- Engaging drive with too much power/revs
- Lifting machine too high
- Not enough overlap
- Lack of grease on sliding tubes of drive shaft
- Shock loading as a result of impact damage due to the blade carrier striking an obstacle.

### Metal fatigue on frame

- Too fast a travelling or operating speed for the conditions
- Machine not floating, i.e. not following the ground controls (check position of top link).



Spearhead Machinery  
Station Road,  
Salford Priors,  
Evesham,  
Worcestershire,  
WR11 8SW

Tel: 01789 491860

Fax: 01789 778683

[www.spearheadmachinery.com](http://www.spearheadmachinery.com)  
[enquiries@spearheadmachinery.com](mailto:enquiries@spearheadmachinery.com)