

Spearhead

**EXCEL Reach Mower
565/605/645T
6000/6000LR/6000T**



**Edition 5.0 – March 2009
Part No. 8999003**

HANDBOOK

Spearhead 5 Series

CE Declaration of Conformity, Conforming to EU Machinery Directive 2006/42/EC

We, Spearhead Machinery Ltd, Green View, Salford Priors, Evesham,
Worcestershire, WR11 8SW hereby declare that:

Product.....
Product Code.....
Serial No.....
Type.....

Manufactured by: Alamo Manufacturing Services (UK) Limited, Station Road,
Salford Priors, Evesham, Worcestershire, WR11 8SW

Complies with the required provisions of the Machinery Directive 2006/42/EC.
The Machinery Directive is supported by the following harmonized standards:

- BS EN ISO 14121-1 (2007) Safety of Machinery – Risk Assessment, Part 1: Principles Part 2: Practical Guide and Examples of Methods.
- BS EN ISO 12100-1 (2010) Safety of Machinery – Part 1: Basic Terminology and Methodology Part 2: Technical Principles.
- BS EN 349 (1993) + AI (2008) Safety of Machinery – Minimum Distances to avoid the Entrapment of Human Body Parts.
- BS EN 953 (1998) Safety of Machinery – Guards General Requirements for the Design and Construction of Fixed and Movable Guards.
- BS EN 982 (1996) + AI (2008) Safety Requirements for Fluid Power Systems and their Components. Hydraulics.

The EC Declaration only applies if the machine stated above is used in
accordance with the operating instructions.

Signed



(On behalf of Spearhead Machinery Ltd)

Status

General Manager

Date

01/03/2009

Spearhead 5 Series

Contents

General Information

Introduction.....	4
Specification.....	5
Machine Safety Stickers.....	6
Safety Recommendation.....	7
Front Mounted Machines.....	9
Lighting Kits.....	9
Warning Signs.....	9
Training.....	9

Installing/Removing Machine

Tractor Requirements.....	10
Lifting Points.....	10
Attaching your Machine to the Tractor - Using Axle Mounting.....	11
Attaching your Machine to the Tractor – using 3 point linkage.....	13
Running up your Machine.....	18
Removing from the Tractor.....	19

Set-up

Hydraulic Controls.....	20
How your controls work.....	21
Cutting Head Set-up.....	22
Hedge Cutting.....	23
Grass Cutting.....	24

Operation

Optional hydraulic rear roller.....	25
Operation Warnings.....	26
Moving into Transport Position.....	27
Transport to Work Position.....	29
Engaging head drive.....	29
Disengage head drive.....	29
Break back.....	30
Tractor forward speed.....	31
Cutting sequence.....	31
Wire Trap.....	32
High Voltage Cables.....	32
Optional head float.....	33
Optional arm float.....	34
Debris blower.....	35
Oil Cooler.....	35

Spearhead 5 Series

Contents Cont.

Operation

Autopilot.....	36
Quad saw.....	41
Telescopic Arm.....	44
Narrow lane bracket.....	45
Rotor reverse.....	45

Service & Maintenance

Greasing / Lubrication.....	46
Hydraulic hoses.....	48
Oil Supply.....	49
Oil Recommendations.....	49
Filtration Maintenance.....	49
Flail Head.....	50
Cables.....	51
Pin & Bushes, Storage.....	51
Storage.....	51
Torque Settings.....	52
Regular Service Chart.....	52

Diagnostics

Troubled shooting Excel / Highway.....	53
Pump and Motor failure.....	56
Hydraulic Diagram.....	57
Notes.....	61

Warranty

The Spearhead Warranty.....	62
Extended Warranty.....	63

Spearhead 5 Series

Introduction

The EXCEL is a very robust high capacity reach mower that is easy to operate and maintain. To ensure trouble-free operation this manual should be carefully studied.

The term Left and Right hand applies to the machine when coupled to the tractor and viewed from the rear, this also applies to the tractor.

Important Note

The information contained in this manual is correct at the time of publication.

However, in the course of constant development, changes in specification are inevitable. Should you find the information given in this book different to the Machine it relates to please contact the "After Sales Department" for advice.

Please ensure that this manual is handed to the operator before using the machine for the first time. The operator must fully understand the contents of this manual before using this machine.
(If the machine is resold the Manual must be given to the new owner.)

Spearhead 5 Series

Specification

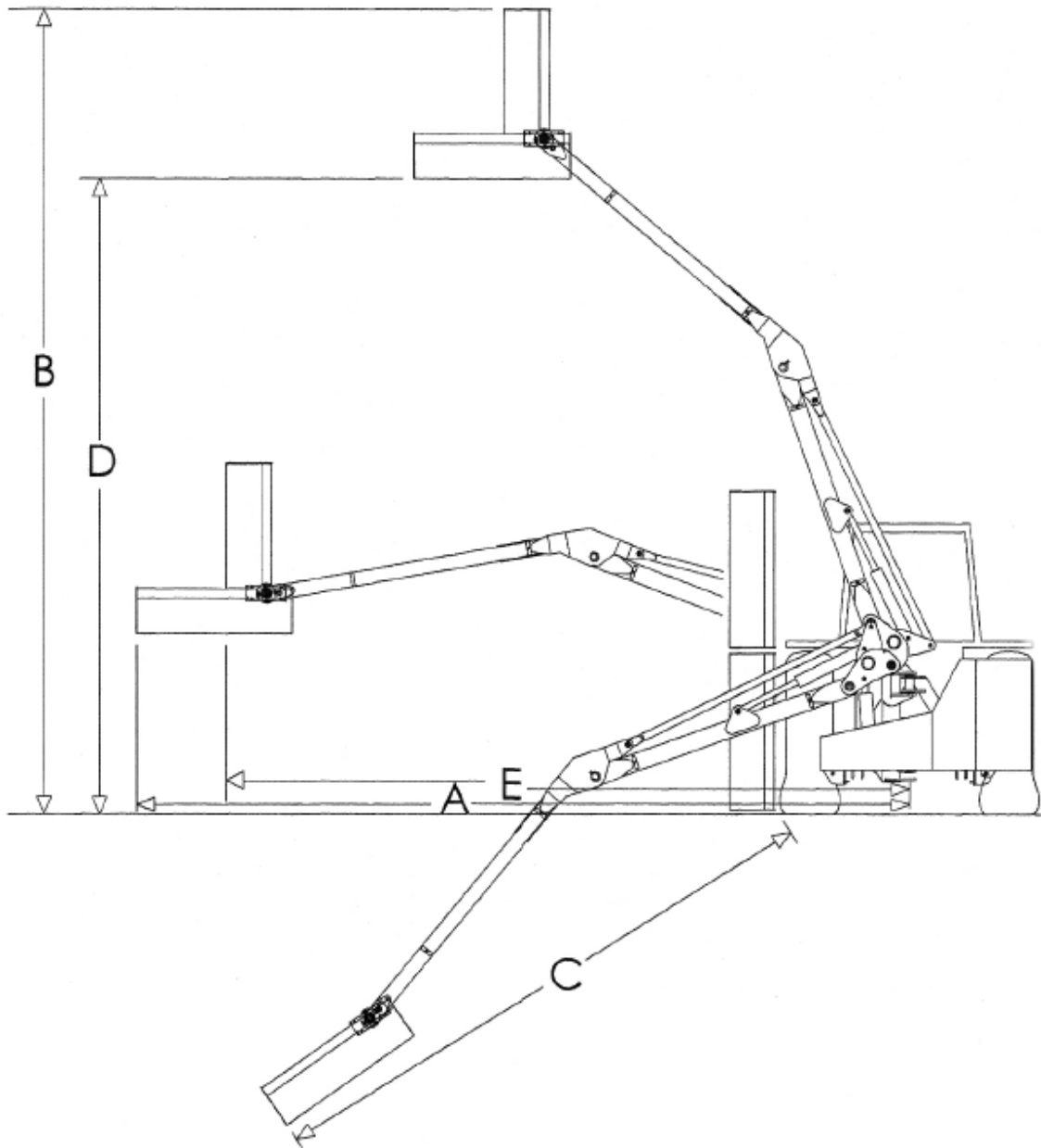

	Excel 504	Excel 565	Excel 605	Excel 645T
Weight including oil (kg)	1340	136	1383	1543
Tractor (hp)	70-95	80-120	90-130	95-140
Minimum tractor weight (kg)	2500	3250	3500	4000
Oil tank capacity	240	240	240	240
A reach (m)	5	5.6	6	6.4
B reach (m)	5.6	6.1	6.3	7
C reach (m)	3.3	4.1	4.5	4.8
D reach (m)	4.4	4.6	4.8	5.4
E reach (m)	4.3	4.9	5.2	5.7

Spearhead 5 Series

Machine Safety Stickers



Warning
Avoid fluid escaping under pressure. Consult technical manual for service procedures.



Warning
Shut off engine and remove key before performing maintenance or repair work.



Warning
Danger – flying objects keep safe distance from the machine as long as the engine is running.

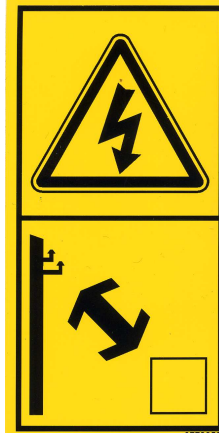

Warning
Beware of overhead electrical power line.



Warning
Stay clear of mower flails.



Warning
Carefully read operator's manual before handling this machine. Observe instructions and safety rules when operating.



Warning
Do not remove / open guard..

Spearhead 5 Series

Safety Recommendations

Beware of the following Potential Dangers associated with the use of this machine:

- Becoming trapped when hitching or unhitching
- Tractor overbalancing when arm is extended
- Electrocution due to hitting overhead power lines
- Getting caught on rotating power take off (PTO)
- Being hit or caught by any moving part, e.g. belts, pulleys, arms, cutting head
- Being hit by flying debris or machine parts due to machine damage
- Machine overbalancing when not in use
- Injection of high pressure oil from damaged couplings or hydraulic hoses
- Accidents due to collision with other machines, or debris left on road

Always

- Ensure the operator has read this handbook and has been trained to use the machine.
- Ensure all cab safety guards are in place and all tractor windows closed.
- Before leaving the tractor cab always ensure that the flail head is firmly on the ground, no weight is on the machine's hydraulics and the rotor has stopped spinning.
- Check that all guards are properly fitted and there are no damaged or loose parts. Particular attention should be given to the flails to ensure they are not damaged, cracked or missing.
- Inspect work area for wire, steel posts, large stones and other dangerous materials and remove before starting work.
- Beware of the danger of overhead power cables. The operator must be aware of the maximum height and reach of the machine when working under power cables. The minimum legal height for 11,000 and 22,000-volt cables is 5.2 metres from the ground. When fully extended, the machine may well exceed this height so extreme caution should be practised. For more information contact the Health and Safety Executive or your local power company.
- Ensure that all warning labels are always visible and that they are not damaged, defaced or missing..
- Lower the head to the ground when parking up
- Fit locking pins to slew and height before transport and before unhitching when applicable.
- Wear ear defenders if operating without a quiet cab or with the cab windows open.
- Ensure tractor guards are fitted correctly and are undamaged
- Work at a safe speed, taking into account terrain, passing vehicles and obstacles
- Ensure that the tractor meets the minimum weight recommendations of the machine manufacturer and that ballast is used if necessary
- Check that machine fittings and couplings are in good condition
- Follow the manufacturer's instructions for attachment and removal of machine from the tractor
- Use clear warning signs to alert others to the type of machine working in the vicinity. Signs should be placed at both ends of the work site and should be in accordance with Department of Transport recommendations.
- Ensure flails are of the type recommended by the manufacturer, are securely fitted and are undamaged.
- Ensure hydraulic pipes are correctly routed to avoid damage from chafing, stretching, pinching or kinking.

Spearhead 5 Series

- Disengage the machine, stop the engine and remove the key before leaving the tractor cab for any reason.
- Clean up any debris left at the work site.
- Ensure that when you remove the machine from the tractor it is secured in a safe position using the stands provided.

Never

- Never operate the machine with other people present, as it is possible for debris, including stones, to be discharged from the front and rear of the flail head.
- Never operate the machine until you have read and understood the relevant Handbook and are familiar with the controls.
- Never use a machine that is poorly maintained or has guards that are damaged or missing
- Never allow an inexperienced person to operate the machine without supervision.
- Never use or fit a machine onto a tractor if it doesn't meet the manufacturer's specification.
- Never use a machine if the hydraulic system shows signs of damage.
- Never attempt to detect a hydraulic leak with your hand, use a piece of card.
- Never allow children to play on or around the machine at any time.
- Never attempt any maintenance or adjustment without first disengaging the PTO, lowering the head to the ground, stopping the tractor engine and applying the tractor parking brake.
- Never leave the cab without removing the ignition key.
- Never operate the tractor or any controls from any position other than from the driving seat.
- Never stop the engine with the PTO engaged.
- Never operate with flails missing.
- Never operate PTO **above** recommended speed, 540 R.P.M.
- Never operate with wire around the rotor. Stop immediately.
- Never use the head at an angle, which may throw debris towards the cab.
- Never attempt to use the machine for any purpose other than that it was designed for.
- Never transport with the PTO engaged
- Never enter the working area of the machine (risk of injury!)
- Never transport with the controls live, always turn off electrical isolator switch (red) and disconnect supply.

Spearhead 5 Series

Front Mounted Machines

When using a front mounted machine, the operator should be aware that the immediate work area is further away from his point of vision than a rear mounted machine. Extra care should be taken when using this type of machine and the intended work area should be thoroughly scrutinised immediately prior to work, to check for potential hidden hazards. Hazards that cannot be removed should be clearly marked to be made visible from the tractor cab.

Cutting heads will throw debris either forwards or backwards and it is vital that suitable safety guards are fitted to protect either the operator, bystanders, or property. Any side guarding fitted to the tractor should be fitted so that it does not impede the operator's view of the work area. Contact your tractor manufacturer or local dealer for further advice.

Lighting Kits

For additional safety, rear mounted lighting kits are available from Spearhead if not already fitted as standard. For more detailed information, contact the Department of Transport or your local Highways Authority

Warning Signs

You are advised to display clear warning signs to indicate the type of machine when working in public places. The signs should be carefully placed at either end of the work site to give advanced warning of the hazard.

Contact your local Highways Authority or Department of Transport for more information.

Roadwork guidelines:

On two-way roads, one set of signs should face the traffic in each direction.

Work should be within 1 mile of the signs.

Work only when visibility is good and at times of low risk, e.g. NOT during rush hour.

Vehicles should show an amber flashing light.

Vehicles should be conspicuously coloured.

Debris should be removed from the road or path at regular intervals and the operator should wear high visibility clothing.

Collect all warning signs promptly when the job is finished.

Training

It is the responsibility of the Spearhead dealer to provide instruction on the safe installation, operation and maintenance of the machine in the first instance. Further training is available from Spearhead Machinery Ltd on request, at cost.

Spearhead 5 Series

Tractor requirements

- Check your tractor size and minimum weight on the Specification table (page 5).
- Before hitching, ensure position control is selected. DO NOT attempt to hitch in draft control.
- Set wheel width as wide as possible.
- Front and offside ballast weight is to be fitted within tractor manufacturer's recommended requirements.
- Check chains and stabilisers must be in good working order to hold the machine firmly. Do not operate without ensuring that chains and stabilisers are tight.
- Spearhead particularly recommend 'turn buckle' type stabiliser.
- Before fitting a front mounted machine to your tractor, seek advice from your manufacturer or dealer to check it's suitability and whether additional linkage, ballast, or weight requirements may be needed.
- A linkage isolation facility is necessary for all models. Set linkage lift rods to an equal length.
- All machines require a 12v fused supply. A 30 amp DIN connector is provided, but if not, the lead should be taken directly to the vehicle battery. Avoid cigarette lighter plugs as they are unsuitable. The supply cable has a red wire for positive (+ve) and black wire for negative (-ve)
- Spearhead particularly recommend "Category 2" three point linkage of ball end type, we do not advise the use of claw type hitching. The quick release latches should be checked, if worn or insecure they may cause accidental damage or personal injury if the machine becomes detached.
- The machine is sold to suit Cat. 2 linkage, some modification may be necessary before mounting on Category 3 linkage.
- Ensure tractor link arms can be isolated from accidental lifting.



Note

For machines fitted with an oil cooler it is important to connect a separate lead direct from the battery to the oil cooler box.

Lifting Points

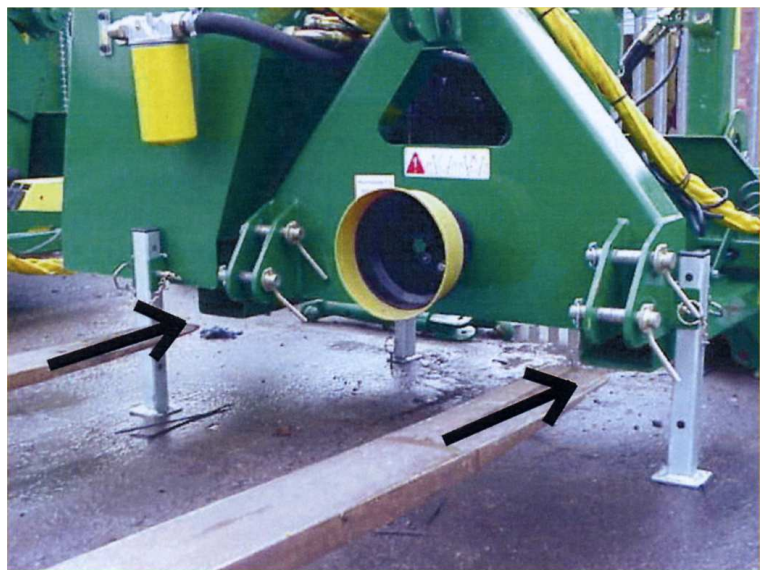

Spearhead 5 Series

Attaching your machine to the tractor – using axle mounting



Warning

It is most important the operator fully understands the procedure for attaching/unattaching the reach mower to/from the tractor. The following text must be fully understood before attempting to attach the machine. If there is any doubt please contact your supplying dealer or Spearhead Service Department. Failure to follow the correct procedure

To attach/unattached the machine could result in personal injury or machine damage. Any resulting damage to a machine is not covered by warranty.

Always be sure to select a level firm surface, such as concrete before attaching to the tractor.

When operating the tractor or machine's controls do so only when seated in the tractor cab. Do not allow anyone to stand on or amongst linkage for any reason.

Follow instructions from Picture 1. if you have axle mounting.

Follow instructions from Picture 9. if you have 3 point linkage mounting

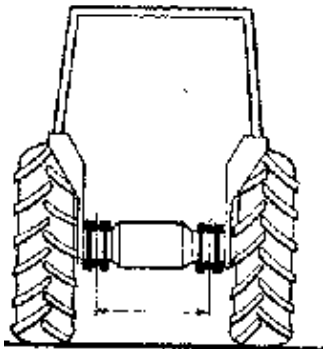

Fitting axle brackets

1. Mount axle brackets as instructed on separate fitting sheet specific to your tractor type.

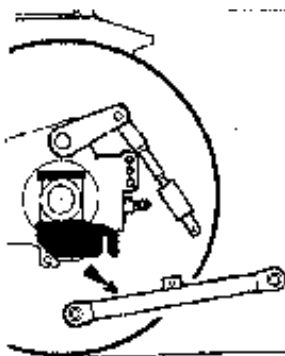

2. Detach tractor draft links.

Spearhead 5 Series

Attaching your machine to the tractor – using axle mounting

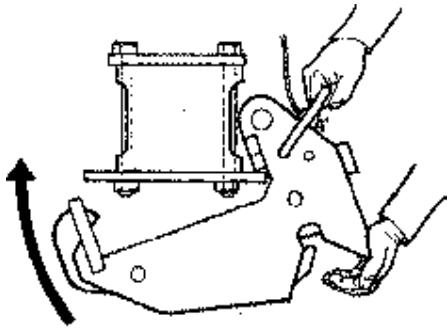

3. Fit lift-in hitch assembly

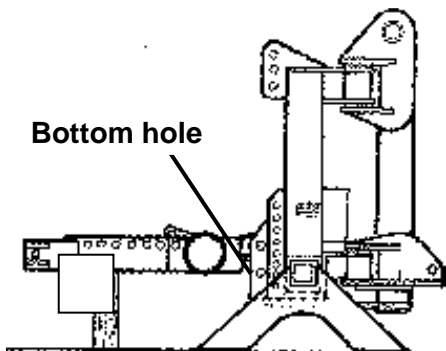

4. Assemble sub frame to suit axle width 1m or 1.1m, mount sub frame assembly to your machine using bottom pin holes.

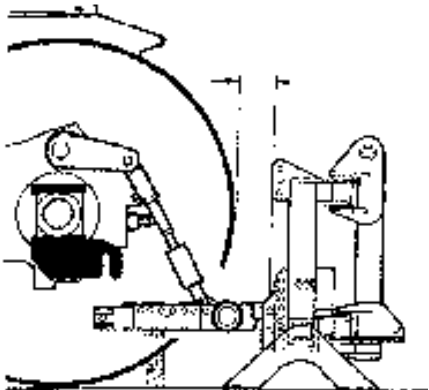

5. Offer up frame to tractor and adjust to give required length. Distance "X" to be kept to the minimum ensuring the machine is close coupled, as a guide set same as original Attach tractor lift links to frame with suitable pins.



Please Note

The hole sizes may not match the tractor links, this will not matter as machine weight is carried on the stabiliser frame when fully mounted.

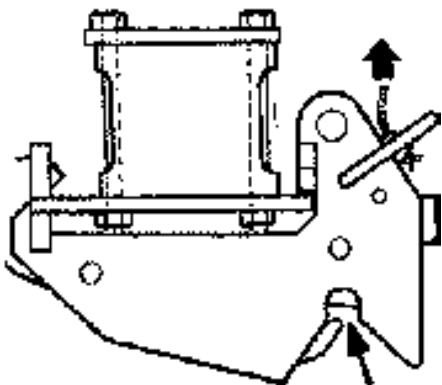

6. Open catch

Spearhead 5 Series

Attaching your machine to the tractor- using axle mounting

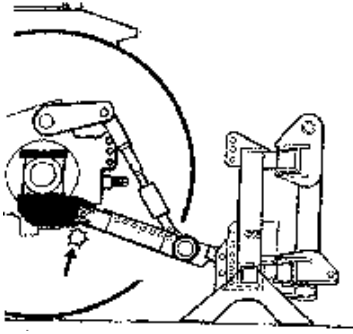

7. Ensure top link is fitted to prevent machine from tipping over before raising Lift frame until it engages in the catches **Note:** You may mount sub frame to the tractor first and follow procedure in step 9.

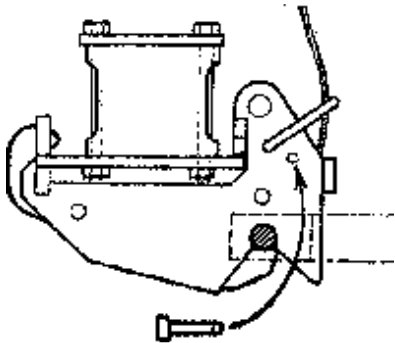

8. Insert catch-locking pin

Attaching your machine to the tractor – when using 3 point linkage

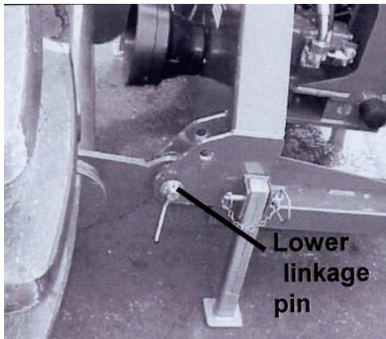

9. Reverse tractor and attach lower link arms by inserting lower linkage pins into the bottom set of holes.

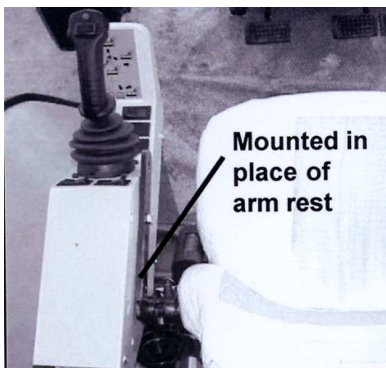

10. Spearhead strongly recommend mounting the control unit to the seat in place of the armrest to the head side of the tractor. Modification and additional bracket may need to be fabricated Consult your local dealer for advice.

An electric 12-volt supply cable will be needed from a 30-amp source.

Spearhead 5 Series

Attaching your machine to the tractor – using 3 point linkage

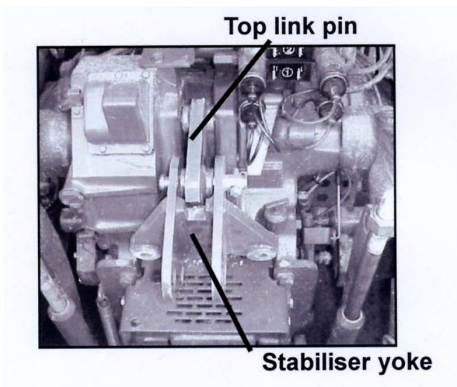

11. Fit stabiliser yoke to the tractor's top hitch bracket.

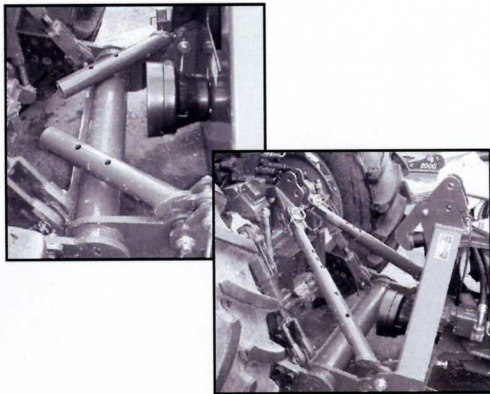

12. Place the stabiliser tubes on to the frame using the pins. Swing forward stabiliser bars and attach to stabiliser yoke. Be sure the stabiliser bars are free to slide. Do not fit locking pins.

Attach top link

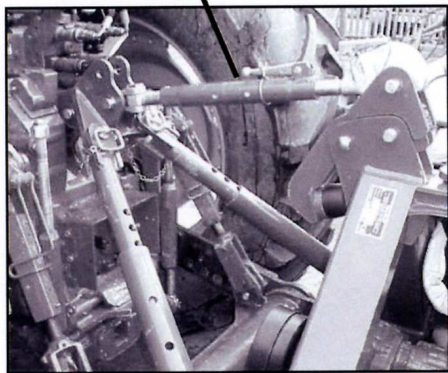

13. Fit top link to machine and the tractor

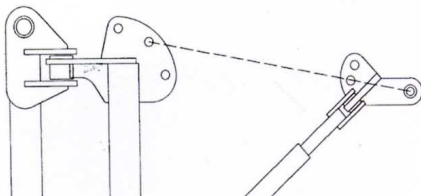

14. Caution: when positioning the top link, it is most important to select the most suitable hole position to achieve as near as possible a straight line between all 3 holes.

Spearhead 5 Series

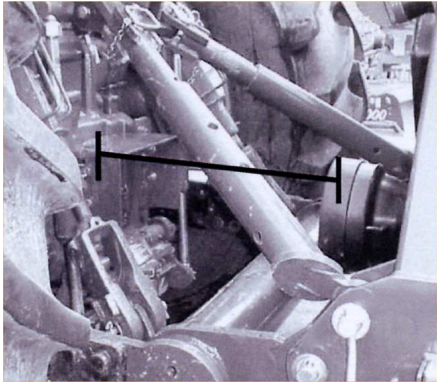

15. Lift the machine up on the tractor's hydraulics until both PTO stub shafts are approximately in line. PTO angle may vary between tractor makes - up to 17° above horizontal is acceptable. Ensure there is enough ground clearance below frame.

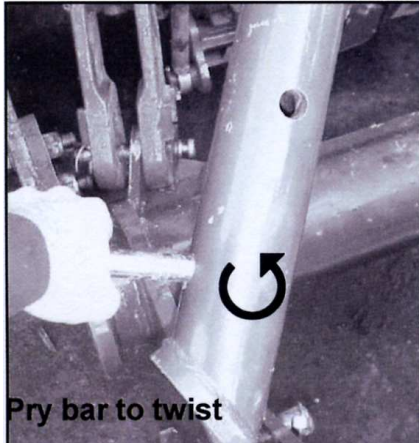

16. Check the machine is at the correct height and level, ensuring both stabiliser bars are at an equal length. Fit locking pins to both stabilisers. Once the stabilising bars are correctly fitted, lower the tractor hydraulics allowing **all the weight of the machine to be carried by the stabiliser bars** (use a pry bar to twist tube if necessary).

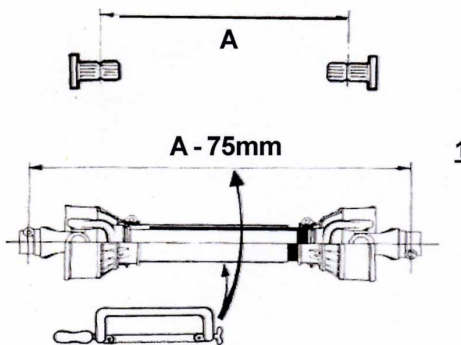

17. If fitting the PTO shaft for the first time measure and cut to the correct length.

Example: A (900mm minus 75mm)
= 825mm

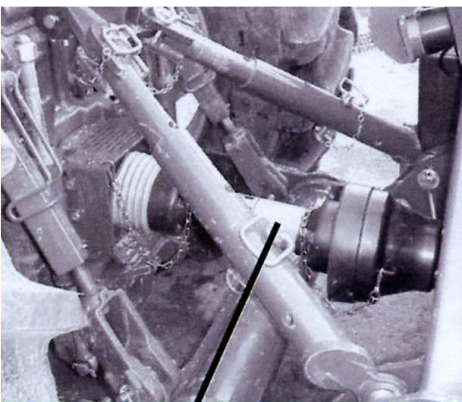

18. Fit the PTO shaft connecting the tractor output shaft to the machine input shaft.



Warning

Always stop the engine and ensure the PTO drive is disengaged before fitting the PTO.

Always replace slew pin for the transport and before unhitching the hedge cutter.

Spearhead 5 Series

Attaching your machine to the tractor – using 3 point linkage

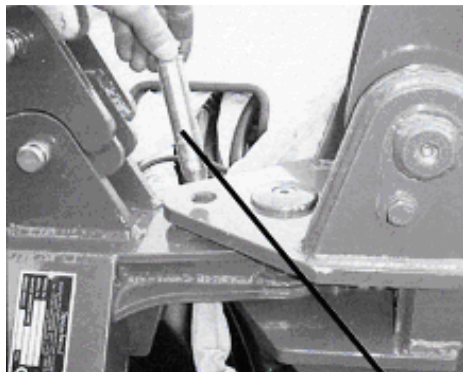

Remove slew-locking pin

19. Remove locking pin from slew post before operating the machine, and slew forward



20. Operate the main arm to bring the frame horizontal by lowering the head weight to the ground.



Adjust top link



21. Adjust top link length until the main frame is vertical.

Spearhead 5 Series

Attaching your machine to the tractor – using 3 point linkage

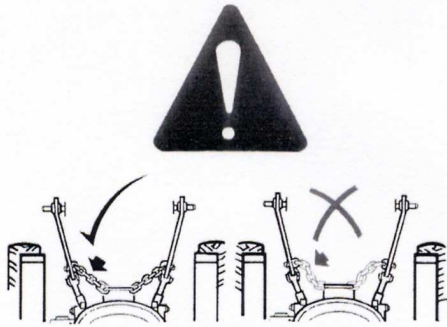

22. Warning - fully tighten chains and linkage stabilisers to hold the machine rigid. There must be no sideways movement, it is very dangerous.



23. Remove parking stands and store safely. The machine cannot be unhitched without these stands.



Warnings

Avoid raising the tractor linkage once the stabiliser bars are locked in place.

Always lower the tractor linkage and allow all the weight to be carried by the stabiliser frame. Failure to observe this warning will result in bending the stabiliser frame.

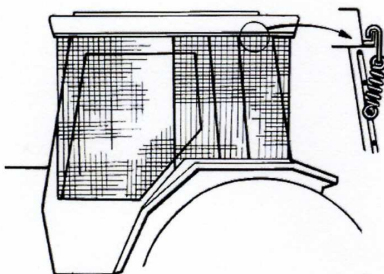

24. Use only tractors with safety glass. If windows are not laminated safety glass, polycarbonate glazing must be fitted between operator and cab meshing. Shape mesh to cover all windows that the driver will look through to view flail head in any operating position. Mesh can be retained by springs and clips supplied, but it is the operators responsibility to ensure guarding is firmly in place.

Spearhead 5 Series

Running up your machine

1. First ensure the rotor is in the 'off' position and PTO drive is disengaged, then start the tractor.
2. Engage PTO into gear and run machine up to half revs, allowing oil to circulate for about 15 minutes before operating arms.
3. Re-check oil level, - check for oil leaks. All Spearhead machines have been fitted to a tractor and checked thoroughly. However, hose connections can become loose in transit and these should be checked again before the machine is put to work.
4. Operate the arms through the full amount of travel; check all movements are functioning correctly.
5. Place flail head near ground in a safe position and with tractor revs low, select 'start' position for the flail motor.
6. Once the rotor is settled, slowly increase revs of PTO to 540r.p.m. and run for a further 5 minutes. Slowly reduce revs and then disengage PTO.
7. Check all hoses for kinks, pinching, chafing and leaks.
8. Re-check oil level.



Warning

The rotor will take a long time to stop. Never leave the cab until PTO is disengaged, engine stopped and rotor has stopped spinning.

Spearhead 5 Series

Removing from the tractor



The following steps **MUST** be followed in exactly the same order in which they appear, with removal of the top link being the last action before driving the tractor away. Do not attempt to operate machine controls through the rear cab window whilst standing on or amongst the linkage.

1. Select a level firm site such as a concreted surface.
2. Fit parking stands. Place the flail head on the ground approximately 1m out from machine main assembly, to the rear.
3. Ensure head float is discharged and turned off.
4. The arms must be slewed back into transport position and the locking pin fitted to slew post.
5. Disengage PTO.
6. Slightly raise the lower lift arms with great care to enable the stabiliser locking pins to be removed.
7. Lower all weight securely onto parking stands (Fig.1).



Fig. 1

8. Stop engine; ensure all weight is off the tractor and machine hydraulics by operating the levers in all directions.
9. Remove stabiliser bars, lower link pins, PTO shaft and control unit from the cab.
10. Remove top link.
11. Slowly drive tractor away.

Subsequent Attachment to a Different Tractor

Follow the steps for “Attaching your Machine to the Tractor” (page 11).

Spearhead 5 Series

Hydraulic Control

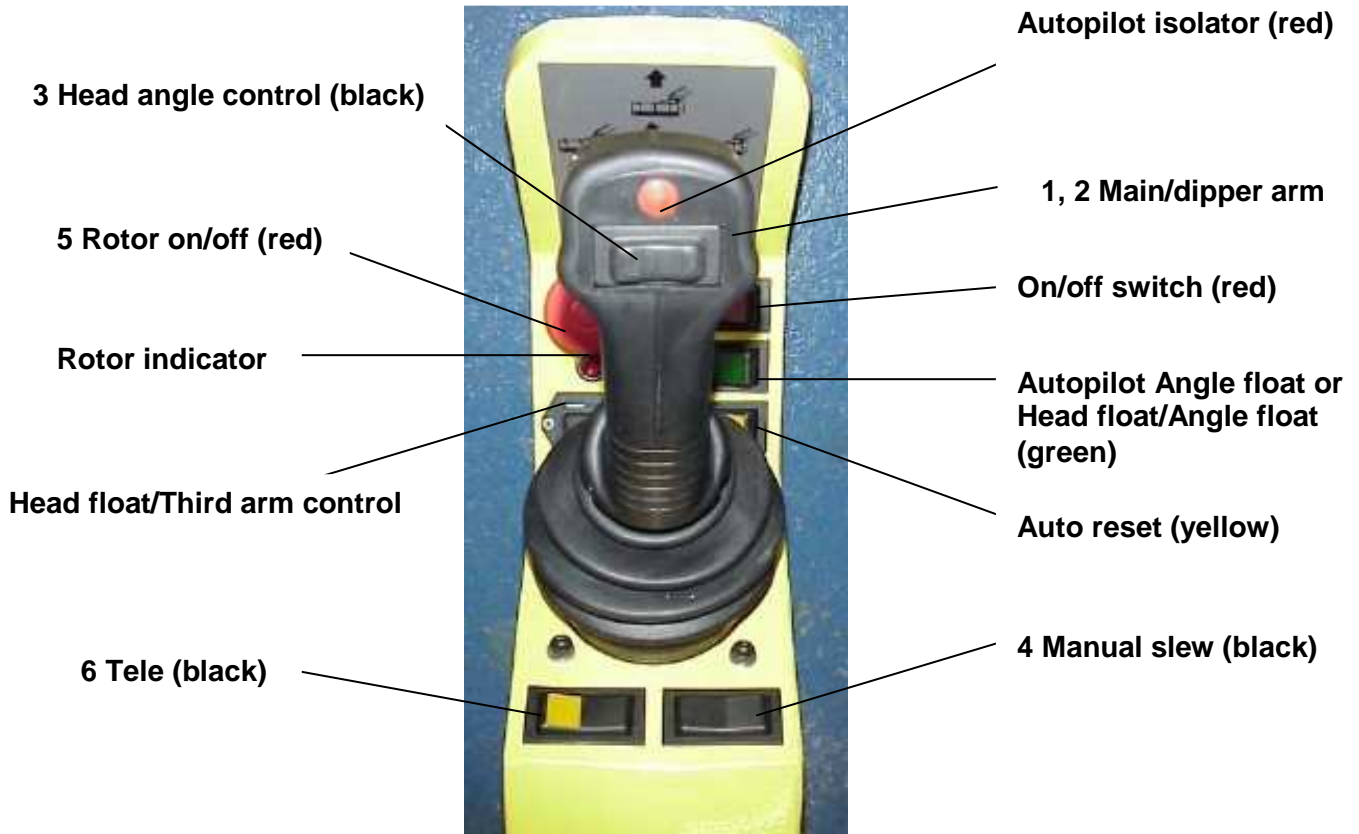

Cable control

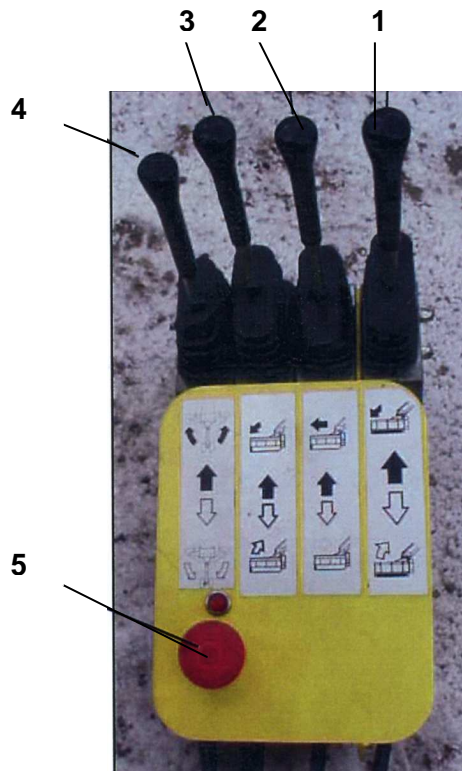

See explanatory diagram on following page.

Spearhead 5 Series

How your controls work

Movements

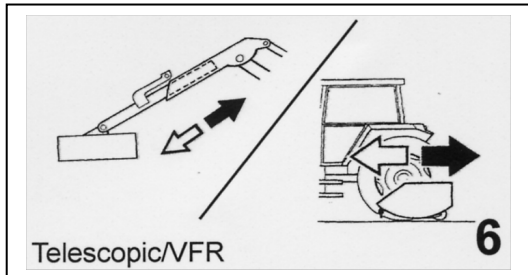
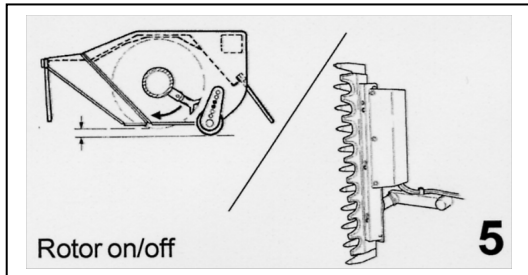
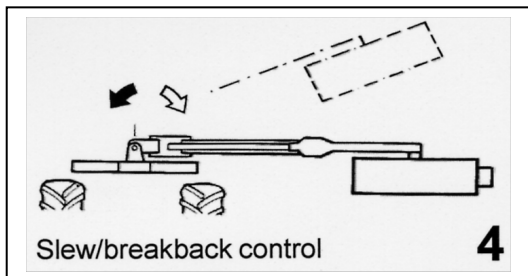
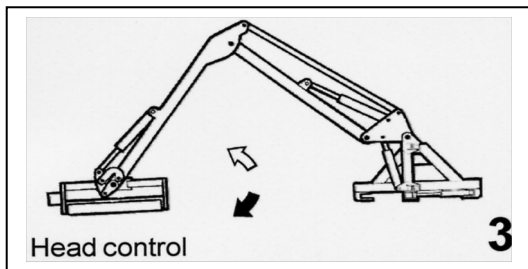
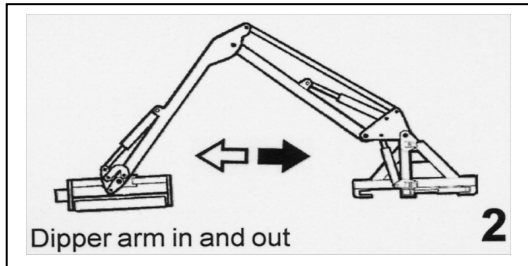
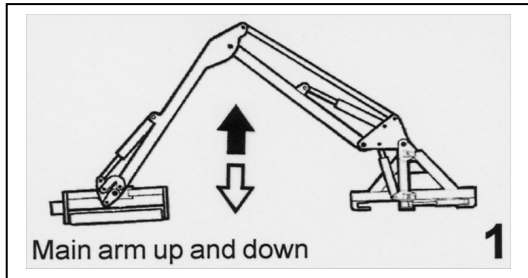

Cable controls

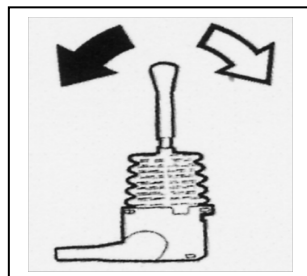
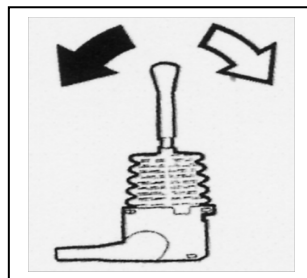
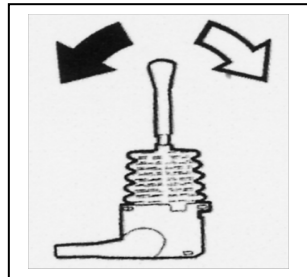
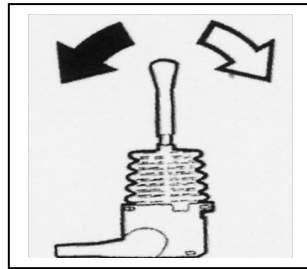

Hydraulic/Electric controls

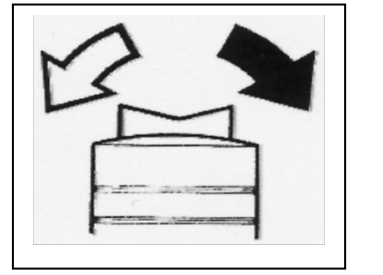
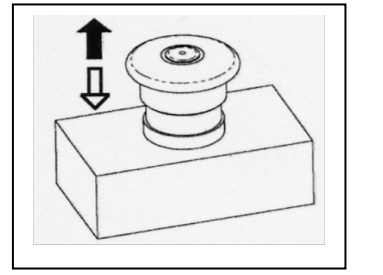
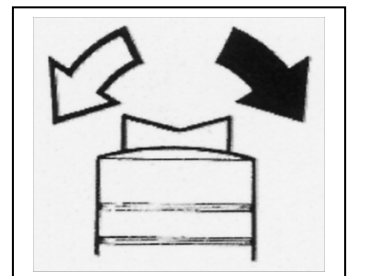
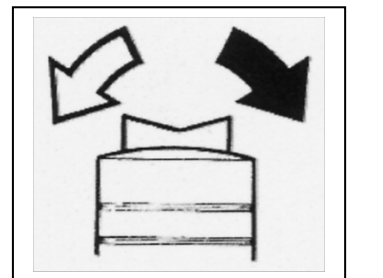
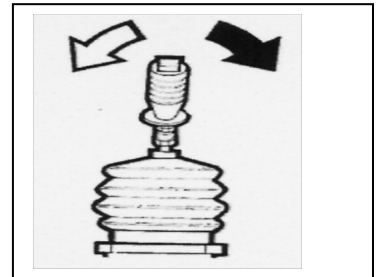
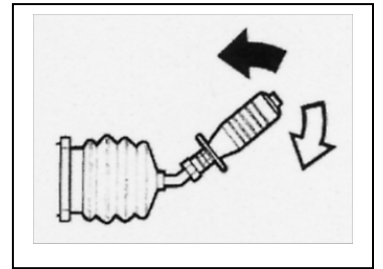

Spearhead 5 Series

Cutting Head Setup

Direct Drive option minimises weight at the end of a long arm, by compact mounting and benefit of reduced maintenance. Running at a single speed of 2700 rpm.

Belt Drive optimises cutting performance with a choice of rotor speeds:

Fast - to provide extra cutting tip speed for fine finish on annual hedge trimming. Slow - to provide extra torque with more power for grass mowing and overgrown hedges.

Cutting Width

Standard 1.2m is suitable for both grass and hedges, and optimises power to weight ratio.

Optional 1.5m is best used for hedge trimming to reduce the number of passes. However, there is less power per flail and an increased weight penalty which is not recommended on long reach machines, and especially not for grass cutting.



Warning

Never attempt to operate the machine without the rear roller correctly fitted. The roller performs a key safety function should the rotor shaft pick up wire. It is essential for operator safety that it remains in place. It is also an essential structural part of the cutting head. Removing it will cause premature wear on rotor bearings and will lead to premature wear on the fabrications.

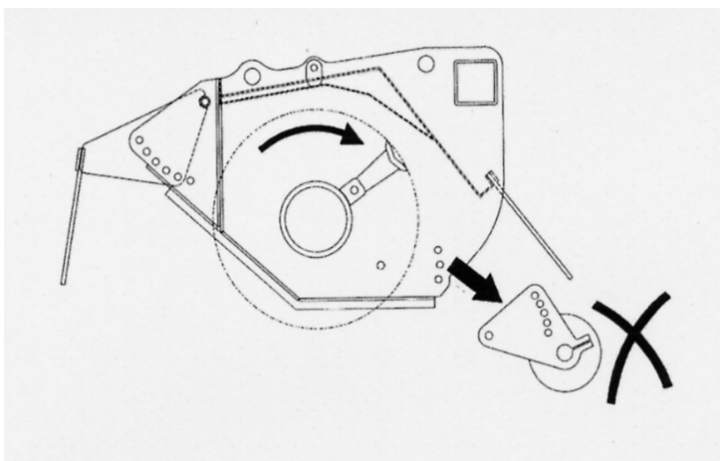

Spearhead 5 Series

Hedge Cutting

Recommended for hedge cutting

- 1.2m or 1.5m rotor
- 5" Rear roller
- "T" flails or "Boot" flails
- Rear flap
- Front flap

Note: The 1.5m head is not recommended on Excel 645 models.

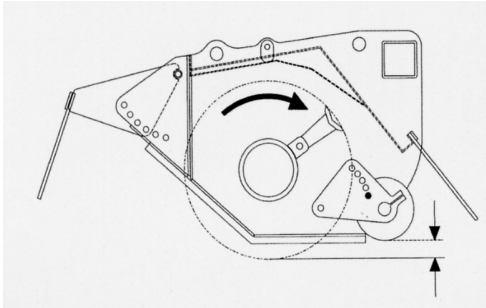

Roller Setup

Roller should be set to just clear the top of the hedge.

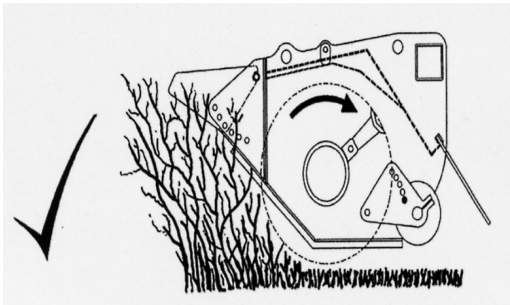

Normal hedge cutting

Flail is cutting upwards reducing flying debris to minimum and leaving a tidy finish. Open adjustable front hood as required.

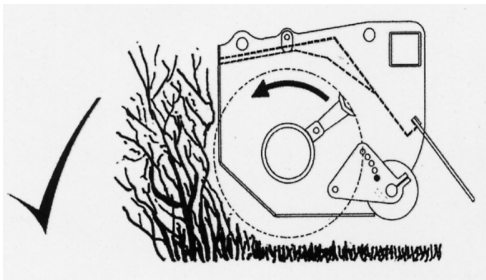

Rough cutting

Reverse rotation and remove front cowling if necessary. Down cut is not good for the hedge and leaves an untidy finish. Only use this position when rough cutting in heavy growth.

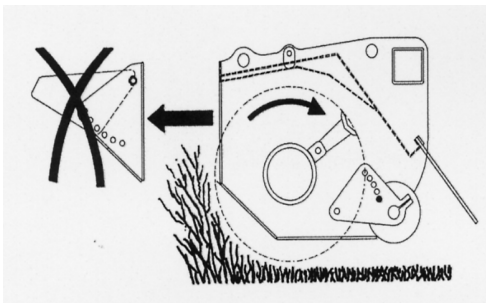

Warning

Seek advice before reversing direction of motor.



Optional belt drive rotor - use smaller pulley on rotor shaft for 3000r.p.m.

Do not remove cowling from the head when cutting "up".

Spearhead 5 Series

Grass Cutting

Recommended for grass cutting

- 1.2m rotor only
- Rear roller
- Cowl wear plate
- "C" flails or "Back to Back" flails
- Optional - "Boot" flails
- Oil Cooler
- Front and rear flap
- Head float and Angle Float
- Auto-pilot
- Fixed front grass cowl

Note: The 1.5m head is not recommended for grass cutting.

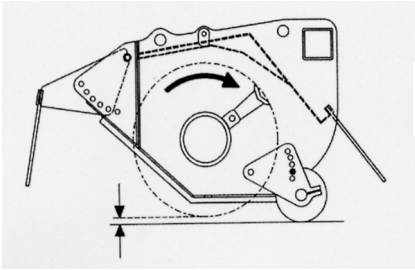

Cutting Height Adjustment

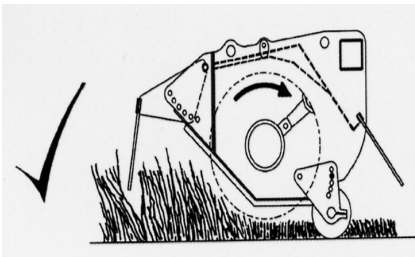
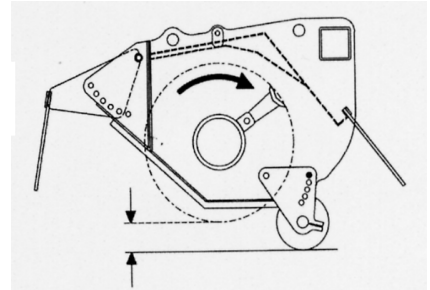

Grass cutting

Set rear roller down to control cutting height. Have rubber flap fitted to the front and rear of head and close down the adjustable front hood to reduce flying debris to a minimum.

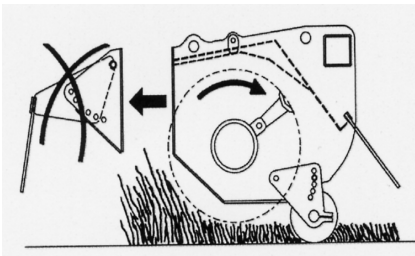

Warning

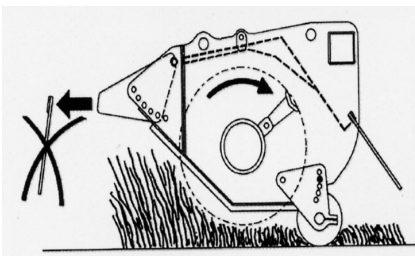

Never remove front cowl.

Do not operate without front and rear flap.

Do not verge mow without a rear roller.

Do not verge mow with rear roller set too high, remember the rear roller is used to control the cutting height.

Optional belt drive rotor

use larger pulley on rotor shaft for reduced speed 2400 rpm and increased torque.

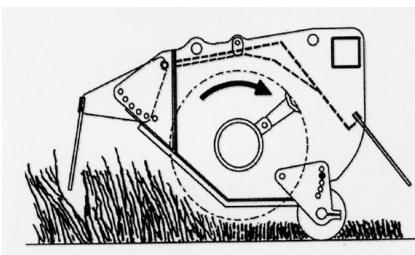

Spearhead 5 Series

Optional Hydraulic Rear Roller

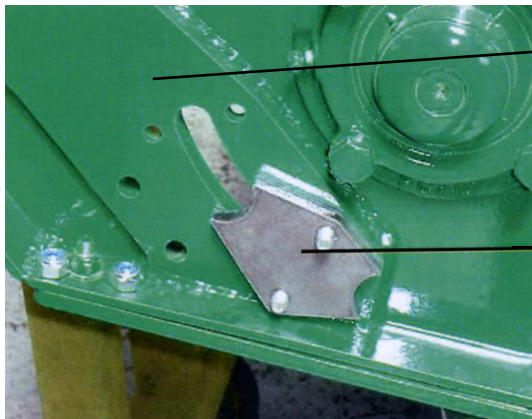

Grease daily

Setup for hedge cutting uses large stops in either position at bottom of adjustment slot.

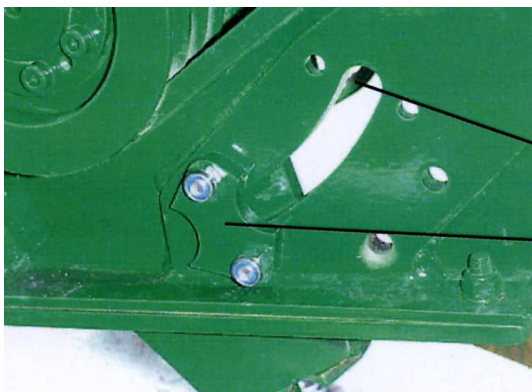

Setup for grass cutting uses small stops in either position, with the option of an additional stop at the top of the adjustment slot.

The hydraulic rear roller is controlled by a switch on the control panel. The control of the rear roller is either raised or lowered; there is no in-between height control. Height is set as above for either hedge or grass cutting.

Hydraulic rear roller control switch. Positions depend on machine options specified.



Note

To ensure the roller moves freely its important to keep the roller Side plates and head cowl clean and lubricated



Attention

When hedge cutter is fitted with reverse rotor direction control the hydraulic rear roller will not function.

To set rear roller when rotor is reversed, bolts supplied must be fitted to holler in position.

Spearhead 5 Series

Operation Warnings



Warnings

Please read all the following operation warnings carefully

- Never drive the tractor with arm out-stretched (except when cutting). When moving from work always first retract arms. Transport with care, metal fatigue is always caused by careless transportation and misuse. If the ground is uneven or bumpy, **slow** down.
- Read this manual and be fully familiar with all operational maintenance and safety procedures.
- Practice in open space without rotor running until familiar with controls. **Take care working the head close to the tractor as it may be possible to strike the tractor.**
- Remember one of the clever features of the Excel & Highway range is its ability to operate within a very narrow space, often within the tractor's width. This will mean it is quite possible for the flail head to foul the tractor. When in confined space the main arm will need to be slightly slewed backwards from normal working position. Practice all these positions and be very familiar with your machine before ever attempting work..
- Never operate above the recommended PTO speed of 540r.p.m. Failure to heed this warning will result in severe damage i.e. reduced belt and pulley life (when fitted); **greatly increased oil temperature**; risk of rotor going out of balance, as well as reduced machine life, and may cause expensive repairs.
- Failure to start and stop the rotor at a low PTO speed or to operate at the correct speed will result very quickly in severe motor and/or pump damage.
- Never attempt to slew arms when fully out stretched - always retract before operating the slew. Be very careful when operating on sloping ground.
- Never attempt to slew arms with the head on the ground, always raise the head before slewing.
- Never attempt to operate the machine while going backwards. It will immediately damage the arms and possibly the flail head. Remember, before selecting reverse gear always lift the flail head out of work and retract the arms towards the tractor.

Spearhead 5 Series

Moving into transport position



Warnings

Always transport machine with the slew locking pin and transport link fitted and their arms closed in their transport position on the bump stops.

Avoid high transport speeds which will cause unnecessary strain on machine and tractor.

Never travel with the reach arm away from bump stop on the main arm. Failure to adhere to this warning will cause damage to ram seals and arms.

Do not attempt to move the main lift ram until transport link has been removed. Failure to adhere to this warning may cause damage to the frame, link or ram.

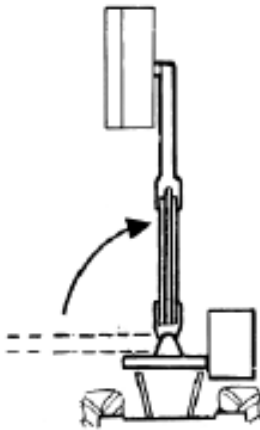

1. Disengage head motor drive

Ensure that lift and angle float are discharged and turned off.

Retract arms to bring fail head approx 1 metre from tractor wheel and 1 metre off the ground (close telescopic or VFR where applicable).

Slew rearwards to fully close slew ram.

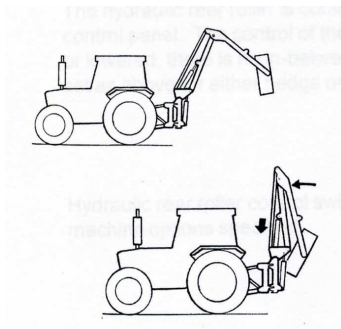

2. Gently close reach arm into cradle and bump stop on main arm.

Spearhead 5 Series



Flip-over transport brkt

3. Fold transport stop over. Carefully position main boom over the tractor cab roof until rubber bump stop meets the flip-over transport bracket.
Warning: Bracket must be in correct position or main boom may over centre and drop onto cab roof.



Transport link

4. Mount adjustable transport link

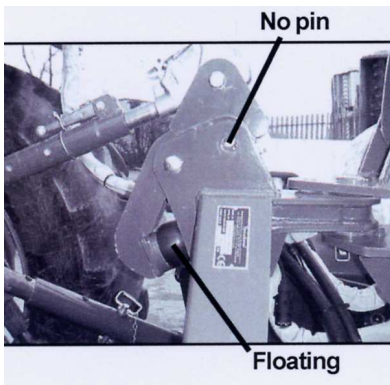

5 Ensure top bracket is able to float by removing second rear pin.



Slew locking pin

6. Fit locking pin into slew frame.

Spearhead 5 Series

Transport to work position

- Remove locking pin from slew post, and then remove the transport link.
- Ensure motor valve lever is off, engage P.T.O. low revolutions.
- Position head 45° to the dipper arm.



- Lower main lift ram only, until main arm is vertical, then fold transport stop back to original position.

- Extend dipper arm outward.
- Slew arm forward through 90°.
- Position head till horizontal, just above ground.



Warnings.

If flip-over transport bracket is not in the correct position, machine damage could occur.

Engaging head drive

- Select 540rpm PTO and run with low engine revs.
- With flail head in safe position move rotor control lever (5) to 'ON'.
- **Cold start** - it is important not to run at full speed with cold oil. Run at low speed for at least 15 minutes to allow oil to warm up.
- Afterwards slowly increase engine revs to obtain correct PTO speed, 540rpm.
- Never attempt to start rotor while under load.

Disengage head drive

- Slowly decrease engine revolutions to a fast idle.
- Move rotor control lever (5) to 'OFF'.
- Never increase or decrease PTO speed rapidly, this could seriously damage pumps and motor.

Spearhead 5 Series

Break back

Manual - Yellow switch “off”

The Excel range of reach mowers have as standard a slew ram to position the machine from transport to work or any position midway for narrow lane cutting. This ram also acts as the break back ram for machine protection should an obstacle be encountered while travelling forward.

The break back will operate if the machine is overloaded i.e. a dense patch of vegetation, too high a forward speed, and when working uphill. The tractor must be halted and the flail head manoeuvred around the obstacle before the break back is reset via slew control lever / switch.

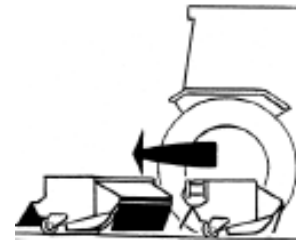

Manual

Recommended for
Confined areas and on steep hills

Auto reset - Yellow switch “on”

This is recommended for normal use either verge mowing or hedge cutting. When auto reset is selected the flail head rises as the arm slews back past an obstacle, once past, the weight of the head causes the arm to automatically slew forward and down to the original position. Therefore, when verge mowing, too much weight on rear roller will cause arm to break back prematurely, as will too high a forward speed and a dense crop.

Under certain conditions it may be beneficial to turn off auto reset and operate break back manually, especially in confined areas and up steep hills.

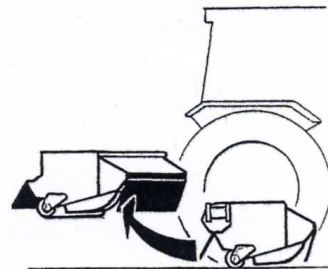

Auto reset

Recommended for
Normal use



Warnings

Never attempt to operate the machine when travelling backwards, the break back will not function and any damage caused will not be considered warranty.

The break back feature does not excuse the machine operator of their need to be aware of obstacles and to avoid hazards. It is your responsibility to maintain a long reliable working life.

Spearhead 5 Series

Tractor forward speed

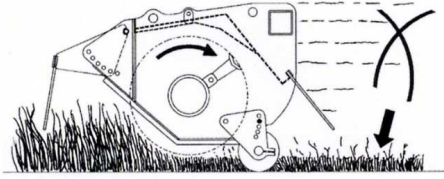

Too high a forward speed will impair the finish, leaving it looking ragged, cause over frequent use of the break back, and overheat the oil.

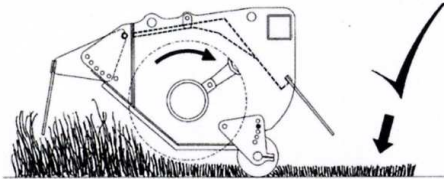

A slower forward speed improves the standard of the finish.

Cutting sequence

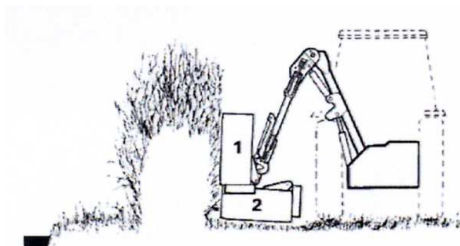

Cut field side and bottom of hedge first.

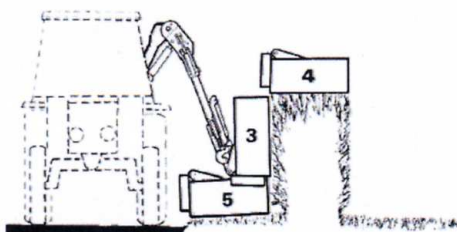

Cutting hedge from roadside

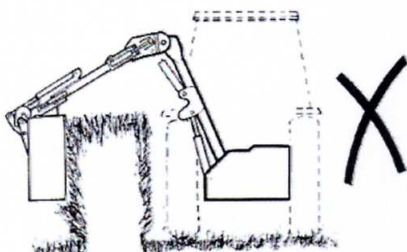

Warning

Never operate with flail rotor facing towards the tractor. This is potentially dangerous with debris being thrown towards the tractor, and unseen hazards may cause damage.

Spearhead 5 Series

Wire Trap

This is located under the front hood. It must not be interfered with in any way.

Any wire must be removed immediately.

Lower rotor to ground, select rotor control lever to 'off' and wait until rotor stops spinning. Disengage PTO and stop engine before leaving cab.



Warning

Wire is extremely dangerous and must be avoided at all times. Inspect work area before commencing, removing all loose wire and clearly marking fixed wire.



High voltage cables

Always be very aware of overhead cables. Between poles wires can be well within reach of the machine. If in any doubt of the danger, consult your local electricity company regarding a safe procedure for work.

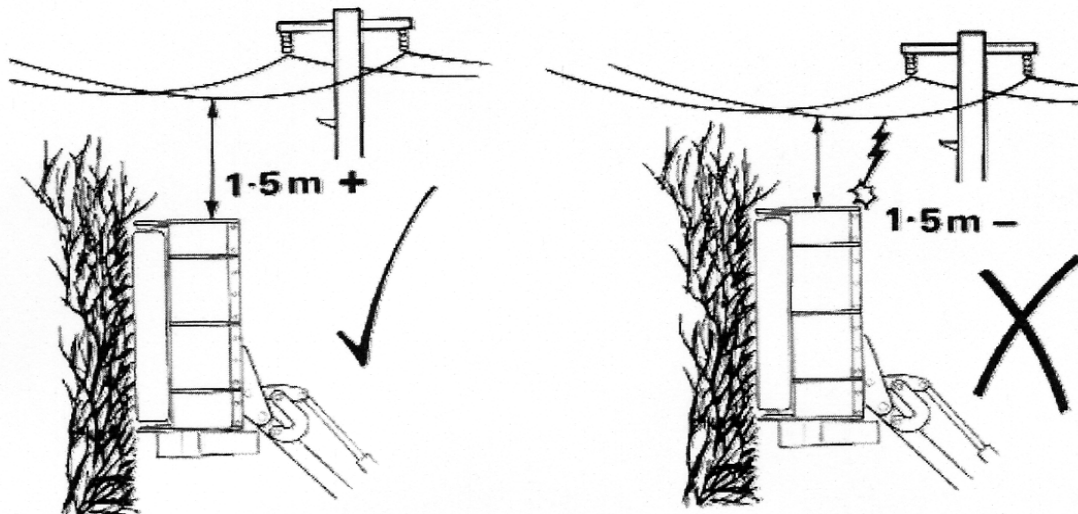

Spearhead 5 Series

Optinal - Head Float



Hydraulic Controls

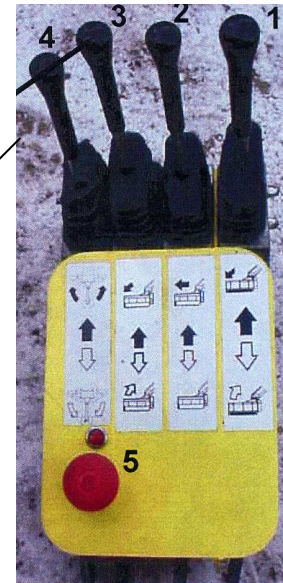
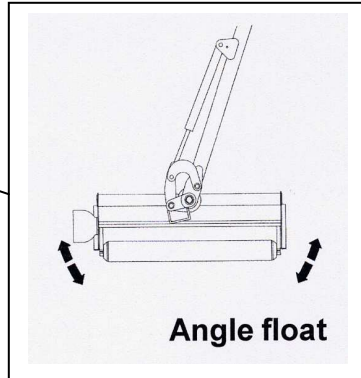

Cable Control

This option allows the flail head to follow contours of the ground without having to constantly control the angle of the head.

The centre of balance is the best mounting point for the head if head float is to be used properly.

Operating the head float

Place flail head on the ground and switch on head float control, this opens the head ram to tank, and allows the ram to float in or out, maintaining full contact with the ground automatically.

To regain manual control switch off.



Warning

Do not fold the machine up for transport before turning off the head float.

Spearhead 5 Series

Optional – Arm float

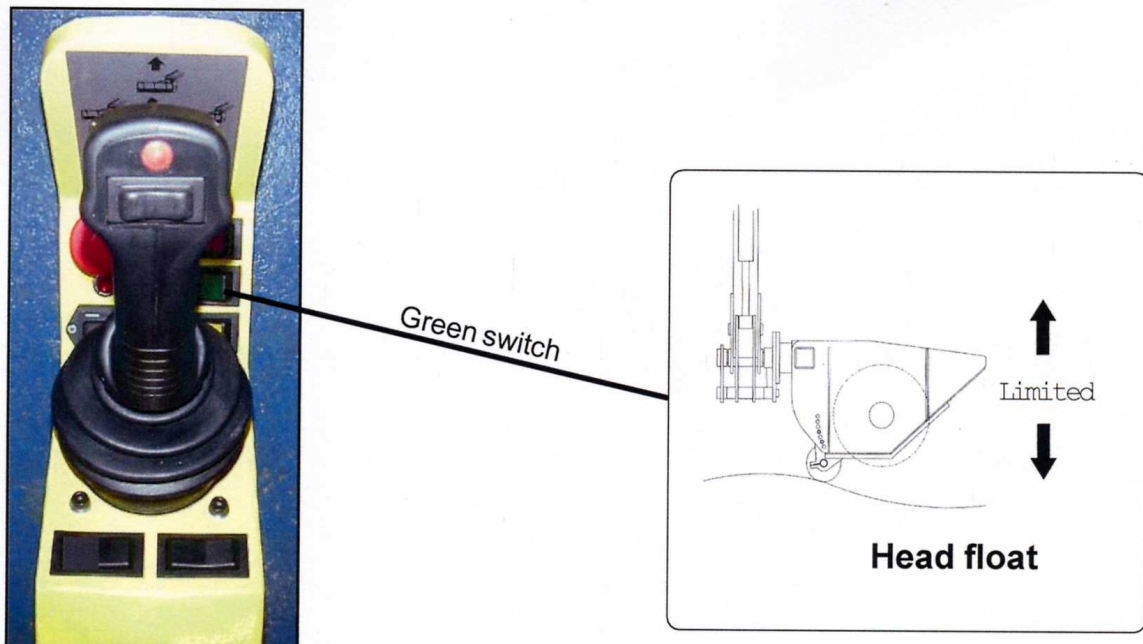

This is only to be used in verge mowing set up, it will reduce weight on the rear roller allowing head to move more easily, following small changes in ground contours in a forward motion, with the aid of a pre-charged gas accumulator.

Operating the arm float

To select arm float, first lower cutting head to the ground, disengage PTO and stop tractor engine. Main Lift control lever should be operated to take a proportion of the flail head weight off the rear roller. This is important, as too little weight on the rear roller will leave uncut areas of grass, too much weight on the roller will cause scalping in places and increase flail wear and damage. We strongly recommend the use of auto reset - break back.

When the head is pushed further out more weight will be applied to the accumulator causing the head to drop, reset with control lever.

As the ground contours alter it is necessary to reset the pressure within the main lift circuit as above, constantly raising or lowering control lever.



Warning

Do not fold the machine up for transport before turning off the arm float.

Spearhead 5 Series

Optional - Debris blower

Description of the Debris blower

Hydraulically driven fan from tractor external services, please quote tractor oil flow when ordering (maximum 40lt per min).

The return oil must go to a free flow connection i.e. filler plug. Avoid quick release couplings.

Operating the Debris blower

The fan is suitable for clearing cuttings off the highway, we recommend the blower is used on final cut only and not continually on.

Excessive use may cause overheating. The unit can be angled for the best effect.

Transport

The blower housing protrudes and care should be taken not to damage unit.

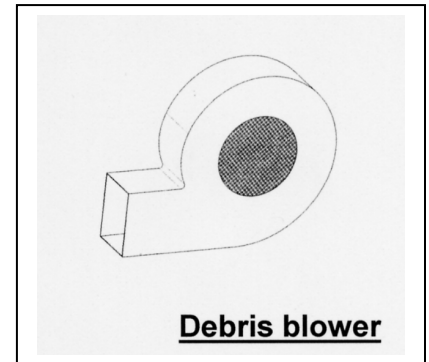

Optional – Oil cooler

Prolongs the life of the hydraulic oil and components in hot and arduous conditions.

We strongly recommend an oil cooler when verge cutting.

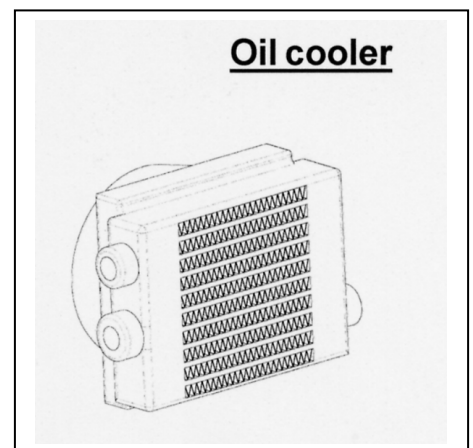

Note

The oil cooler requires a separate electrical supply direct from the battery. The fan is independently controlled by a thermostat (50°C) mounted in the oil tank.

Spearhead 5 Series

Optional - Autopilot

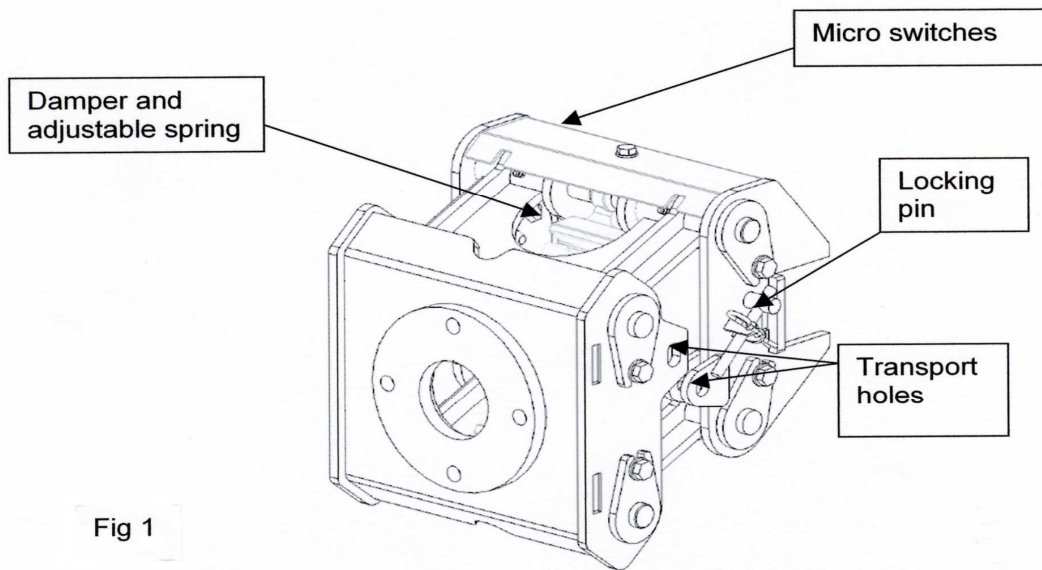

Fig 1

Introduction to the Autopilot

The Spearhead Autopilot is an automatic control system for use when cutting on the ground. It operates by sensing the weight on the rear roller and maintaining this within a narrow band without the attention of the operator. When the angle of the area being mown is more than 45 degrees to the horizontal, it is best to switch off the Autopilot and operate the machine manually until the angle becomes more normal. The middle position of the green switch will allow angle float without autopilot.

Autopilot will only operate when the cutting head rear roller is in contact with the ground.

If the machine is going to be used for long periods of time at hedge cutting it is recommended to remove the Autopilot assembly between the dipper arm and head and replace with standard head bracket (Part No. 1777315A).

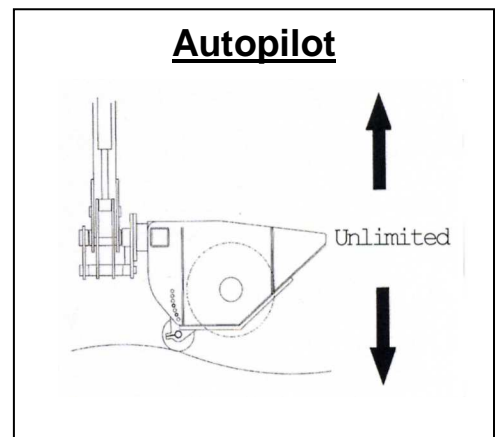

Warning - To adjust the Autopilot, the Operator must remove the panel mounted fuse on the control panel, which isolates the rotor (see right).



Ensure you fully understand the operation of the Spearhead Autopilot, which will reduce machine and operator fatigue and improve hourly output, machine life, standard of work and comfort to the operator.



Warning

Ensure the engine has stopped and the key is removed, the PTO is disengaged, handbrake secure, and the head is firmly on the ground before attempting any servicing, maintenance or adjustment.

Spearhead 5 Series

Optional – Autopilot

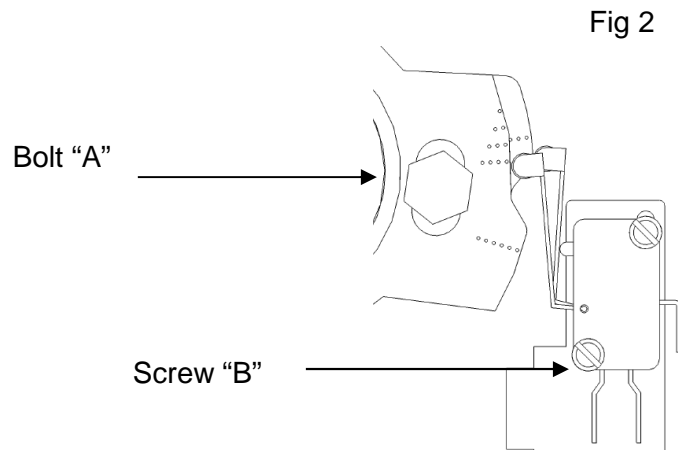

Set-up: Correct position of micro switches

1. Place rear roller on the ground
2. Ensure the locking pins (fig.1) are installed into the Auto-pilot with the arm fully lowered
3. Engine turned off, key removed and PTO disengaged.
4. Slacken bolt ("A" fig 2) and adjust cam plates until they are flush on the top.
5. Slacken screws ("B" fig 2) to adjust switches; the lever arm must rise on the cam as shown sufficiently to make the circuit. The switch will give an audible click, if necessary bend the lever arm towards the cam to ensure the switch makes a circuit.
6. Remove the locking pin from the auto-pilot and raise the main arm and rear roller off the ground 0.5 m, now check the opposite switch has risen up the other cam and the switch has made a circuit.
7. Remove the fuse mounted in the control panel and start the machine, turn on the rotor switch (the rotor should not spin) and turn on the autopilot. The arm should rise if the arm head was fully lowered or drop if the rear roller is off the ground, and the 2 switch arms should come to rest in the valley between each cam peak.
8. The system can be checked for operation by depressing the red isolator button on the top of the joystick handle, fully lowering the main arm, bring joystick to neutral and releasing the red button. The autopilot should now reset the arm up until the switches rest in the valley.

Summary

You must ensure that the micro switches make and break a circuit as the cams rotate through their arc of travel. It is very important to correctly set the micro switches to ensure the electrical circuit functions, the switch lever arm must follow it's own cam and not be influenced by the opposite cam also the lever must be bent towards or away from the cam to allow the electric circuit to open and close in accordance to the cam position.

Spearhead 5 Series

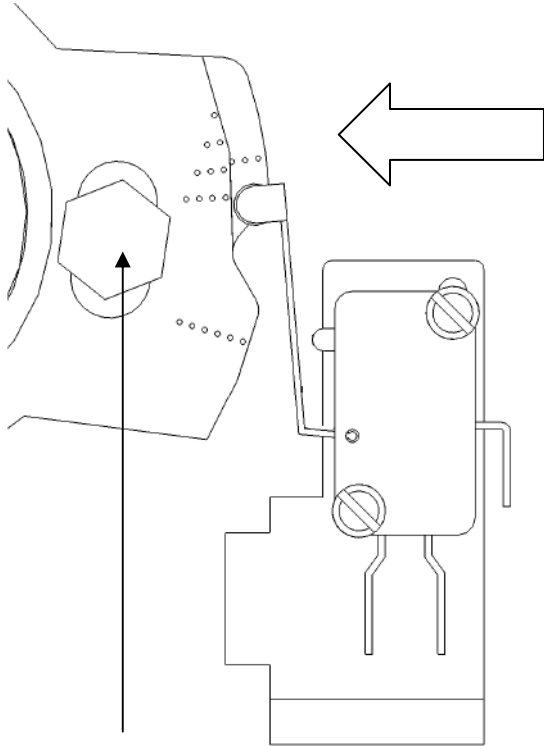

Auto Pilot

When both switches are open the main arm will hold position, this is neutral or mid position when they rest in the valley between both cam peaks.

Slacken this bolt before adjusting the position of cams, increase sensitivity by moving the cam peaks together reduce auto pilot sensitivity by moving them apart. We recommend the cam plates are flush at the top as shown.

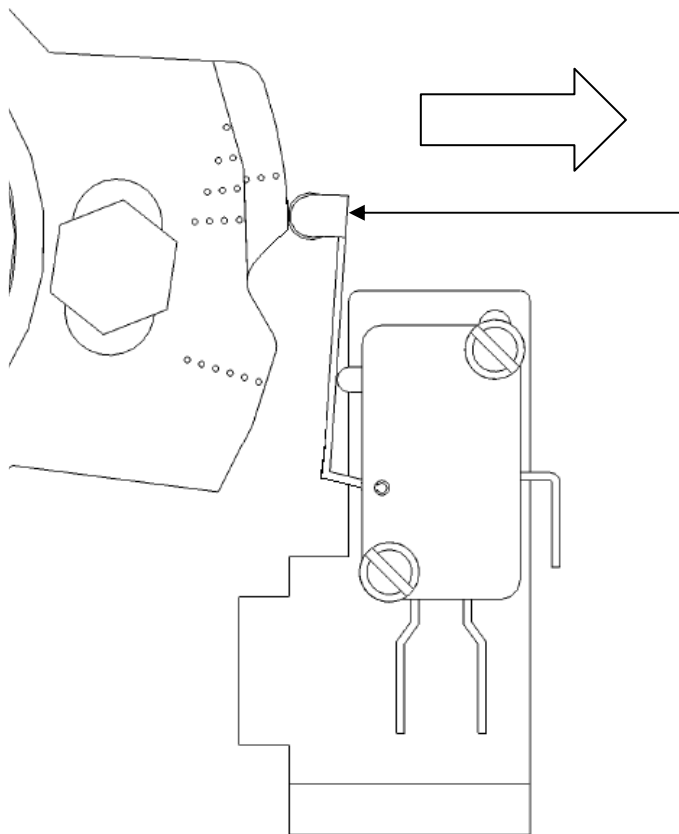

Ensure the switch lever closes the contacts, if not adjust by bending the lever arm towards the cam.

Auto Pilot

When one of the switches is closed, main arm will either raise or lower dependant on which switch has been triggered.

Spearhead 5 Series

Auto pilot switch alignment

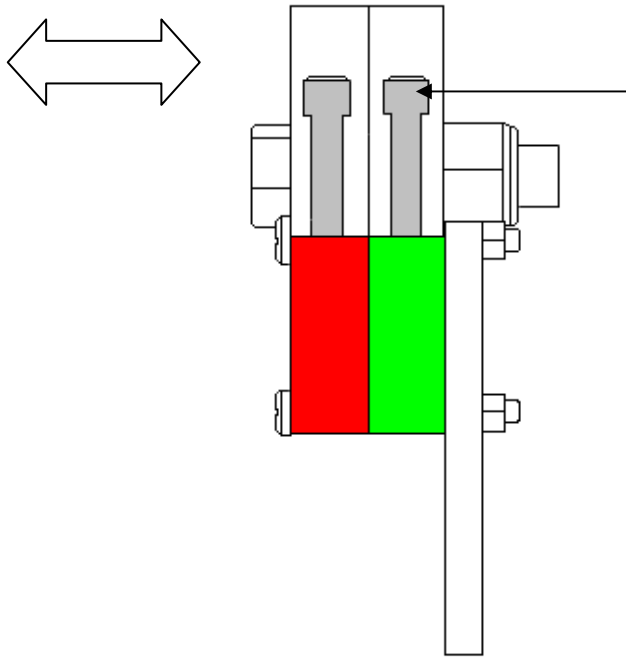

Bend lever arm of switch to align with the middle of each cam, ensure they don't overlap onto the adjacent cam.

Alternative settings

Move cams apart to increase amount of weight carried on the rear roller, there by reducing the sensitivity of the auto-pilot

If the cams are to close together the switches will constantly be altering the main arm height causing unnecessary wear and strain on the hydraulics

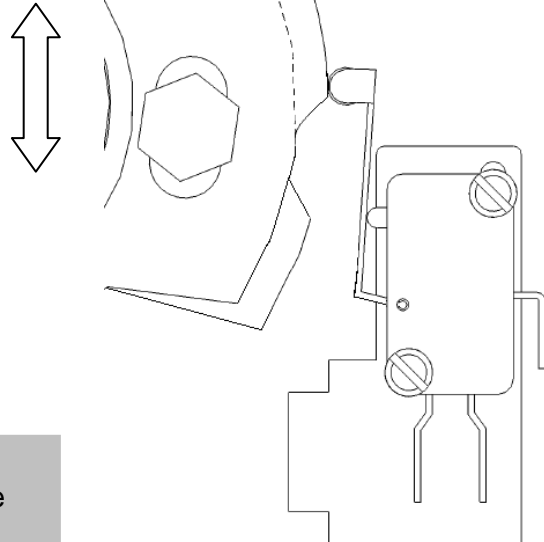

Warning

If the working range is altered the spring length on the damper may need adjusting to compensate.

Note

The basic factory setting for the spring length is 200mm

Spearhead 5 Series

Operation of the Autopilot

To activate Autopilot first slew the head into work position and lower the head horizontally onto the ground.

Remove the 2 transport pins. Raise the head 300 - 400mm off the ground and ensure Auto slew is switched on, engage rotor drive and then switch on Autopilot. The head will gently drop to the ground and be ready for work.

Your forward speed will be determined by ground conditions, density of growth, height of cut and generally operating within a safety margin to allow you time to react to any unexpected occurrence.

Once in work the Autopilot will control the head height and angle, allowing the head to accurately follow all the ground contours. The operator will control reach whenever necessary.

The Spearhead Autopilot will assist you with grass mowing. It does not relieve you of your responsibility to drive with care and understanding for the machine.

When crossing "grips" or drainage gullies, it may be necessary to temporarily lift with the main ram using hydraulic joystick and the red isolator button.

If you approach larger areas not to be mown i.e. road junction, bridges and crash barriers, it will be necessary to switch off the Autopilot, enabling you to raise the head from the ground.

Before switching on the Autopilot please ensure the head is within 300 - 400mm from the ground. Always ensure that the Auto-break-back is switched on when operating with the Autopilot.

Transport of the machines with Autopilot

1. Turn off autopilot switch (green)
2. Ensure all locking pins are fitted to mainframe, slew, height stop and auto pilot bracket.
3. Ensure machine is folded to the recommended position
4. Turn off isolator switch (red)
5. Disconnect electrical supply.
6. Disengage PTO



Warning

Autopilot is not suitable in extreme conditions i.e. very steep banks and very wet conditions. Always ensure the rear roller is not "clogged" with mud. If the machine starts to move uncontrolled, isolate by turning off the green switch place the head on the ground, follow point 4. 5 and 6 above. Turn off the tractor, apply parking brake and remove the ignition key. Inspect machine for fault.

Optional – Quad saw



Quad saw

Important Safety Considerations

- Never operate the machine with other people present, as it is possible for debris to be thrown from the saw blades in all directions.
- Always ensure all cab safety guards are in place and all tractor windows are closed. Never allow an inexperienced person to operate the machine without supervision.
- Never allow children to play on or around the machine at any time.
- Never attempt any maintenance or adjustment without first disengaging the PTO/ hydraulic pump, lowering the head to the ground, stopping the tractor engine and applying the tractor's parking brakes. Before leaving the cab remove the ignition key, never stop the engine with the PTO engaged
- Before leaving the tractor cab always ensure that the saw head is firmly on the ground, no weight is on the tractors hydraulics and blades have stopped spinning.
- Always check that all guards are properly fitted, check there are no damaged or loose parts.
- Always operate the blades at a speed between 3000 - 3200 R.P.M.
- Maximum oil pressure of 250 bar in the hydraulic hoses.
- Never transport without the blade protection guards mounted.
- Always inspect work area for wire, steel posts, large stones and other dangerous materials. If such items are found, remove them.
- Never attempt to use the machine for any purpose other than that it was designed for.
- Ensure that all warning labels are always visible and that they are not damaged, defaced or missing.
- PTO speed 540 R.P.M.
- 10 MICRON ABSOLUTE FILTER: Before fitting Quad saw to machine, remove existing filter element and replace with above filter element (o. 3900068A).

Failure to comply will invalidate your warranty

Spearhead 5 Series

Optional – Quad saw

Technical Data and Description

Each shaft is driven by vee belts, and the whole unit is powered by a hydraulic motor. Branch carriers are placed between the blades.

The Quad saw is supplied with a special bracket enabling mounting on various vehicles and machines.

Frame with 4 shafts.	Working width	2000mm
	Blade speed	3000 - 3200 R.P.M.
	Blade diameter	500mm
For mounting on hydraulic hedge cutters	Teeth per blade	72
	Materials	Hardened steel with special teeth HM precision blade
	Performance	1 - 120mm branch diameter
500mm saw blades	Application	Vertical
	Relief valve pressure	Max. 120 atmospheres/bar
	Filter element	10 Micron absolute

Belt Diagram - Quad saw

It is important that the belts are correctly mounted and tightened. When new belts are mounted they must be tensioned to 700N for the short and 900N for the long belts.

After 10 to 15 working hours the belts may have slackened and must be checked.

Beware! The tension has now changed to 550N for the short and 650N for the long belts.

Contact the Spearhead Service department if you have any questions.

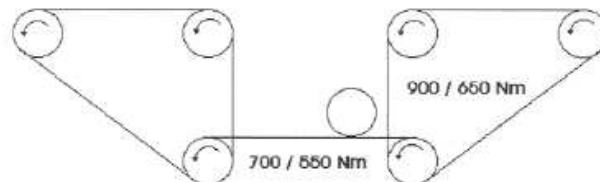

Mounting of the Quad saw

Blades to be fitted using hex head bolts and circular blade plates supplied. Square plastic wear blocks to be fitted between quadsaw frame and blade.

It is very important that the blades are mounted in a downward cut rotation (Fig. 1). Always use the blades vertically positioned in relation to the direction of travel (Fig. 2).

The hydraulic hoses must be connected correctly to achieve the correct direction of rotation. Return hose is fitted with one way valve and usually connects to the top hose that runs along the arm.

Drainage hose must be lead directly to the oil reservoir. Daily inspect all hydraulic hoses and fittings for damage or leaks.

Connection and disconnection of hoses must be carried out in a contamination free environment.

When starting for the first time the speed of rotation on the blades must be measured (3000 - 3200 R.P.M.). This rotation should be maintained to ensure optimum performance.

Spearhead 5 Series

Operating instructions

It is recommended to travel forward slowly when starting work in order to maintain the correct speed of the blades. Adjust the angle of the saw to present the branches approx 90° to the blades. Always ensure the blades are vertical to allow cut branches to fall away. If a large branch is approaching adjust the working height to ensure it meets the centre of a blade.

Do not use horizontally there is a danger the weight of the cut branches will bend the blades, however 45° is permitted for trimming material up to 40mm diameter.

The Quad saw will cut up-to 100mm maximum, branches over 80mm must be cut one at a time, pausing forward travel to allow the saw time to cut each branch.

In the event of small twigs or debris jamming the saw blades, stop the machine immediately and clear the blockage with a suitable tool.

Ensure there is a skid mounted on the bottom of the saw attachment to protect the lowest blade from striking the ground



Warning

Take care not bend the blades in storage or during work. The blades must be inspected daily for signs for fatigue and cracking, do not use the machine with damaged blades they must be replaced immediately.

.Before starting the saw for the first time after connecting the hoses, you must ensure the hydraulic motor is primed with oil and the case has filled with oil, via the small hose connection. Failure to fill the motor case with oil will lead to seizure due to lack of lubrication.

Note

To change rotation of motor exchange the position of the pressure/returns hoses and the anti-cav valve with the plug.



Spearhead 5 Series

Optional – Telescopic Arm

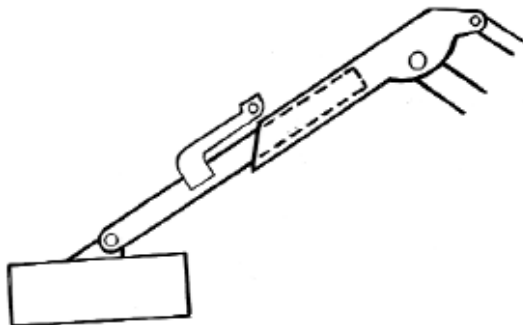

Description of the Telescopic arm

Telescopic extending arm provides extra reach, particularly useful for deep ditches, banks and for reaching high hedges.

Operating the Telescopic Arm

Use the electric switch to adjust the length of the extending telescopic dipper arm to suit working conditions and use dipper ram to vary reach as required.

Over frequent use of telescopic arm will cause premature wear of adjustable pads.

Transport of the Telescopic arm

Always fully retract before folding machine arms into transport position.

Maintenance: Ensure metal boom is clean and lubricated. We recommend a regular application of "Waxol", a car under body protection.

Adjust wear pads as required, screw in until they contact the steel boom, then back off ½ a turn.

Spearhead 5 Series

Optional – Narrow Lane Bracket

This option enables the machine to operate within the width of the tractor by partially slewing the main arm back and altering the pitch of the head.

The narrow lane bracket is powered with a hydraulic ram via the tractor's external spool services.

Note: When not in use and during transport the locking pins should be fitted.



Warning

Do not angle the cutting head so that debris is ejected towards the tractor.

Optional – Reversible Rotor

This option allows the operator to change the direction of rotation of the flail rotor shaft via an extra 3 position valve mounted on the oil tank.

The machine must be stopped and the rotor stationary before the valve is moved forward to reverse, or vice versa.

We do not recommend remote operation via cables from tractor cab to reduce the risk of accidentally changing direction when rotor is turning, this will cause severe damage to the hydraulic pump and rotor.



Warning

Always ensure all safety guards are in place and in good condition. Always keep the windows closed on the cutting side

Spearhead 5 Series

Service & Maintenance



Warning

Before you attempt to do any repair, service, maintenance or adjustment on your machine, ensure the engine has stopped and the key is removed. P.T.O. is disengaged, handbrake secure, and the head is firmly on the ground.

Greasing/Lubrication Points

All the following grease points need to be greased daily

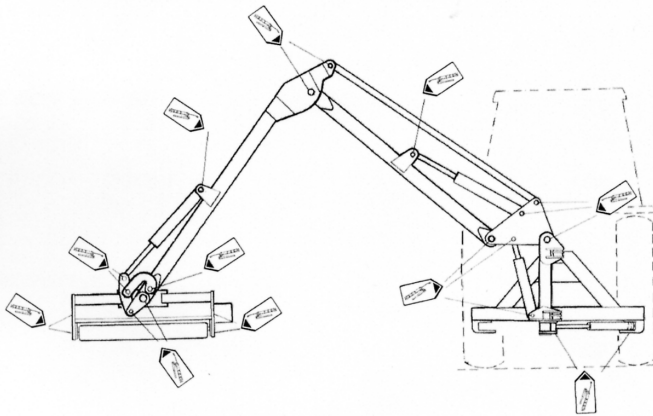

Excel/Highway machine

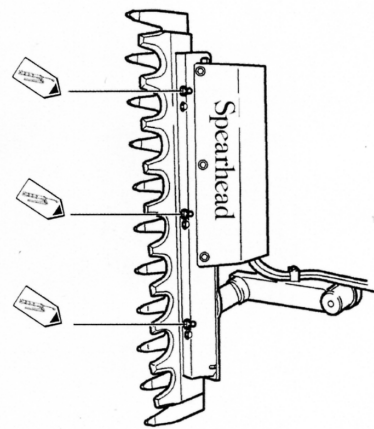

Optional - Cutter bar

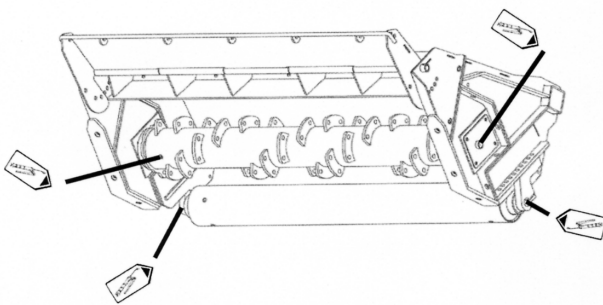

Head Rotor & Roller



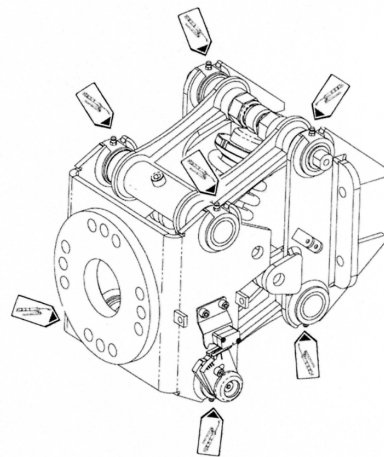







Grease 1.2m head every 8 hours (5-10 pumps)





Optional - Autopilot

Spearhead 5 Series

Lubrication Chart

	Daily	Weekly	Monthly
Rotor shaft bearings			
PTO shaft bearings			
PTO shaft tubes			
Pivot pins			
Roller bearings			
Oil tank			
Gearbox			
Belt drive head			
Flail head			

Key: Grease =  Oil =  Check = 

Greasing / Lubrication

Washing your machine

Grease all your machine and optional parts after each time you wash your machine.

Gearbox

Gearbox oil level / quantity 380cc. Replace after 50hrs then once a year with EP90.

Note: Do not over tighten filler / drain plugs as this will damage gearbox casing.

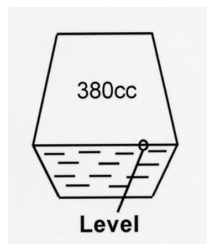

PTO

Dismantle, clean the input drive shaft sliding surfaces and re-grease, failure to do this will result in serious damage to the gearbox. Grease both U.J. joints every 8 hours.

Motor Drive - Direct Drive

Motor drive splines are lubricated via the rotor bearings and should be greased every 8 hours with 10-30 pumps of grease.

Motor Drive - Belt Drive

Motor drive splines are lubricated via the pulley shaft and should be greased weekly with 1 - 2 pumps of grease.

Oil requirements

Fill the tank to centre of sight gauge with approximately 200 litres of Texaco Rando HD46 or equivalent oil. Do not over fill.

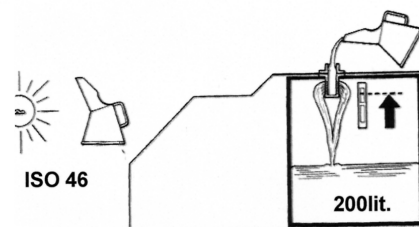

Spearhead 5 Series

Service and maintenance

Hydraulic hoses

Carefully check condition of all hoses during routine service, paying particular attention to chafed outer casing. Securely wrap with waterproof adhesive tape to stop the metal braid from rusting.

Daily inspect all hydraulic hoses and fittings to be in good order. Any damages or leaks must be rectified immediately, this is part of the daily maintenance and it is your responsibility to help ensure a long reliable working life. Spearhead provide a tool kit to enable hoses to be tightened as part of routine maintenance.

Hoses with damaged metal braid should be replaced.

When replacing hoses, quote number stamped on fitting at one end. The Spearhead hydraulic system works at very high pressure. Use only genuine hoses, a burst hose could be very dangerous.

Always replace hoses in exactly the same way they were removed, and to avoid twisting during fitting use two spanners to slacken and tighten.

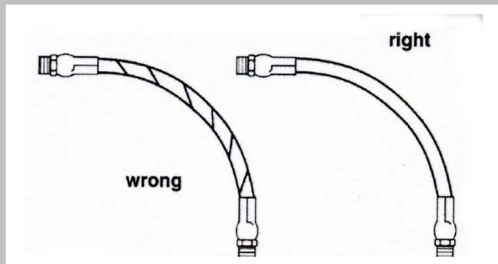

Warning

Hose is weakened when installed in twisted position. Also, pressure pulses in twisted hose tend to fatigue wire and loosen fitting connections. Design so that machine motion produces bending rather than torsion.

Always check the yellow protective sleeving is in good order, replacing sleeving is far cheaper than replacing expensive hoses.

Hose warranty is limited to replacement of hoses due to faulty materials or manufacture. Warranty will not be considered on hoses damaged by chaffing, abrasion, cuts or pinching while in work, or to damaged threads due to over tightening.

Recommended torque settings for nut

BSP (size)	Tightening (Nm)	Torque (lbs/ft)
1/4"	24	18
3/8"	33	24
1/2"	44	35
1/4"	84	62
1"	115	85

Recommended torque settings for hose unions in conjunction with bonded seals

BSP (size)	Tightening (Nm)	Torque (lbs/ft)
1/4"	34	25
3/8"	75	55
1/2"	102	75
3/4"	183	135
1"	203	150

All hose connections are of a "Parker" soft seal type and only need 1/2 a turn more than finger tight to become leak proof. When dismantling, the hose should be manually flexed to relieve any pressure, and the retaining nut slackened before complete disassembly.

Spearhead 5 Series

Service and maintenance

Oil supply

- Daily before starting up check oil level in tank reservoir.
- It is a good practice to constantly keep an eye on the tank level gauge, (this can be seen from the tractor seat) as a pipe burst could empty the tank within minutes.
- A pump or motor which is starved of oil will be damaged beyond repair.
- Replace oil if signs of contamination occur (discoloured)
- Contamination can be reduced by:
 - Thoroughly cleaning around reservoir cap before removing.
 - Using a clean container when replenishing the system.
 - Regularly servicing the filtration system.
 - Never allowing oil level to fall below the sight gauge.
- Daily inspect all hydraulic connections and fittings. Any damage or leaks must be rectified immediately, this is part of the daily maintenance and it is your responsibility to help maintain a long reliable working life.
- When tightening fittings always use two spanners when necessary and do not over tighten. If a fitting persists in leaking it will need to be replaced.

Oil Recommendations

Oil Supplier	Description
Texaco	Rando HD 46
	Rando HDZ 46
Esso	Univis N 46
Shell	Tellus 46
	Tellus T46
BP	Bartran 46
	Energol HLP-HM 46
Castrol	Hyspin AWH-M 46
Total	Equivis ZS 46
Elf	Hydrelf HV 46
	Hydrelf XV 46

Filtration maintenance

The machine is protected by a suction strainer and a low-pressure full flow return line filter.

1. The suction filter is permanently fixed in the reservoir tank. Should symptoms of pump cavitation or spongy operation occur the tank must be drained, and the tank and suction filter thoroughly cleaned and dried before refilling with clean oil.
2. The return line filter element should be replaced after the first 50 hours and thereafter at 300 hour intervals. It is most important to replace the filter within these intervals because once blocked, oil will bypass the filter element unfiltered, causing pump & motor damage
3. On electric and hydraulic proportional controls the mini filter must be replaced at 300 hour intervals.
4. If any failure or replacement of hydraulic parts have occurred then the return line filter must be replaced immediately.

Spearhead 5 Series

Service and maintenance

Flail head

- Grease all bearings daily
- Check there is no wrapping of string, plastic, grass or other debris on rotor shaft and rear roller bearings.
- Check the condition of flails and ensure all retaining bolts are tight. When flails are replaced care must be taken to maintain balance of rotor shaft, do not change to a different type.
- Flail retaining bolt and nut torque setting is 200Nm.
- Flail head is supplied centre mounted to get best travel on crowd ram.
- Never operate with any flails missing. This will cause severe vibration and lead to rapid bearing wear and quickly cause the head to crack.
- Blunt flails leave an untidy finish and absorb excessive power, when re-sharpening always wear protective clothing and goggles.
- When flails are showing severe wear, damage or cracking, they must be replaced immediately. Never attempt to weld the flails as this will make them very brittle and extremely dangerous. Do not take risks with the cutting flails, if in doubt replace.
- When replacing flails always replace bolts, nuts and bushes with new.
- Regularly check that all rotor bearing bolts and hydraulic motor retaining bolts are tight.
- With a new machine or if new bolts have been fitted, particular attention needs to be applied to regular tightening of the new bolts. (1hr - 4hrs then daily).
- Check the condition of drive belts, ensuring they are aligned and properly tensioned to avoid any unnecessary belt wear. Remove guards for access to both adjusters when tensioning belts, and ensure belts are running in line after adjustment.

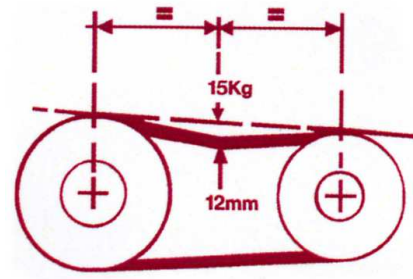

Spearhead 5 Series

Service and maintenance

Cables

Care should be taken during installation and operation to ensure the cables are not trapped or kinked.

Correctly adjusted cables will position the lever with equal amount of travel in either direction from neutral.

It is recommended to pack with grease all moving parts of cable operated spool valve, especially the motor control, to ensure reliability.

Pins and bushes

All main pivot points are furnished with replaceable pins and bushes. If there are any signs of wear, these must be replaced. All parts are available from Spearhead Parts Department.

The pins are secured with a nut and bolt through the head to prevent turning. A retaining washer and screw are clamped to the base of the pin to prevent spreading and must be kept tight (use locking compound).



Warning

Do not use grease containing Molybdenum disulphide on nylon bushes and wear pads.

Storage

Before storing away, thoroughly wash the machine, removing all traces of grass and dirt.

Great care must be taken when washing with high pressure hoses, do not hold the water jet close to the paint work. Use steam cleaners with caution; be sure to remove all detergents to avoid any discolouring or damage to paint. Grease all grease points until fresh grease shows. Slacken rotor drive belts (where fitted). It is important where possible to store undercover to protect against rain and sunlight. Always ensure a firm level surface. Control levers must be wrapped in plastic sheeting and taped over to keep dry.



Warning

Regularly inspect the slew post and tank areas and remove any hedge trimmings which may have become lodged there. Failure to do this may cause damage to the machine's main lift ram.

Smear grease on all areas vulnerable to corrosion, in particular the chrome on the ram rods.

Remember: regular maintenance will greatly increase the life of the machine.

Spearhead 5 Series

Service and maintenance

Torque Settings

The Torque figures given below are recommended maximum settings only.

Size:	Tensile strength:	Description:	Torque setting: Nm:
M8	12.9	Pulley clamps	45
M10	8.8	General fasteners	65
M12	8.8	General fasteners	114
M12	12.9	Head bolts	170
M14	10.9	Flail bolts	200
M16	8.8	Head bracket bolts	280

Regular Service chart

Service Hours	Service points	Page	Grease	Drain	Check	Clean	Change
1 – 4 hrs	Bolts are fully tightened				X		
	Condition of flails	52			X		
	Condition of hoses especially for chafing	50			X		
	Flail bolts are fully tightened	52			X		
	Flail head retaining bolts are fully tightened				X		
	Gearbox seals (If oil is leaking replace immediately)				X		(X)
	Inspect leaks from fittings and pipes	50			X		
	Pins and bushes	53			X		
	Rotor bearing bolts are fully tightened				X		
8 hrs	Bearings	49	X				
	Gearbox & pump bolts are fully tightened				X		
	Gearbox oil level	49			X		
	Grease points & PTO shaft	49	X				
	Maintain correct belt tension on head (only with belt drive heads)	52			X		
	Oil level in reservoir	49			X		
	U.J. joints	49	X				
50 hrs	Gearbox oil (use EP 90 oil)	49		X			X
	Return line filter element	51					X
250-300 hrs	Mini filter	51					X
	Remove cable controlled spool	53	X				
	Motor drive	49	X				
	Return line filter element	51					X
	Hydraulic oil if any signs of contamination appears	51		X	X		

Spearhead 5 Series

Trouble shooting Excel / Highway

In the event of your machine not functioning correctly you will need to

Identify the type of failure

mechanical,

hydraulic

or

electrical.

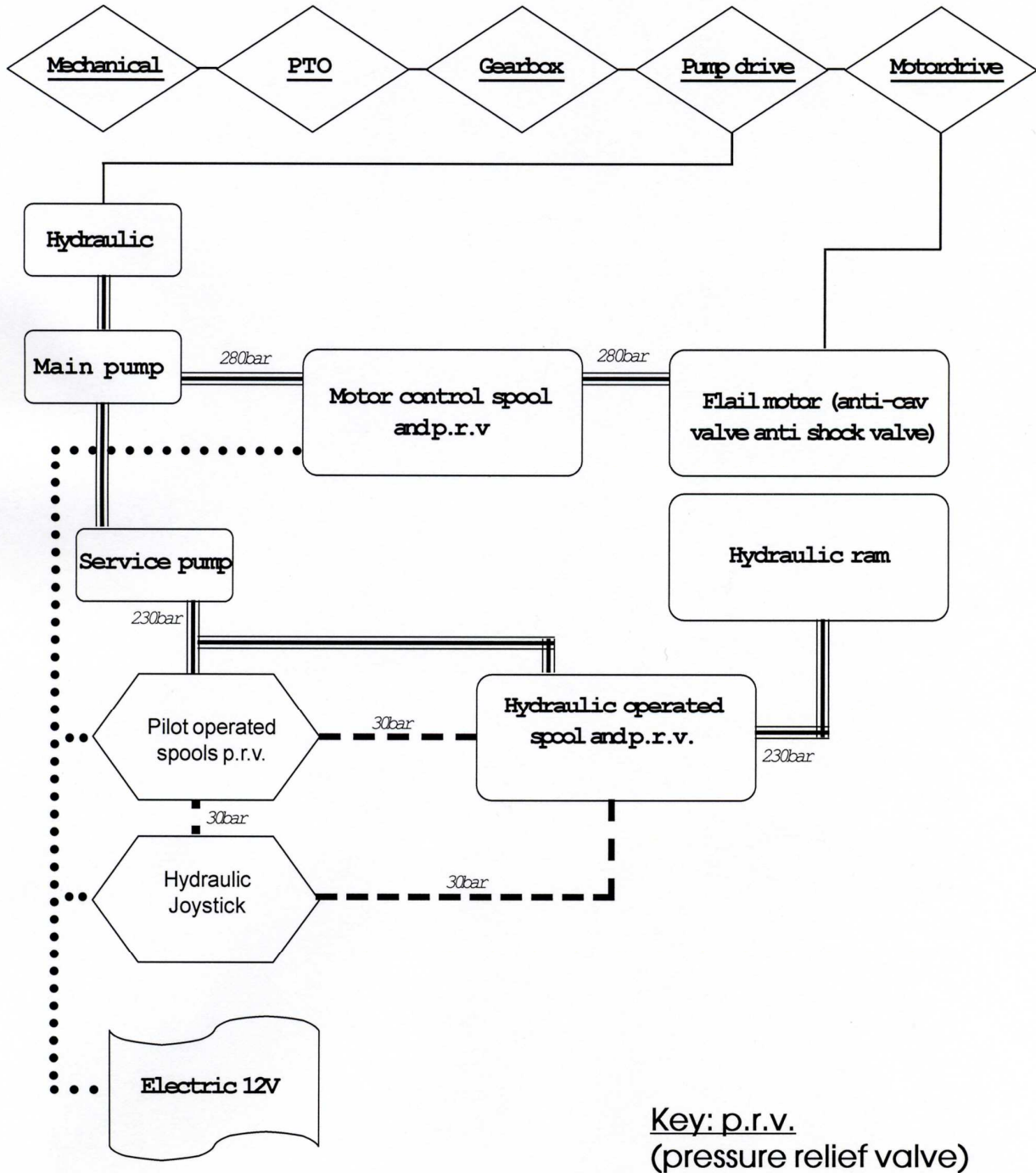

Spearhead 5 Series

Trouble shooting Excel / Highway

Problem	Cause	Solution
Gearbox overheating	Oil level incorrect	Check oil level
	Oil grade incorrect	Check oil grade
	Implement overloaded	Reduce forward speed
	Wrong PTO speed	Ensure tractor PTO speed matches implement
Excessive belt wear	Belt and pulley condition	Replace if necessary
	Pulley alignment	Check alignment
	Incorrect belt tension	Tension belts to spec.
	Overloading of implement	Reduce forward speed or increase height of cut
P.T.O. wear U.J. failure	Working angle too great	Reduce offset of implements
	Shaft incorrect length i.e. bottoming out	Resize PTO shaft as recommended
	Lack of maintenance	Grease PTO shaft as recommended
Cut Quality	Flails worn	Replace worn flails
	Rotor speed/direction	Check tractor PTO speed
	Crop condition	Look for suitable conditions
Rotor bearing failure	Rotor out of balance	See rotor vibration
	Wire/string in bearing	Remove wire/string
	Lack of maintenance	Grease bearings to schedule
	Water in bearing	Expel water with grease
Rotor vibration	Flails broken or missing	Replace flails
	Bearings worn or damaged	Replace bearings
	Rotor bend	Re-balance/replace rotor
	Build up of debris	Remove debris
	Incorrect speed	Check rotor R.P.M.
Oil tank overheating	Oil level incorrect	Fill tank to correct level
	Oil grade incorrect	Drain and refill tank with correct grade oil
	PTO speed too fast	Ensure the tractor's PTO speed matches implement
	Ambient temperature too high	Reduce work rate / install oil cooler
	Machine overloaded	Reduce forward speed or increase height of cut

Spearhead 5 Series

Trouble shooting Excel / Highway

Problem	Cause	Solution
Break-back operating Frequently	Machine overloaded	Reduce forward speed or increase height of cut
	Machine being used on excessive incline	Switch off auto reset
	Weight of machine being carried upon rear roller	Use Autopilot or head float
	Machine not set vertical	Shorten top link
Electrical switches not responding	Faulty supply from tractor	Check supply from your tractor fuse and connections
	Switch exposed to water	Store your machine under cover
Hydraulics not responding	Oil level low	Fill oil to correct level
	Oil pump suction filter blocked	Replace filter element
	Oil leak in pressure line	Check machine of leaks
	Drive line broken	Check pump is rotating
Joystick control sluggish	Air in pilot lines from joystick	Slacken off each line of pilot circuit individually at spool valve whilst operating. When all air is expelled retighten the line
Irregular arm movement	Spool contacting with housing	Check spool is free moving
	Broken spring in spool valve	Check spring
	Fail ram seals	Repair ram
Electrically operated valve not responding	Faulty wiring	Check wiring and switches
	Dirt in valve	Check of ingress of dirt
	Sticking valve	Replace the valve
	Insufficient voltage	Attend to bad connection

Spearhead 5 Series

Pump and Motor Failure

There are many reasons for pump and motor failure, cavitations (suction of air), peak pressure, contamination. These can be avoided by the following:

- Never run out of oil
- Never run a cold machine straight up to speed, ensure the engine idle speed before engage/disengage the head motor.
- Never increase or decrease engine speed quickly
- Regularly check that suction hose and pump fittings are tight.
- Never stop or start the rotor at 540r.p.m.
- Never cause sudden movements to the arms via your controls or bumps in the ground as pressure spikes will be transmitted back to the pump, resulting in failure.
- Avoid striking the rotor on obstacles i.e., road gullies as this causes pressure spikes.
- Never transport the machine with the PTO in gear.
- Never select 1000 speed gear for economy, start up speed is too high.
- Never operate above recommended PTO speed 540r.p.m. and risk over heating.

Remember: pump and motor warranty is limited to replacement due to faulty materials or manufacture. Cavitations, contamination and peak pressures are easily detected on inspection, warranty will not be considered if failure is due to misuse.

Spearhead 5 Series

Hydraulic Diagram – Excel 504, 565, 605

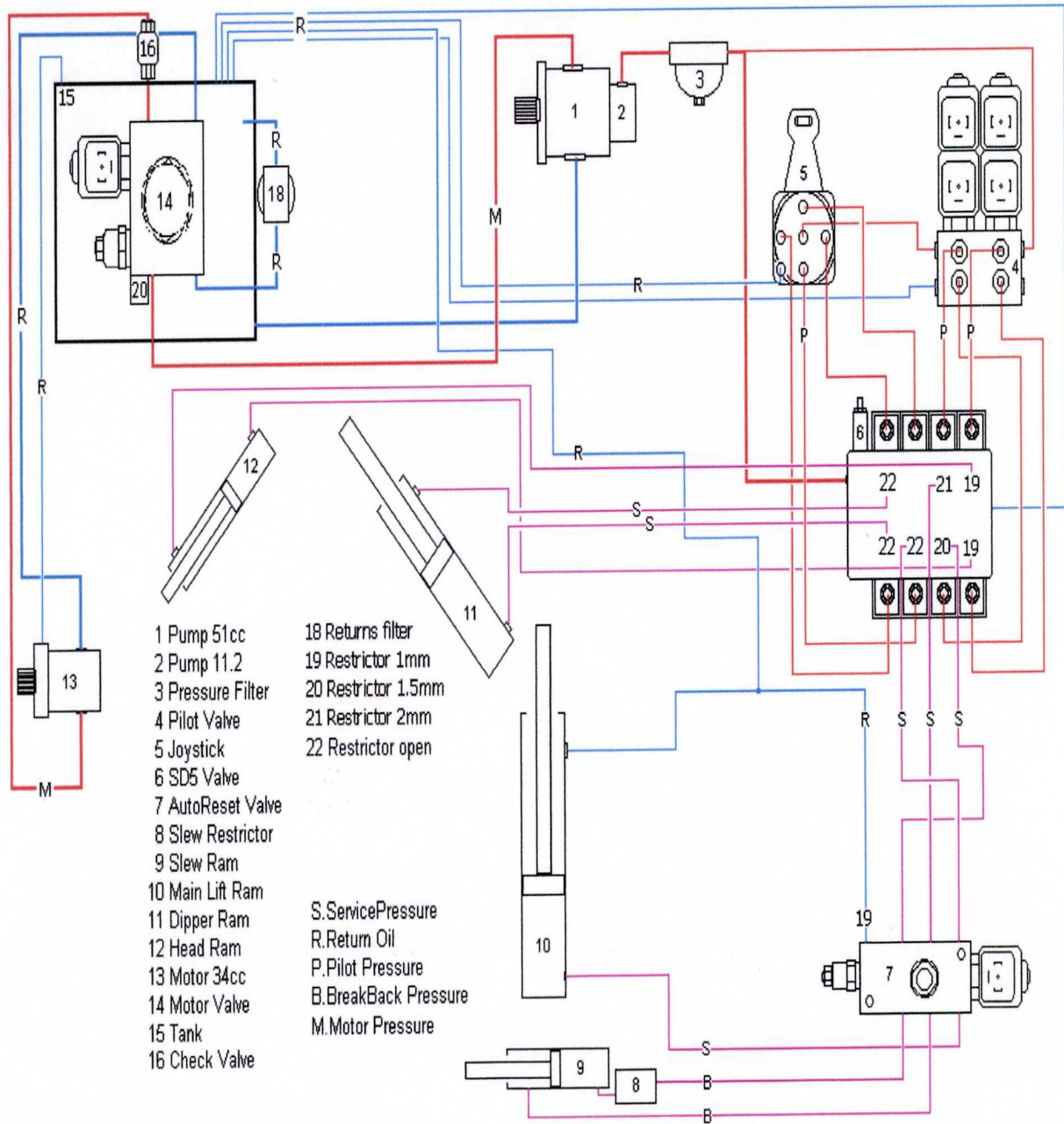

Hydraulic Diagram - Excel 504,565,605 - Elec Slew,Elec Rotor,AutoReset

2007 - Highway

Spearhead 5 Series

Hydraulic Diagram – Highway 504, 565, 605, Auto pilot

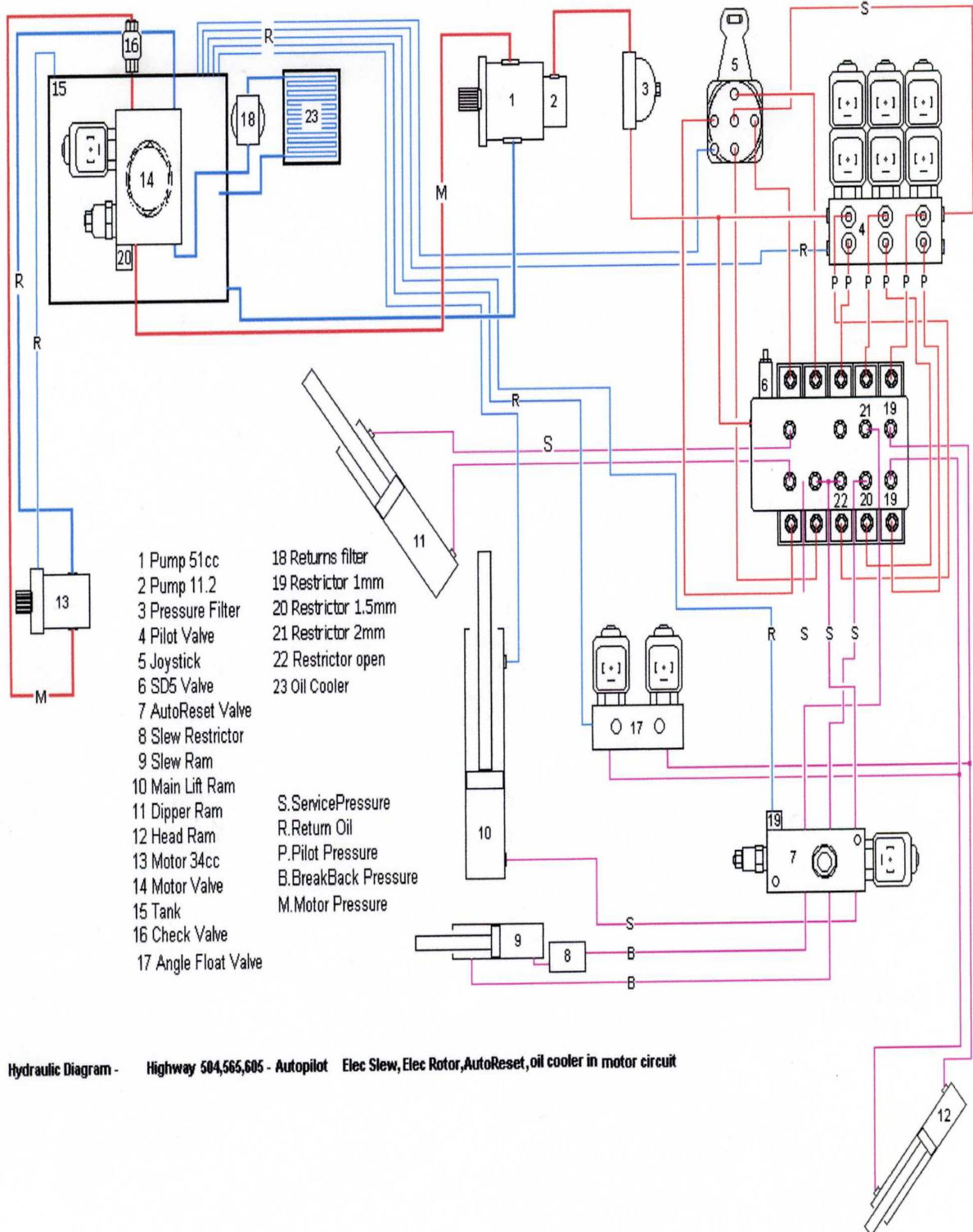

Hydraulic Diagram - Highway 504,565,605 - Autopilot Elec Slew, Elec Rotor, AutoReset, oil cooler in motor circuit

2007 - Cable

Spearhead 5 Series

Hydraulic Diagram – Cable Control

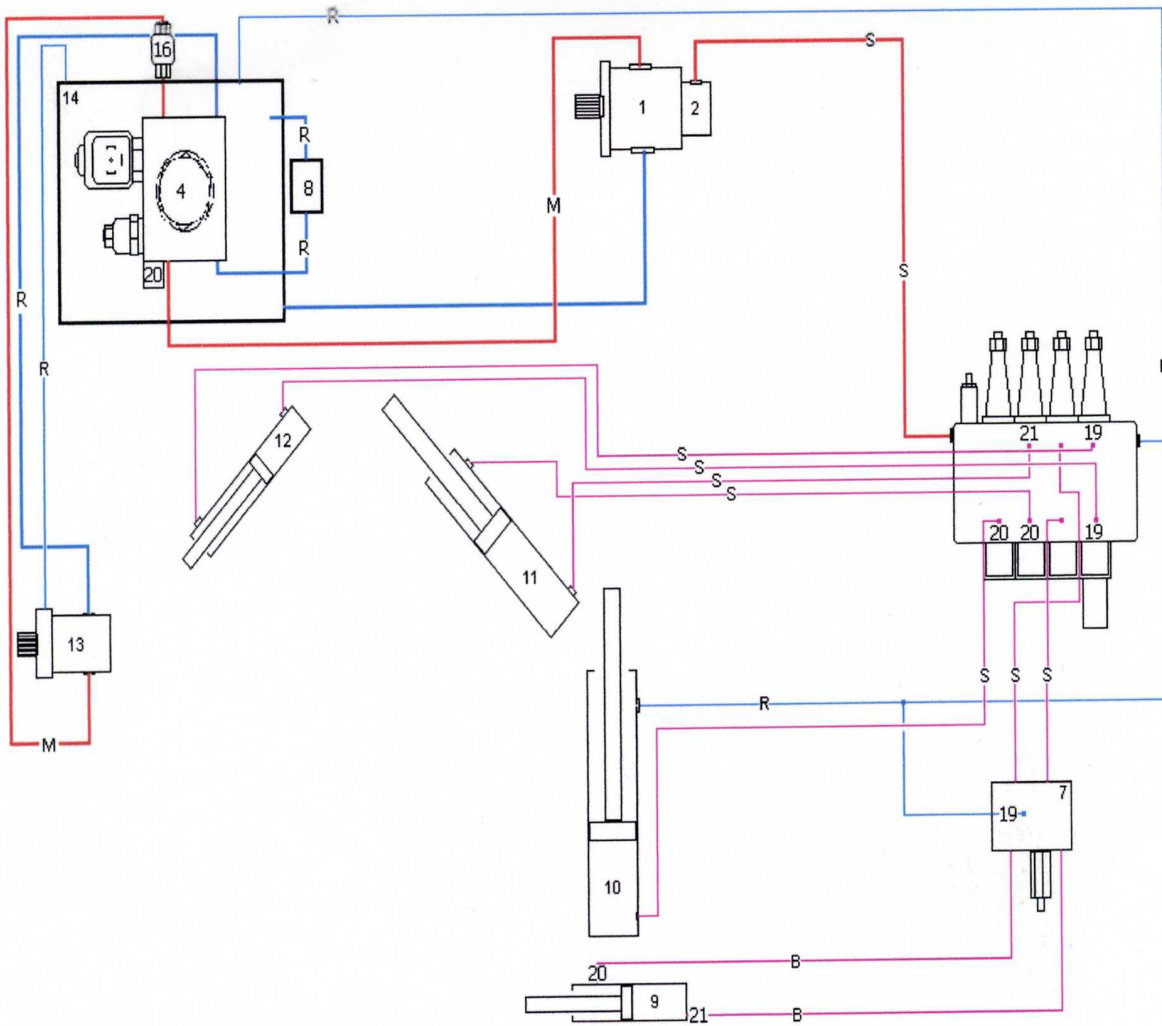

Hydraulic Diagram - Excel 504/565/605 - Cable Control 2/1/2007

- | | |
|--------------------|---------------------|
| 1.Pump 51cc | 19 Restrictor 1mm |
| 2.Pump 11.2 | 20 Restrictor 1.5mm |
| 3. | 21 Restrictor 2mm |
| 4.Motor Valve | |
| 5. | S.ServicePressure |
| 6.SD5 Valve | R.Return Oil |
| 7.Break Back Valve | B.BreakBack |
| 8.Returns filter | Pressure |
| 9.Slew Ram | M.Motor Pressure |
| 10.Main Lift Ram | |
| 11.Dipper Ram | |
| 12.Head Ram | |
| 13.Motor 34cc | |
| 14.Tank | |
| 15.Oil cooler | |

Spearhead 5 Series

Electric Diagram

- B - Black
- W - White
- T - Turquoise
- S - Slate
- R - Red
- O - Orange
- U - Blue
- N - Brown
- K - Pink
- Y - Yellow
- G - Green
- P - Purple

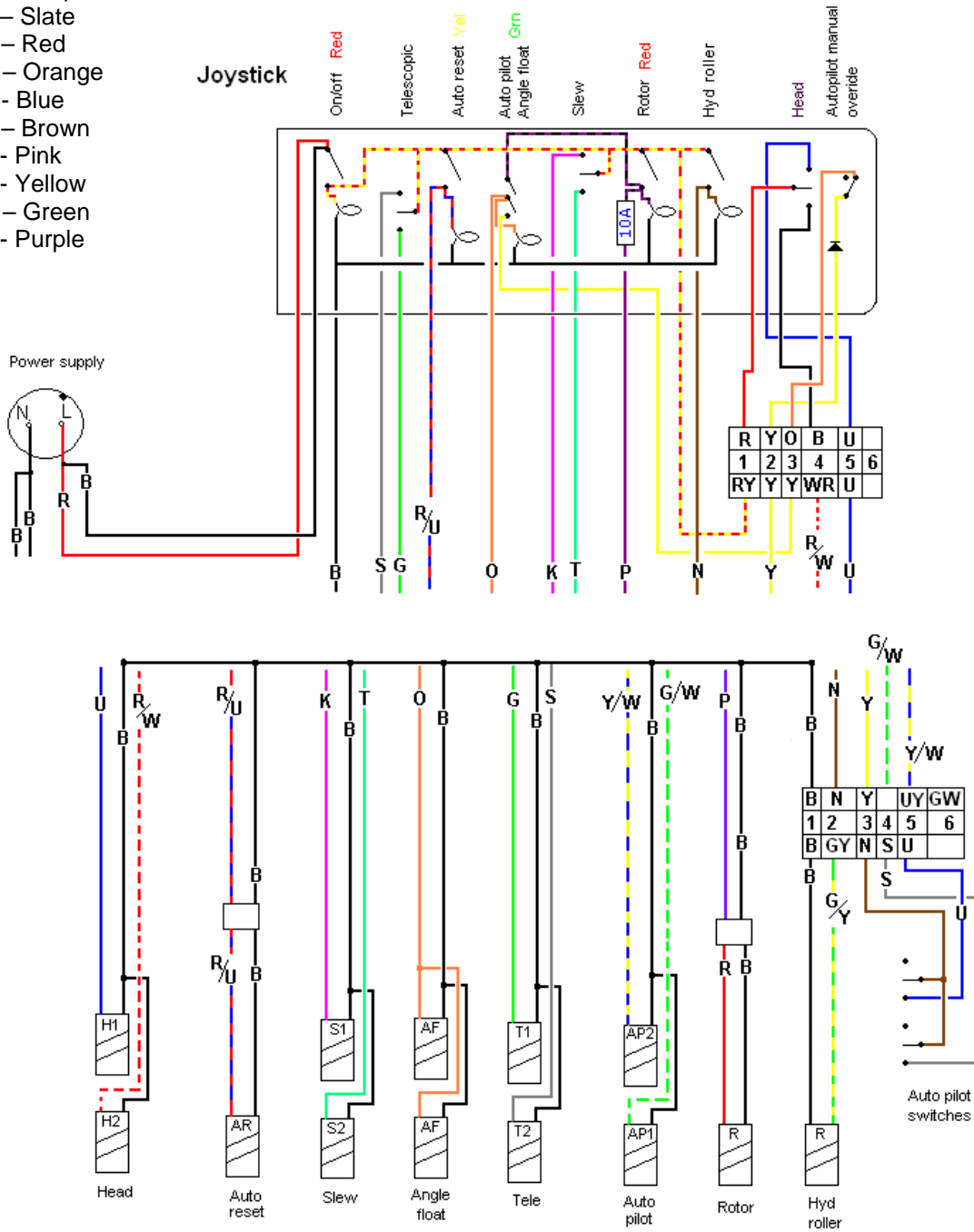

Spearhead 5 Series

The Spearhead Warranty

Spearhead warrants that the Spearhead machine referred to in the Warranty Registration Form will be free from defects in materials and workmanship for a period of 12 months from the date of sale. This warranty does not affect your statutory rights, but merely adds to them. Should you have a problem within 12 months from the date of sale please contact your original Spearhead dealer, or Spearhead's Service Department. Any part found to be defective during this period will be replaced or repaired, at Spearhead's discretion, by the dealer or a Spearhead Service Engineer.

Spearhead Warranty Conditions

1. The Warranty Registration Form must be completed and returned to Spearhead within 30 days of the date of sale.
2. This warranty does not cover defects arising from fair wear and tear, wilful damage, negligence, misuse, abnormal working conditions, use in competition, failure to follow Spearhead's instructions (oral or written, including all instructions and recommendation made in the Operator's Manual) or alteration or repair of the machinery without Spearhead's approval.
3. The machinery must have been serviced in accordance with the Operator's Manual and the Service Log must have been kept up to date and made available to the dealer should service, repair or warranty work be undertaken
4. This warranty does not cover claims in respect of wearing parts such as blades, flails, paintwork, tyres, belts, hydraulic hoses, bearings, bushes, linkage pins, top links, ball ends unless there is a manufacturing or material defect or the cost of normal servicing items such as oils and lubricants.
5. This warranty does not cover any expenses or losses incurred whilst the machinery is out of use for warranty repairs or parts replacement.
6. This warranty does not extend to parts, materials or equipment not manufactured by Spearhead, for which the Buyer shall only be entitled to the benefit of any such warranty or guarantee given by the manufacturer to Spearhead. Only genuine Spearhead replacement parts will be allowable for warranty claims.
7. All parts replaced by Spearhead under warranty become the property of Spearhead and must be returned to Spearhead if Spearhead so request. Such parts may only be disposed of after a warranty claim has been accepted and processed by Spearhead.
8. Spearhead is not liable under this warranty for any repairs carried out without Spearhead's written consent or without Spearhead being afforded a reasonable opportunity to inspect the machinery the subject of the warranty claim. Spearhead's written consent must, therefore, be obtained before any repairs are carried out or parts replaced. Use of non-Spearhead parts automatically invalidates the.

Spearhead Warranty. Failed components must not be dismantled except as specifically authorised by Spearhead and dismantling of any components without authorisation from Spearhead will invalidate this warranty.

9. All warranty claims must be submitted to Spearhead on Spearhead Warranty Claim Forms within 30 days of completion of warranty work.

Using the machine implies the knowledge and acceptance of these instructions and the limitations contained in this Manual.

Spearhead 5 Series

Extended Warranty (UK Only)

As an extension to the 12-month warranty set out above, Spearhead will provide an additional 12-month warranty cover subject to the Spearhead Warranty Conditions above and the Extended Warranty Conditions below.

Extended Warranty Conditions

1. The extended warranty applies to hydraulic pumps, motors, valves and gearboxes only. It does not apply to other parts, to consumables such as lubricants, seals or filters or to labour charges.
2. The machinery must have had an annual service carried out by an Authorised Spearhead Dealer or a Spearhead Service Engineer within 1 month of the first anniversary of the date of sale and the Service Report form must have been completed and stamped by the servicing dealer or Spearhead Service Engineer and sent to Spearhead within 14 days after the first annual service.
3. The extended warranty does not cover costs of transportation of the machinery to or from the dealer or Spearhead or the call out costs or travelling expenses of on-site visits.

Transfer of Warranty

The Spearhead warranty may be transferred to a subsequent owner of the machinery (for use within the UK) for the balance of the warranty period, subject to all of the warranty conditions and provided that the Change of Owner form is completed and sent to Spearhead within 14 days of change of ownership.

Spearhead reserves the right to make alterations and improvements to any machinery without notification and without obligation to do so.

Spearhead Machinery Ltd
Green View
Salford Priors
Evesham
Worcestershire
WR11 8SW
Tel: 01789 491860
Fax: 01789 778683
www.spearheadmachinery.com
enquiries@spearheadmachinery.com